



# NEXT EVO X

GAS INSTANTANEOUS WATER HEATER

**HOT WATER | HEATING | RENEWABLES**

[ariston.com/uk](http://ariston.com/uk)

# NEXT EVO X FEATURES AND BENEFITS



**Next Evo X is the new gas instantaneous water heater featuring a premium Italian design and LED display with easy user interface.**

- / Oxygen free copper heat exchanger
- / Built-in temperature stabilisation
- / Ultra compact – from 165mm in depth
- / Low NOx emissions with lean-rich burner
- / Energy-saving ECO function
- / Post ventilation system & overheat sensor for safety
- / Available in 11L LPG & 16L Natural Gas models
- / Low minimum water pressure at 0.2 bar
- / Low minimum working flow rate at 2.5l/min
- / Conversion kits available for both models
- / Rear spacer supplied with the product for horizontal flueing



FLAT

ENERGY EFFICIENT

LED DISPLAY

ELECTRONIC TEMPERATURE MANAGEMENT



## POWERFUL, COMPACT AND LIGHTWEIGHT HOT WATER ON DEMAND

The Next Evo X gas instantaneous water heater is perfect for retrofitting in applications which have a high demand for hot water. With its sleek, user-friendly design, compact size and innovative functions, the unit is extremely efficient and simple to use.

Plus, an intuitive LED display allows for easy temperature adjustment, as well as varying the flow of water required.

# NEXT EVO X GAS INSTANTANEOUS WATER HEATER

FRONTAL ACCESSABILITY

ITALIAN DESIGN

ULTRA COMPACT

ELECTRONIC IGNITION

LED DISPLAY

ENERGY EFFICIENT



- A. Icons**  
Shows whether in standard or high efficiency mode
- B. Temperature**  
Displays the set temperature of the unit on large LED display
- C. ECO Function**  
Reduces the maximum power to optimise emissions and fuel consumption
- D. Ignition**  
On/Off button to easily operate the unit

# PRODUCT DIMENSIONS

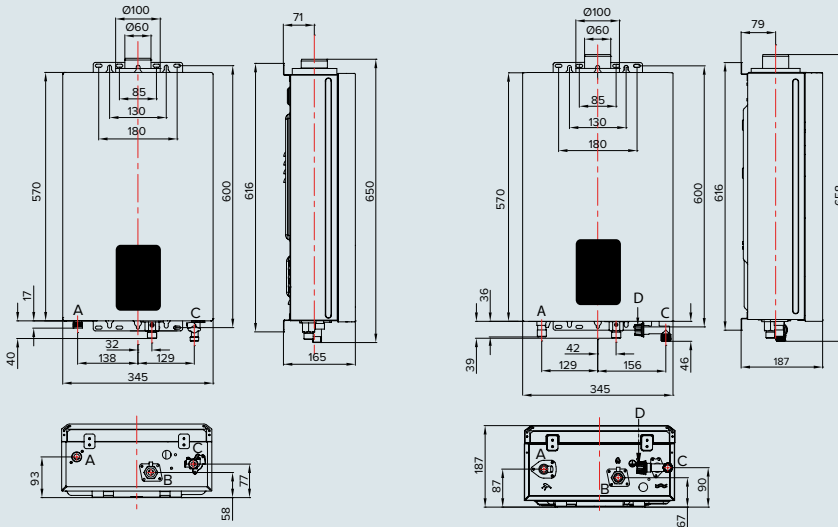

## NEXT EVO X

A	1/2" domestic hot water outlet
B	1/2" gas inlet
C	1/2" cold water inlet
D	Drain valve

## REAR SPACER INSTALLATION

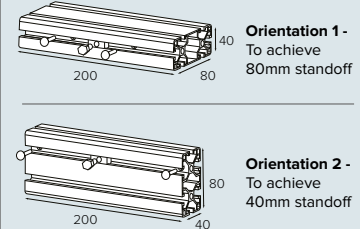

## NEXT EVO X

Capacity	11	16
ERP Energy Class	A	A
Load Profile	M	XL
Gas Type	LPG	NG
Weight (kg)	13	15
Maximum Nominal Heat Input (kW)	22	30
Minimum Nominal Heat Input (kW)	8.0	9.5
Minimum Working Pressure (bar)	0.2	0.2
Minimum Operating Flow Rate (l/min)	2.5	2.5
Nominal Flow Rate with $\Delta T@25^{\circ}\text{C}$ (l/min)	11	16
Power Supply Voltage/Frequency (V/Hz)	230/50	230/50
Nominal Noise Level (dB)	58	63
IPX Protection Level	IPX4	IPX4
Max Outlet Water Temperature ( $^{\circ}\text{C}$ )	65	65
Min Outlet Water Temperature ( $^{\circ}\text{C}$ )	35	35
Ambient Minimum Working Temperature ( $^{\circ}\text{C}$ )	5	5
Overall Dimensions HxWxD (mm)	570x345x165	570x345x187
PRODUCT CODE	3632535	3632533

## FLUES AND ACCESSORIES

Code	Description	Code	Description
3318000	Horizontal Flue Kit 60/100 (SE)	3318855	Vertical Flue with Black Terminal 60/100 (SE)
3319050	Vertical Starter with Horizontal Terminal Kit 60/100 (SE)	3632495	Conversion Kit from LPG to NG (For 11 Model)
3318003	90° Coaxial Elbow (SE)	3632498	Conversion Kit from NG to LPG (For 16 Model)
3318004	45° Coaxial Elbow (Pack of 2) (SE)	3318009	Black Lead Flashing Base Cap 18-44°
3318005	Coaxial Extension - 1000mm (SE)	3318011	Black Vent Cap Base for Flat Roof
3318006	Coaxial Extension - 500mm (SE)	3318015	Wall Bracket Kit (80 - 125mm) (Pack of 3)
3318007	Coaxial Extension - 250mm (SE)	3024085	Thermostatic Mixing Valve 3/4" 35-60°C
3318008	Vertical Starter (SE)		

## HOT WATER | HEATING | RENEWABLES

Customer Service: [customer.service.uk@aristonthermo.com](mailto:customer.service.uk@aristonthermo.com) | 0333 240 8777

Sales: [salesoffice@aristonthermo.com](mailto:salesoffice@aristonthermo.com) | 0333 240 6666

[ariston.com/uk](http://ariston.com/uk)

[@AristonUK](https://www.instagram.com/AristonUK)
[/AristonUK](https://www.facebook.com/AristonUK)
[/AristonThermo](https://www.youtube.com/AristonThermo)
[/AristonUK](https://www.linkedin.com/company/AristonUK)

