

November 2025

Baxi residential solutions

Your complete guide



BAXI

Baxi's got you.

We deliver customised heating and hot water solutions, uniting technologies from across our comprehensive range, to make things easier for you.

Here at Baxi, we've been at the forefront of heating and hot water innovation since 1866, and are now home to a wide portfolio of trusted and established brands – creating seamless, integrated heating and hot water solutions for homes nationwide.



Comprehensive and flexible solutions

We know that every residential installation is different, and one size never fits all – particularly when it comes to tackling the net-zero challenge. That's why we go way beyond just boilers, offering a complete range of solutions, for homes of all kinds:



Boilers – reliable, efficient and easy-to-install models, with flexible outputs to suit any home.



Cylinders – streamlined, robust and delivering rapid flow rates and recovery times across multiple outlets.



Air source heat pumps – ultra-efficient, future-ready, and available with dedicated cylinders and accessories.



Complementary products – flexible flues, convenient heating controls and efficiency boosting accessories.



All supported by industry-leading technical advice and hands-on installer training.

Boilers

Whether Natural Gas, LPG or Electric; Combi, System or Heat-only, we have a range, model and output suitable for all residential heating installations.

Our comprehensive boiler range offers complete reliability, efficiency and cost-effectiveness for any application – whether you're installing a brand-new heating system in a small apartment, or upgrading an existing system in a large multi-bathroom home. We also have a wide range of accessories that make our boilers more efficient and easier to maintain.



In this section

• Baxi 400 Combi 2.1	06
• Baxi 600 Combi 2	08
• Baxi 800 Combi 2	10
• Baxi 600 System 2	12
• Baxi 800 System 2	14
• Baxi 400 Heat	16
• Baxi 600 Heat	18
• Baxi 800 Heat	20
• Gas boilers specification matrix	22
• Amptec S	24
• Amptec	25
• Electromax	26



Did you know?

All Baxi residential gas boilers are rated 'A' for efficiency – and are easy to install, service and maintain.



Gas boilers

Baxi 400 Combi 2.1

The Baxi 400 Combi 2.1 is lightweight, small enough to fit into a 290mm deep cupboard and contains robust components including brass hydraulics and a stainless steel heat exchanger.



Outputs of 24, 30 and 36kW



Natural Gas or LPG manual conversion



Brass hydraulics



External analogue pressure gauge

Technical information	424 Combi 2.1	430 Combi 2.1	436 Combi 2.1
Product code (boiler only)	7872835	7872836	7872837
Gas			
Natural Gas or LPG	Yes	Yes	Yes
Inlet supply pressure (natural gas) mbar (nominal)	20	20	20
Maximum Gas Rate (G20) Q _{max} (m ³ /hr)	2.61	3.26	3.9
Heat input CHkW (max) gross (Q _{nHs})	20.6	25.7	25.7
Heat input CHkW (min) gross (Q _{nHs})	4.9	6.0	7.4
Heat output CH (non-condensing) - kW (max) (P _n)	20	25	25
Heat output CH (non-condensing) - kW (min) (P _n)	4.8	5.8	7.2
Heat output CH (condensing) - kW (max) (P _{nc})	21.8	27.1	27.1
Heat output CH (condensing) - kW (min) (P _{nc})	5.2	6.3	7.6
Heat input domestic hot water (DHW) - kW (max) gross (Q _{nwHs})	27.4	30	36.9
Heat output domestic hot water (DHW) - kW (max)	24	30	36
Water heating efficiency class	A	A	A
Central heating efficiency class (with addition of Baxi Usense 2 fitted)	A+	A+	A+
Electrical			
Permanent live required	Yes	Yes	Yes
External fuse rating (on connection board) (amps)	F0.5A L250VP	F0.5A L250VP	F0.5A L250VP
Pump overrun	Yes	Yes	Yes
Integral 'boiler only' frost thermostat	Yes	Yes	Yes
Hydraulic			
Maximum DHW flow rate (Delta T @ 35°C rise) (l/min)	10.2	12.2	15
Minimum DHW flow rate required (l/min)	2	2	2
Minimum operating DHW pressure required (bar)	0.5	0.5	0.5
Integral expansion vessel (litres)	7	7	7
Maximum capacity of CH system (litres)	100	100	100
Integral automatic bypass	Yes	Yes	Yes
Weights			
Installer lift weight (boiler) (kg)	28	29	30

What's in the box:

Baxi 400 Combi 2.1 boiler







Wall hanging bracket



Temporary Rigid Filling Link



Copper pipe tails

-  CH 22mm
-  Cold water inlet / DHW outlet 15mm
-  Gas 22mm
-  Condensate adapter
-  Safety discharge 15mm

Literature and fittings pack



What's inside:

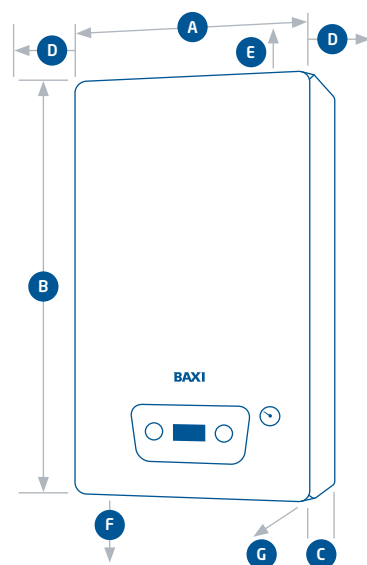
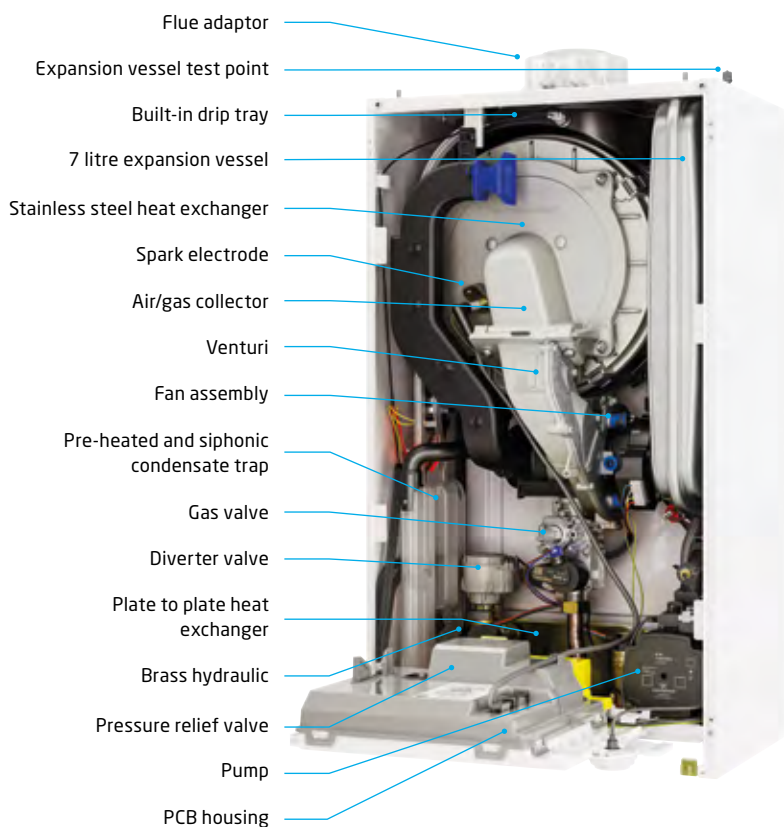

Dimensions:

Product dimensions	mm
A Width	395
B Height	700
C Depth	285
Service clearances	
D Side	2.5'
E Upper	178'
F Lower	150'
G Front - for operation	5'
Front - for servicing	450'
Wall to flue centre (not shown on diagram)	150mm

* These are minimum recommended dimensions, greater clearance will aid installation and maintenance

Compatible with:



Baxi Easy-Flue
See page 69



Multifit IFOS
See page 69



Baxi uSense 2
See page 66

SCAN ME



Gas boilers

Baxi 600 Combi 2

The Baxi 600 Combi 2 is small enough to fit into a 290mm deep cupboard, featuring built-in pipes behind facility within the boiler casing, brass hydraulics and a stainless steel heat exchanger.



Outputs of 24, 30 and 36kW



Natural Gas or LPG manual conversion



Brass hydraulics



External analogue pressure gauge

Technical information	624 Combi 2	630 Combi 2	636 Combi 2
Product code (boiler only)	7796586	7796587	7796588
Gas			
Natural Gas or LPG	Yes	Yes	Yes
Inlet supply pressure (natural gas) mbar (nominal)	20	20	20
Maximum Gas Rate (G20) Q _{max} (m ³ /hr)	2.61	3.26	3.9
Heat input CHkW (max) gross (Q _{nHs})	20.6	25.7	25.7
Heat input CHkW (min) gross (Q _{nHs})	4.9	6.0	7.4
Heat output CH (non-condensing) - kW (max) (P _n)	20	25	25
Heat output CH (non-condensing) - kW (min) (P _n)	4.8	5.8	7.2
Heat output CH (condensing) - kW (max) (P _{nc})	21.8	27.1	27.1
Heat output CH (condensing) - kW (min) (P _{nc})	5.2	6.3	7.6
Heat input domestic hot water (DHW) - kW (max) gross (Q _{nwHs})	27.4	30.9	36.9
Heat output domestic hot water (DHW) - kW (max)	24	30	36
Water heating efficiency class	A	A	A
Central heating efficiency class (with addition of Baxi Usense 2 fitted)	A+	A+	A+
Electrical			
Permanent live required	Yes	Yes	Yes
External fuse rating (on connection board) (amps)	F0.5A L250VP	F0.5A L250VP	F0.5A L250VP
Pump overrun	Yes	Yes	Yes
Integral 'boiler only' frost thermostat	Yes	Yes	Yes
Hydraulic			
Maximum DHW flow rate (Delta T @ 35°C rise) (l/min)	10.2	12.2	15
Minimum DHW flow rate required (l/min)	2	2	2
Minimum operating DHW pressure required (bar)	0.5	0.5	0.5
Integral expansion vessel (litres)	7	7	7
Maximum capacity of CH system (litres)	100	100	100
Integral automatic bypass	Yes	Yes	Yes
Weights			
Installer lift weight (boiler) (kg)	28	29	30

What's in the box:

Baxi 600 Combi 2 boiler







Wall hanging bracket



Easy-Fill permanent filling link



Copper pipe tails

-  CH 22mm
-  Cold water inlet / DHW outlet 15mm
-  Gas 22mm
-  Condensate adapter
-  Safety discharge 15mm

Literature and fittings pack



What's inside:

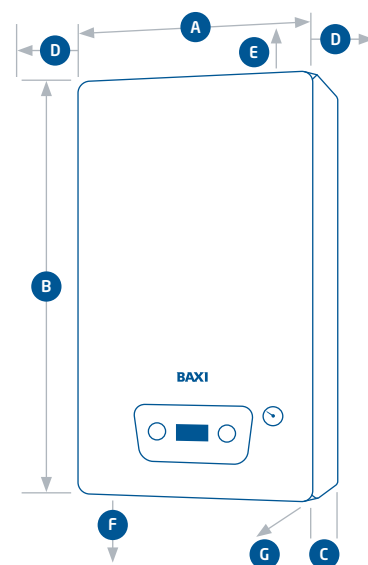
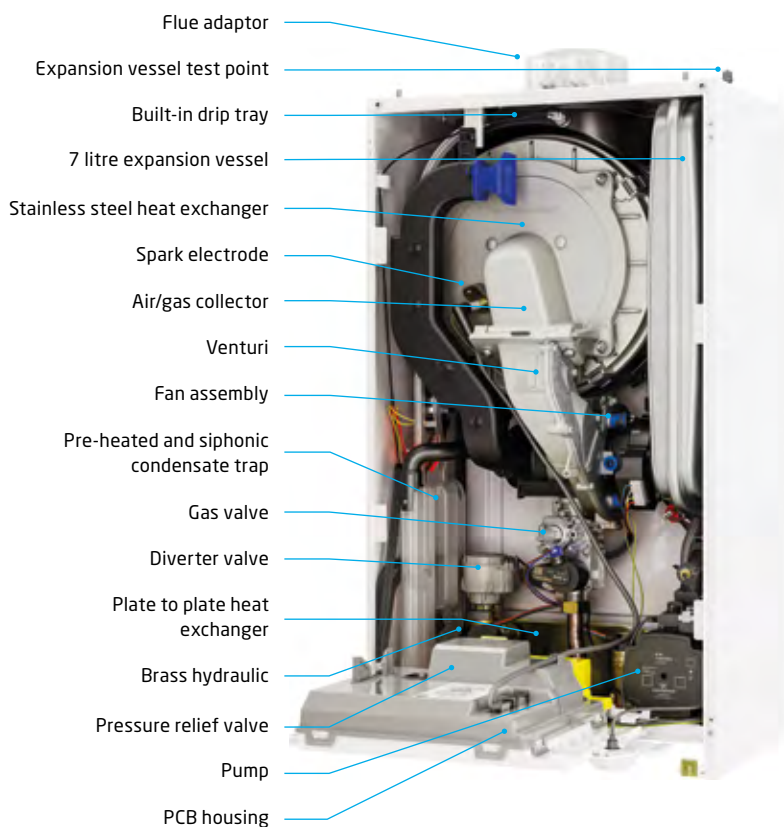

Dimensions:

Product dimensions	mm
A Width	395
B Height	700
C Depth	285
Service clearances	
D Side	2.5'
E Upper	178'
F Lower	150'
G Front - for operation	5'
Front - for servicing	450'
Wall to flue centre (not shown on diagram)	150mm

* These are minimum recommended dimensions, greater clearance will aid installation and maintenance

Compatible with:



Baxi Easy-Flue
See page 69



Multifit IFOS
See page 69



Baxi uSense 2
See page 66

SCAN ME



Gas boilers

Baxi 800 Combi 2

The Baxi 800 Combi 2 includes a compact Adey MagnaClean Micro2 system filter to protect the boiler. The boiler is lightweight and compact, with brass hydraulics and a stainless steel heat exchanger.



Outputs of 25, 30 and 36kW



Natural Gas or LPG manual conversion



Brass hydraulics



External analogue pressure gauge

Technical information	824 Combi 2	830 Combi 2	836 Combi 2
Product code (boiler only)	7814304	7814305	7814306
Gas			
Natural Gas or LPG	Yes	Yes	Yes
Inlet supply pressure (natural gas) mbar (nominal)	20	20	20
Maximum Gas Rate (G20) Q _{max} (m ³ /hr)	2.61	3.26	3.9
Heat input CHkW (max) gross (Q _{nHs})	20.6	25.7	25.7
Heat input CHkW (min) gross (Q _{nHs})	4.9	6	7.4
Heat output CH (non-condensing) - kW (max) (P _n)	20	25	25
Heat output CH (non-condensing) - kW (min) (P _n)	4.8	5.8	7.2
Heat output CH (condensing) - kW (max) (P _{nc})	21.8	27.1	27.1
Heat output CH (condensing) - kW (min) (P _{nc})	5.2	6.3	7.6
Heat input domestic hot water (DHW) - kW (max) gross (Q _{nWHs})	27.4	30.9	36.9
Heat output domestic hot water (DHW) - kW (max)	24	30	36
Water heating efficiency class	A	A	A
Central heating efficiency class (with addition of Baxi Usense 2 fitted)	A+	A+	A+
Electrical			
Permanent live required	Yes	Yes	Yes
External fuse rating (on connection board) (amps)	F0.5A L250VP	F0.5A L250VP	F0.5A L250VP
Pump overrun	Yes	Yes	Yes
Integral 'boiler only' frost thermostat	Yes	Yes	Yes
Hydraulic			
Maximum DHW flow rate (Delta T @ 35°C rise) (l/min)	10.2	12.2	15
Minimum DHW flow rate required (l/min)	2	2	2
Minimum operating DHW pressure required (bar)	0.5	0.5	0.5
Integral expansion vessel (litres)	7	7	7
Maximum capacity of CH system (litres)	100	100	100
Integral automatic bypass	Yes	Yes	Yes
Weights			
Installer lift weight (boiler) (kg)	28	29	30

What's in the box:

Baxi 800 Combi 2 boiler



Wall hanging bracket







Easy-Fill permanent filling link



Adey MagnaClean Micro 2 Filter



Copper pipe tails

-  CH 22mm
-  Cold water inlet / DHW outlet 15mm
-  Gas 22mm
-  Condensate adapter
-  Safety discharge 15mm

Literature and fittings pack



What's inside:

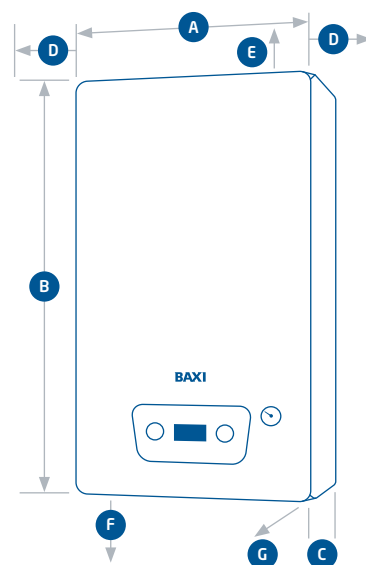
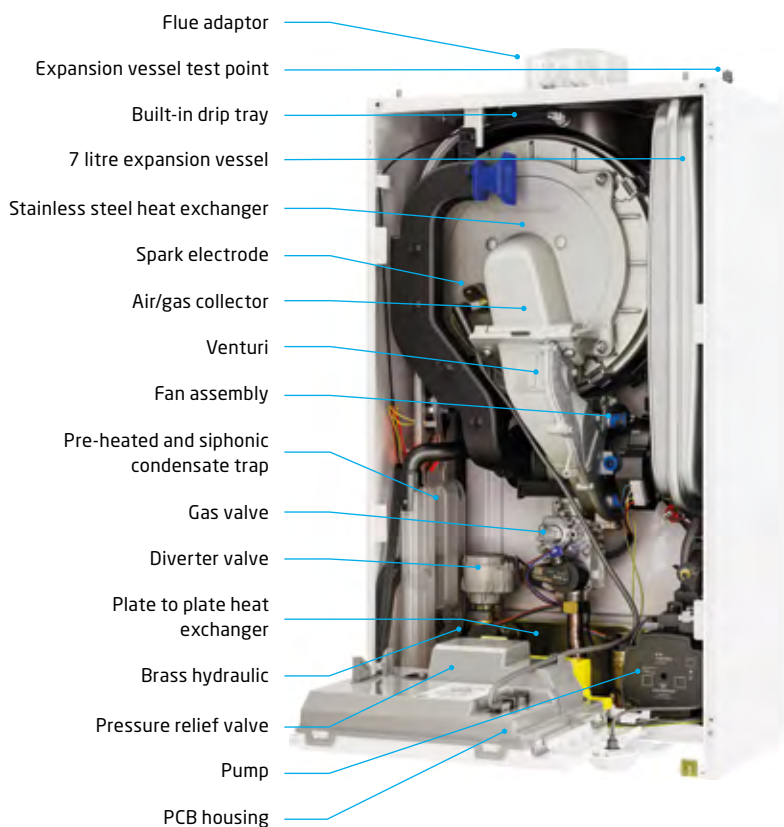

Dimensions:

Product dimensions	mm
A Width	395
B Height	700
C Depth	285
Service clearances	
D Side	2.5'
E Upper	178'
F Lower	150'
G Front - for operation	5'
Front - for servicing	450'
Wall to flue centre (not shown on diagram)	150mm

* These are minimum recommended dimensions, greater clearance will aid installation and maintenance

Compatible with:



Baxi Easy-Flue
See page 69



Multifit IFOS
See page 69



Baxi uSense 2
See page 66

SCAN ME



Gas boilers

Baxi 600 System 2

The Baxi 600 System 2 is lightweight and small enough to fit into a 290mm deep cupboard. The boiler has built-in pipes behind facility within the boiler casing, along with and a stainless steel heat exchanger.



Outputs of 15, 18 and 24kW



Natural Gas or LPG manual conversion



Brass hydraulics



External analogue pressure gauge

Technical information	615 System 2	618 System 2	624 System 2
Product code (boiler only)	7798687	7802020	7802241
Gas			
Natural Gas or LPG	Yes	Yes	Yes
Inlet supply pressure (natural gas) mbar (nominal)	20	20	20
Maximum Gas Rate (G20) Q _{max} (m ³ /hr)	1.64	1.97	2.61
Heat input CHkW (max) gross (Q _{nHs})	15.5	18.6	24.7
Heat input CHkW (min) gross (Q _{nHs})	4.9	4.9	4.9
Heat output CH (non-condensing) - kW (max) (P _n)	15	18	24
Heat output CH (non-condensing) - kW (min) (P _n)	4.8	4.8	4.8
Heat output CH (condensing) - kW (max) (P _{nc})	16.3	19.9	26.3
Heat output CH (condensing) - kW (min) (P _{nc})	5.2	5.2	5.2
Heat input domestic hot water (DHW) - kW (min) gross (Q _{nWHs})	n/a	n/a	n/a
Heat output domestic hot water (DHW) - kW (max)	n/a	n/a	n/a
Water heating efficiency class	A	A	A
Electrical			
Permanent live required	Yes	Yes	Yes
External fuse rating (on connection board) (amps)	F0.5A L250VP	F0.5A L250VP	F0.5A L250VP
Pump overrun	Yes	Yes	Yes
Integral 'boiler only' frost thermostat	Yes	Yes	Yes
Hydraulic			
Maximum DHW flow rate (Delta T @ 35°C rise) (l/min)	n/a	n/a	n/a
Minimum DHW flow rate required (l/min)	2	2	2
Minimum operating DHW pressure required (bar)	0.5	0.5	0.5
Integral expansion vessel (litres)	7	7	7
Maximum capacity of CH system (litres)	100	100	100
Integral automatic bypass	Yes	Yes	Yes
Weights			
Installer lift weight (boiler) (kg)	28	29	30

What's in the box:





Baxi 600 System 2 boiler



Wall hanging bracket



Copper pipe tails

-  CH 22mm
-  Gas 22mm
-  Condensate adapter
-  Safety discharge 15mm

Literature and fittings pack



What's inside:

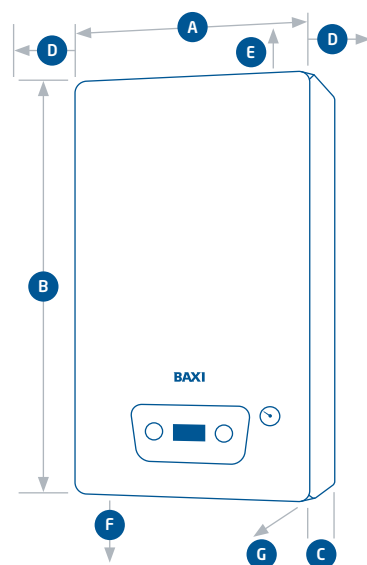
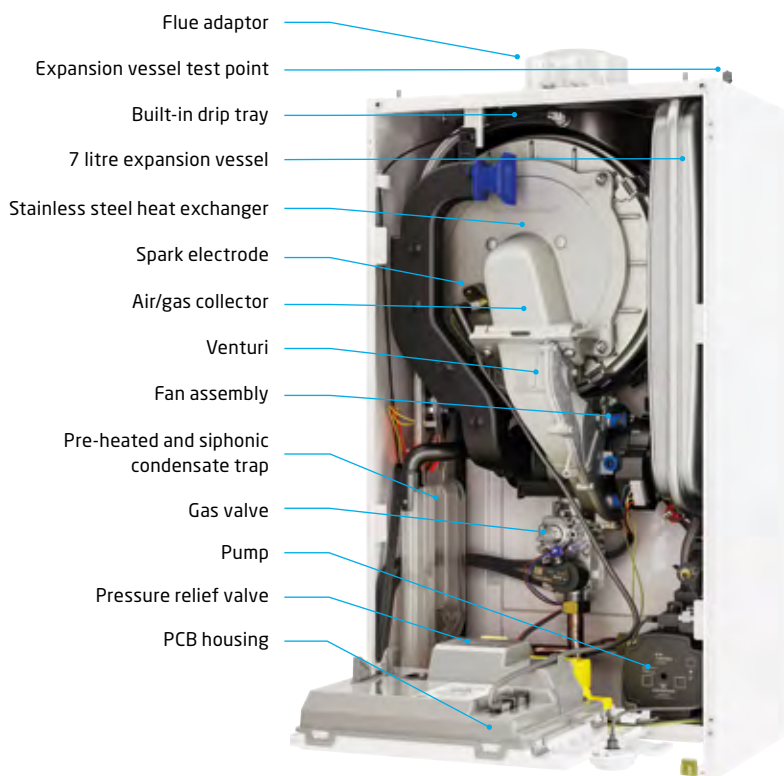

Dimensions:

Product dimensions	mm
A Width	395
B Height	700
C Depth	285
Service clearances	
D Side	2.5'
E Upper	178'
F Lower	150'
G Front - for operation Front - for servicing	5' 450'
Wall to flue centre (not shown on diagram)	150mm

* These are minimum recommended dimensions, greater clearance will aid installation and maintenance

Compatible with:



Baxi Easy-Flue
See page 69



Baxi RF Thermostat (Twin Channel)
See page 67



Baxi and Megaflo cylinders
See page 28

SCAN ME



Gas boilers

Baxi 800 System 2

The Baxi 800 System 2 includes a compact Adey MagnaClean Micro2 system filter to protect the boiler. The boiler is lightweight and has built-in pipes behind facility within the boiler casing, along with brass hydraulics and a stainless steel heat exchanger.



Outputs of 18, 24 and 30kW



Natural Gas or LPG manual conversion



Brass hydraulics



External analogue pressure gauge

Technical information	818 System 2	824 System 2	830 System 2
Product code (boiler only)	7814313	7814314	7814315
Gas			
Natural Gas or LPG	Yes	Yes	Yes
Inlet supply pressure (natural gas) mbar (nominal)	20	20	20
Maximum Gas Rate (G20) Q _{max} (m ³ /hr)	1.97	2.61	3.26
Heat input CHkW (max) gross (Q _{nHs})	18.6	24.7	30.9
Heat input CHkW (min) gross (Q _{nHs})	4.9	4.9	6
Heat output CH (non-condensing) - kW (max) (P _n)	18	24	30
Heat output CH (non-condensing) - kW (min) (P _n)	4.8	4.8	5.8
Heat output CH (condensing) - kW (max) (P _{nc})	19.9	26.3	32.4
Heat output CH (condensing) - kW (min) (P _{nc})	5.2	5.2	6.4
Heat input domestic hot water (DHW) - kW (max) gross (Q _{nwHs})	n/a	n/a	n/a
Heat output domestic hot water (DHW) - kW (max)	n/a	n/a	n/a
Water heating efficiency class	A	A	A
Electrical			
Permanent live required	Yes	Yes	Yes
External fuse rating (on connection board) (amps)	F0.5A L250VP	F0.5A L250VP	F0.5A L250VP
Pump overrun	Yes	Yes	Yes
Integral 'boiler only' frost thermostat	Yes	Yes	Yes
Hydraulic			
Maximum DHW flow rate (Delta T @ 35°C rise) (l/min)	n/a	n/a	n/a
Minimum DHW flow rate required (l/min)	2	2	2
Minimum operating DHW pressure required (bar)	0.5	0.5	0.5
Integral expansion vessel (litres)	7	7	7
Maximum capacity of CH system (litres)	100	100	100
Integral automatic bypass	Yes	Yes	Yes
Weights			
Installer lift weight (boiler) (kg)	29	30	30

What's in the box:

Baxi 800 System 2 boiler



Wall hanging bracket



Adey MagnaClean Micro 2 Filter



Copper pipe tails

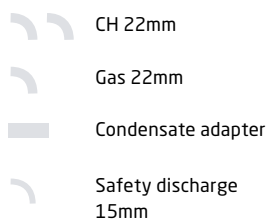

Literature and fittings pack



What's inside:

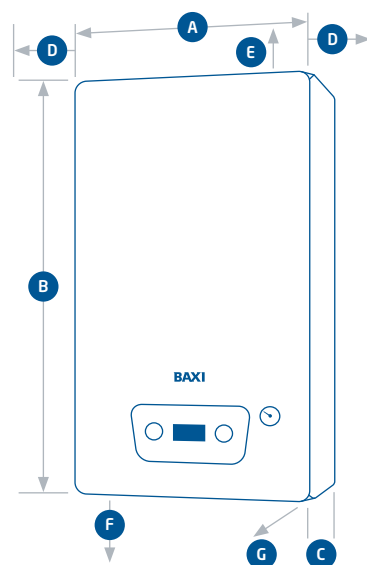
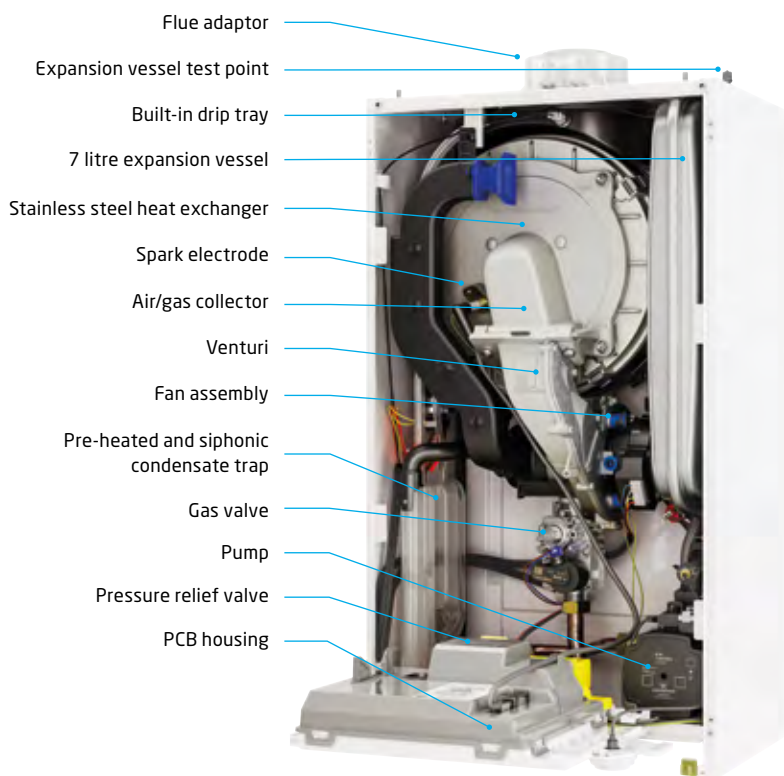

Dimensions:

Product dimensions	mm
A Width	395
B Height	700
C Depth	285
Service clearances	
D Side	2.5'
E Upper	178'
F Lower	150'
G Front - for operation	5'
Front - for servicing	450'
Wall to flue centre (not shown on diagram)	150mm

* These are minimum recommended dimensions, greater clearance will aid installation and maintenance

Compatible with:

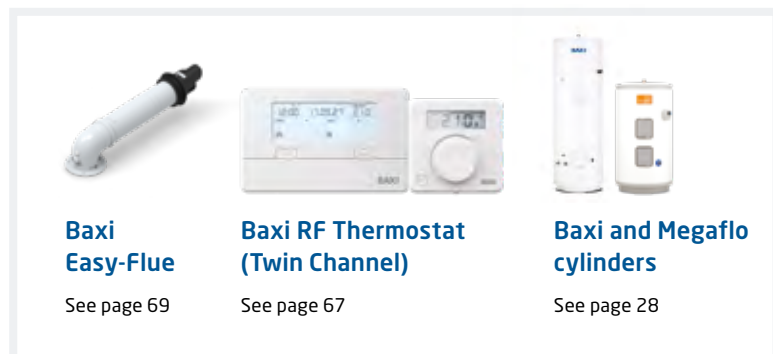

SCAN ME



Gas boilers

Baxi 400 Heat

The Baxi 400 Heat has no need for a pump overrun or permanent live and has a lift weight from just 17.4kg. This boiler can be installed on open vent or sealed systems and has an optional in-case rear flue for a neater installation.



Outputs of 15, 18, 24 & 30kW



Compact cupboard fit



No pump overrun or permanent live required

Technical information	415 Heat	418 Heat	424 Heat	430 Heat
Product code (boiler only)	7668933	7668934	7668935	7668936
Gas				
Natural Gas	Yes	Yes	Yes	Yes
Propane LPG	n/a	n/a	n/a	n/a
Inlet supply pressure - mbar (nominal)	20	20	20	20
Maximum gas rate (G20) - Qmax m ³ / hr	1.75	2.07	2.73	3.27
Heat input CH - kW (max) gross (QnHs)	18.32	21.75	28.62	34.35
Heat input CH - kW (min) gross (QnHs)	8.59	8.59	8.59	8.59
Heat output CH (non-condensing) - kW (max) (Pn)	16	19	25	30
Heat output CH (non-condensing) - kW (min) (Pn)	7.5	7.5	7.5	7.5
Electrical				
Permanent live required	No	No	No	No
External fuse rating (on connection board) (amps)	3	3	3	3
Pump overrun	No	No	No	No
Weights				
Installer lift weight (boiler) (kg)	17.4	17.4	17.4	19.5

Compatible with:



Baxi hot water cylinders

See pages 30-33



Megaflo hot water cylinders

See pages 34-47



Baxi RF Thermostat (Twin Channel)

See page 67

What's in the box:

Baxi 400 Heat boiler



Wall mounting bracket



Top flue adaptor



Power lead



Copper pipe tail



Literature and fittings pack



What's inside:

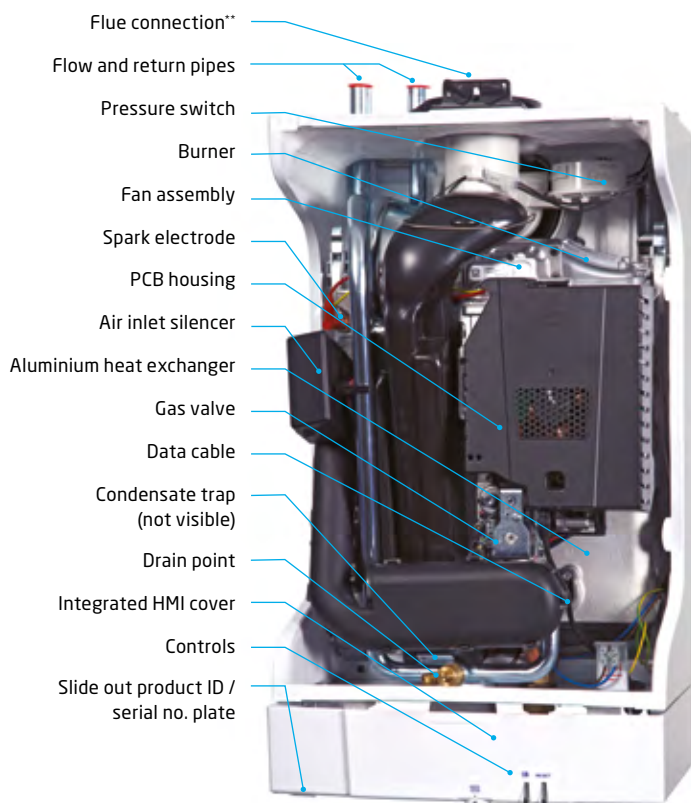

** To be replaced by flue connector if flueing from top

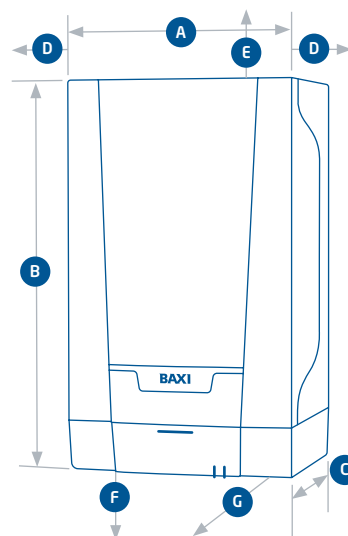

Dimensions:

Product dimensions	mm
A Width	370
B Height	625 (790mm if using flue elbow)
C Depth	270
Service clearances	
D Side	5*
E Upper	190* (35mm if using rear flue)
F Lower	120* (35mm in 300mm deep wall cupboard)
G Front - for operation	5*
Front - for servicing	500*

* These are minimum recommended dimensions, greater clearance will aid installation and maintenance

SCAN ME



Gas boilers

Baxi 600 Heat

The Baxi 600 Heat has no need for a pump overrun or permanent live and has a lift weight from just 17.4kg. This powerful boiler can be installed on open vent or sealed systems and has an optional in-case rear flue, making it the perfect choice for homes with a high demand for hot water.



Outputs of 16, 19 & 25kW



Compact cupboard fit



No pump overrun or permanent live required

Technical information	616 Heat	619 Heat	625 Heat
Product code (boiler only)	7711999	7712020	7712022
Gas			
Natural Gas	Yes	Yes	Yes
Propane LPG	n/a	n/a	n/a
Inlet supply pressure - mbar (nominal)	20	20	20
Maximum gas rate (G20) - Qmax m ³ / hr	1.75	2.07	2.73
Heat input CH - kW (max) gross (QnHs)	18.32	21.75	28.62
Heat input CH - kW (min) gross (QnHs)	8.59	8.59	8.59
Heat output CH (non-condensing) - kW (max) (Pn)	16	19	25
Heat output CH (non-condensing) - kW (min) (Pn)	7.5	7.5	7.5
Electrical			
Permanent live required	No	No	No
External fuse rating (on connection board) (amps)	3	3	3
Pump overrun	No	No	No
Weights			
Installer lift weight (boiler) (kg)	17.4	17.4	17.4

Compatible with:



Baxi hot water cylinders

See pages 30-33



Megaflo hot water cylinders

See pages 34-47



Baxi RF Thermostat (Twin Channel)

See page 67

What's in the box:

Baxi 600 Heat boiler



Wall mounting bracket



Top flue adaptor



Power lead



Copper pipe tail



Literature and fittings pack



What's inside:

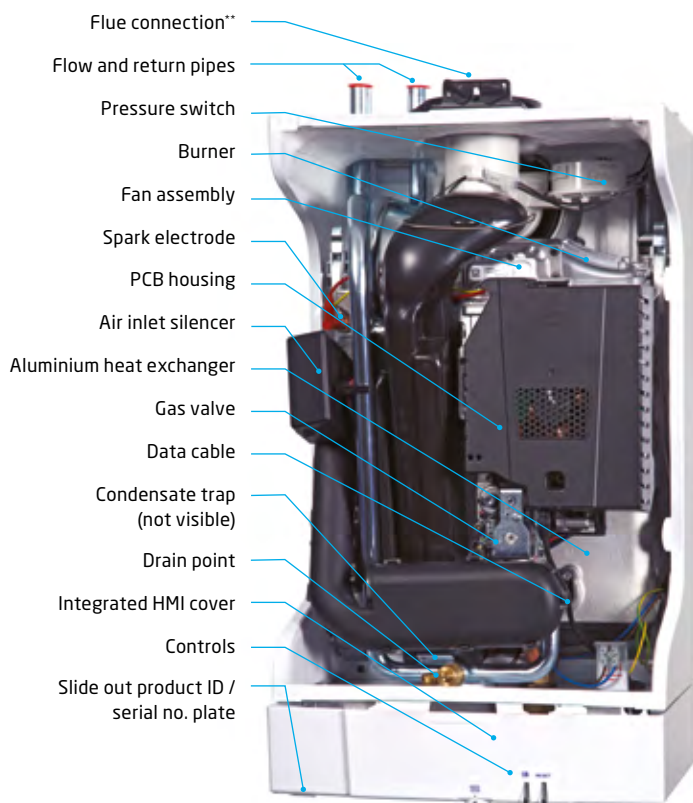

** To be replaced by flue connector if flueing from top

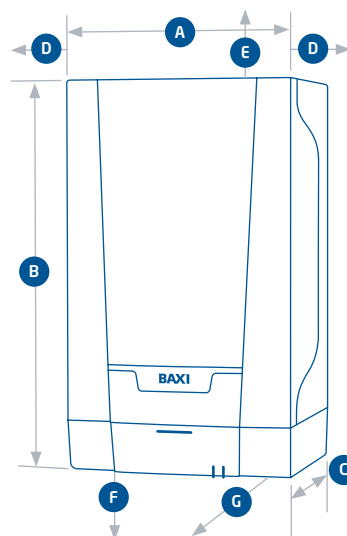

Dimensions:

Product dimensions	mm
A Width	370
B Height	625 (790mm if using flue elbow)
C Depth	270
Service clearances	
D Side	5*
E Upper	190* (35mm if using rear flue)
F Lower	120* (35mm in 300mm deep wall cupboard)
G Front - for operation	5*
Front - for servicing	500*

* These are minimum recommended dimensions, greater clearance will aid installation and maintenance

SCAN ME



Gas boilers

Baxi 800 Heat

The Baxi 800 Heat includes a compact Adey MagnaClean Micro2 system filter to protect the boiler. The boiler has no need for a pump overrun or permanent live and has a lift weight from just 17.4kg.



Outputs of 16, 19, 25 & 30kW



Compact cupboard fit



No pump overrun or permanent live required



Adey Micro 2 Filter included

Technical information	816 Heat	819 Heat	825 Heat	830 Heat
Product code (boiler only)	7749866	7898832	7749868	7749869
Gas				
Natural Gas	Yes	Yes	Yes	Yes
Propane LPG	n/a	n/a	n/a	n/a
Inlet supply pressure - mbar (nominal)	20	20	20	20
Maximum gas rate (G20) - Q _{max} m ³ / hr	1.75	2.07	2.73	3.27
Heat input CH - kW (max) gross (Q _{nHs})	18.32	21.75	28.62	34.35
Heat input CH - kW (min) gross (Q _{nHs})	8.59	8.59	8.59	8.59
Heat output CH (non-condensing) - kW (max) (P _n)	16	19	25	30
Heat output CH (non-condensing) - kW (min) (P _n)	7.5	7.5	7.5	7.5
Electrical				
Permanent live required	No	No	No	No
External fuse rating (on connection board) (amps)	3	3	3	3
Pump overrun	No	No	No	No
Weights				
Installer lift weight (boiler) (kg)	17.4	17.4	17.4	19.5

Compatible with:



Baxi hot water cylinders

See pages 30-33



Megaflo hot water cylinders

See pages 34-47



Baxi RF Thermostat (Twin Channel)

See page 67

What's in the box:

Baxi 800 Heat boiler



Adey MagnaClean Micro 2 Filter



Wall mounting bracket



Top flue adaptor



Power lead



Copper pipe tail

Gas 22mm



Literature and fittings pack



What's inside:

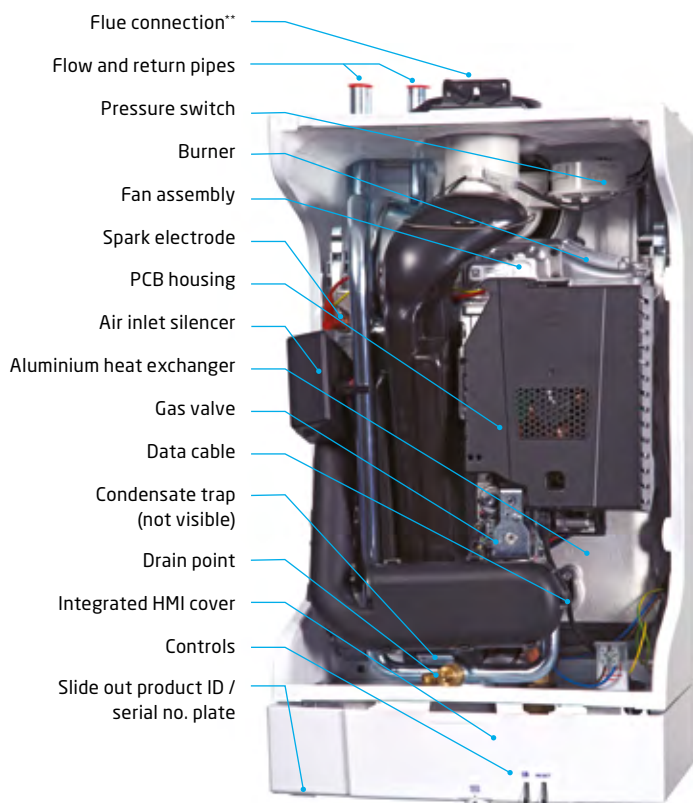

** To be replaced by flue connector if flueing from top

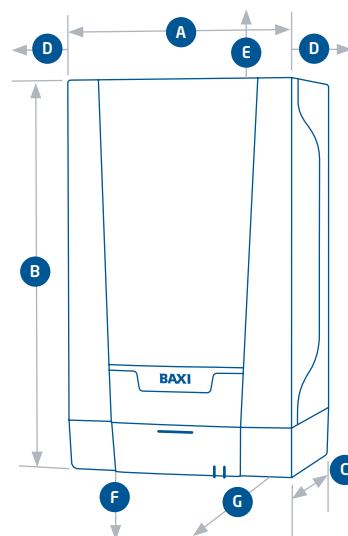

Dimensions:

Product dimensions	mm
A Width	370
B Height	625 (790mm if using flue elbow)
C Depth	270
Service clearances	
D Side	5*
E Upper	190* (35mm if using rear flue)
F Lower	120* (35mm in 300mm deep wall cupboard)
G Front - for operation	5*
Front - for servicing	500*

* These are minimum recommended dimensions, greater clearance will aid installation and maintenance

SCAN ME



Specification matrix



	Baxi 400 Combi 2.1	Baxi 400 Heat	Baxi 600 Combi 2	Baxi 600 System 2
Outputs (kW)	24, 30, 36	15, 18, 24 & 30	24, 30, 36	15, 18, 24
Flow rate (@35°C rise)	10.2, 12.2, 15	n/a	10.2, 12.2, 15	n/a
Installer lift weight (kg)	28 to 30	17.4 to 19.5	28 to 30	28 to 30
Heat exchanger	Stainless steel	Aluminium	Stainless steel	Stainless steel
Hydraulics	Brass	n/a	Brass	Brass
Cupboard fit	Yes (fits in a 290mm deep cupboard)	Yes (fits in a 290mm deep cupboard)	Yes (fits in a 290mm deep cupboard)	Yes (fits in a 290mm deep cupboard)
Filling device	Temporary rigid filling link	Optional flexible link	Easy-Fill permanent filling link	Optional flexible link
Flue position	Top central	Top central and in-case rear flue	Top central	Top central
Mounting	Hanging bracket	Hanging bracket	Hanging bracket	Hanging bracket
Expansion vessel size	7 litres	n/a	7 litres	7 litres
Boiler temperature controls	CH & DHW potentiometer	CH dial	CH & DHW potentiometer	CH potentiometer
uSense 2 compatible	Yes	No	Yes	No
Sound power levels (dBA)	50 - 51	39 - 49	50 - 51	47 - 52



Baxi 600 Heat	Baxi 800 Combi 2	Baxi 800 System 2	Baxi 800 Heat
16, 19, 25	24, 30, 36	18, 24, 30	16, 19, 25, 30
n/a	10.2, 12.2, 15	n/a	n/a
17.4 to 19.5	28 to 30	29 to 30	17.4 to 19.5
Aluminium	Stainless steel	Stainless steel	Aluminium
n/a	Brass	Brass	n/a
Yes (fits in a 290mm deep cupboard)	Yes (fits in a 290mm deep cupboard)	Yes (fits in a 290mm deep cupboard)	Yes (fits in a 290mm deep cupboard)
Optional flexible link	Easy-Fill permanent filling link	Optional flexible link	Optional flexible link
Top central and in-case rear flue	Top central	Top central	Top central and in-case rear flue
Hanging bracket	Hanging bracket	Hanging bracket	Hanging bracket
n/a	7 litres	7 litres	n/a
CH dial	CH & DHW potentiometer	CH potentiometer	CH dial
No	Yes	No	No
39 - 45	50 - 51	49 - 53	39 - 45

For more information visit www.baxi.co.uk/professional/products

SCAN ME



Electric boilers

Amptec S

Efficient electric system boiler suitable for both radiator and underfloor systems. Designed to reduce unnecessary external works with all key heating system components built within the unit and can be used in conjunction with a Solar PV battery to help the user with running costs.



4-18kW outputs



Digital and analogue pressure gauge



Uses right amount of fuel to meet the set central heating temperatures



Solar PV battery compatibility

Technical information	Amptec S4 single phase	Amptec S6 single phase	Amptec S8 single phase	Amptec S12 single phase	Amptec S14 three phase	Amptec S18 three phase
Product code	7828706	7828707	7828708	7828710	7828711	7828712
Maximum direct kW rating (kW)	4	6	8	12	14	18
Weight empty (kg)	20	20	21.5	21.5	22.5	22.5
Weight full (kg)	21	21	23	23	24.5	24.5
Volume (litres)	1	1	1.5	1.5	2	2
Pressure relief valve setting (bar)	2.8	2.8	2.8	2.8	2.8	2.8
Maximum heating pressure	2.8	2.8	2.8	2.8	2.8	2.8
Minimum heating pressure	0.5	0.5	0.5	0.5	0.5	0.5
Expansion vessel size (litre)	7	7	7	7	7	7
Temperature setting range (min to max) (°C)	35-80	35-80	35-80	35-80	35-80	35-80

Dimensions:

Product dimensions	mm
A Width	395
B Height	718
C Depth	284
Service clearances	
D Side	5
E Upper	200
F Lower	200*
G Front - for operation	6*
Front - for servicing	450

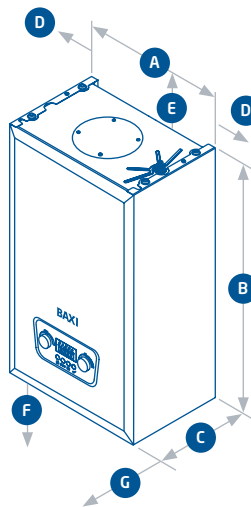

Compatible with:



Baxi uSense 2
See page 66



Hot water cylinders including the Megaflo Solar PV range
See pages 46-47

* These are minimum recommended dimensions, greater clearance will aid installation and maintenance

For more information visit www.baxi.co.uk/professional/products

SCAN ME



Electric boilers

Amptec

Slimline electric flow boiler designed to heat radiators or underfloor heating in smaller spaces like flats, garages and loft conversions, as well as high-rise, multi-occupancy dwellings. Perfect for homes off the mains gas network or for refurbishing old properties with flue restrictions.



4-12kW outputs



99.8% efficient



Slimline design perfect for limited space

Technical information	4kW radiator	6kW radiator	9kW radiator	11kW radiator	12kW radiator
Product code	95:022:001	95:022:002	95:022:003	95:022:004	95:022:005
Electrical input max	4kW @ 240V 3.7kW @ 230V	6kW @ 240V 5.5kW @ 230V	9kW @ 240V 8.3kW @ 230V	11kW @ 240V 10.1kW @ 230V	12kW @ 240V 11kW @ 230V
Electrical supply voltage (V)	220-240	220-240	220-240	220-240	220-240
Electrical supply frequency (Hz)	50	50	50	50	50
220V/Btu	3.5kW/11,900	5kW/17,000	7.5kW/25,600	9kW/30,700	10kW/34,000
240V/Btu	4kW/13,600	6kW/20,400B	9kW/30,700	11kW/37,500	12kW/40,900
Over temperature trips (°C)	95 and 100	95 and 100	95 and 100	95 and 100	95 and 100
Water content (litres)	1.3	1.3	1.3	1.3	1.3
Recommended Δt across boiler (°C)	5-10	5-10	5-10	5-10	5-10
Maximum operating pressure (bar)	3	3	3	3	3
Output temperature control range (°C)	65 to 80	65 to 80	65 to 80	65 to 80	65 to 80
Minimum flow rate (l/min)	6	6	12	12	12

Dimensions:

Product dimensions	mm
A Width	90
B Height	1,050
C Depth	90
Service clearances	
D Side	50*

* Please note, 50mm minimum clearance each side of the boiler is required

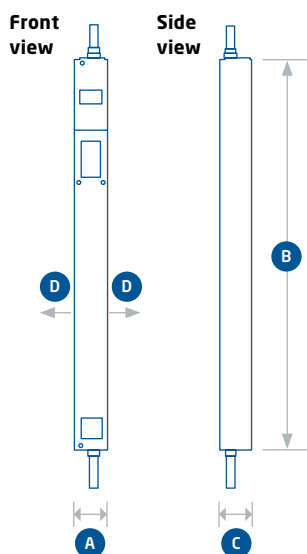

Compatible with:



SCAN ME



For more information visit www.baxi.co.uk/professional/products

Electric boilers

Electromax

All-in-one electric flow boiler and 180 litre direct cylinder system, designed for small homes off mains gas. The Electromax is factory tested for reliability, quality and safety and is delivered pre-plumbed for a quick installation.



Cylinder covered by a 10 year warranty
2 years for the boiler



99.8% efficient



One-hour booster can heat 57 litres of water

Technical information	6kW radiator	9kW radiator	9kW underfloor	6kW underfloor
Product code	95:022:234	95:022:236	95:022:226	95:022:227
DHW cylinder				
Off peak immersion heater input (kW)	3 @ 240V 2.8 @ 230V	3 @ 240V 2.8 @ 230V	3 @ 240V 2.8 @ 230V	3 @ 240V 2.8 @ 230V
Boost immersion heater input (kW)	3 @ 240V 2.8 @ 230V	3 @ 240V 2.8 @ 230V	3 @ 240V 2.8 @ 230V	3 @ 240V 2.8 @ 230V
Rated pressure (bar)	6	6	6	6
Pressure Reducing valve [†] (bar)	3.5	3.5	3.5	3.5
Capacity (litres)	180	180	180	180
DHW expansion vessel (litres/bar)	18/3.5	18/3.5	18/3.5	18/3.5
Temperature/pressure relief valve (°C/bar)	90/10	90/10	90/10	90/10
Combined thermostat (°C)	10-70	10-70	10-70	10-70
Resettable thermal cut-out (°C)	85	85	85	85
Minimum Insulation Thickness (mm)	40	40	40	40
Heat up time off peak Δt 45°C (mins)	180	180	180	180
Heat up time off peak Δt 50°C (mins)	200	200	200	200
First hour performance 3kW boost element Δt 45°C (litres)	57	57	57	57
Heat loss (kWh/24hr)	1.95	1.95	1.95	1.95

* 300mm minimum clearance must be allowed above the unit to allow for Top Panel access

** 50mm minimum clearance must be allowed at either side of the unit

† Integral with cold water combination valve

SCAN ME



For more information visit www.baxi.co.uk/professional/products



Electric boiler and primary circuit

	6kW radiator	9kW radiator	9kW underfloor	6kW underfloor
Maximum electrical input (kW)	6 @ 240V 5.5 @ 230V	9 @ 240V 8.3 @ 230V	9 @ 240V 8.3 @ 230V	6 @ 240V 5.5 @ 230V
Electrical supply voltage (V)	220-240	220-240	220-240	220-240
Electrical supply frequency (Hz)	50	50	50	50
Internal fuse rating - pump supply (Amps)	2	2	2	2
Primary system operating pressure - min (bar)	1	1	1	1
Primary system pressure relief valve setting (bar)	3	3	3	3
Primary system expansion vessel (litres/bar)	12/1	12/1	12/1	12/1
Primary flow temperature radiator model (°C)	65-80	65-80	65-80	65-80
Primary flow temperature underfloor model (°C)	30-60	30-60	30-60	30-60

Dimensions:

Product dimensions	mm
A Height	1,476
B Width	550
C Depth	600
Service clearances	
D Upper	300*
E Side	50**

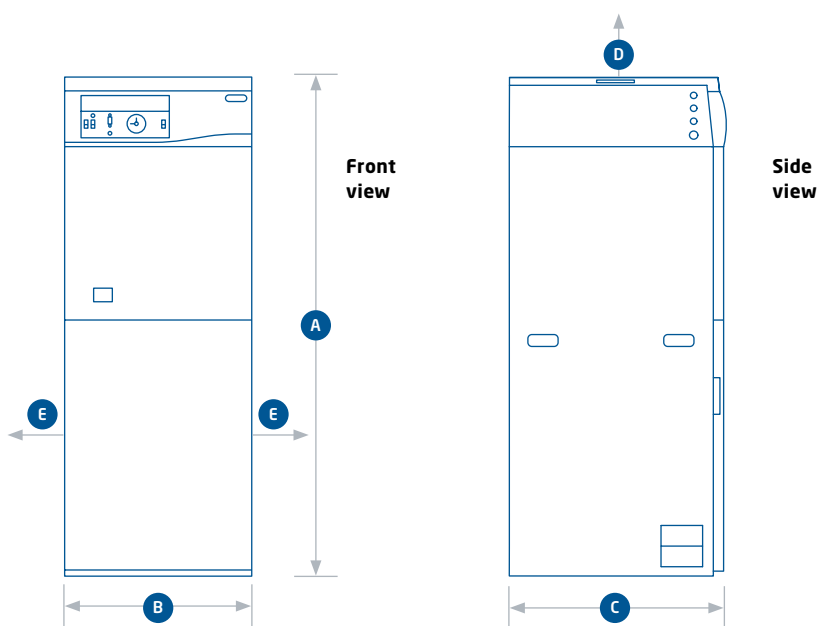

Cylinders

Our comprehensive range of Baxi and Megaflo cylinders are the perfect fit for homes of all kinds. Created by hot water experts Heatrae Sadia, our cylinders deliver a level of quality and performance you can rely on.

Baxi range

Baxi's streamlined, floor-mounted Indirect and Direct hot water cylinders can be installed quickly and easily, even in small spaces. With exceptionally fast recovery times thanks to the coil-in-coil heat exchanger, Baxi cylinders are sure to deliver reliable hot water across multiple outlets, without the need for shower pumps or tanks.

Megaflo range

With a complete range of powerful yet efficient cylinder options designed around modern lifestyles, the Megaflo range is the obvious choice for both homes and commercial buildings. Each floor-mounted unit is simple to install, even in the smallest of spaces, with fast heat recovery and exceptional flow rates, even at low pressures.

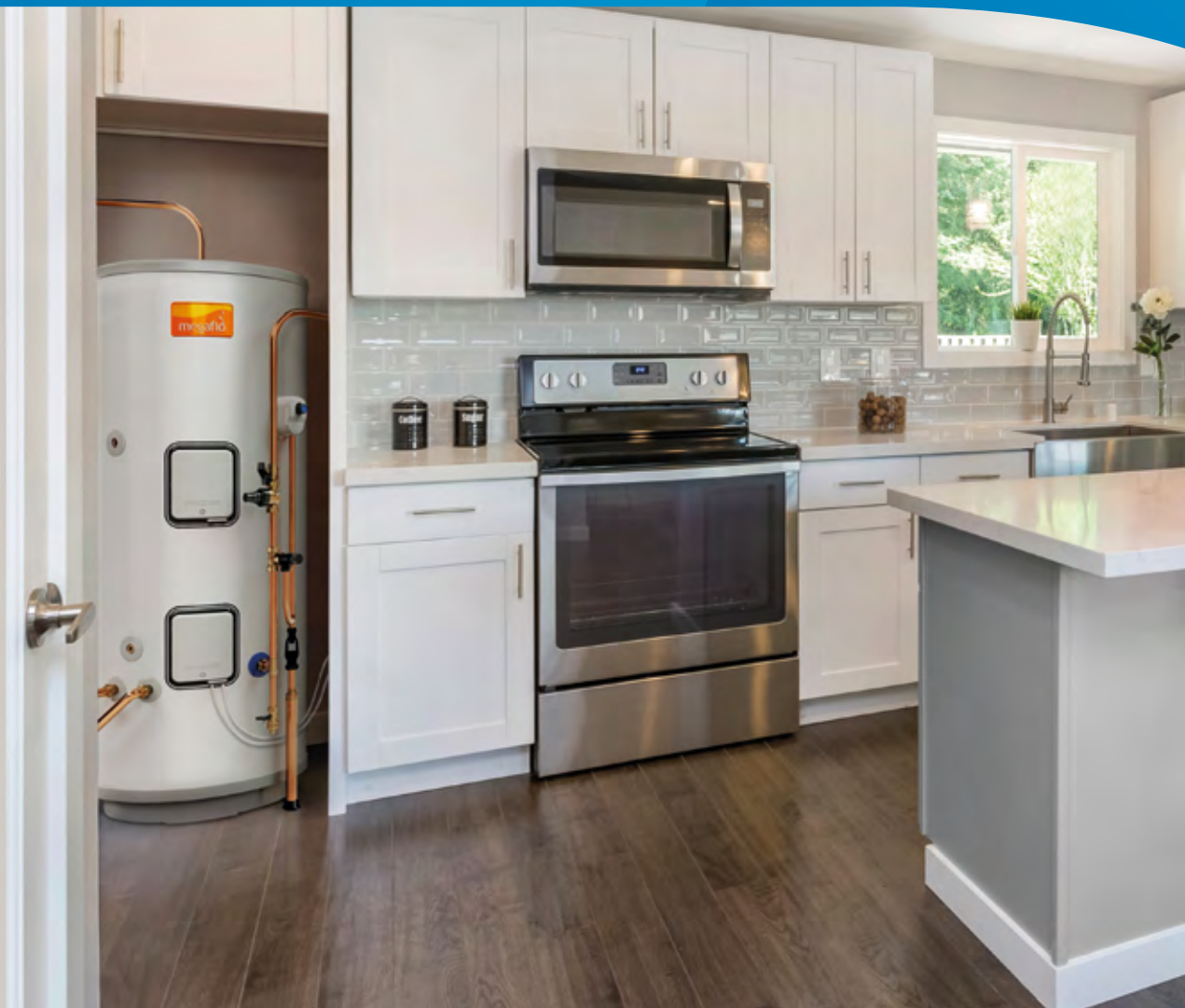

In this section

- Baxi Indirect **30**
- Baxi Direct **32**
- Megaflo Eco Indirect **34**
- Megaflo Eco Direct **36**
- Megaflo Eco SystemFit **38**
- Megaflo Eco SystemReady **40**
- Megaflo Eco Solar Indirect **42**
- Megaflo Eco Solar Direct **44**
- Megaflo Eco Solar PV Ready Indirect **46**
- Megaflo Eco Solar PV Ready Direct **47**
- Cylinder litreage matrix **48**

For Baxi ASHP cylinders
please see pages 60-62



Did you know?

Our cylinders feature a coil-in-coil heat exchanger, ensuring rapid heat-up times of as little as ten minutes for some models.

Hot water cylinders

Baxi Indirect

The Baxi Indirect offers exceptional maximum flow rates for outstanding hot water performance, without the need for shower pumps or tanks.



2 WARRANTY
TWO YEARS
AS STANDARD

15 WARRANTY
FIFTEEN YEARS*
ON THE INNER
STAINLESS STEEL TANK



125 to 300 litre volumes



Delivers up to 76 litres per minute at 3 bar pressure



50mm injected foam insulation

Technical information	125i	145i	170i	210i	250i	300i
Product code	7798178	7798179	7798180	7798181	7798182	7798183
Nominal capacity	125	145	170	210	250	300
Coil rating (@15l/min at 80) (kW)	11.6	11.8	12.5	12.8	13	11.8
Heat-up times (@15l/min at 80) (mins)	31	35	40	45	54	65
Heat loss (kWh/24h)	1.28	1.39	1.6	1.82	1.84	2.18
ErP rating	C	C	C	C	C	C
Mix water delivery to 40°C (litres)	176	197	233	258	320	386
Max mains pressure (bar)	16	16	16	16	16	16
Max design pressure (bar)	8	8	8	8	8	8
Operating pressure (bar)	3	3	3	3	3	3
Max primary pressure (bar)	10	10	10	10	10	10
Expansion relief valve setting (bar)	8	8	8	8	8	8
T&P valve setting (°C/bar)	90/10	90/10	90/10	90/10	90/10	90/10
Immersion heater electrical rating (kW @240V)	3	3	3	3	3	3

Compatible with:



Baxi 400, 600 and 800 Heat
See pages 16-21



Baxi 600 and 800 System 2
See pages 12-15

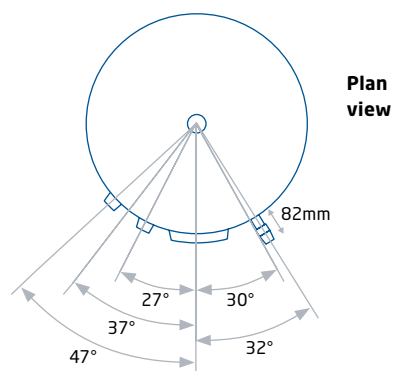
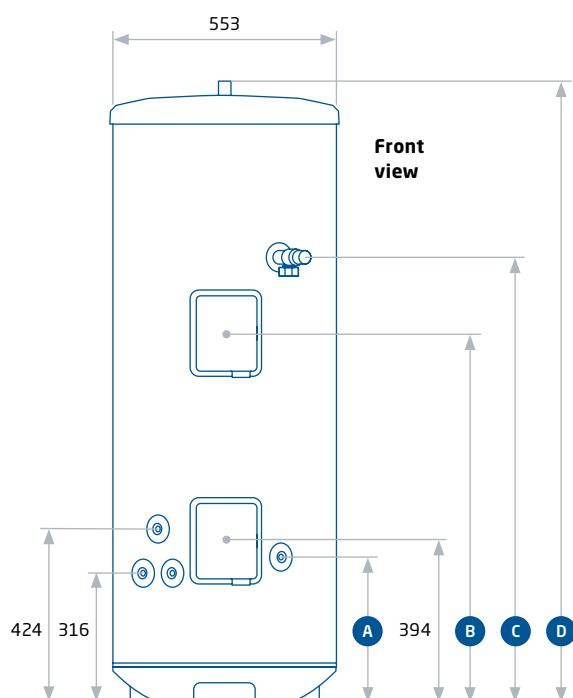

Dimensions:

Product dimensions	125i	145i	170i	210i	250i	300i
A Cold water inlet (mm)	355	355	355	356	356	355
B Immersion heater (mm)	n/a	n/a	n/a	900	1,100	1,418
C T&P relief value (mm)	728	883	1,008	1,084	1,309	1,574
D Height (mm)	1,131	1,258	1,414	1,516	1,767	2,081
Weight dry (kg)	34	38	41	41	51	54

For specification guides and more information, visit baxi.co.uk/professional/products/cylinders

SCAN ME



Hot water cylinders

Baxi Direct

The Baxi Direct offers the same reliable performance and efficiencies as our Indirect models. It's available in a range of volumes between 125 and 300 litres to suit all house sizes and hot water needs.



125 to 300 litre volumes



Delivers up to 76 litres per minute at 3 bar pressure



50mm injected foam insulation

Technical information	125d	145d	170d	210d	250d	300d
Product code	7798172	7798173	7798174	7798175	7798176	7798177
Nominal capacity	125	145	170	210	250	300
Immersion heater rating (kW)	2 x 3	2 x 3	2 x 3	2 x 3	2 x 3	2 x 3
Heat up times (lower immersion) (mins)	139	175	193	205	267	309
Heat up times (bottom immersion) (mins)	65	83	87	89	96	92
Heat up times (both immersion) (mins)	62	79	88	90	98	93
ErP rating	C	C	C	C	C	C
Mix water delivery to 40°C (litres)	176	197	233	258	320	386
Max mains pressure (bar)	16	16	16	16	16	16
Max design pressure	8	8	8	8	8	8
Operating pressure (bar)	3	3	3	3	3	3
Max primary pressure (bar)	10	10	10	10	10	10
Expansion relief valve setting (bar)	8	8	8	8	8	8
T&P valve setting (°C/bar)	90/10	90/10	90/10	90/10	90/10	90/10

Compatible with:



Amptec electric system boiler range

See pages 24-25

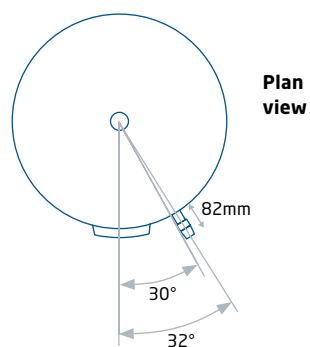
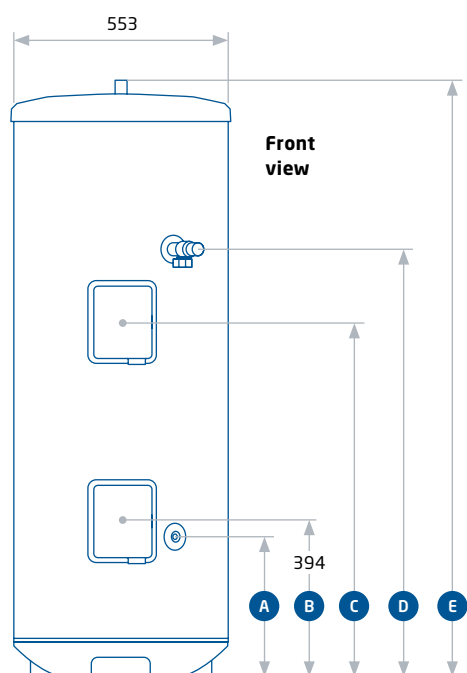

Dimensions:

Product dimensions	125d	145d	170d	210d	250d	300d
A Cold water inlet (mm)	356	356	356	356	356	355
B Immersion heater (mm)	394	394	394	394	395	396
C Boost immersion heater (mm)	668	680	804	900	1,110	1,413
D T&P relief value (mm)	782	883	1,008	1,084	1,309	1,574
E Height (mm)	1,131	1,258	1,414	1,516	1,767	2,081
Weight dry (kg)	25	31	34	38	46	56

SCAN ME



For specification guides and more information, visit baxi.co.uk/professional/products/cylinders

Hot water cylinders

Megaflo Eco Indirect

Complete with its tried and tested internal expansion system, Megaflo Eco offers a number of features that place it well ahead of the competition on performance, quality and reliability.

2 WARRANTY
TWO YEARS
AS STANDARD

30 WARRANTY
THIRTY YEARS*
ON THE INNER
STAINLESS STEEL TANK

B
ENERGY
RATING

C
ENERGY
RATING



70-300 litres nominal capacity



60mm injected foam insulation



Deliver up to 76 litres per minute of hot water at 3 bar pressure

Technical information	70i	125i	145i	170i	210i	250i	300i
Product code	95050461	95050463	95050465	7817127	7817128	7817129	7817130
Nominal capacity	70	125	145	170	210	250	300
Coil rating (@15l/min at 80°C)	19.8	19.5	20.9	19.4	19.4	19.5	20.5
Heat up times (mins)	9.6	15.3	17	23.3	24.1	26.8	33.1
Heat loss (kWh/24h)	0.91	1.05	1.18	1.2	1.42	1.61	1.69
ErP rating	B	B	B	B	B	C	C
Mixed water at 40°C V40 in litres	87.4	139	159	197	200	240	284
Max mains pressure	1.6MPa (16 bar)						
Max design pressure	0.8MPa (8 bar)						
Operating pressure	0.3MPa (3 bar)						
Max primary pressure	1MPa (10 bar)						
Expansion relief valve setting	0.8MPa (8 bar)						
T&P valve setting	1MPa (10 bar)						
Immersion heater rating (AC supply only)	3kW @ 240V, 2.8kW @ 230V						

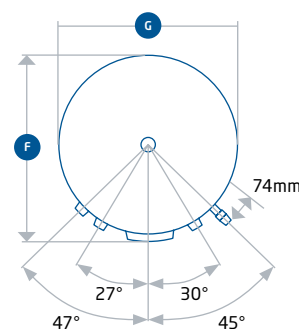
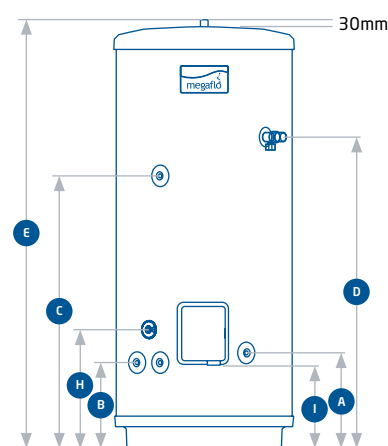

Product dimensions	70i	125i	145i	170i	210i	250i	300i
A DHW inlet (mm)	414	414	414	414	414	414	414
B Primary coil connections (mm)	373	373	373	373	373	373	373
C Secondary return (mm)	n/a	709	810	934	1,011	1,238	1,526
D T&P relief valve (mm)	495	794	895	1,020	1,095	1,323	1,574
E Height (mm)	802	1,102	1,229	1,384	1,486	1,738	2,053
F Depth (mm)	600	600	600	600	600	600	600
G Width (mm)	579	579	579	579	579	579	579
H Sensor pocket (mm)	410	410	410	410	410	410	410
I Cable entry lower (mm)	275	275	275	275	275	275	275

SCAN ME



For specification guides and more information, visit www.megaflo.com

Rewarding your loyalty

Our installer loyalty scheme, designed to prioritise you, support you and reward you.



Earn reward points for eligible product registrations – including boilers, cylinders and air source heat pumps.



Access the Baxi Toolbelt App for Gas Safe registered installers.



Get priority engineer call-outs.



Receive automated service reminders and expert advice.



Appear on the Baxi Find an Installer listing.



Enjoy the premium benefits of being a Baxi Approved Installer, when you register at least 20 eligible products a year.



Sign up today at baxiworks.co.uk



BAXI
Works

Hot water cylinders

Megaflo Eco Direct

Complete with its tried and tested internal expansion system, Megaflo Eco offers a number of features that place it well ahead of the competition on performance, quality and reliability.

2 WARRANTY
TWO YEARS
AS STANDARD

30 WARRANTY
THIRTY YEARS*
ON THE INNER
STAINLESS STEEL TANK



70-300 litres nominal capacity



60mm injected foam insulation



Deliver up to 76 litres per minute of hot water at 3 bar pressure

Technical information	70d	125dd	145dd	170dd	210dd	250dd	300dd
Product code	95050460	95050462	95050464	95050466	95050468	95050470	95050473
Nominal capacity	70	125	145	170	210	250	300
Coil rating (@15l/min at 80°C)	n/a	n/a	n/a	n/a	n/a	n/a	n/a
Heat up times (mins)	92	71	79	93	102	121	146
Heat loss (kWh/24h)	0.91	1.05	1.18	1.2	1.42	1.61	1.69
ErP rating	B	B	C	C	C	C	C
Mixed water at 40°C V40 in litres	78	167	183	218	241	307	359
Max mains pressure	1.6MPa (16 bar)						
Max design pressure	0.8MPa (8 bar)						
Operating pressure	0.3MPa (3 bar)						
Max primary pressure	n/a						
Expansion relief valve setting	0.8MPa (8 bar)						
T&P valve setting	1MPa (10 bar)						
Immersion heater rating (AC supply only)	3kW @ 240V, 2.8kW @ 230V						

Dimensions:

Product dimensions	70d	125dd	145dd	170dd	210dd	250dd	300dd
A DHW inlet (mm)	414	414	414	414	414	414	414
B Cable entry lower (mm)	275	275	275	275	275	275	275
C Cable entry upper (mm)	n/a	549	580	705	801	1,009	1,313
D T&P relief valve (mm)	495	794	895	1,020	1,095	1,323	1,574
E Height (mm)	802	1,102	1,229	1,384	1,486	1,738	2,053
F Depth (mm)	600	600	600	600	600	600	600
G Width (mm)	579	579	579	579	579	579	579

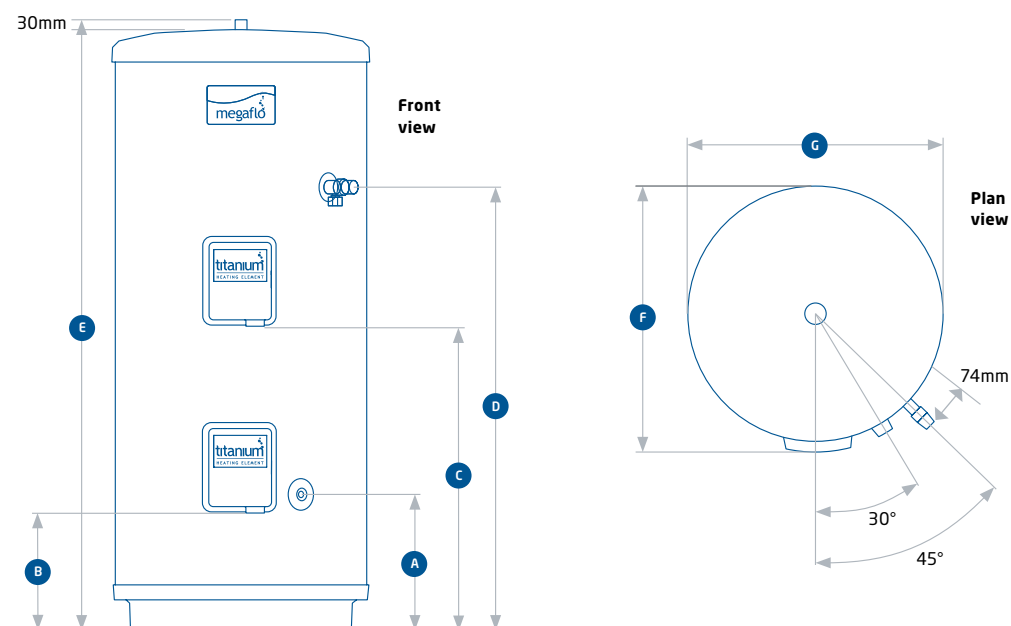

Technical information	210ddd	250ddd	300ddd	210dddd	250dddd	300dddd
Product code	95050480	95050471	95050474	95050476	95050477	95050478
Nominal capacity	210	250	300	210	250	300
Coil rating (@15l/min at 80°C)	n/a	n/a	n/a	n/a	n/a	n/a
Heat up times (mins)	68	81	97	51	60	73
Heat loss (kWh/24h)	1.42	1.61	1.69	1.42	1.61	1.69
ErP rating	C	C	C	C	C	C
Mixed water at 40°C V40 in litres	241	307	359	241	307	359
Max mains pressure	1.6MPa (16 bar)					
Max design pressure	0.8MPa (8 bar)					
Operating pressure	0.3MPa (3 bar)					
Max primary pressure	n/a					
Expansion relief valve setting	0.8MPa (8 bar)					
T&P valve setting	1MPa (10 bar)					
Immersion heater rating (AC supply only)	3kW @ 240V, 2.8kW @ 230V					

Dimensions:

Product dimensions	210ddd	250ddd	300ddd	210dddd	250dddd	300dddd
A DHW inlet (mm)	414	414	414	414	414	414
B Cable entry lower (mm)	275	275	275	275	275	275
C Cable entry upper (mm)	801	1,009	1,313	801	1,009	1,313
D T&P relief valve (mm)	1,095	1,323	1,574	1,095	1,323	1,574
E Height (mm)	1,486	1,738	2,053	1,486	1,738	2,053
F Depth (mm)	600	600	600	600	600	600
G Width (mm)	579	579	579	579	579	579

For specification guides and more information, visit www.megafló.com

SCAN ME



Hot water cylinders

Megaflo Eco SystemFit

Our Megaflo Eco SystemFit goes one step further than our standard Megaflo Eco by adding factory-fitted plumbing and wiring, making it ready for installation with a heat only boiler – not only reducing installation time but also providing a consistently neater appearance.



125-300 litres volumes



Pre-plumbed and pre-wired for fast installation



Deliver up to 76 litres per minute of hot water at 3 bar pressure

Technical information	125sf	145sf	170sf	210sf	250sf	300sf
Product code	95050450	95050451	95050452	95050453	95050454	95050455
Nominal capacity	125	145	170	210	250	300
Coil rating (@15l/min at 80°C)	19.5	20.9	19.4	19.4	19.5	20.5
Heat up times (mins)	15.3	17	23.3	24.1	26.8	33.1
Heat loss (kWh/24h)	1.05	1.18	1.2	1.42	1.61	1.69
ErP rating	B	B	B	B	C	C
Mixed water at 40°C V40 in litres	139	159	197	200	240	284
Max mains pressure	1.6MPa (16 bar)					
Max design pressure	0.8MPa (8 bar)					
Operating pressure	0.3MPa (3 bar)					
Max primary pressure	1MPa (10 bar)					
Expansion relief valve setting	0.8MPa (8 bar)					
T&P valve setting	1MPa (10 bar)					
Immersion heater rating (AC supply only)	3kW @ 240V, 2.8kW @ 230V					

Compatible with:

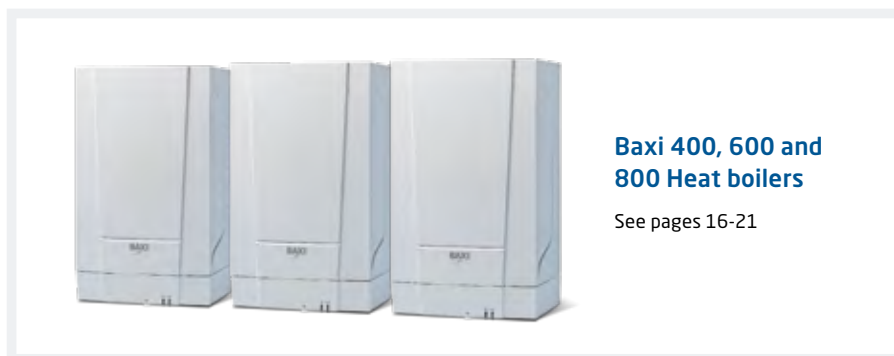

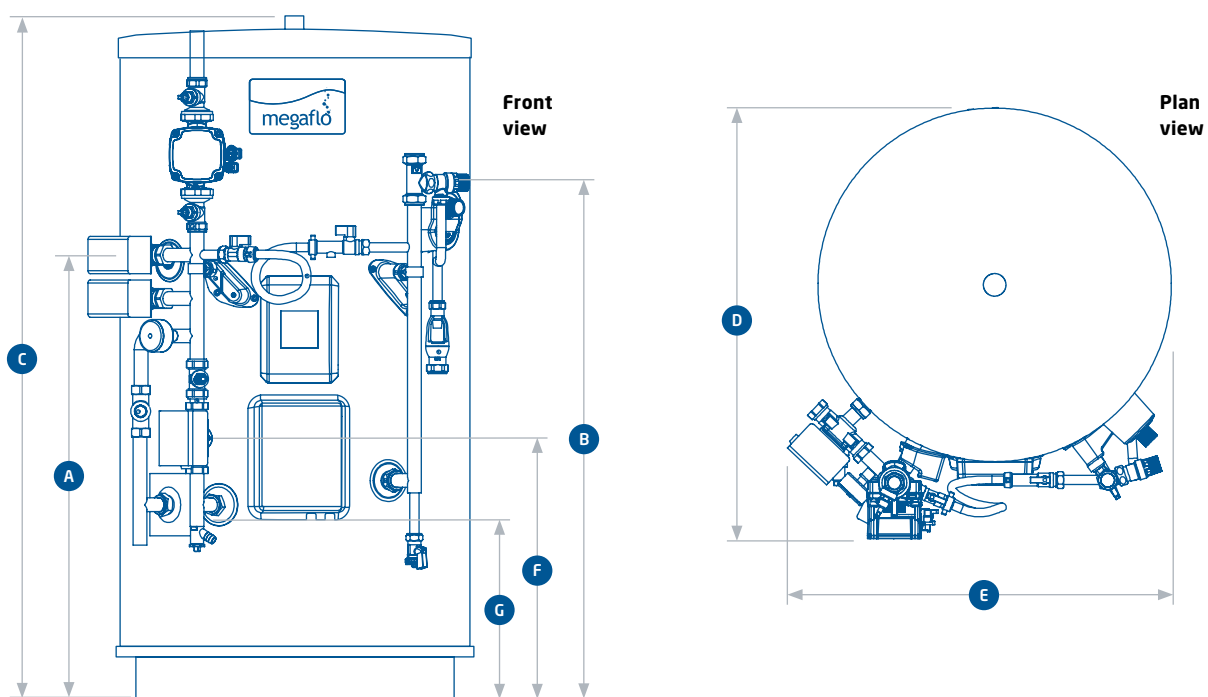

Dimensions:

Product dimensions	125sf	145sf	170sf	210sf	250sf	300sf
A Secondary return (mm)	709	810	934	1,011	1,238	1,526
B T&P relief valve (mm)	794	895	1,020	1,095	1,323	1,574
C Height (mm)	1,102	1,229	1,384	1,486	1,738	2,053
D Depth (mm)	720	720	720	720	720	720
E Width (mm)	630	630	630	630	630	630
F Sensor pocket (mm)	410	410	410	410	410	410
G Cable entry lower (mm)	275	275	275	275	275	275

For specification guides and more information, visit www.megaflo.com

SCAN ME



Hot water cylinders

Megaflo Eco SystemReady

Megaflo Eco SystemReady is designed for installation with system boilers and has optional programmer accessories to suit different customer needs. Complete with a tapping for connection of second heating zone.



125-300 litres volumes



Pre-plumbed and pre-wired for fast installation



Deliver up to 76 litres per minute of hot water at 3 bar pressure

Technical information	125sb	145sb	170sb	210sb	250sb	300sb
Product code	95050497	95050498	95050499	95050500	95050501	95050502
Nominal capacity	125	145	170	210	250	300
Coil rating (@15l/min at 80°C)	19.5	20.9	19.4	19.4	19.5	20.5
Heat up times (mins)	15.3	17	23.3	24.1	26.8	33.1
Heat loss (kWh/24h)	1.05	1.18	1.2	1.42	1.61	1.69
ErP rating	B	B	B	B	C	C
Mixed water at 40°C V40 in litres	139	159	197	200	240	284
Max mains pressure	1.6MPa (16 bar)					
Max design pressure	0.8MPa (8 bar)					
Operating pressure	0.3MPa (3 bar)					
Max primary pressure	1MPa (10 bar)					
Expansion relief valve setting	0.8MPa (8 bar)					
T&P valve setting	1MPa (10 bar)					
Immersion heater rating (AC supply only)	3kW @ 240V, 2.8kW @ 230V					

Compatible with:

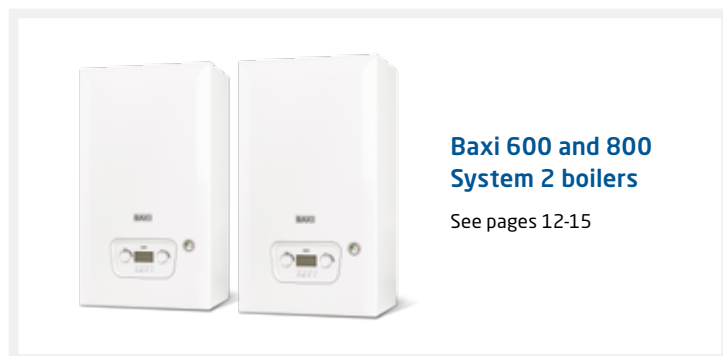

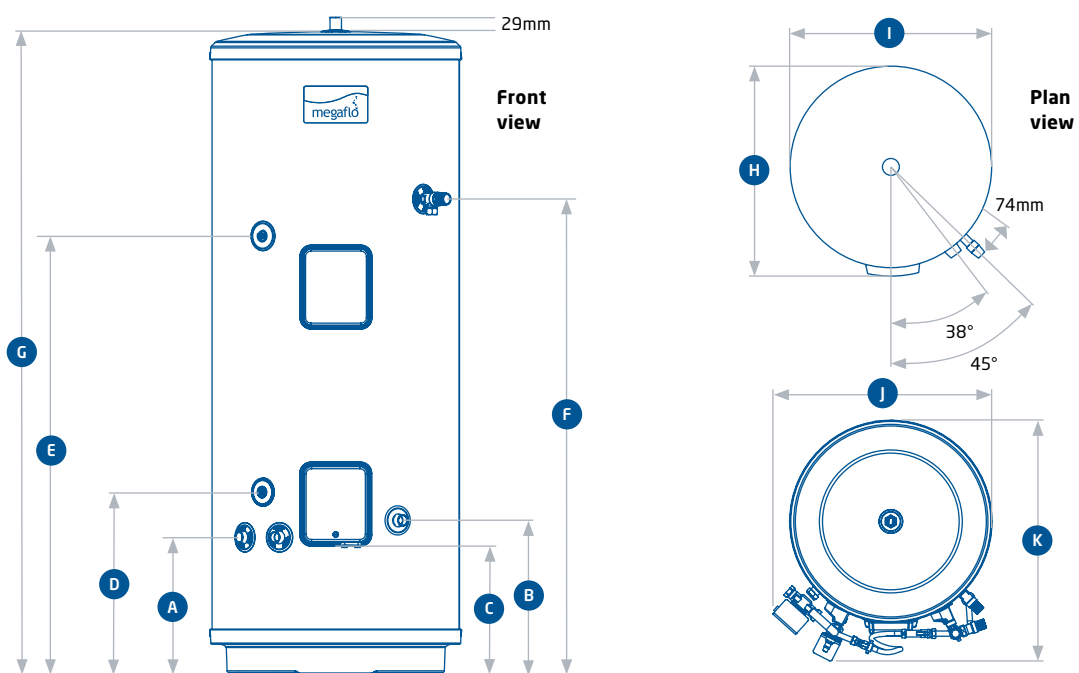

Dimensions:

Product dimensions	125sb	145sb	170sb	210sb	250sb	300sb
A Primary return (mm)	316	316	316	316	316	316
B Cold inlet (mm)	355	355	355	355	355	355
C Cable entry lower (mm)	310	310	310	310	310	310
D Sensor pocket (mm)	410	410	410	410	410	410
E Secondary return (mm)	709	810	934	1,011	1,238	1,526
F T&P relief valve (mm)	794	895	1,020	1,095	1,323	1,574
G Height (mm)	1,102	1,229	1,384	1,486	1,738	2,053
H Depth (mm)	710	710	710	710	710	710
I Width (mm)	579	579	579	579	579	579
J Minimum width requirement (mm)	690	690	690	690	690	690
K Minimum depth requirement (mm)	710	710	710	710	710	710

SCAN ME



For specification guides and more information, visit www.megaflor.com

Hot water cylinders

Megaflo Eco Solar Indirect

The Megaflo Eco Solar Indirect provides an abundance of hot water for fast-filling baths and invigorating powerful showers without the need for pumps or tanks, whilst keeping running costs to a minimum by harnessing the sun's energy when used in conjunction with a solar thermal plate collector or an evacuated tube package.



70-300 litres nominal capacity



60mm injected foam insulation



Deliver up to 76 litres per minute of hot water at 3 bar pressure

Technical information	190si	210si	250si	300si
Product code	95050511	95050513	95050515	95050517
Nominal capacity	190	210	250	300
Coil rating (@15l/min at 80°C)	19.7	19.7	20.7	22.2
Heat up times (mins)	14.8	14.3	19.5	17.8
Heat loss (kWh/24h)	1.32	1.41	1.56	1.84
ErP rating	C	C	C	C
Mixed water at 40°C V40 in litres	191	202	248	300
Max mains pressure		1.6MPa (16 bar)		
Max design pressure		0.8MPa (8 bar)		
Operating pressure		0.3MPa (3 bar)		
Max primary pressure		1MPa (10 bar)		
Expansion relief valve setting		0.8MPa (8 bar)		
T&P valve setting		1MPa (10 bar)		
Immersion heater rating (AC supply only)		3kW @ 240V, 2.8kW @ 230V		

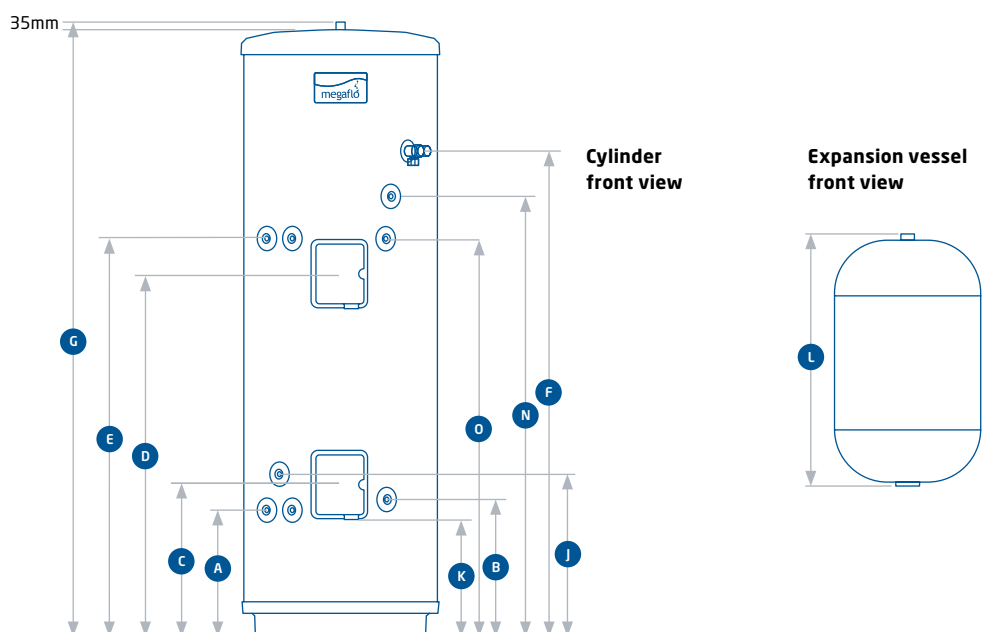

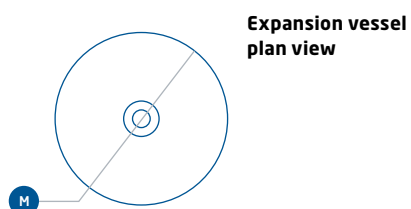
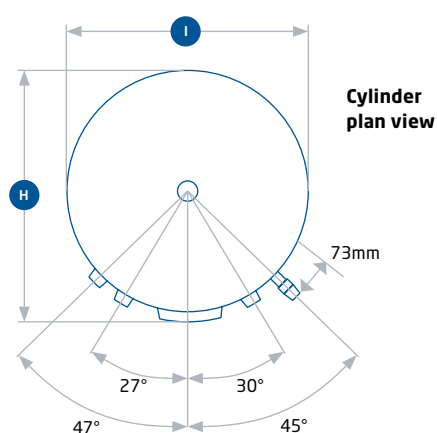

Dimensions:

Product dimensions	190si	210si	250si	300si
A Primary coil connections (mm)	373	373	373	373
B Inlet (mm)	454	454	454	454
C Solar control housing (mm)	795	932	995	1,289
D Back up element control housing (mm)	814	949	1,068	1,255
E Secondary coil connections (mm)	925	1,095	1,258	1,573
F T&P valve (mm)	925	1,184	1,441	1,693
G Height (mm)	1,229	1,489	1,802	2,053
H Depth (mm)	600	600	600	600
I Width (mm)	579	579	579	579
J Sensor Pocket (mm)	410	410	410	410
K Cable entry lower (mm)	275	275	275	275
L Portable water expansion vessel height (mm)	492	492	492	492
M Portable water expansion vessel diameter (mm)	280	280	280	280
N Secondary return	925	1,095	1,258	1,573
O Sensor Pocket (mm)	825	995	1,156	1,473

SCAN ME



For specification guides and more information, visit www.megaflo.com

Hot water cylinders

Megaflo Eco Solar Direct

The Megaflo Eco Solar Direct provides an abundance of hot water for fast-filling baths and invigorating powerful showers without the need for pumps or tanks, whilst keeping running costs to a minimum by harnessing the sun's energy when used in conjunction with a solar thermal plate collector or an evacuated tube package.



70-300 litres nominal capacity



60mm injected foam insulation



Deliver up to 76 litres per minute of hot water at 3 bar pressure

Technical information	170sdd	210sdd	260sdd	300sdd
Product code	95050527	95050512	95050528	95050516
Nominal capacity	170	210	260	300
Coil rating (@15l/min at 80°C)	n/a	n/a	n/a	n/a
Heat up times (mins)	86	63	85	99
Heat loss (kWh/24h)	1.25	1.41	1.63	1.84
ErP rating	C	C	C	C
Mixed water at 40°C V40 in litres	213	208	271	309
Max mains pressure		1.6MPa (16 bar)		
Max design pressure		0.8MPa (8 bar)		
Operating pressure		0.3MPa (3 bar)		
Max primary pressure		1MPa (10 bar)		
Expansion relief valve setting		0.8MPa (8 bar)		
T&P valve setting		1MPa (10 bar)		
Immersion heater rating (AC supply only)		3kW @ 240V, 2.8kW @ 230V		

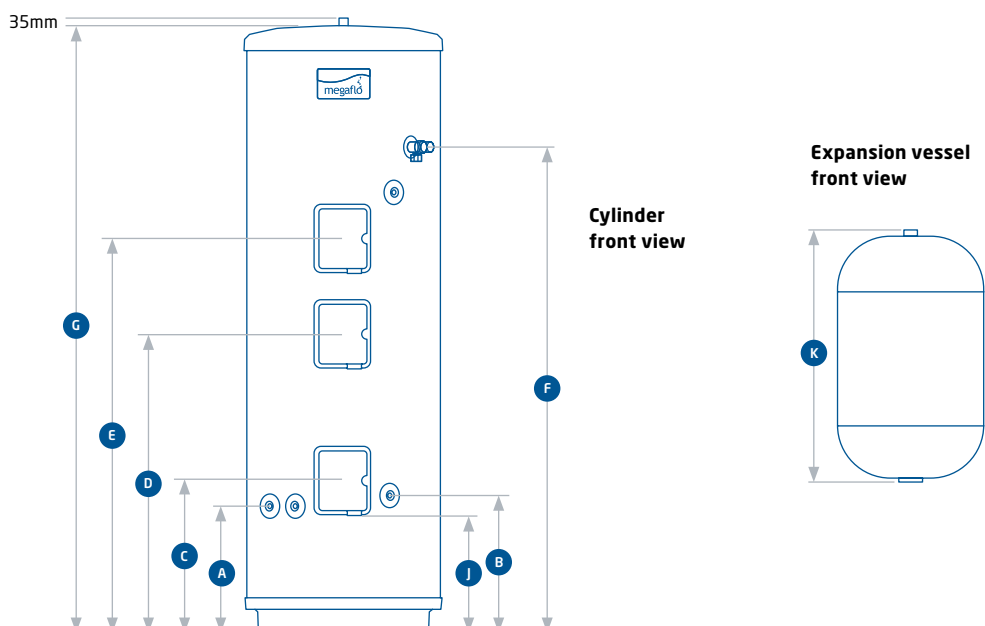

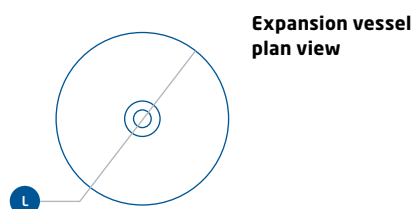
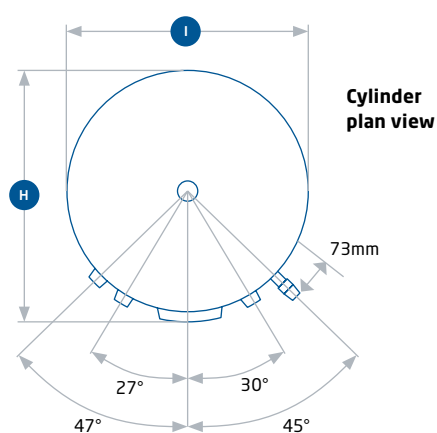

Dimensions:

Product dimensions	170sd	210sdd	260sdd	300sdd
A Primary coil connections (mm)	373	373	373	373
B Inlet (mm)	454	454	454	454
C Solar control housing (mm)	795	932	995	1,289
D Back up element control housing (mm)	794	829	888	983
E Auxiliary element control housing (mm)	n/a	1,103	1,167	1,444
F T&P valve (mm)	925	1,184	1,441	1,693
G Height (mm)	1,229	1,489	1,802	2,053
H Depth (mm)	600	600	600	600
I Width (mm)	579	579	579	579
J Cable entry lower (mm)	275	275	275	275
K Portable water expansion vessel height (mm)	492	492	492	492
L Portable water expansion vessel diameter (mm)	280	280	280	280

SCAN ME



For specification guides and more information, visit www.megaflco.com

Hot water cylinders

Megaflo Eco Solar Indirect PV Ready

The Megaflo Eco Solar PV Ready takes the energy harvested by PV panels on the roof and transfers it directly to the cylinder delivering free hot water.

2 WARRANTY
TWO YEARS
AS STANDARD

30 WARRANTY
THIRTY YEARS*
ON THE INNER
STAINLESS STEEL TANK

B
ENERGY
RATING

C
ENERGY
RATING



**170-300 litres
nominal capacity**



**Fully-wired Solar
iBoost control**



**Deliver up to 76 litres per minute
of hot water at 3 bar pressure**

Technical information	170i	210i	250i	300i
Product code	95050350	95050351	95050352	95050353
Nominal capacity	170	210	250	300
Coil rating (@15l/min at 80°C)	19.4	19.4	19.5	20.5
Heat up times (mins)	23.3	24.1	26.8	33
Heat loss (kWh/24h)	1.2	1.42	1.61	1.69
ErP rating	B	B	C	C
Mixed water at 40°C V40 in litres	197	200	240	284
Max mains pressure	1.6MPa (16 bar)			
Max design pressure	0.8MPa (8 bar)			
Operating pressure	0.3MPa (3 bar)			
Max primary pressure	1MPa (10 bar)			
Expansion relief valve setting	0.8MPa (8 bar)			
T&P valve setting	1MPa (10 bar)			
Immersion heater rating (AC supply only)	3kW @ 240V, 2.8kW @ 230V			

Dimensions	170i	210i	250i	300i
A Cable entry lower (mm)	290	290	290	290
B DHW inlet (mm)	355	355	355	355
C Heater 1 control (mm)	703	796	1,008	1,312
D T&P relief valve (mm)	1,020	1,096	1,323	1,574
E Primary coil connections (mm)	316	316	316	316
F Boiler thermostat pocket (mm)	424	424	424	424
G Secondary return (mm)	935	1,011	1,238	1,526
H Solar PV control (mm)	950	1,052	744	744
I Height (mm)	1,383	1,485	1,736	2,051
J Depth (mm)	714	714	714	714
K Width (mm)	579	579	579	579

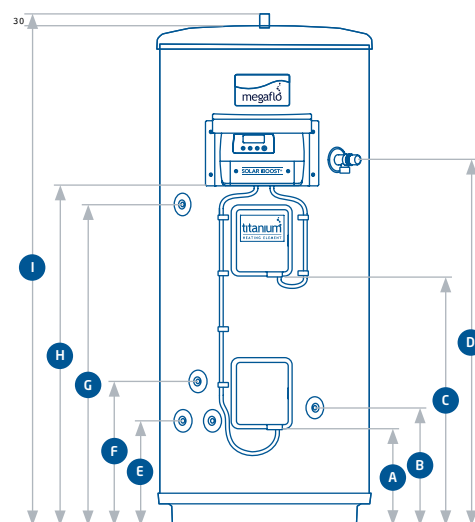

Front view

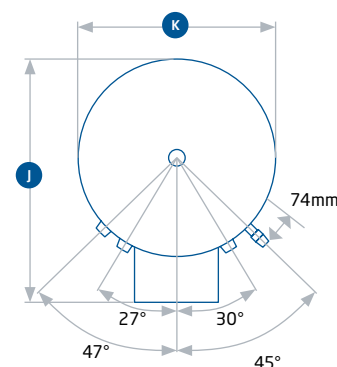

Plan view

SCAN ME



For specification guides and more information, visit www.megaflo.com

Hot water cylinders

Megaflo Eco Solar Direct PV Ready

The Megaflo Eco Solar PV Ready takes the energy harvested by PV panels on the roof and transfers it directly to the cylinder delivering free hot water.

2 WARRANTY
TWO YEARS
AS STANDARD

30 WARRANTY
THIRTY YEARS*
ON THE INNER
STAINLESS STEEL TANK

C
ENERGY
RATING



210-300 litres nominal capacity



Fully-wired Solar iBoost control



Deliver up to 76 litres per minute of hot water at 3 bar pressure

Technical information	210dd	250dd	300dd
Product code	95050354	95050355	95050356
Nominal capacity	210	250	300
Coil rating (@15l/min at 80°C)	n/a	n/a	n/a
Heat up times (mins)	89	96	92
Heat loss (kWh/24h)	1.05	1.18	1.2
ErP rating	C	C	C
Mixed water at 40°C V40 in litres	191	238	286
Max mains pressure		1.6MPa (16 bar)	
Max design pressure		0.8MPa (8 bar)	
Operating pressure		0.3MPa (3 bar)	
Max primary pressure		1MPa (10 bar)	
Expansion relief valve setting		0.8MPa (8 bar)	
T&P valve setting		1MPa (10 bar)	
Immersion heater rating (AC supply only)		3kW @ 240V, 2.8kW @ 230V	

Dimensions	210dd	250dd	300dd
A Cable entry lower (mm)	275	275	275
B DHW inlet (mm)	307	307	307
C Heater 1 control (mm)	801	1,008	1,312
D T&P relief valve (mm)	1,095	1,322	1,574
E Solar PV control (mm)	1,052	744	744
F Height (mm)	1,485	1,736	2,051
G Depth (mm)	714	714	714
H Width (mm)	579	579	579

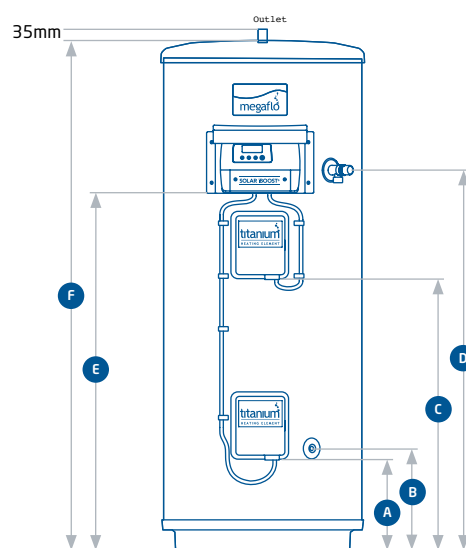

Front view

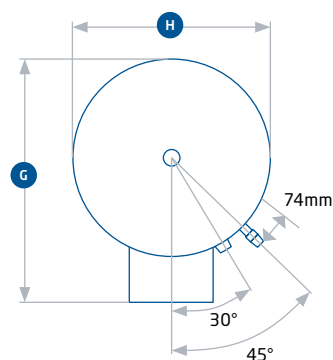

Plan view

For specification guides and more information, visit www.megaflo.com





SCAN ME







Hot water cylinders

Cylinder litreage matrix

Our comprehensive range factors in the individual needs of each installation, so you'll always find a Baxi or Megaflo cylinder that delivers the ultimate in performance and reliability for your project and budget.

	 70 Litres	 125 Litres	 145 Litres	 170 Litres	 190 Litres
Baxi Indirect cylinder		●	●	●	
Baxi Direct cylinder		●	●	●	
Megaflo Eco Indirect	●	●	●	●	
Megaflo Eco Direct	●	●	●	●	
Megaflo Eco SystemFit		●	●	●	
Megaflo Eco SystemReady		●	●	●	
Megaflo Eco Solar Indirect				●	
Megaflo Eco Solar Direct				●	
Megaflo Eco Solar PV Ready Indirect					●
Megaflo Eco Solar PV Ready Direct				●	
Baxi ASHP cylinder - see page 62					
Baxi ASHP Pre-plumbed cylinder - see page 60				●	

	 210 Litres	 250 Litres	 260 Litres	 300 Litres
Baxi Indirect cylinder	●	●		●
Baxi Direct cylinder	●	●		●
Megaflo Eco Indirect	●	●		●
Megaflo Eco Direct	●	●		●
Megaflo Eco SystemFit	●	●		●
Megaflo Eco SystemReady	●	●		●
Megaflo Eco Solar Indirect	●		●	●
Megaflo Eco Solar Direct	●		●	●
Megaflo Eco Solar PV Ready Indirect	●	●		●
Megaflo Eco Solar PV Ready Direct	●		●	●
Baxi ASHP cylinder - see page 62	●	●		●
Baxi ASHP Pre-plumbed cylinder - see page 60	●	●		●

For specification guides and more information, visit www.megaflo.com

SCAN ME



Solutions training

Our advanced training ensures you have the additional skills and knowledge that you need to deliver the next generation of heating and hot water solutions. Enabling you to work smarter, more efficiently and more profitably, taking you and your business to the next level.



Find a course today at baxi.co.uk/training



"Just wanted to say a huge thanks for the training day... The training guys were fantastic! I have always fitted your products but this has just proven what a fabulous company Baxi is. I will continue recommending your boilers to all my customers! Thanks so much."

J S Pinder, Plumbing and Heating, Sheffield



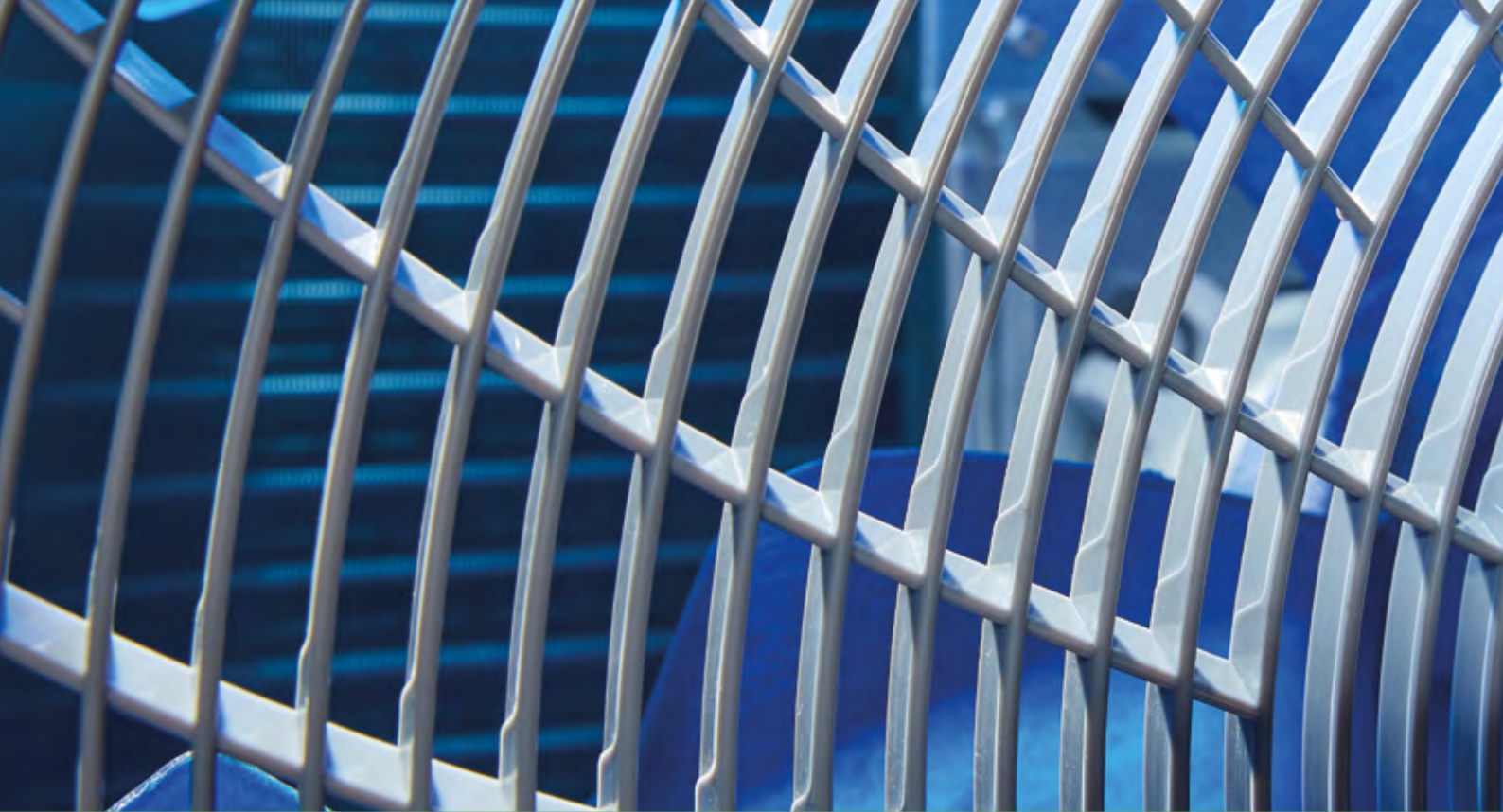

Air source heat pumps

Air source heat pumps (ASHPs) are an ultra-efficient alternative to conventional residential heating. They work by taking heat from the air, converting it into usable heat in the home.

Our ASHPs are available individually or with Baxi ASHP hot water cylinders, a range of accessories and smart controls – to offer a complete, packaged solution. A full solution also means a range of services to help and support you, from the system design throughout the installation and commissioning, to the after sales services.

Baxi offers:



Training to become a Baxi Heat Pump Installer (BHPI)



Options to discover MCS umbrella services enabling fully certified heat pump installations



The help and support of Baxi's nationwide fleet of service engineers



Being a phone call away from our Technical Support

Did you know?

We offer free on-site commissioning support for your first commission, as part of our ASHP training.



In this section

- Baxi HP60 ASHP **52**
- Baxi HP40 ASHP **56**
- Baxi ASHP Pre-plumbed cylinder **60**
- Baxi ASHP cylinder **62**

Air source heat pumps

Baxi HP60 ASHP

Efficient, quiet and low-carbon, the high temperature Baxi HP60 Monobloc Air Source Heat Pump is a smart fit for many homes. For a complete system, pair it with our cylinders and smart controls.



Up to 7 years enhanced warranty*



4-13kW outputs



Up to 75°C flow temperature



Excellent SCOP: up to 5.34

Technical information	4kW	6kW	8kW	11kW	13kW	11kWφ	13kWφ
Product code	7899694	7899695	7899696	7899697	7899699	7899698	7899700
Min/max operating range (°C)	-25/+35	-25/+35	-25/+35	-25/+35	-25/+35	-25/+35	-25/+35
Sound pressure level dB(A) @1m	40.0 dB(A)	40.0 dB(A)	41.0 dB(A)	44.0 dB(A)	44.0 dB(A)	44.0 dB(A)	44.0 dB(A)
Sound power level dB(A) (EN12102-1)	48.0 dB(A)	48.0 dB(A)	49.0 dB(A)	52.0 dB(A)	52.0 dB(A)	52.0 dB(A)	52.0 dB(A)
ErP @ 35°C	A+++	A+++	A+++	A+++	A+++	A+++	A+++
ErP @ 55°C	A+++	A+++	A+++	A++	A++	A++	A++
Power supply (V/Ph/Hz)	220-240/1/50	220-240/1/50	220-240/1/50	220-240/1/50	220-240/1/50	380-415/3/50	380-415/3/50
MCA (A)	12 A	14 A	18 A	25 A	28 A	8.5 A	9.5 A
TOCA (A)	15 A	15 A	19 A	31 A	31 A	11 A	11 A
MFA (A)	16 A	16 A	20 A	32 A	32 A	16 A	16 A
Flow/return connections	G 1"	G 1"	G 1 1/4"	G 1 1/4"	G 1 1/4"	G 1 1/4"	G 1 1/4"
Internal expansion vessel (L)	8 L	8 L	8 L	8 L	8 L	8 L	8 L
Maximum water pressure (bar)	3 Bar	3 Bar	3 Bar	3 Bar	3 Bar	3 Bar	3 Bar
Refrigerant	R290	R290	R290	R290	R290	R290	R290
Volume (kg)	0.7 kg	0.7 kg	1.1 kg	1.25 kg	1.25 kg	1.25 kg	1.25 kg
Weight (kg net/kg gross)	94/114	94/114	121.5/143.5	139.5/161.5	139.5/161.5	141.5/163.5	141.5/163.5

Seasonal Coefficient of Performance (SCOP) at 35°C:

	4kW	6kW	8kW	11kW	13kW	11kWφ	13kWφ
SCOP 35°C	5.34	5.22	5.2	4.77	4.7	4.77	4.70
35°C maximum output#							
A-5°C W+35°C	5.91	6.63	9.72	11.82	14.83	11.82	14.83
A0°C W+35°C	6.28	7.22	10.33	13.14	16.13	13.14	16.13
A+7°C W+35°C	6.86	7.70	11.05	14.72	17.57	14.72	17.57
35°C nominal output†							
A-5°C W+35°C	4.12	5.98	8.10	10.37	11.94	10.37	11.94
A0°C W+35°C	4.29	5.91	8.15	10.97	12.54	10.97	12.54
A+7°C W+35°C	4.40	6.26	8.50	11.50	13.50	11.50	13.50



Seasonal Coefficient of Performance (SCOP) at 45°C:

	4kW	6kW	8kW	11kW	13kW	11kWφ	13kWφ
SCOP 45°C	4.40	4.35	4.34	4.09	4.06	4.09	4.06
45°C maximum output*							
A-5°C W+45°C	5.65	6.33	9.49	11.32	14.22	11.32	14.22
A0°C W+45°C	5.99	6.88	10.02	12.58	15.49	12.58	15.49
A+7°C W+45°C	6.55	7.35	10.47	14.06	16.85	14.06	16.85
45°C nominal output†							
A-5°C W+45°C	3.97	5.71	8.00	10.40	12.89	10.40	12.89
A0°C W+45°C	4.35	6.03	8.07	11.00	12.91	11.00	12.91
A+7°C W+45°C	4.40	6.30	8.23	11.50	13.50	11.50	13.50

Seasonal Coefficient of Performance (SCOP) at 55°C:

	4kW	6kW	8kW	11kW	13kW	11kWφ	13kWφ
SCOP 55°C	3.99	3.9	3.89	3.75	3.73	3.75	3.73
55°C maximum output*							
A-5°C W+55°C	5.15	5.79	8.40	11.02	12.95	11.02	12.95
A0°C W+55°C	5.68	6.57	9.16	12.14	14.64	12.14	14.64
A+7°C W+55°C	6.20	6.97	10.17	13.61	16.40	13.61	16.40
55°C nominal output†							
A-5°C W+55°C	4.28	5.44	7.29	10.30	11.50	10.30	11.50
A0°C W+55°C	4.40	5.50	7.52	10.80	12.78	10.80	12.78
A+7°C W+55°C	4.40	6.10	8.00	11.50	13.50	11.50	13.50

* 7 years enhanced parts-and-labour warranty is subject to terms and conditions - visit baxi.co.uk/terms for details

Output values tested at maximum compressor frequency

† Nominal values under test conditions EN14825:2013

Selections and sizing offered by Baxi utilise nominal values unless otherwise stated

Baxi HP60 ASHP

4 and 6kW outdoor unit

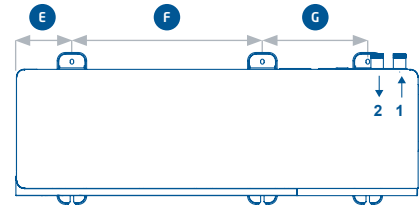
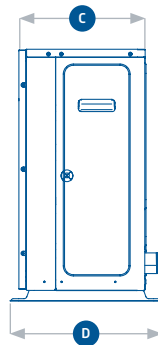
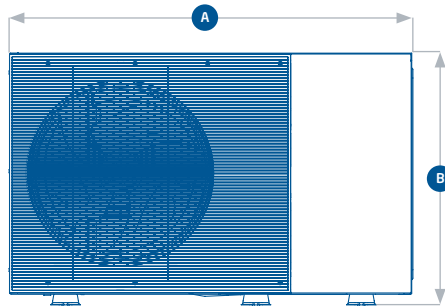

8, 11 and 13kW outdoor unit

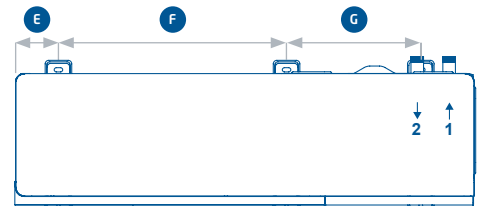
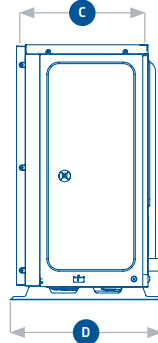
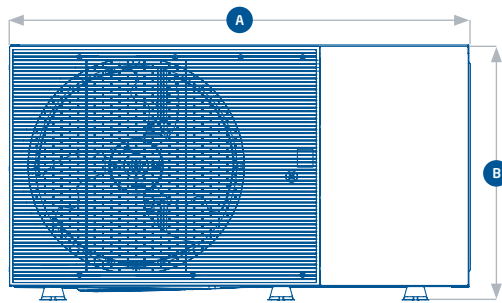

Dimensions:

Model	A (mm)	B (mm)	C (mm)	D (mm)	E (mm)	F (mm)	G (mm)
4/6kW	1302	720	371	426	124	644	379
8/13kW	1391	867	435	523	194	656	363

Compatible with:

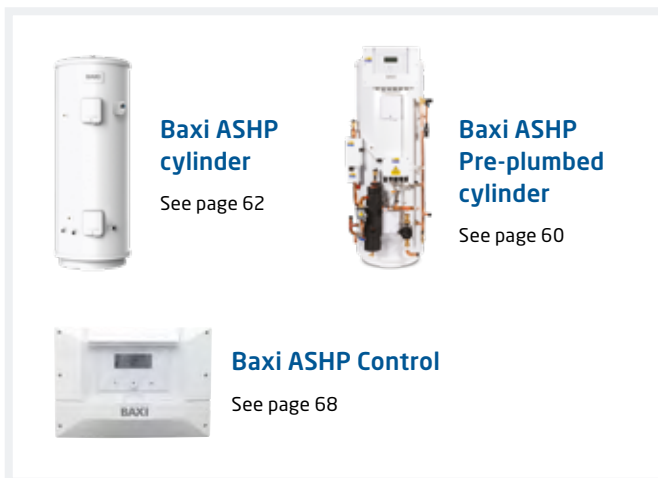

ASHP accessories:

Important installation note:

To work as intended, the Baxi HP60 Air Source Heat Pump must be installed with either a Baxi ASHP Control or a Baxi ASHP Pre-plumbed cylinder.

Product description	Product code
Baxi ASHP Control	7890025
Rubber Support For ODU 600mm (3 Pack)	7816801
1 1/4" Antifrost Caleffi valve kit	7842647
Flexible Hoses 1" Heat Pump	100001369
Baxi 24L Buffer Tank	7851676
Baxi 40L Buffer Tank	7768655
Set Back Up Elec Connect EH904	7708345
Electrical Back Up Heater 3kW	7755564
Electrical Back-Up Heater 4.5k	7755565

Please contact your Area Sales Manager for a full list of ASHP accessories.

SCAN ME



For more information visit www.baxi.co.uk/professional/products



Air Source Heat Pump commissioning

We're here to help you commission your air source heat pump installation to ensure optimum performance, efficiency and energy savings can be achieved. Our highly trained service engineers can be booked for a site visit to commission your air source heat pump and handover to your customer. We offer on-site assisted commissioning for new installations, as part of our ASHP training.



Warranty

An enhanced product warranty



Quality

Reassurance of installation and setup configuration



Performance

Longevity and optimised performance of the equipment



Find out more at [baxi.co.uk](https://www.baxi.co.uk)

Air source heat pumps

Baxi HP40 ASHP

The mid temperature Baxi HP40 Monobloc Air Source Heat Pump will deliver reliable, energy-efficient performance. Available individually or with our Baxi Air Source Heat Pump cylinders, we have everything you need to provide a complete solution.



Up to 5 years enhanced warranty*



4-13kW outputs - all single phases with optional triple phase for larger outputs



Up to 65°C flow temperature



Excellent SCOP: up to 5.03

Technical information	4kW	5kW	7kW	8kW	11kW	13kW	11kWφ	13kWφ
Product code	7830576	7830575	7830574	7830573	7830572	7830571	7830570	7830568
Min/max operating range (°C)	-25/+35	-25/+35	-25/+35	-25/+35	-25/+35	-25/+35	-25/+35	-25/+35
Sound pressure level dB(A) @1m	45.0	47.5	48.0	50.5	53.0	57.5	53.5	58.0
Sound power level dB(A) (EN12102-1)	55	58	59	60	65	68	65	68
ErP @ 35°C	A+++	A+++	A+++	A+++	A+++	A+++	A+++	A+++
ErP @ 55°C	A++	A++	A++	A++	A++	A++	A++	A++
Power supply (V/Ph/Hz)	220-240/1/50	220-240/1/50	220-240/1/50	220-240/1/50	220-240/1/50	220-240/1/50	380-415/3/50	380-415/3/50
MCA (A)	12	14	16	17	25	27	10	12
TOCA (A)	18	18	19	19	30	30	14	14
MFA (A)	25	25	25	25	35	35	16	16
Flow/return connections	G 1"	G 1"	G 1 1/4"	G 1 1/4"	G 1 1/4"	G 1 1/4"	G 1 1/4"	G 1 1/4"
Internal expansion vessel (L)	8	8	8	8	8	8	8	8
Maximum water pressure (bar)	3	3	3	3	3	3	3	3
Refrigerant	R32	R32	R32	R32	R32	R32	R32	R32
Volume (kg)	1.4	1.4	1.4	1.4	1.75	1.75	1.75	1.75
Weight (kg net/kg gross)	86/107	86/107	105/132	105/132	129/155	129/155	144/172	144/172

Seasonal Coefficient of Performance (SCOP) at 35°C:

	4kW	5kW	7kW	8kW	11kW	13kW	11kWφ	13kWφ
SCOP 35°C	4.66	4.77	5.03	5.03	4.67	4.49	4.67	4.49
35°C maximum output#								
A-5°C W+35°C	5.02	6.14	7.69	8.80	11.3	14.0	11.3	14.0
A0°C W+35°C	5.10	6.35	8.49	9.56	12.0	14.3	12.0	14.3
A+7°C W+35°C	6.26	7.41	9.11	10.3	14.6	16.8	14.6	16.8
35°C nominal output†								
A-5°C W+35°C	4.37	5.26	6.69	7.66	9.05	11.2	9.05	11.2
A0°C W+35°C	4.60	5.74	7.67	8.63	9.19	10.9	9.19	10.9
A+7°C W+35°C	4.20	6.35	8.40	10.0	12.1	15.9	12.1	15.9



Seasonal Coefficient of Performance (SCOP) at 45°C:

	4kW	5kW	7kW	8kW	11kW	13kW	11kW ϕ	13kW ϕ
SCOP 45°C	3.93	4.06	4.11	4.19	4.01	3.88	4.01	3.88
45°C maximum output[#]								
A-5°C W+45°C	4.63	5.84	7.44	8.18	10.9	13.4	10.9	13.4
A0°C W+45°C	5.04	6.85	8.09	8.89	12.3	14.1	12.3	14.1
A+7°C W+45°C	5.96	7.13	8.98	10.3	14.5	16.6	14.5	16.6
45°C nominal output[†]								
A-5°C W+45°C	4.10	5.10	6.49	7.13	8.78	10.7	8.78	10.7
A0°C W+45°C	4.46	6.06	7.16	7.87	9.43	10.8	9.43	10.8
A+7°C W+45°C	4.30	6.30	8.10	10.0	12.3	16.0	12.3	16.0

Seasonal Coefficient of Performance (SCOP) at 55°C:

	4kW	5kW	7kW	8kW	11kW	13kW	11kW ϕ	13kW ϕ
SCOP 55°C	3.19	3.39	3.23	3.37	3.34	3.30	3.34	3.30
55°C maximum output[#]								
A-5°C W+55°C	4.41	5.31	7.35	7.53	10.6	12.6	10.6	12.6
A0°C W+55°C	5.13	5.42	8.11	8.18	10.8	12.8	10.8	12.8
A+7°C W+55°C	5.74	6.90	8.43	9.72	13.9	16.2	13.9	16.2
55°C nominal output[†]								
A-5°C W+55°C	3.94	4.28	5.56	6.49	8.36	9.98	8.36	9.98
A0°C W+55°C	4.43	4.75	6.33	7.30	7.93	9.77	7.93	9.77
A+7°C W+55°C	4.40	6.00	7.50	9.50	11.9	16.0	11.9	16.0

* 5 years enhanced parts-and-labour warranty is subject to terms and conditions - visit baxi.co.uk/terms for details

[#] Output values tested at maximum compressor frequency

[†] Nominal values under test conditions EN14825:2013

Selections and sizing offered by Baxi utilise nominal values unless otherwise stated

Air source heat pumps

Baxi HP40 ASHP

4/5kW outdoor unit

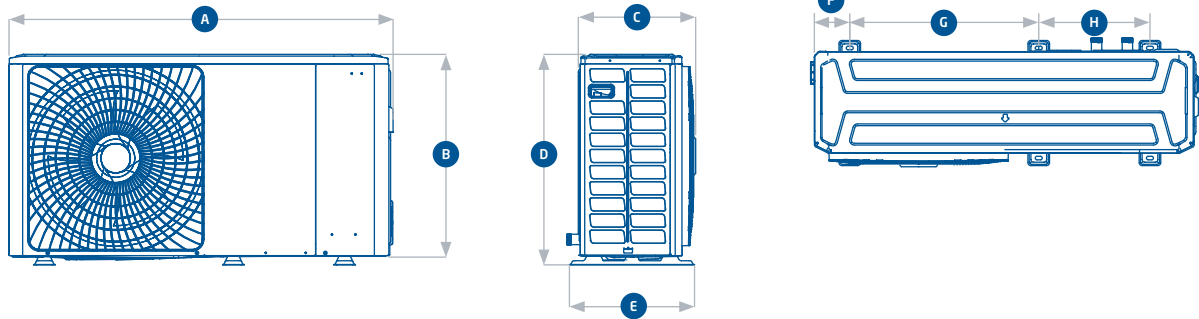

7/8/11/13kW outdoor unit

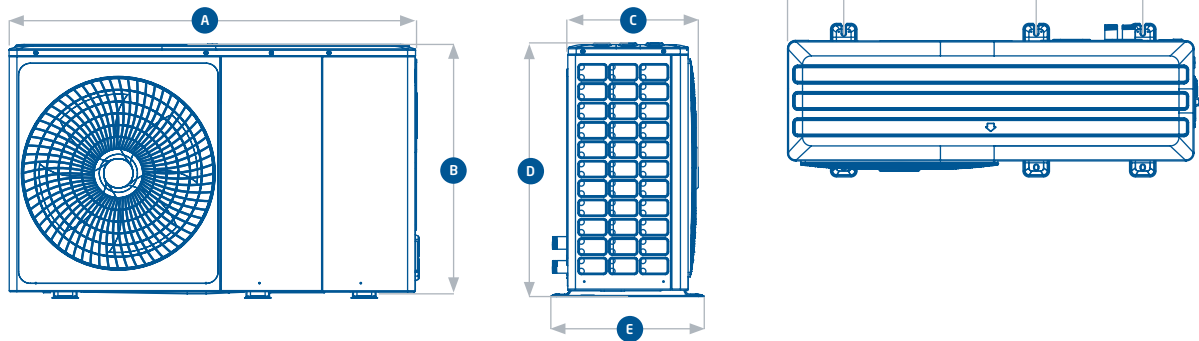

Dimensions:

Model	A (mm)	B (mm)	C (mm)	D (mm)	E (mm)	F (mm)	G (mm)	H (mm)
4/5kW	1309	700	400	717	426	121	644	379
7/8/11/13kW	1388	850	448	864	523	191	656	363

Compatible with:

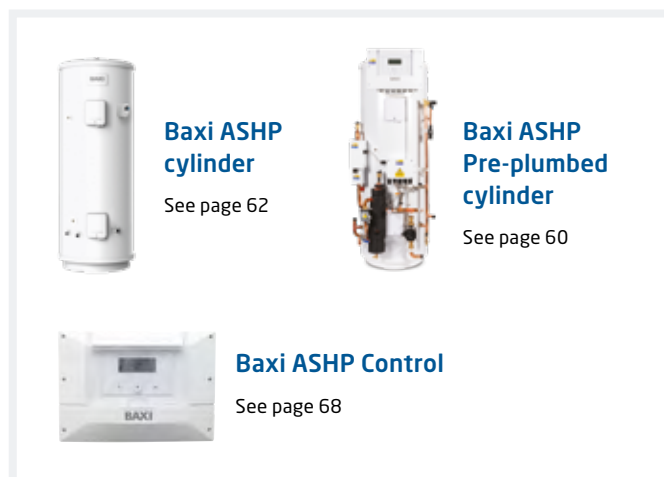

ASHP accessories:

Product description	Product code
Magnetic Filter	7768650
Temperature Probe Extension 20m	7859015
Rubber support for ODU 600mm (3 Pack)	7816801
Baxi 24L Buffer Tank	7851676
Baxi 40L Buffer Tank	7768655
Electrical Back Up Heater 3kW	7755564
Electrical Back-Up Heater 4.5kW	7755565

SCAN ME



For more information visit www.baxi.co.uk/professional/products

We're here to support you

Our UK-wide network of Area Sales Managers is always on-hand to help you.



Get all the information you need about our range of heating and hot water solutions



Keep up to date with our latest products and heating industry legislation



Find out about our product training and specialist courses – including three-day fault-finding, system wiring and controls, and much more



To find out where and when your nearest trade awareness morning is being held, visit baxi.co.uk

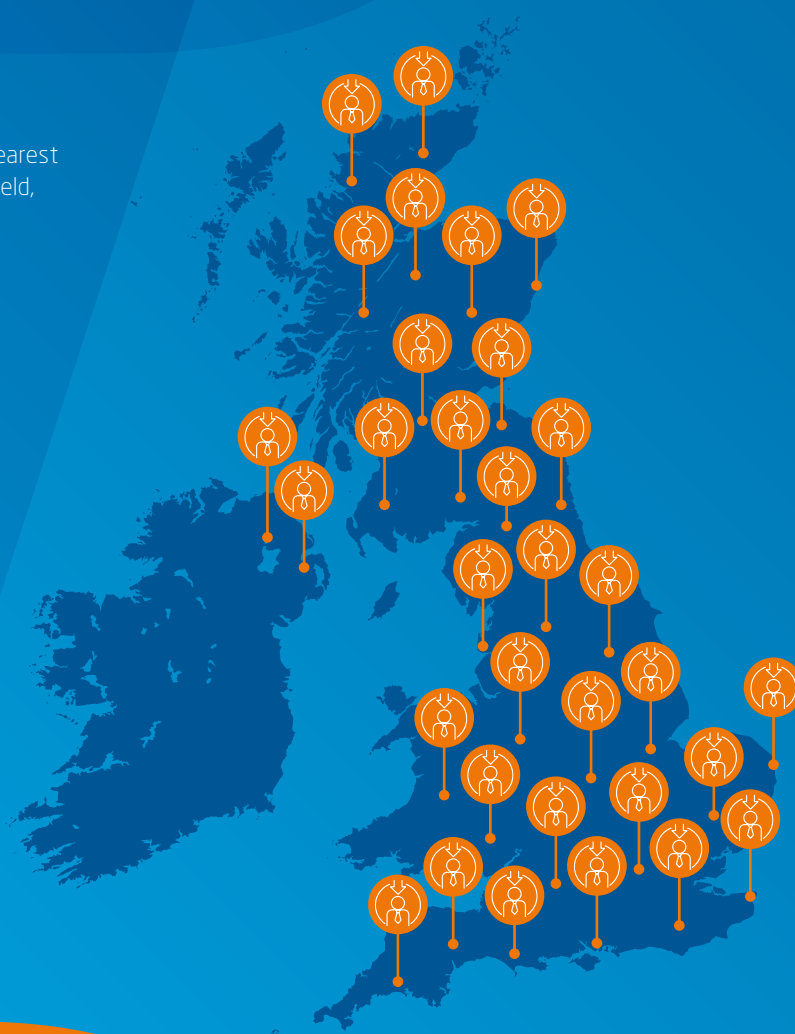

Air source heat pumps

Baxi ASHP Pre-plumbed cylinder

Designed to work seamlessly with Baxi air source heat pumps, our pre-plumbed cylinder makes installation quicker and easier without compromising performance.

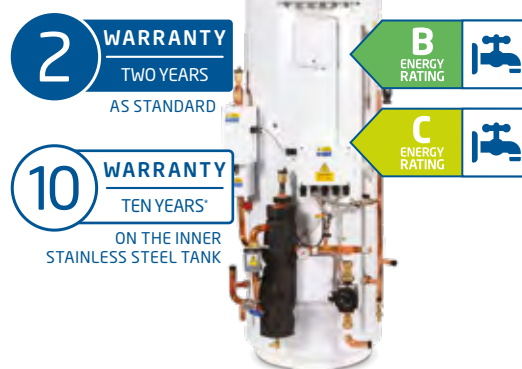

**170, 210,
250, 300
litre volumes**



**Built-in
controller with
Bluetooth
connectivity**



**Pre-plumbed and
pre-wired for
quicker, easier
installation**



**Corrosion
resistant
stainless steel
build**

Technical information	170	210	250	300
Product Code	7853985	7853986	7853987	7853988
Nominal capacity (ltrs)	170	210	250	300
Insulation Thickness (mm)	60	60	60	60
Insulation Material	PU	PU	PU	PU
Coil rating kW @15l/min at 80°C - +/- 2°C	33	33	37	38
Coil surface area (m ²)	2	2	3	3
Coil Heat-up times @15l/min, 80°C primary flow, from 10°C to 60°C (mins)	18.7	21.4	22.9	27.2
External expansion sizes (L)	24	24	24	24
Immersion Element rating kW @240V	3	3	3	3
T&P pressure setting (bar)	10	10	10	10
T&P temperature setting (°C)	90	90	90	90
Pressure reducing valve (bar)	3.5	3.5	3.5	3.5
Pressure (expansion) relief setting (bar)	8	8	8	8
Standing heat loss per day (kWh/24H)	1.38	1.64	1.86	2.02
Standing heat loss per year (kWh/year)	504	599	679	737
Max flow rate (l/min)	76	76	76	76
Global warming potential	3.1	3.1	3.1	3.1
Connections type	28mm H.P. Flow/Return Heating 28mm 22mm DHW/3/4" BSP Male	28mm H.P. Flow/Return Heating 28mm 22mm DHW/3/4" BSP Male	28mm H.P. Flow/Return Heating 28mm 22mm DHW/3/4" BSP Male	28mm H.P. Flow/Return Heating 28mm 22mm DHW/3/4" BSP Male
Electrical heater bosses inc blanks	1 x G1 3/4"	2 x G1 3/4"	2 x G1 3/4"	2 x G1 3/4"
Heat up times based on max immersion input(mins)	195	67	67	67
Cylinder material	Duplex Stainless Steel	Duplex Stainless Steel	Duplex Stainless Steel	Duplex Stainless Steel
The water heating energy efficiency class	B	B	C	C
Storage V in litres @ 3 bar	167	209	246	287
IPX Rating	X1b	X1b	X1b	X1b
Immersion heater material	Incoloy	Incoloy	Incoloy	Incoloy



Dimensions:

Product dimensions	170	210	250	300
Height (mm)	1,280	1,516	1,767	2,082
Width (mm)	700	700	700	700
Diameter (mm)	579	579	579	579
Weight empty (kg)	61	68	74	83
Weight (kg)	228	277	320	370

Compatible with:



Baxi HP60 ASHP

See page 52



Baxi HP40 ASHP

See page 56

For more information visit www.baxi.co.uk/professional/products

SCAN ME



Air source heat pumps

Baxi ASHP cylinder

The Baxi ASHP cylinder powers rapid-heating. An efficient cylinder with high surface area heat exchanger and built-in back-up immersion heaters designed specifically for Baxi Air Source Heat Pumps.

2 WARRANTY
TWO YEARS
AS STANDARD

10 WARRANTY
TEN YEARS*
ON THE INNER
STAINLESS STEEL TANK

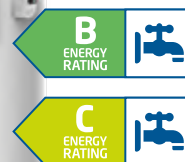

210, 250 and 300 litre volumes



Corrosion resistant stainless steel build



Delivers up to 76 litres per minute of hot water

Technical information	210	250	300
Product code	7837416	7837491	7837562
Nominal capacity	210	250	300
Coil rating (@15l/min at 80°C)	33.2	36.8	35.5
Heat up times (mins)	21.5	22.8	27.8
Heat loss (kWh/24h)	1.5	1.78	2.05
ErP rating	C	C	C
Mixed water at 40°C V40 in litres	191	238	286
Weight (kg)	60	69	74
Max mains pressure	1.6MPa (16 bar)		
Max design pressure	0.6MPa (6 bar)		
Operating pressure	0.35MPa (3.5 bar)		
Max primary pressure	0.3MPa (3 bar)		
Expansion relief valve setting	0.6MPa (6 bar)		
T&P valve setting	1MPa (10 bar)		
Immersion heater rating (AC supply only)	3kW @ 240V, 2.8kW @ 230V		

Dimensions:

Product dimensions	210	250	300
Height (mm)	1,524	1,837	2,088
Width (mm)	579	579	579
Depth (mm)	652	652	652

Compatible with:



Baxi HP40 ASHP

See page 56



Baxi HP60 ASHP

See page 52

For more information visit www.baxi.co.uk/professional/products

SCAN ME



Quality. Safe. Reliable. Trustworthy. Tested.



All Baxi Genuine Parts meet our rigorous quality control standards



Approved for use with all our products



Designed to work better and for longer, cutting down on the unnecessary cost of buying replacement parts



Avoid the problems that can occur when using cheap, counterfeit parts



Fully-compliant with Gas Safe Regulations, protecting installers and consumers



Identify the parts you need with **PartsArena**



Find a **stockist** near you





Complementary products

Baxi's suite of accessories are designed to complete a residential heating system. Each accessory is easy to install, whatever its function – whether boosting performance, improving user experience, aligning with legislative requirements or reducing costs.

In this section

- Baxi uSense 2 **66**
- Baxi RF Thermostat (Twin Channel) **67**
- Baxi OpenTherm RF Thermostat (Single Channel) **67**
- Baxi ASHP Control **68**
- Baxi Offset Flue Adapter **68**
- Baxi Easy-Flue **69**
- Multifit IFOS **69**
- Optional controls, accessories and compatibility **70**
- Flue solutions **72**

Did you know?

We have a range of efficiency boosting wireless controls, visit [baxi.co.uk/accessories](https://www.baxi.co.uk/accessories)

Complementary products

Baxi uSense 2

Our smart room thermostat allows users to control their central heating on the move via the My Baxi App, to maximise comfort and efficiency.



Monitors energy usage



Voice activation control via Alexa or Siri



Daily scheduled heating and holiday mode

Technical information

Room temperature measurement range (°C)

5-60

Maximum temperature deviation at 20 degrees (°C)

0.3

Maximum room control overshoot after pre-heating (°C)

1

Temperature variation (°C)

+/- 0.25

Outside temperature (°C)

Refer to appliance documentation

Temperature control area

10-30

Ambient conditions

Storage temperature (°C)

25-70

Relative humidity (°C)

5-95*

Operating conditions (°C)

0-60

Power supply

R-Bus connection voltage (V)

24 ± 5%

Maximum power consumption (W)

1.5

Electrical connection

Maximum cable length for dedicated room unit R-Bus (m)

50

Dimensions:

Maximum dimensions

mm

A Width

120

B Height

90

C Depth

27

* Condensation is not allowed

Compatible with:



Baxi 400, 600 and 800 Combi 2

See pages 6-11

Amptec S

See page 24



Baxi HP40 ASHP

See page 56

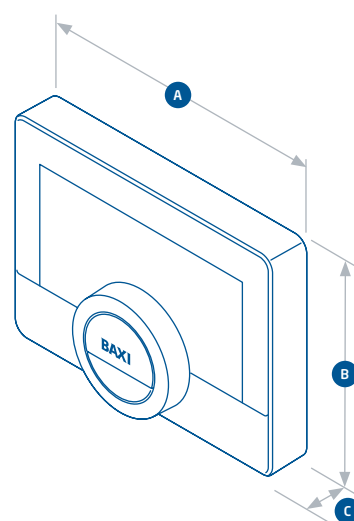

For **product codes**, please refer to the compatibility table on page 70

For more information on our comprehensive range of accessories, visit www.baxi.co.uk/accessories

SCAN ME



Complementary products

Baxi OpenTherm RF Thermostat (Single Channel)

A simple, wireless solution for flexible heating control. The Baxi OpenTherm RF Thermostat is easy to use and can manage up to six heating zones when paired with additional units – perfect for tailored comfort throughout the home.



Programmable for one heating zone



OpenTherm for maximum performance and efficiency



Central heating boost function

Baxi RF Thermostat (Twin Channel)

Reliable, wireless and easy to use, the Baxi RF Programmer gives you simple control of both heating and hot water. With twin channel programming and a straightforward interface, it's a flexible solution for everyday comfort.



Twin channel control



Wireless Connectivity



7 days, 5/2 days or 24 hour scheduling

For **product codes**, please refer to the compatibility table on page 70

For more information on our comprehensive range of accessories, visit www.baxi.co.uk/accessories

SCAN ME



Complementary products

Baxi ASHP Control

Available on its own or pre-fitted to the Baxi ASHP Pre-plumbed cylinder, the Baxi ASHP Control manages heat pump performance and helps lower running costs in hybrid setups.

Available Autumn 2025



Optimises ASHP performance and efficiency



Simplified wiring



Easy to commission



Supports energy management

Compatible with:



Baxi HP60 ASHP

See page 52



Baxi HP40 ASHP

See page 56

Baxi Offset Flue Adapter

Designed for flexibility, our offset flue adapter is the smart way to replace a standard offset flue boiler with a compact centre flue model. Faster installs, cleaner finish, less hassle.



Perfect for replacing standard offset flue boilers



Designed for Baxi & Main compact centre flue models



Saves you time and reduces installation hassle

For **product codes**, please refer to the compatibility table on page 70

For more information on our comprehensive range of accessories, visit www.baxi.co.uk/accessories

SCAN ME



Complementary products

Baxi Easy-Flue

Our internal fit telescopic flue can be installed either at height or at ground level, quickly and safely by one person from inside the property, reducing the need for ladders.



Built in flue elbow fits directly onto the top of the boiler



60/100 and oversize weather seal provided as standard



Short (300mm-470mm) and long (420mm-690mm) options available

Complementary products

Multifit IFOS

Our In Flue Outdoor Sensors meet weather compensation requirements for Boiler Plus. Options available for every Combi and System boiler.



Accurate temperature sensing



Quick and easy to install



Suitable for both horizontal and vertical flues

Baxi Easy-Flue and Multifit IFOS compatible with:



Baxi 400, 600 and 800 Combi 2

See pages 6-11



Baxi 600 and 800 System 2

See pages 12-15

For **product codes**, please refer to the compatibility table on page 70















For more information on our comprehensive range of accessories, visit www.baxi.co.uk/accessories

SCAN ME



Complementary products

Optional controls, accessories and compatibility

Product description	Product code	Baxi 800 Combi 2 600 Combi 2 400 Combi 2.1	Baxi 600 System 2 800 System 2	Baxi 800 Heat 600 Heat 400 Heat	Baxi HP40 ASHP	Baxi H60 ASHP	Baxi Amptec S
 Baxi uSense 2	7775937	●			●	●	●
 Baxi OpenTherm RF Thermostat (Single Channel)	7896911	●			●	●	●
 Baxi RF Thermostat (Twin Channel)	7896912		●	●	●	●	●
 Baxi ASHP Control	7890025				●	●	
 Multifit IFOS -W Combi	7724181	●					
 Multifit IFOS - System	7729979		●				
 Multifit IFOS - Extension	7724260	●	●				
 Multifit IFOS - Ridge Tile	7729943	●	●				
 Multifit Filling Loop Kit	248221	●	●	●			
 Multifit Easy-Fill 2	7783329	●					
 Multifit Pre-plumb Jig 2	7818249	●	●				
 Multifit Rear Pipework Kit 2	7823084	●	●				
 Multifit External Boiler Discharge Pump (PRV and condensate)	720648301	●	●	●			
 5 Core Cable Combi/System 2	7887013	●	●				

BAXI

Bend it like Baxi

The **new** Baxi offset flue adapter is the smart way to replace a standard offset flue boiler with a compact centre flue model. Faster installs, cleaner finish, less hassle.

- Fits Baxi & Main compact combi & system boilers
- Saves time
- Looks professional every time



Saves you time and
reduces installation hassle



Neater finish,
happier customers

Flue solutions

Our Multifit flue kits now feature secure positive screw fixings for all connections, ensuring reliable installation every time. Designed to make your job easier, they come in a variety of lengths to minimise on-site cutting. With a choice of terminal colours to seamlessly match existing rainwater systems and UV-stable construction for long-lasting durability, our flues combine practicality with premium performance.

Key considerations:

	Flue type	Group A (60/100mm)
Maximum permissible equivalent flue lengths for Baxi Combi, System boilers	Horizontal concentric Vertical concentric	10m 10m
Maximum permissible equivalent flue lengths for Baxi Heat only boilers	Horizontal concentric Vertical concentric	6m 6m
Where in-line bends are required in a flue system, the overall length must be reduced by the following amounts	Concentric pipes	135° bend (0.5m bend reduction) 93° bend (1m bend reduction)

Horizontal concentric flues Ø 60/100mm:

Item	Description (Multifit flue system - group A)	Colour	Specification	Product code
1	Horizontal telescopic flue including low profile elbow and fixing screws	White pipe/ white terminal	315mm - 500mm	720599401
2	Horizontal telescopic flue including low profile elbow and fixing screws	White pipe/ black terminal	315mm - 500mm	720598701
3	Baxi Easy-Flue - short	White pipe/ black terminal	300mm - 470mm	7778296
3b	Baxi Easy-Flue - long	White pipe/ black terminal	420mm - 690mm	7778299
4	Standard horizontal flue including low profile elbow and fixing screws	White pipe/ black terminal	685mm	7222019
4b	1.8m high rise horizontal terminal 60/100	White pipe/ black terminal	1,800mm	7778067
4c	Horizontal flue A/S			7743932
5	Telescopic rear flue (in case)	White pipe/ black terminal	220mm - 345mm	7210434
6	Flue terminal deflector	Black		5111068
7	1m flue extension including fixing screws	White	1,000mm	720648801
7b	2m high rise extension including fixing screws	White	2,000mm	7778230
8	0.5m flue extension including fixing screws	White	500mm	720643001
9	0.25m flue extension including fixing screws	White	250mm	720643101
10	93° flue bend including fixing screws	White	93°	720648401
11	135° flue bend including fixing screws	White	135°	720648501
12	135° flue bend including fixing screws (pair)	White	135°	720647901
12b	Baxi Offset Flue Adapter	White	100mm	7778725
13	Stainless steel terminal guard - Ø 60/100	Stainless steel		720627901
14	Pipe support bracket	White	100mm	5111080

Plume displacement kits Ø 60/100mm:

Item	Description (Multifit flue system - group A)	Colour	Specification	Product code
13	Stainless steel PDK guard - air intake	Stainless steel		720644601
15	Plume displacement terminal kit for telescopic flue including 1m extension and brackets	White		720627001
15b	Plume displacement kit with 1m extension (for Baxi Easy-Flue)	White pipe/ black terminal		7845831
16	Plume displacement kit extension and brackets	White	1,000mm	720643401
17	Plume displacement kit bend	White	93°	5121369
18	Plume displacement terminal kit for telescopic flue including 1m extension and brackets	Black		720622901
19	Plume displacement kit extension and brackets	Black	1,000mm	720643301
20	Plume displacement kit bend	Black	93°	720648701
21	Plume displacement kit bend (pair)	Black	135°	720648601
22	Plume displacement terminal kit including 1m extension and brackets	White		7225717
22b	Plume displacement terminal kit including 1m extension and brackets	Black		7225716
23	High rise plume displacement kit	Black		7778272
23b	Plume displacement terminal kit (Diffuser)	Black		7213532
24	Under balcony eaves flue kit	White	135°	7211039
25	Under balcony eaves flue kit	Black	135°	7211041

Vertical concentric flues Ø 60/100mm:

Item	Description (Multifit flue system - group A)	Colour	Specification	Product code
26	Vertical flue terminal	Black		5118576
27	Vertical ridge flue terminal	Brown		720647101
28	Roof cover plate			246143
7	1m flue extension including fixing screws	White	1,000mm	720648801
29	0.25m flue extension including fixing screws	White	250mm	720643101
29b	0.5m flue extension including fixing screws			720643001
10	93° flue bend including fixing screws	White	93°	720648401
11	135° flue bend including fixing screws	White	135°	720648501
12	135° flue bend (pair) including fixing screws	White	135°	720647901
30	Pitched roof flashing		25°/50°	5122151
31	Flat roof flashing			246144
15	Pipe support brackets	White	100mm flue pipes	5111080

Flue solutions



For more information on our flue range, visit www.baxi.co.uk/professional/products/flues-and-accessories

SCAN ME



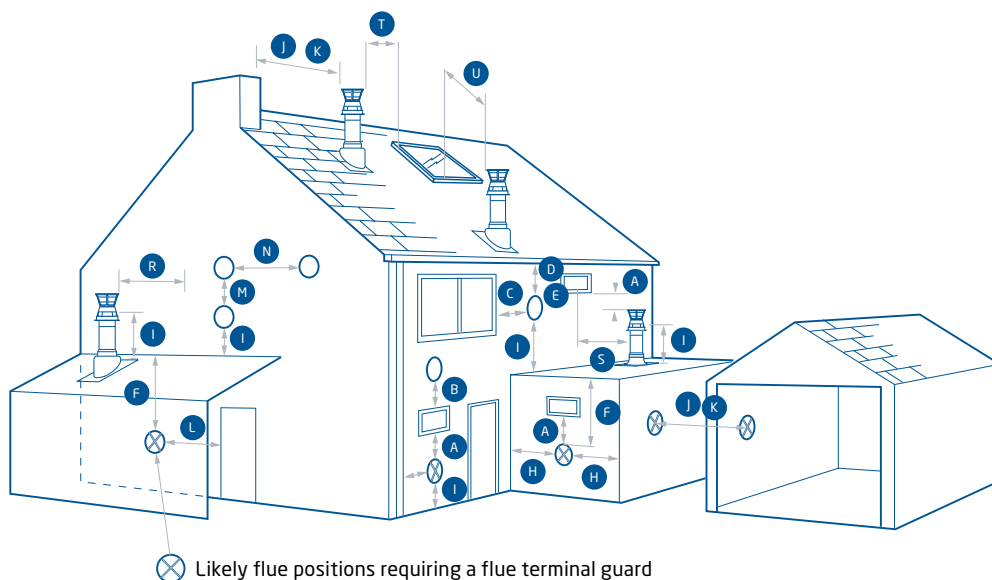

⊗ Likely flue positions requiring a flue terminal guard

Terminal position with minimum distance (mm)

A ¹	Directly below an opening, air brick, opening windows etc	300
B ¹	Above an opening, air brick, opening window etc	300
C ¹	Horizontally to an opening, air brick, opening window etc	300
D ²	Below gutters, soil pipes or drain pipes	25
E ²	Below eaves	25
F ²	Below balconies or car port roof	25
G ²	From a vertical drain pipe or soil pipe	25
H ²	From an internal or external corner	25
I	Above ground, roof or balcony level	300
J	From a surface or boundary line facing a terminal	600

Terminal position with minimum distance (mm)

K	From a terminal facing a terminal (Horizontal flue)	1,200
K	From a terminal facing a terminal (Vertical flue)	600
L	From an opening in a carport (e.g. door, window) into the dwelling	1,200
M	Vertically from a terminal on the same wall	1,500
N	Horizontally from a terminal on the same wall	300
R	From adjacent wall to flue (vertical only)	300
S	From an adjacent opening window (vertical only)	1,000
T	Adjacent to windows or openings on pitched and flat roofs	600
U	Below windows or openings on pitched roofs	2,000

- In addition, the terminal should be no nearer than 150mm to an opening in the building fabric formed for the purpose of accommodating a built-in element such as a window frame.
- Only ONE 25mm clearance is allowed per installation. If one of the dimensions D, E, F, G or H is 25mm then the remainder MUST be as B.S.5440-1.

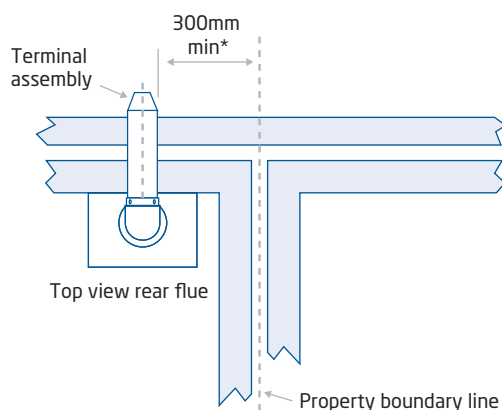

NOTE: The distance from a fanned draught appliance terminal installed parallel to a boundary may not be less than 300mm in accordance with the diagram.

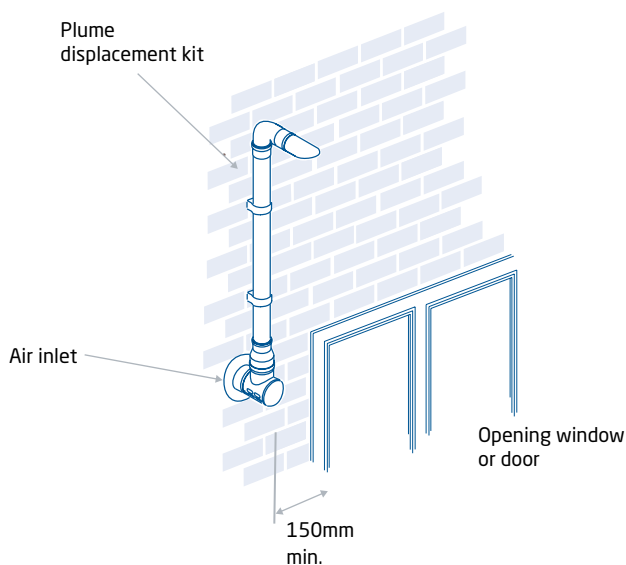

IMPORTANT: If fitting a Plume Displacement Flue Kit, the air inlet must be a minimum of 150mm from any opening windows or doors.

Get in touch

Call: **0344 871 1540**

Email: **info@baxi.co.uk**

Visit: **baxi.co.uk**

Follow us:



Baxi
Brooks House
Coventry Road
Warwick CV34 4LL

Baxi Heating UK Limited is registered in England and Wales with company number 03879156 and registered office address Brooks House, Coventry Road, Warwick, CV34 4LL. VAT registration number is 604665837. Information is correct as at time of publication (November 2025) - ref no. 11871-1125-V1

BAXI

remeha

megaflo

ANDREWS
WATER HEATERS

HEATRAESADIA

MAIN

Residential and commercial
heating and hot water solutions