









8mm DOUBLE DOOR OFFSET QUADRANT

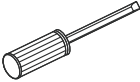
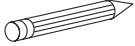
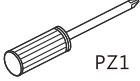

General Information

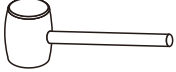
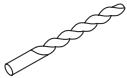
Please inspect this product upon delivery. Any missing parts or manufacturing defects must be reported immediately to the supplier. Damage or defects reported later will not be accepted. TAKE CARE WHEN HANDLING GLASS PARTS-AVOID HEAVY CONTACT BETWEEN THE GLASS EDGES AND ANY HARD SURFACE. Glass breakage claims will not be accepted after the product has been unpacked.

TOOLS REQUIRED

DESCRIPTION	PART IMAGE	DESCRIPTION	PART IMAGE
Tape measure		Drill	
Spirit level		Flat-head Screwdriver	
Pencil		Cross head Screwdriver	 PZ1
Ø6mm Drill bit		Mallet	
Ø3mm Drill bit		Silicone Sealant	
Ø4 Allen Key		Ø2 Allen Key	

 This product is heavy and may require two people to install.

ASSEMBLY INSTRUCTIONS - DRAWING

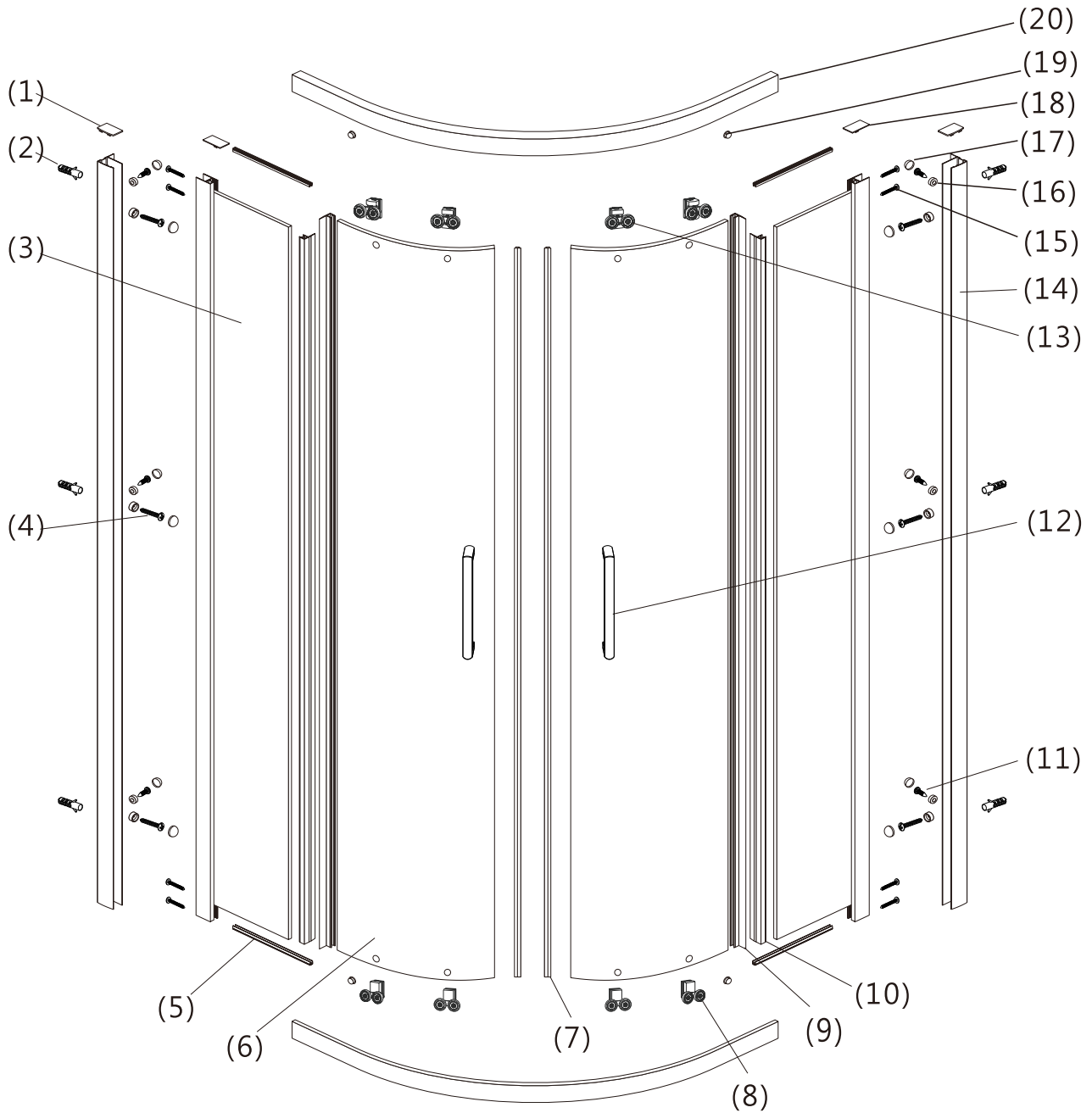

- (1) 2x Wall Profile Cover Caps
- (2) 6x Wall Plugs
- (3) 2x Fixed Panels
- (4) 6x Screws 4x30
- (5) 4x Fixed Panel Seals
- (6) 2x Moving Panels
- (7) 2x Magnet Seals
- (8) 4x Bottom Rollers
- (9) 2x Moving Panel Seals
- (10) 2x Fixed Panel Seals

- (11) 6x Screws 4x12
- (12) 2x Handles (Supplied Separately)
- (13) 4x Top Rollers
- (14) 2x Wall Profiles
- (15) 8x Screws 4x40
- (16) 12x Screw Cover Clips
- (17) 12x Screw Cover Caps
- (18) 2x Upright Profile Cover Caps
- (19) 4x Glass Clamp Screw Cover Caps
- (20) 2x Top and Bottom Profiles

STEP 1

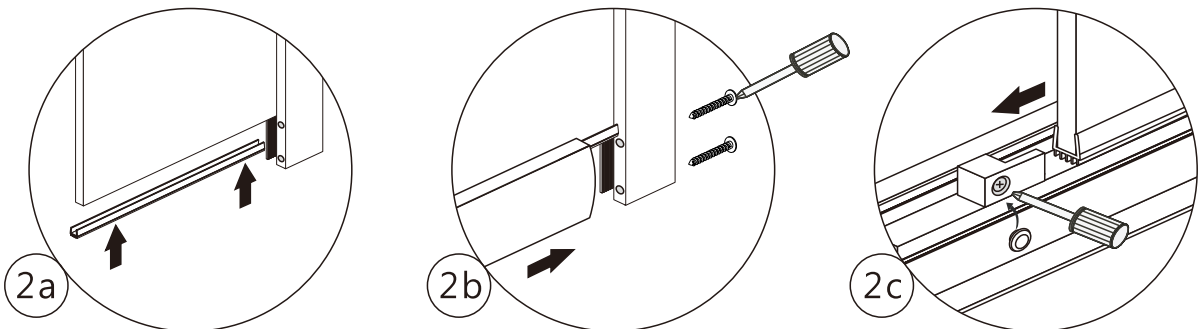
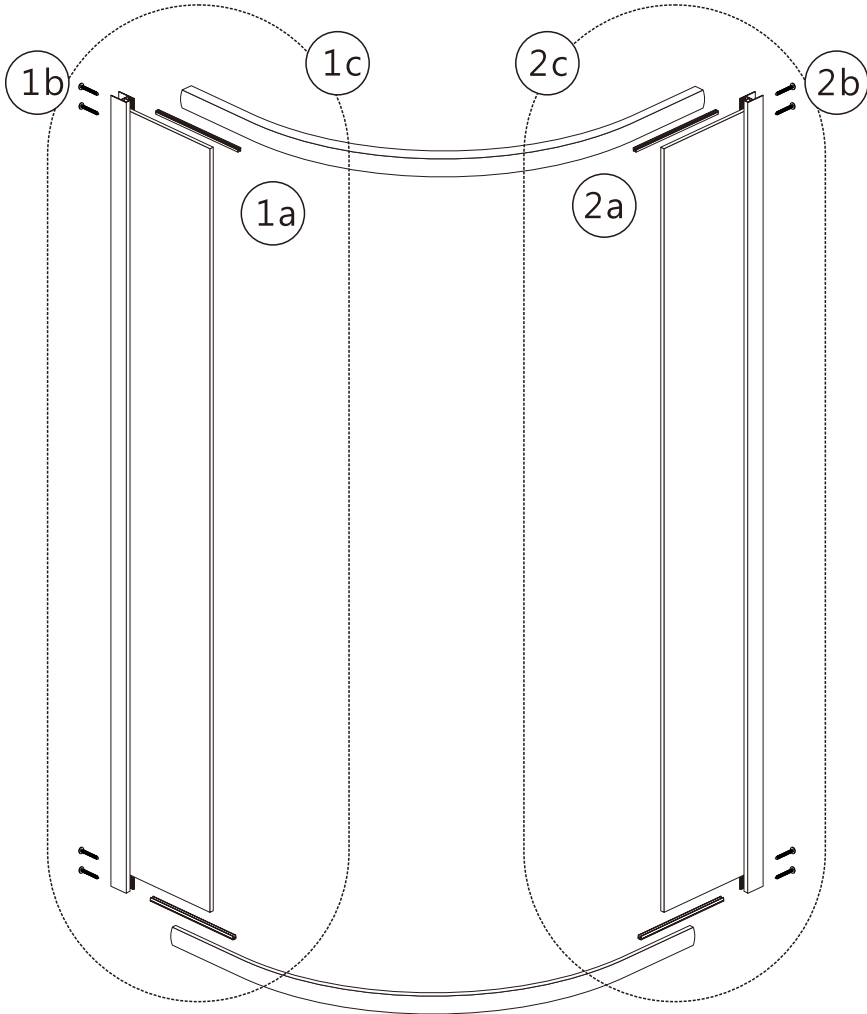
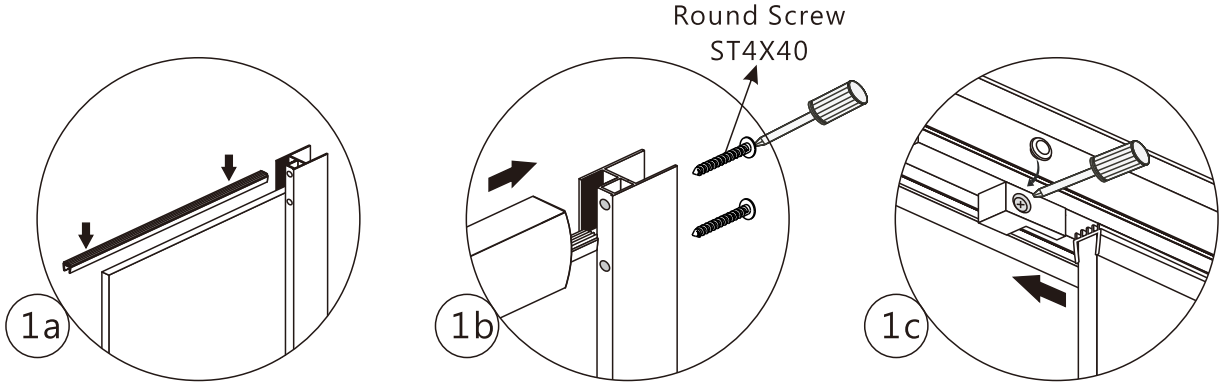

STEP 2 SLIDE THE WALL PROFILES ON TO THE FRAME THEN LIFT WHOLE UNIT ON TO THE TRAY, WHEN DESIRED POSITION IS REACHED USING THE AVAILABLE WALL PROFILE ADJUSTMENT, MARK THE WALLS AND LIFT UNIT OFF THE TRAY

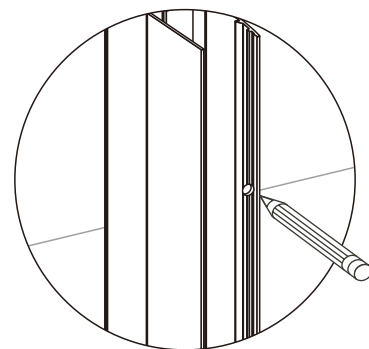
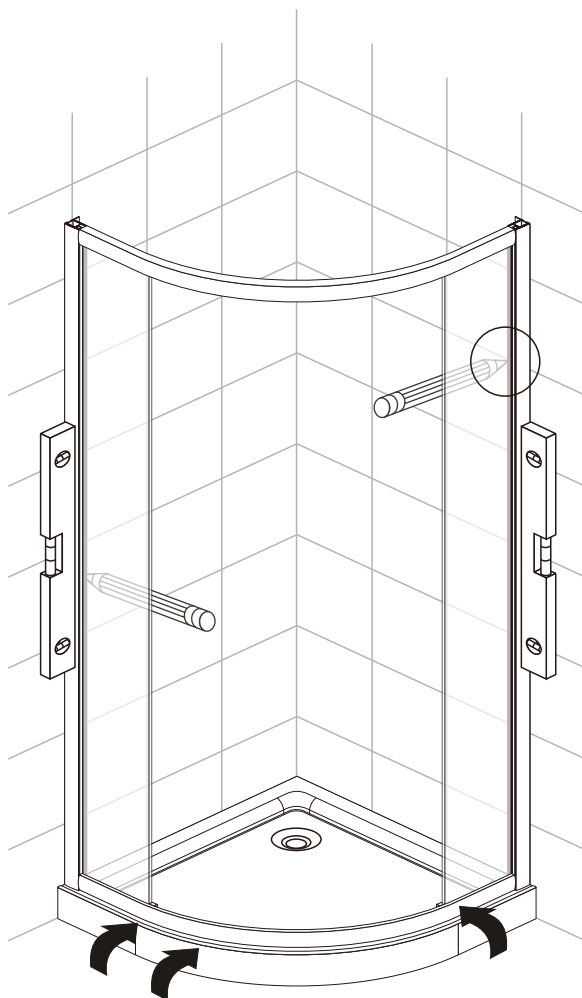
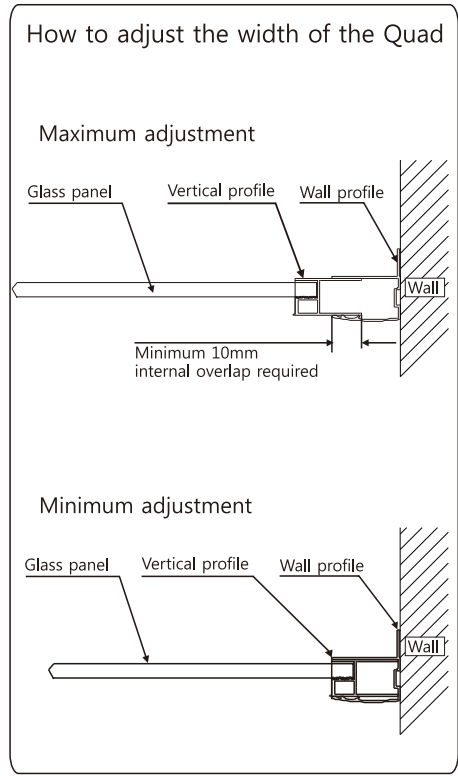
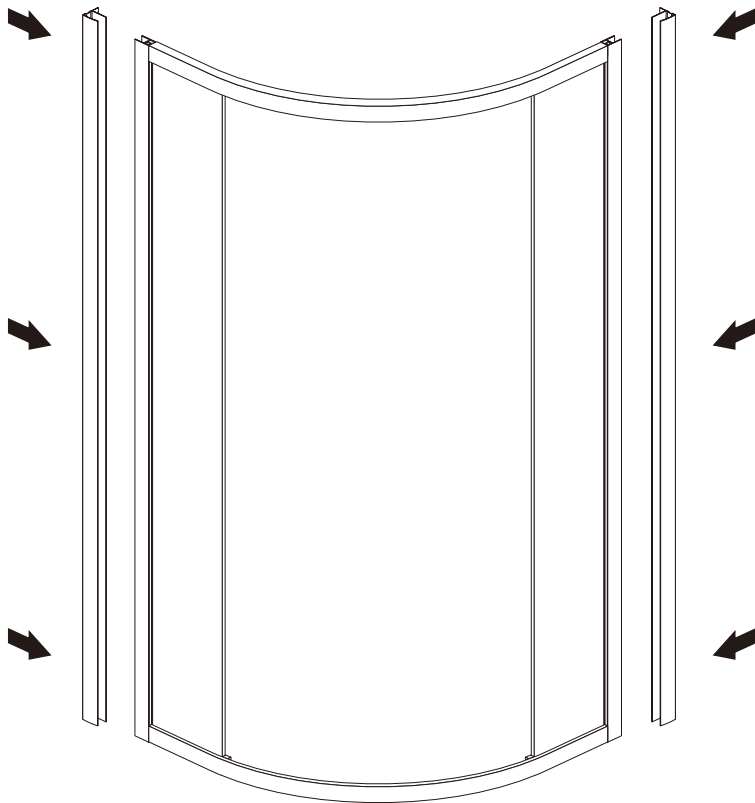

STEP 3

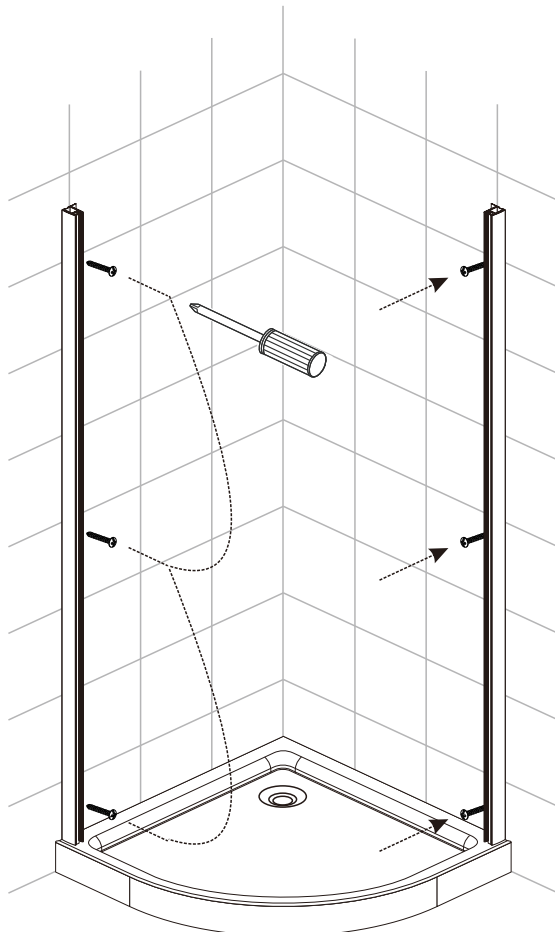
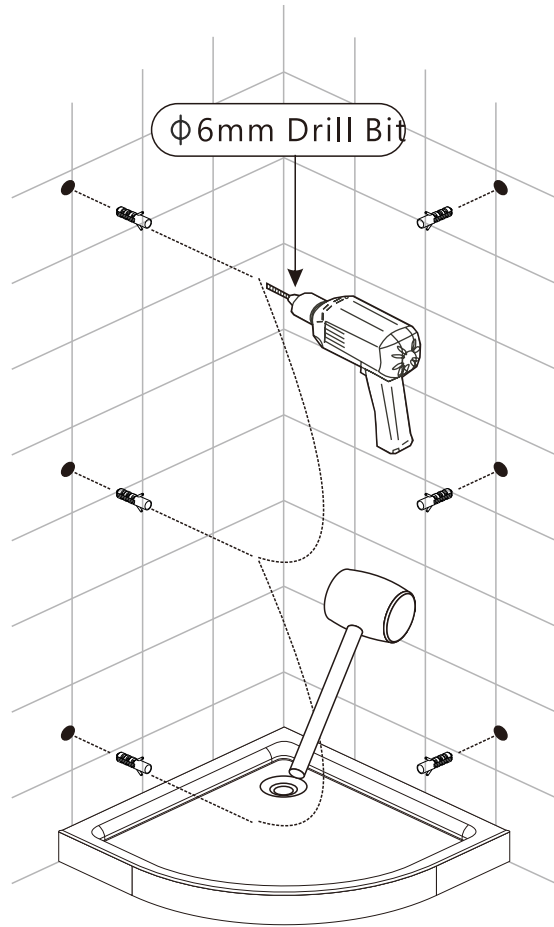

VIEW FROM INSIDE

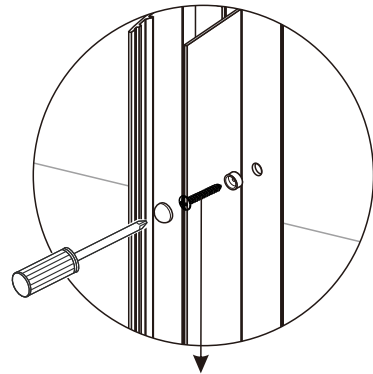

Round Screw
ST4X30

STEP 4

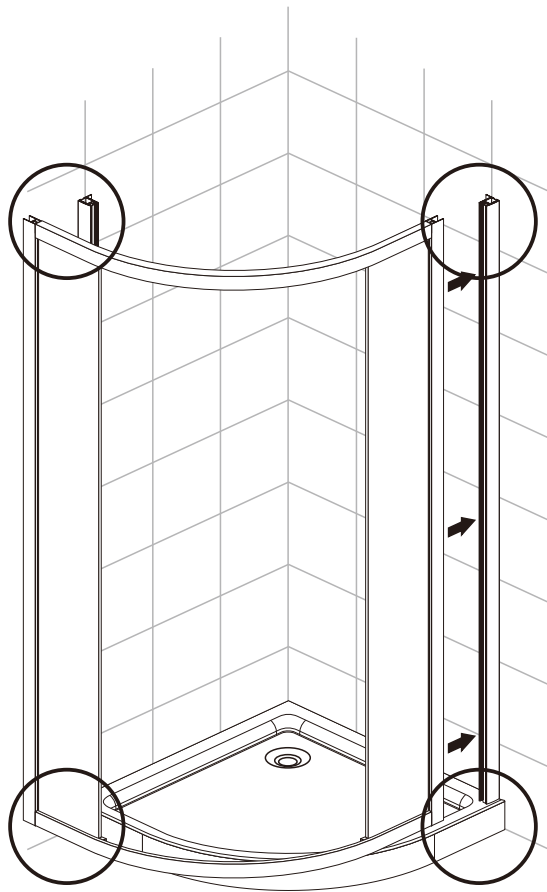

Gently squeeze the frame into both wall profiles

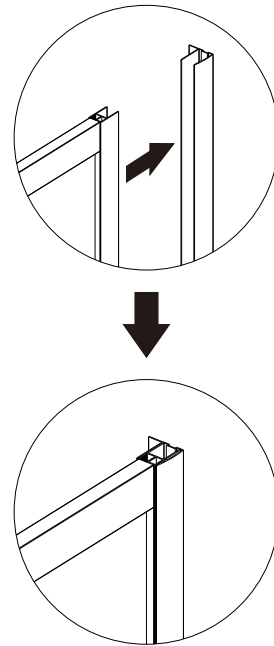

STEP 5

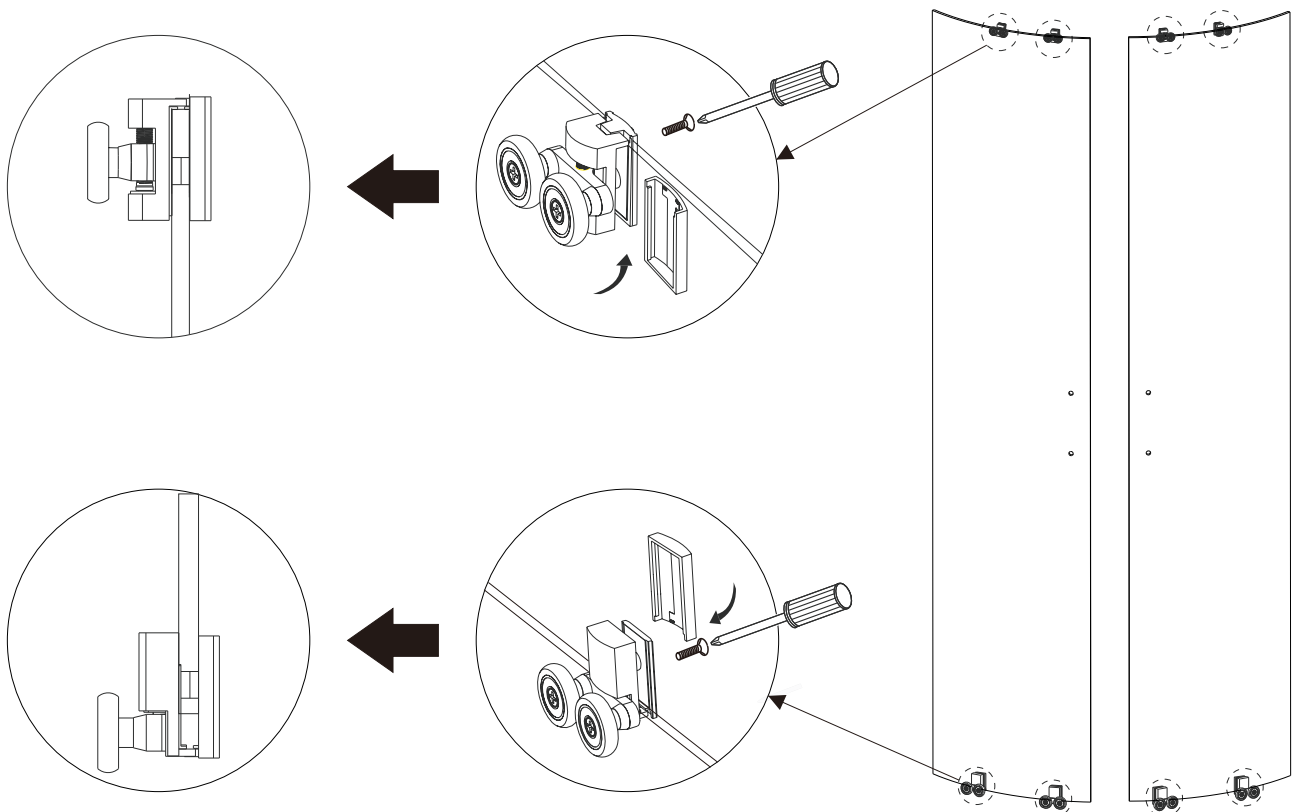

STEP 6

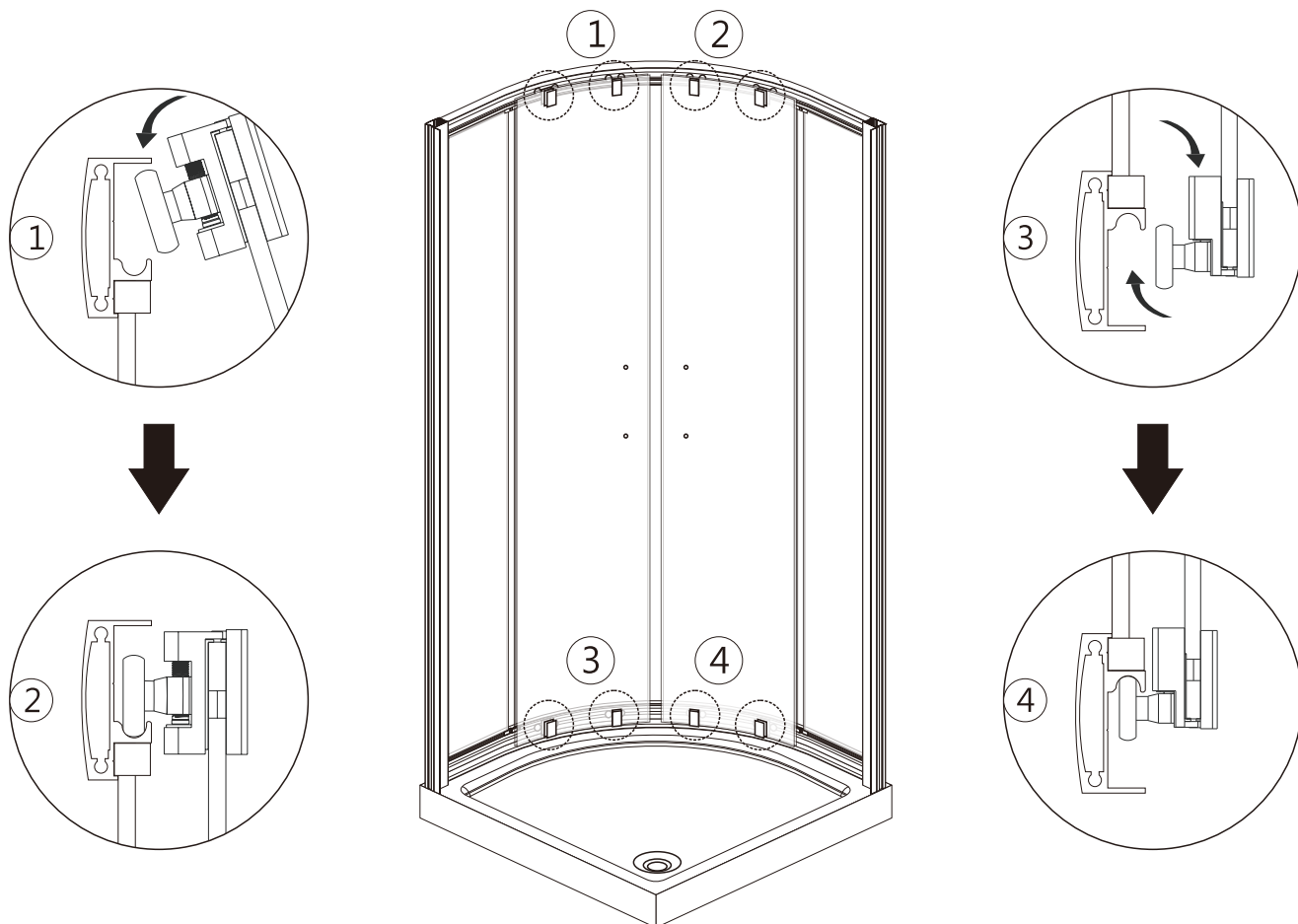

STEP 7

