

Conlift1 LS

Installation and operating instructions



Declaration of conformity

GB: EC declaration of conformity

We, Grundfos, declare under our sole responsibility that the products Conlift1 LS, to which this declaration relates, are in conformity with these Council directives on the approximation of the laws of the EC member states:

- Low Voltage Directive (2006/95/EC).
Standards used: EN 60335-1:2010, EN 60335-2-41:2010 and EN 62233:2008.

This EC declaration of conformity is only valid when published as part of the Grundfos installation and operating instructions (publication number 98491876 0813).

FR: Déclaration de conformité CE

Nous, Grundfos, déclarons sous notre seule responsabilité, que les produits Conlift1 LS, auxquels se réfère cette déclaration, sont conformes aux Directives du Conseil concernant le rapprochement des législations des Etats membres CE relatives aux normes énoncées ci-dessous :

- Directive Basse Tension (2006/95/CE).
Normes utilisées: EN 60335-1:2010, EN 60335-2-41:2010 et EN 62233:2008.

Cette déclaration de conformité CE est uniquement valide lors de sa publication dans la notice d'installation et de fonctionnement Grundfos (numéro de publication 98491876 0813).

NL: EC overeenkomstigheidsverklaring

Wij, Grundfos, verklaren geheel onder eigen verantwoordelijkheid dat de producten Conlift1 LS waarop deze verklaring betrekking heeft, in overeenstemming zijn met de Richtlijnen van de Raad in zake de onderlinge aanpassing van de wetgeving van de EG Lidstaten betreffende:

- Laagspannings Richtlijn (2006/95/EC).
Gebruikte normen: EN 60335-1:2010, EN 60335-2-41:2010 en EN 62233:2008.

Deze EC overeenkomstigheidsverklaring is alleen geldig wanneer deze gepubliceerd is als onderdeel van de Grundfos installatie- en bedieningsinstructies (publicatienummer 98491876 0813).

Bjerringbro, 29th May 2013



Svend Aage Kaae
Technical Director
Grundfos Holding A/S
Poul Due Jensens Vej 7
8850 Bjerringbro, Denmark

Person authorised to compile technical file and empowered to sign the EC declaration of conformity.

Original installation and operating instructions.

CONTENTS

	Page
1. Symbols used in this document	3
2. General description	3
3. Handling	3
4. Applications	4
5. Function	4
6. Operating conditions	4
6.1 Maximum head	4
6.2 Maximum flow rate	4
6.3 Temperatures	4
6.4 Operating mode	4
6.5 Handling of condensates	4
7. Installation	5
7.1 Mechanical installation	5
7.2 Electrical installation	5
8. Startup	6
8.1 Checking the function	6
9. Maintenance and service	6
9.1 Maintenance	6
9.2 Service	6
9.3 Contaminated lifting station or components	6
10. Fault finding	7
11. Accessories	7
12. Technical data	8
13. Marking and approvals	8
13.1 Marking	8
13.2 Approvals	8
14. Disposal	8

1. Symbols used in this document



Warning

If these safety instructions are not observed, it may result in personal injury.



Warning

If these instructions are not observed, it may lead to electric shock with consequent risk of serious personal injury or death.



Caution

If these safety instructions are not observed, it may result in malfunction or damage to the equipment.



Notes or instructions that make the job easier and ensure safe operation.

2. General description

Grundfos Conlift1 LS is a small, compact lifting station with built-in-non-return valve.

3. Handling



Do not drop the Conlift on the floor.



Warning

Prior to installation, read these installation and operating instructions. Installation and operation must comply with local regulations and accepted codes of good practice.



Warning

The use of this product requires experience with and knowledge of the product.

Persons with reduced physical, sensory or mental capabilities must not use this product, unless they are under supervision or have been instructed in the use of the product by a person responsible for their safety.

Children must not use or play with this product.

4. Applications

The Conlift is designed for the pumping of condensate from the following:

- boilers
- air-conditioning systems
- cooling and refrigeration systems
- air dehumidifiers
- evaporators.

The Conlift is suitable for the pumping of condensate which is collected below sewer level or which cannot flow to the sewage system or drain of the building by means of a natural downward slope.



Warning

Condensates from boilers are aggressive as they contain acid.



Warning

Treat (possibly neutralise) condensate from boilers according to local regulations before it is led out into the sewage system.



Warning

The Conlift must not be used for flammable liquids.



Warning

The Conlift must not be installed in potentially explosive environments.

The Conlift can pump condensates not requiring neutralisation, i.e. with pH values of 2.5 or higher. Condensates with pH values up to 2.5 should be neutralised before they leave the Conlift.

Boilers fired with the following fuels normally supply condensate with pH values up to 2.5:

- gas
- liquid gas
- low-sulphur fuel oil according to DIN 51603-1.

Irrespective of the capability of the Conlift, local regulations may require the installation of a neutralisation unit, even for pH values of 2.5 or higher.

5. Function

The condensate runs by natural fall through a hose into the tank. See section 7. *Installation*.

The liquid level in the tank is controlled automatically by a float switch. A micro switch in the float switch will start the pump when the liquid level reaches the start level, and it will stop the pump again when the liquid level has fallen to stop level. The condensate is pumped through the discharge hose to the drain.

The Conlift also has a safety overflow switch with a 1.7-metre electric cable. This overflow switch can be connected to the condensate boiler and set to stop the boiler in case of an alarm.

The Conlift has a thermal switch which stops the motor in case of overload. When the motor has cooled to normal temperature, it will restart automatically.

6. Operating conditions

6.1 Maximum head

5.5 metres.

6.2 Maximum flow rate

600 l/h.

6.3 Temperatures

6.3.1 Ambient temperature

During operation: +5 °C to +35 °C.

6.3.2 Liquid temperature

Average temperature: +50 °C.

6.4 Operating mode

Caution

The Conlift is designed for max. 60 starts per hour.

S3 (intermittent operation): 30 % according to DIN EN 0530 T1. This means that the system is running for 18 seconds and is stopped for 42 seconds.

6.5 Handling of condensates

Condensates from condensate boilers are very aggressive and will attack the material of the building's sewage system.

In order to protect the sewage system, we recommend the use of a neutralisation unit. The neutralisation unit is included in Conlift2 pH+ and is available as an accessory for Conlift1 and Conlift2. See section 11. *Accessories*.

The local discharge regulations regarding condensates from boilers must be met.

7. Installation

Note

The Conlift must be installed according to local regulations.

If not already integrated, a water trap (emission trap) must be fitted in all inlets.

The Conlift is not designed for outdoor use.

7.1 Mechanical installation

See also the quick guide supplied with the Conlift.

When installing the Conlift, observe the following:

- The condensate must run freely into the lifting station.
- The cooling slots in the motor cover must not be covered.
- The lifting station should be easily accessible in order to facilitate maintenance.
- The lifting station must be installed in a well-illuminated and -ventilated room.

7.2 Electrical installation

Carry out the electrical connection according to local regulations.

Check that the supply voltage and frequency correspond to the values stated on the nameplate.

Check that the installation has a 10 A slow-blowing fuse on the mains side and an earth leakage circuit breaker according to IEC 345.

The power supply cable has a Schuko plug or a free cable end. The cable has a length of 2 metres.



Warning

The power supply cable with a free cable end must be connected by an authorised electrician.



Warning

If the power supply cable is damaged, it must be replaced by the manufacturer, the manufacturer's service partner or similarly qualified person.



Warning

Before starting work on or moving the Conlift, make sure that the power supply has been switched off and that it cannot be accidentally switched on.

Warning

As a precaution, the Conlift must be connected to a Schuko socket or socket with earth connection.



We recommend to provide the permanent installation with an earth leakage circuit breaker (ELCB) with a tripping current < 30 mA.

The Conlift must be connected to an external mains switch with a minimum contact gap of 3 mm in all poles.

7.2.1 Cable to condensate source or external alarm

Warning

Before starting work on the Conlift, switch off the power supply and make sure that it cannot be accidentally switched on.

Work on electric systems and components must only be carried out by an authorised electrician.



The Conlift has a safety overflow switch which can be connected to the condensate source or to an external alarm system. The switch is connected to an alarm cable with free cable end.

Alarm systems with a control voltage of 250 VAC, 2.5 A, can be used.

On delivery, the alarm cable is connected to terminals COM1 (brown) and NO4 (blue) of the safety overflow switch. See fig. 1.

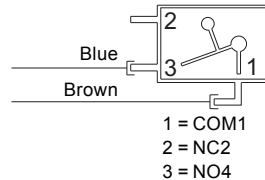

Fig. 1 Wiring diagram

The alarm cable can be connected in two ways, depending on application:

- Shutdown of condensate source
The safety overflow switch can be connected to a Class-II low-voltage circuit.
To enable shutdown of the condensate source, the COM1 and NO4 terminals of the safety overflow switch must be connected in series with the low-voltage thermostat circuit of the condensate source.
- External alarm system
The COM1 and NC2 terminals can be used to close a low-voltage alarm circuit.
To activate an alarm, the COM1 and NC2 terminals of the safety overflow switch must be connected in series with the low-voltage alarm circuit.

TMO5 1152 2211

8. Startup

Note

Start up the Conlift in accordance with local regulations and accepted codes of good practice.

1. Check that all hoses and connections are tight.
2. Connect the power supply.

8.1 Checking the function

Alarm

1. To ensure that the alarm level is reached, squeeze the discharge hose (or close the isolating valve, if fitted), and fill water into the tank. The pump will be started via the float switch.
2. Continue filling water into the tank until the safety overflow switch is activated. If no external alarm is connected to the Conlift, this function can be checked by means of a multimeter.

Note

The safety overflow switch must be activated before the water starts running out of the Conlift.

3. Stop filling water into the tank and stop squeezing the discharge hose. The alarm stops (the switch opens). The pump continues operating. When the stop level is reached, the pump will stop.

After checking the function, push the inlet hose back into the lifting station and let the condensate from the boiler or air-conditioning system run into the tank again.

9. Maintenance and service

Warning



The Conlift must only be serviced by trained service personnel.

Always use original accessories from Grundfos to ensure safe and reliable operation.

Warning



If the power supply cable is damaged, it must be replaced by the manufacturer, the manufacturer's service partner or similarly qualified person.

9.1 Maintenance

The Conlift does not require any special maintenance, but we recommend to check operation and pipe connections at least once a year and to check and clean the collecting tank, if necessary.

9.2 Service

Thanks to the Conlift design, service can easily be performed in case of malfunction or blocked pump.



Warning

The Conlift must only be serviced by trained service personnel.

Warning



Before starting any service work, remove the fuse, pull out the plug, or switch off the power supply. Make sure that the power supply cannot be accidentally switched on.

All rotating parts must have stopped moving.

9.2.1 Conlift

See illustrations on page 9.

Make the following checks and clean the collecting tank, if necessary:

1. Disconnect the power supply.
2. Cut off the flow of condensate from the boiler or other application, or stop the flow of condensate to the Conlift.
3. Make sure that the hoses are not mechanically or chemically damaged.
4. Remove the discharge hose by turning the bayonet coupling, and check the O-ring. The condensate in the hose will not run out due to the non-return valve.
5. If the condensate is running out of the hose, check and clean the non-return valve.
6. Press the side-locking catches and lift off the motor support. Place it in upright position.
7. Remove deposits, dirt, algae and incrustations under running water.

9.3 Contaminated lifting station or components

Caution

If a Conlift has been used for a liquid which is injurious to health or toxic, it will be classified as contaminated.

If Grundfos is requested to service the lifting station, Grundfos must be contacted with details about the pumped liquid, etc. *before* the lifting station is returned for service. Otherwise Grundfos can refuse to accept the lifting station for service.

Incidentally, any application for service, no matter to whom it may be made, must include detailed information about the pumped liquid.

A lifting station returned for service must always be cleaned in the best possible way.

Possible costs of returning the lifting station are to be paid by the customer.

10. Fault finding



Warning

Before starting fault finding, switch off the power supply and make sure that it cannot be accidentally switched on.

Work on electric systems and components must only be carried out by an authorised electrician.

Fault	Cause	Remedy
1. The pump does not run.	a) No power supply.	Connect the power supply.
	b) Fuse is blown.	Replace the fuse (10 A slow-blow fuse).
	c) Power supply cable damaged.	Repair or replace the cable. This must only be carried out by an authorised service workshop or by Grundfos.
	d) Thermal overload switch has tripped: – The motor is not sufficiently cooled. – Deposits in the pump.	Clean the cooling slots in the motor cover. Clean the impeller, pump housing and the entire lifting station.
2. Reduced or no performance.	a) Discharge hose squeezed or broken.	Straighten the discharge hose or replace it. The bending radius of the hose should be at least 60 mm.
	b) The non-return valve does not open.	Remove the discharge connection, and clean the non-return valve.
	c) The motor fan cannot be turned freely.	Clean the pump housing and the impeller.
3. Frequent starts/stops.	a) The non-return valve does not close.	Remove the discharge connection, and clean the non-return valve.
	b) The inlet quantity is too high.	Make sure the inlet quantity is correct.
4. Alarm.	a) The condensate is not pumped out of the tank.	See points 1 and 2.

11. Accessories

The following accessories for the Conlift are available from your local Grundfos supplier.

Accessory/ service part	Description	Product number
pH+ Box	Complete neutralisation unit including fitting accessories, neutralisation granulate and pH indicator.	97936176
Extension hose	6 metres of PVC hose with 10 mm internal diameter including one hose coupling.	97936177
Granulate refill package	Granulate, 4 x 1.4 kg.	97936178
Alarm PCB Conlift	Printed-circuit board (PCB) enabling additional pump start at alarm level or stop of boiler with acoustic alarm.	97936209

12. Technical data

Supply voltage

1 x 230 VAC - 6 %/+ 6 %, 50 Hz, PE.

See nameplate.

Input power

P1 = 70 W.

Input current

I = 0.65 A.

Alarm connection

An external alarm can be connected via the safety overflow switch.

The cable can stand a control voltage of 250 VAC, 2.5 A.

Cable lengths

Alarm and power supply cables: 1.7 metres.

Storage temperature

When stored in dry rooms:

- Empty tank: -10 °C to +50 °C.
- Tank with condensate: above 0 °C (risk of frost not allowed).

Maximum head

5.5 metres.

Maximum flow rate

600 l/h.

pH value of condensate

2.5 or higher.

Density of condensate

Maximum 1000 kg/m³.

Motor protection

- Thermal overload switch: +120 °C.
- Insulation class: F.

Enclosure class

IP20.

Weight

2.0 kg.

Volume

- Tank volume: 2.65 litres.
- Useful volume: 0.9 litre.
- Alarm condition: 2.1 litres.
- Operating condition: 1.7 litres.

Dimensions

See dimensional sketches on page 10.

13. Marking and approvals

13.1 Marking



13.2 Approvals



14. Disposal

This product or parts of it must be disposed of in an environmentally sound way:

1. Use the public or private waste collection service.
2. If this is not possible, contact the nearest Grundfos company or service workshop.

Subject to alterations.

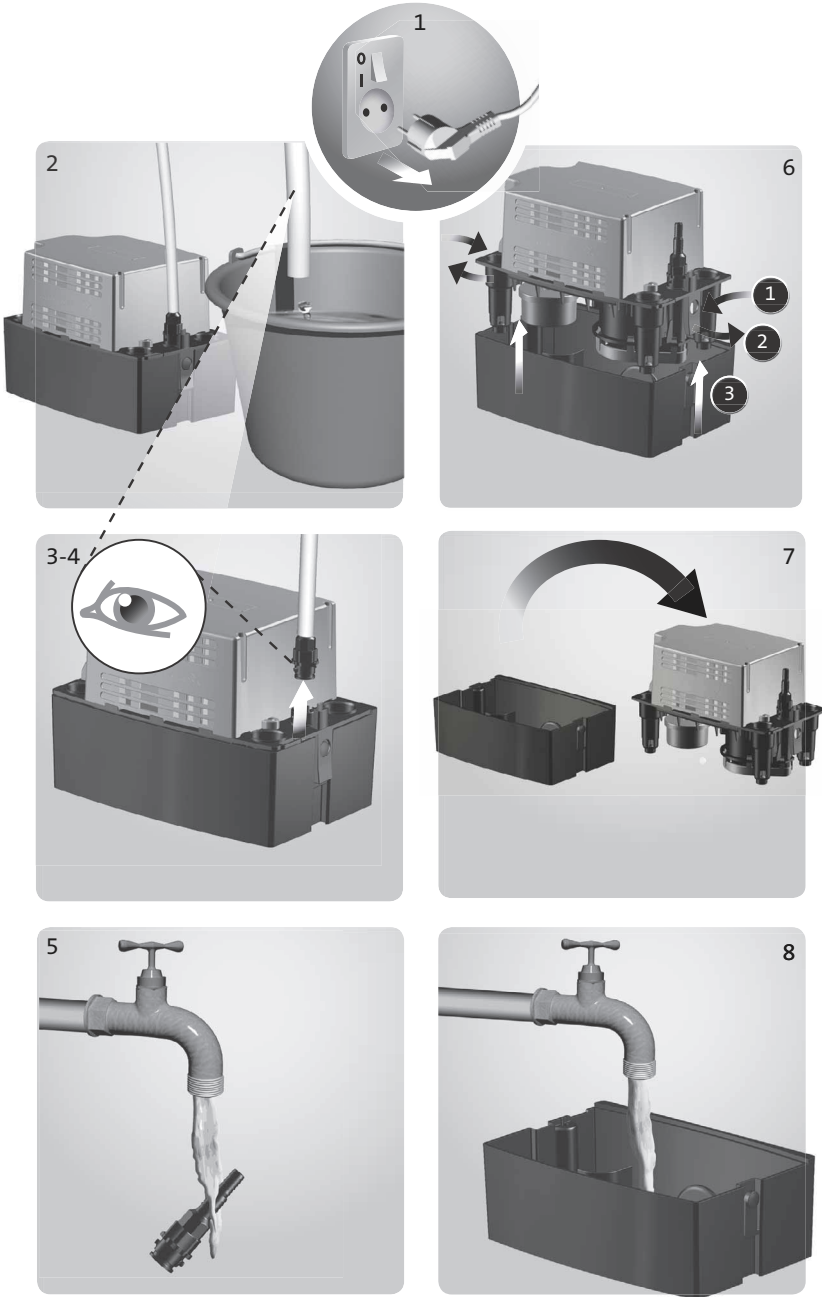

Dimensions, Conlift1 LS

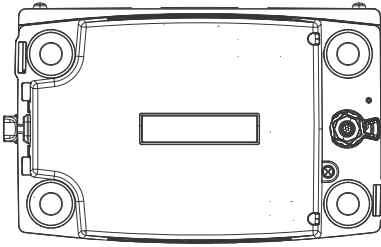
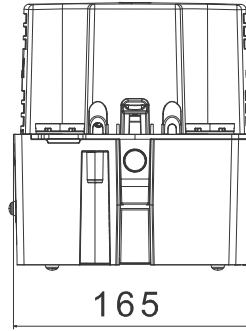
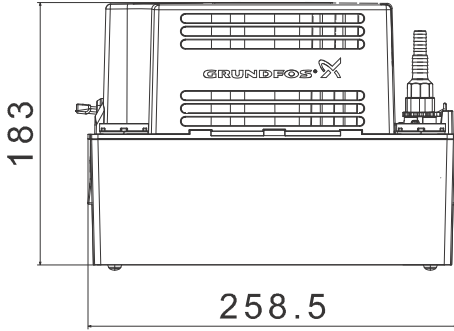

TM05 1227 2411

Argentina

Bombas GRUNDFOS de Argentina S.A.
Ruta Panamericana km. 37.500 Centro
Industrial Garin
1619 Garin Pcia. de B.A.
Phone: +54-3327 414 444
Telefax: +54-3327 45 3190

Australia

GRUNDFOS Pumps Pty. Ltd.
P.O. Box 2040
Regency Park
South Australia 5942
Phone: +61-8-8461-4611
Telefax: +61-8-8340 0155

Austria

GRUNDFOS Pumpen Vertrieb
Ges.m.b.H.
Grundfosstraße 2
A-5082 Grödig/Salzburg
Tel.: +43-6246-883-0
Telefax: +43-6246-883-30

Belgium

N.V. GRUNDFOS Bellux S.A.
Boomsesteenweg 81-83
B-2630 Aartselaar
Tél.: +32-3-870 7300
Télécopie: +32-3-870 7301

Belarus

Представительство ГРУНДФОС в
Минске
220125, Минск
ул. Шафарнянская, 11, оф. 56
Тел.: +7 (375 17) 286 39 72, 286 39 73
Факс: +7 (375 17) 286 39 71
E-mail: minsk@grundfos.com

Bosnia/Herzegovina

GRUNDFOS Sarajevo
Trg Heroja 16,
BiH-71000 Sarajevo
Phone: +387 33 713 290
Telefax: +387 33 659 079
e-mail: grundfos@bih.net.ba

Brazil

BOMBAS GRUNDFOS DO BRASIL
Av. Humberto de Alencar Castelo
Branco, 630
CEP 09850 - 300
São Bernardo do Campo - SP
Phone: +55-11 4393 5533
Telefax: +55-11 4343 5015

Bulgaria

Grundfos Bulgaria EOOD
Slatina District
Iztochna Tangenta street no. 100
BG - 1592 Sofia
Tel. +359 2 49 22 200
Fax. +359 2 49 22 201
email: bulgaria@grundfos.bg

Canada

GRUNDFOS Canada Inc.
2941 Brighton Road
Oakville, Ontario
L6H 6C9
Phone: +1-905 829 9533
Telefax: +1-905 829 9512

China

GRUNDFOS Pumps (Shanghai) Co. Ltd.
50/F Maxdo Center No. 8 XingYi Rd.
Hongqiao development Zone
Shanghai 200336
PRC
Phone: +86 21 612 252 22
Telefax: +86 21 612 253 33

Croatia

GRUNDFOS CROATIA d.o.o.
Cebini 37, Buzin
HR-10010 Zagreb
Phone: +385 1 6595 400
Telefax: +385 1 6595 499
www.grundfos.hr

Czech Republic

GRUNDFOS s.r.o.
Čajkovského 21
779 00 Olomouc
Phone: +420-585-716 111
Telefax: +420-585-716 299

Denmark

GRUNDFOS DK A/S
Martin Bachs Vej 3
DK-8850 Bjerringbro
Tlf.: +45-87 50 50 50
Telefax: +45-87 50 51 51
E-mail: info_GDK@grundfos.com
www.grundfos.com/DK

Estonia

GRUNDFOS Pumps Eesti OÜ
Peterburi tee 92G
11415 Tallinn
Tel: + 372 606 1690
Fax: + 372 606 1691

Finland

OY GRUNDFOS Pumput AB
Mestarintie 11
FIN-01730 Vantaa
Phone: +358-(0)207 889 900
Telefax: +358-(0)207 889 550

France

Pompes GRUNDFOS Distribution S.A.
Parc d'Activités de Chesnes
57, rue de Malacombe
F-38290 St. Quentin Fallavier (Lyon)
Tél.: +33-4 74 82 15 15
Télécopie: +33-4 74 94 10 51

Germany

GRUNDFOS GMBH
Schlüterstr. 33
40699 Erkrath
Tel.: +49-(0) 211 929 69-0
Telefax: +49-(0) 211 929 69-3799
e-mail: infoservice@grundfos.de
Service in Deutschland:
e-mail: kundendienst@grundfos.de

HILGE GmbH & Co. KG
Hilgestrasse 37-47
55292 Bodenheim/Rhein
Germany
Tel.: +49 6135 75-0
Telefax: +49 6135 1737
e-mail: hilge@hilge.de

Greece

GRUNDFOS Hellas A.E.B.E.
20th km. Athinon-Markopoulou Av.
P.O. Box 71
GR-19002 Peania
Phone: +0030-210-66 83 400
Telefax: +0030-210-66 46 273

Hong Kong

GRUNDFOS Pumps (Hong Kong) Ltd.
Unit 1, Ground floor
Siu Wai Industrial Centre
29-33 Wing Hong Street &
68 King Lam Street, Cheung Sha Wan
Kowloon
Phone: +852-27861706 / 27861741
Telefax: +852-27858664

Hungary

GRUNDFOS Hungária Kft.
Park u. 8
H-2045 Törökbálint,
Phone: +36-23 511 110
Telefax: +36-23 511 111

India

GRUNDFOS Pumps India Private
Limited
118 Old Mahabalipuram Road
Thoraipakkam
Chennai 600 096
Phone: +91-44 2496 6800

Indonesia

PT GRUNDFOS Pompa
Jl. Rawa Sumur III, Blok III / CC-1
Kawasan Industri, Pulogadung
Jakarta 13930
Phone: +62-21-460 6909
Telefax: +62-21-460 6910 / 460 6901

Ireland

GRUNDFOS (Ireland) Ltd.
Unit A, Merrywell Business Park
Ballymount Road Lower
Dublin 12
Phone: +353-1-4089 800
Telefax: +353-1-4089 830

Italy

GRUNDFOS Pompe Italia S.r.l.
Via Gran Sasso 4
I-20060 Truccazzano (Milano)
Tel.: +39-02-95838112
Telefax: +39-02-95309290 / 95838461

Japan

GRUNDFOS Pumps K.K.
Gotanda Metalon Bldg., 5F,
5-21-15, Higashi-gotanda
Shiagawa-ku, Tokyo
141-0022 Japan
Phone: +81 35 448 1391
Telefax: +81 35 448 9619

Korea

GRUNDFOS Pumps Korea Ltd.
6th Floor, Aju Building 679-5
Yeoksam-dong, Kangnam-ku, 135-916
Seoul, Korea
Phone: +82-2-5317 600
Telefax: +82-2-5633 725

Latvia

SIA GRUNDFOS Pumps Latvia
Deglava biznesa centrs
Augusta Deglava iela 60, LV-1035, Rīga,
Tālr.: + 371 714 9640, 7 149 641
Fakss: + 371 914 9646

Lithuania

GRUNDFOS Pumps UAB
Smolensko g. 6
LT-03201 Vilnius
Tel: + 370 52 395 430
Fax: + 370 52 395 431

Malaysia

GRUNDFOS Pumps Sdn. Bhd.
7 Jalan Peguam U1/25
Glenmarie Industrial Park
40150 Shah Alam
Selangor
Phone: +60-3-5569 2922
Telefax: +60-3-5569 2866

Mexico

Bombas GRUNDFOS de México S.A. de C.V.
Boulevard TLC No. 15
Parque Industrial Stiva Aeropuerto
Apodaca, N.L. 66600
Phone: +52-81-8144 4000
Telefax: +52-81-8144 4010

Netherlands

GRUNDFOS Netherlands
Veluwezoom 35
1326 AE Almere
Postbus 22015
1302 CA ALMERE
Tel.: +31-88-478 6336
Telefax: +31-88-478 6332
E-mail: info_gnl@grundfos.com

New Zealand

GRUNDFOS Pumps NZ Ltd.
17 Beatrice Tinsley Crescent
North Harbour Industrial Estate
Albany, Auckland
Phone: +64-9-415 3240
Telefax: +64-9-415 3250

Norway

GRUNDFOS Pumper A/S
Strømsveien 344
Postboks 235, Leirdal
N-1011 Oslo
Tlf.: +47-22 90 47 00
Telefax: +47-22 32 21 50

Poland

GRUNDFOS Pompy Sp. z o.o.
ul. Klonowa 23
Baranowo k. Poznania
PL-62-081 Przeźmierowo
Tel: (+48-61) 650 13 00
Fax: (+48-61) 650 13 50

Portugal

Bombas GRUNDFOS Portugal, S.A.
Rua Calvet de Magalhães, 241
Apartado 1079
P-2770-153 Paço de Arcos
Tel.: +351-21-440 76 00
Telefax: +351-21-440 76 90

Romania

GRUNDFOS Pompe România SRL
Bd. Biruintei, nr 103
Pantelimon county Ilfov
Phone: +40 21 200 4100
Telefax: +40 21 200 4101
E-mail: romania@grundfos.ro

Russia

ООО Грундфос
Россия, 109544 Москва, ул. Школьная
39
Тел. (+7) 495 737 30 00, 564 88 00
Факс (+7) 495 737 75 36, 564 88 11
E-mail grundfos.moscow@grundfos.com

Serbia

GRUNDFOS Predstavništvo Beograd
Dr. Milutina Ivkovića 2a/29
YU-11000 Beograd
Phone: +381 11 26 47 877 / 11 26 47 496
Telefax: +381 11 26 48 340

Singapore

GRUNDFOS (Singapore) Pte. Ltd.
25 Jalan Tukang
Singapore 619264
Phone: +65-6681 9688
Telefax: +65-6681 9689

Slovenia

GRUNDFOS d.o.o.
Šlandrova 8b, SI-1231 Ljubljana-Črnuče
Phone: +386 1 568 0610
Telefax: +386 1 568 0619
E-mail: slovenia@grundfos.si

South Africa

GRUNDFOS (PTY) LTD
Corner Mountjoy and George Allen
Roads
Wilbart Ext. 2
Bedfordview 2008
Phone: (+27) 11 579 4800
Fax: (+27) 11 455 6066
E-mail: lsmart@grundfos.com

Spain

Bombas GRUNDFOS España S.A.
Camino de la Fuentecilla, s/n
E-28110 Algete (Madrid)
Tel.: +34-91-848 8800
Telefax: +34-91-628 0465

Sweden

GRUNDFOS AB
Box 333 (Lunnagårdsgatan 6)
431 24 Mölndal
Tel.: +46 31 332 23 000
Telefax: +46 31 331 94 60

Switzerland

GRUNDFOS Pumpen AG
Bruggacherstrasse 10
CH-8117 Fällanden/ZH
Tel.: +41-1-806 8111
Telefax: +41-1-806 8115

Taiwan

GRUNDFOS Pumps (Taiwan) Ltd.
7 Floor, 219 Min-Chuan Road
Taichung, Taiwan, R.O.C.
Phone: +886-4-2305 0868
Telefax: +886-4-2305 0878

Thailand

GRUNDFOS (Thailand) Ltd.
92 Chaloeam Phrakiat Rama 9 Road,
Dokmai, Pravej, Bangkok 10250
Phone: +66-2-725 8999
Telefax: +66-2-725 8998

Turkey

GRUNDFOS POMPA San. ve Tic. Ltd.
Sti.
Gebze Organize Sanayi Bölgesi
Ihsan dede Caddesi,
2. yol 200. Sokak No. 204
41490 Gebze/ Kocaeli
Phone: +90 - 262-679 7979
Telefax: +90 - 262-679 7905
E-mail: satis@grundfos.com

Ukraine

ТОВ ГРУНДФОС УКРАЇНА
01010 Київ, Вул. Московська 86,
Тел.: (+38 044) 390 40 50
Факс: (+38 044) 390 40 59
E-mail: ukraine@grundfos.com

United Arab Emirates

GRUNDFOS Gulf Distribution
P.O. Box 16768
Jebel Ali Free Zone
Dubai
Phone: +971 4 8815 166
Telefax: +971 4 8815 136

United Kingdom

GRUNDFOS Pumps Ltd.
Grovebury Road
Leighton Buzzard/Beds. LU7 4TL
Phone: +44-1525-850000
Telefax: +44-1525-850011

U.S.A.

GRUNDFOS Pumps Corporation
17100 West 118th Terrace
Olathe, Kansas 66061
Phone: +1-913-227-3400
Telefax: +1-913-227-3500

Uzbekistan

Grundfos Tashkent, Uzbekistan The Rep-
resentative Office of Grundfos Kazakhstan
in Uzbekistan
38a, Oybek street, Tashkent
Телефон: (+998) 71 150 3290 / 71 150 3291
Факс: (+998) 71 150 3292

Addresses Revised 06.05.2013

DWT:60161340

98491876 0813

ECM: 1116516

The name Grundfos, the Grundfos logo, and be think innovate are registered trademarks owned by Grundfos Holding A/S or Grundfos A/S, Denmark. All rights reserved worldwide.
© Copyright Grundfos Holding A/S