

INSTALLATION, OPERATION AND MAINTENANCE INSTRUCTIONS FOR Warm Air Curtain Heaters

Catalogue Number: HE7402RF 3kW & HE7420RF 4.5kW- 230/240V

PLEASE RETAIN THIS LEAFLET FOR FUTURE MAINTENANCE

MODELS

These units are 622mm wide 3kW & 4.5kW modular heaters designed for mounting above doorways and similar entrances, and may be used as space heaters. 1040mm 4.5kW and 6kW modules are also available.

MOUNTING

When mounted over a standard shop doorway the unit should be fitted as low as possible and not more than 2.3 meters from ground level. A single unit will provide reasonable coverage for a one metre doorway, and for wider doorways units can be mounted end to end.

The unit should be positioned so that the airflow is not obstructed by any part of the doorframe.

INSTALLATION

Carefully unpack the unit and remove the top cover fixing screws. The heater may be mounted using the mounting bracket provided.

Loosen mounting screws, allowing the mounting bracket to be removed from the unit. Making sure that the mounting bracket is horizontal, fix the bracket to the wall using 4 x No 8 wood screws.

Place the unit on the mounting bracket ensuring the washers are spaced as shown on diagram 2 (a plain washer either side of the mounting bracket).

Tighten screws to hold the unit at the required angle.

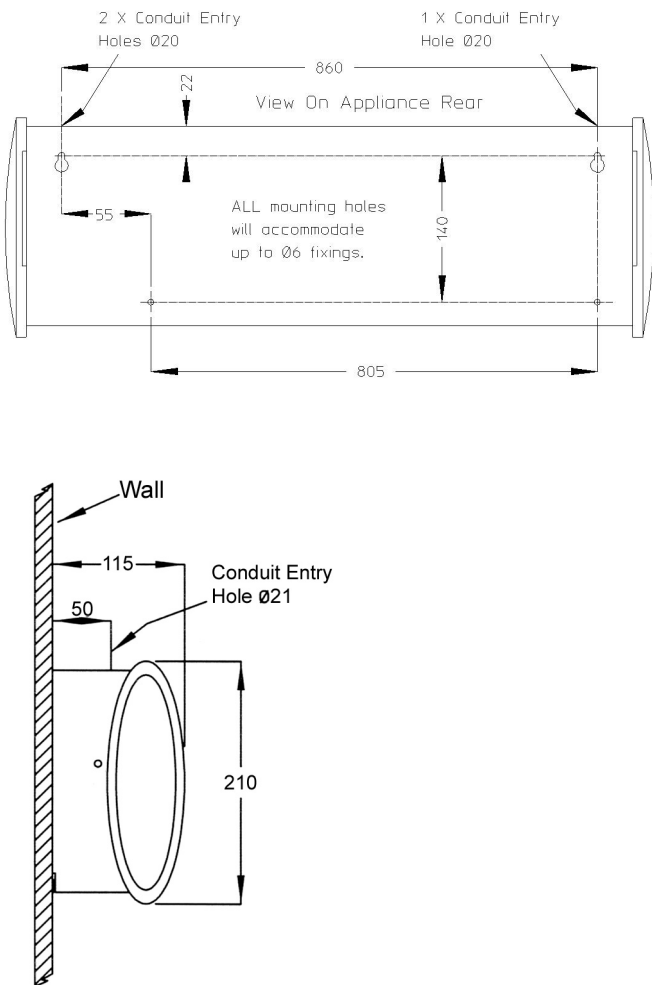

Fig 1 OUTLINE DRAWING

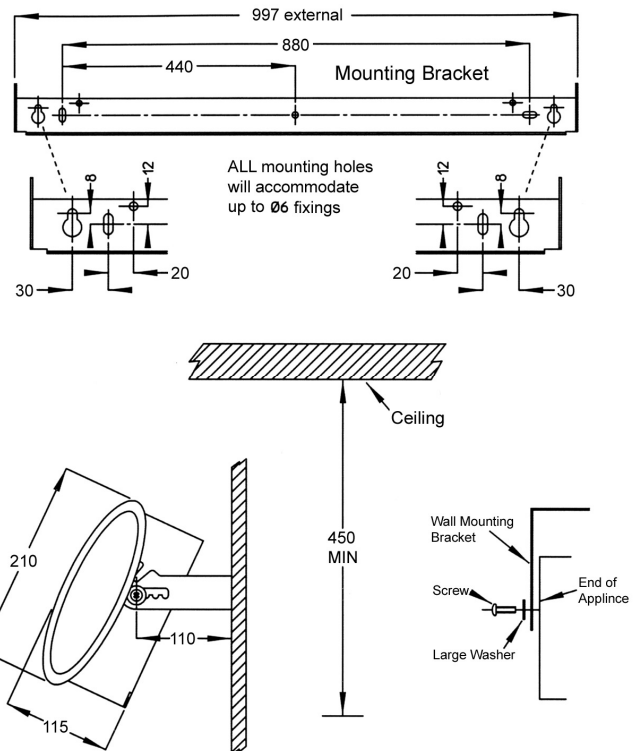

Fig 2 WALL BRACKET ASSEMBLY

The heater may also be mounted directly onto a suitable wall or bearer by four No. 8 wood screws through the holes provided in the back of the unit casing. Keyhole slots are provided for the top two fixings (fig 1).

ELECTRICAL CONNECTIONS

These units are suitable for connection to a 230/240 volt 50 Hz single phase ac supply. The heaters consume 4.5kW & 6kW respectively at 240 volts when switched to the full heat position.

Model HE7402RF - 3kW

Model HE7420RF - 4.5kW

The appliance should be connected to the supply via a circuit in which there is an all-pole switch. Test for correct operation and refit the cover.

Fig 3 WIRING DIAGRAM

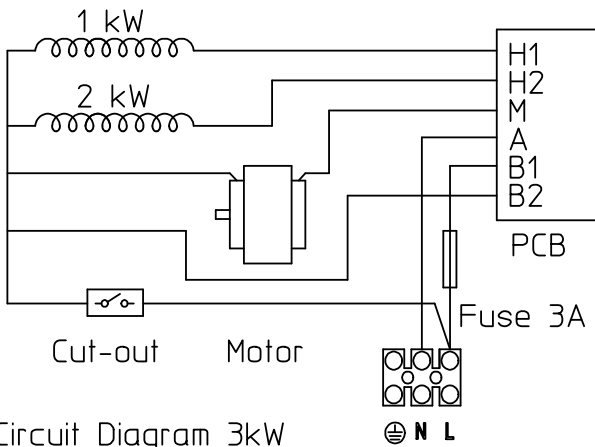

Circuit Diagram 3kW
Heaters for Wireless Controls

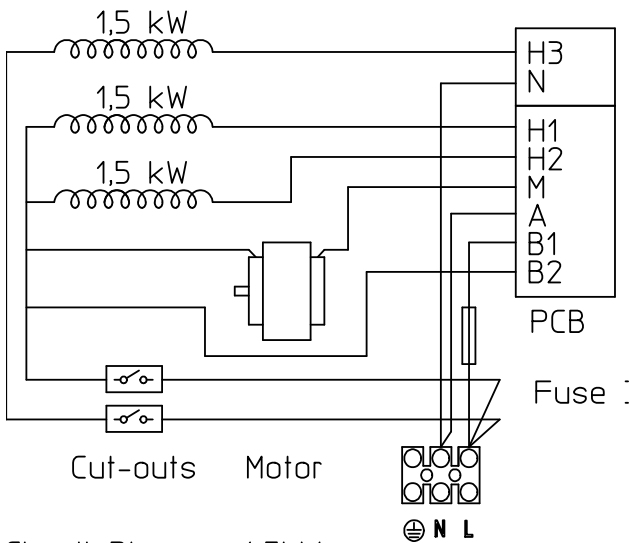

Circuit Diagram 4,5kW
Heaters for Wireless Controls

NOTE: The unit MUST be reliably earthed.

OPERATION

This heater is controlled by a Celsia Zone Controller CZC1 and can only be used when connected. Each CZC1 can control any number of heaters. The heater has an indicator light positioned on the fascia panel on the top left side. The light may be:

- Green** - when no heat is needed
- Yellow** - when some heat is needed to maintain the room temperature
- Red** - when the heater is on full power
- Fast Flashing Red** - when the heater has overheated and an Electronic Safety Control has switched the heater off.

Please refer to the user and operating instructions for the CZC1 for detailed instructions.

ELECTRONIC SAFETY CONTROL

The appliance is fitted with an Electronic Safety Control (ES). This is a safety device which switches the heater off if, for any reason, the appliance overheats. The overheating is indicated by fast flashing red light. The ES control can only be re-set after the appliance has cooled down. In order to re-set the ES control, proceed as follows:

- Switch the appliance off at the mains by using the isolator switch and leave to cool down for approximately 5 minutes.
 - Switch appliance back on and the ES control will re-set.
- Ensure that the appliance is functioning correctly. If the ES control operates again, the appliance should be checked by a competent electrician.

MAINTENANCE

Always ensure that the main external electricity supply is switched off before attending to the servicing of your Claudgen Screen-Zone heater.

To obtain best results from your heater it is necessary to avoid the build up of dust and dirt within the unit and on the air inlet and discharge grills. For this reason regular cleaning is necessary, paying particular attention to the removal of dirt build up on the rotor blades. A single drop of light oil should be applied to the motor bearing from time to time.

TO REPLACE THE FAN HEATER ASSEMBLY

- a) Remove the top cover.
- b) Disconnect the internal wiring from the main terminal block and earth stud.
- c) Release the three fixings which secure the switch bracket to the right hand of the main case.
- d) Remove the four nuts and washers fixing the fan heater assembly to the back of the case.
- e) The fan heater assembly can now be eased forward and removed from the heater case.
- f) Fit replacement fan heater and reassemble in reverse order.

SPARES

It is essential when ordering spares or replacement parts to state the model number and the serial number on the rating plate fixed to the top of the unit.

In the interest of progress the Company reserve the right to vary specifications from time to time without notice. The material listed is offered subject to the Company's General Conditions of Sale, a copy of which can be obtained on request.

NOTE: DO NOT COVER any of the air inlet or outlet grills, at any time.