



INSTALLATION, OPERATION AND MAINTENANCE
INSTRUCTIONS FOR

Claudgen Screen-Zone 9kW & 12kW Warm Air Curtain Heaters

Catalogue Numbers: CA1309S, CA1312S



These units are 1305 mm 9 or 12 kW air curtain heaters designed for mounting above entrances. The discharge width of the air curtain is one metre. It is supplied complete with a remote mounting control box. The appliance may be supported/mounted in a variety of ways.

PLEASE RETAIN THIS LEAFLET FOR FUTURE MAINTENANCE

CONSORT EQUIPMENT PRODUCTS LTD

REGISTERED OFFICE: THORNTON INDUSTRIAL ESTATE

MILFORD HAVEN, PEMBROKESHIRE, SA73 2RT

TEL: 01646 692172 FAX: 01646 695195

WEB: www.consortepl.com EMAIL: enquiries@consortep.com

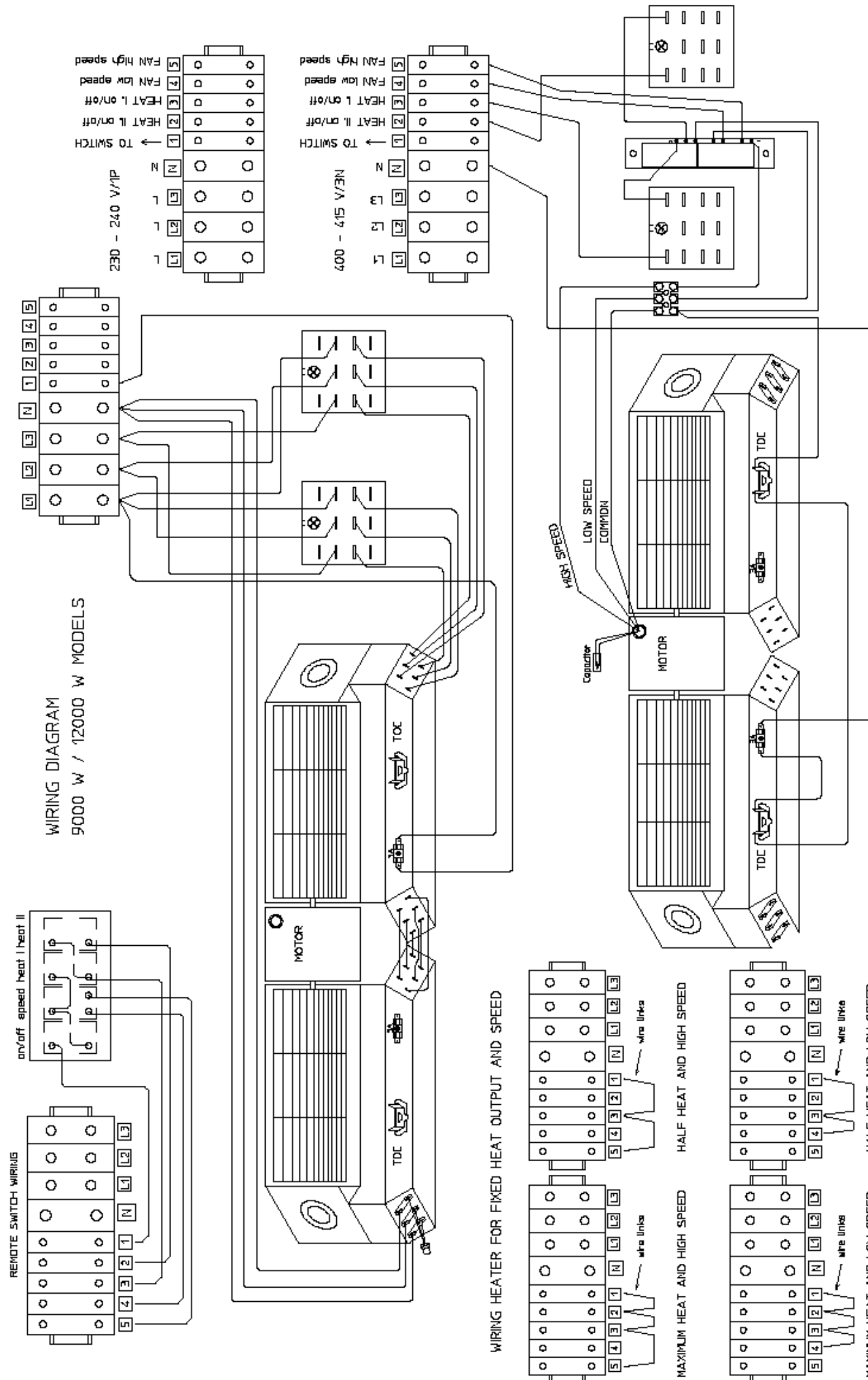

ELECTRICAL CONNECTIONS

The heater is suitable for connection to a 415 volt 3 phase 50Hz supply. With modification the unit can also be on a 240 volt 50Hz supply by linking terminals L1, L2 and L3 on the main input terminal block and connecting to the supply LIVE. On full heat setting the load is 9 kW (CA1309S) & 12kW(CA1312S). The connections between the unit and remote switch box are shown on the rear of this instruction sheet, Fig 8.

For safety reasons a good earth connection must ALWAYS be made to the unit and the control box. On the heater the earth terminal is adjacent to the terminal block and is clearly marked with the symbol . The unit should be wired in accordance with BS7671 latest edition requirements for electrical installations. The installer should ensure that a suitable fused isolating switch is connected in the mains supply.

Electrical Data		CA1309	CA1312	CA1309	CA1312
Supply voltage		230V single phase 50Hz		415V three phase 50Hz	
Total load	kW	9	12	9	12
	A/pha	37.5	50.1	12.5	16.7
Motor power	W	184			
Max Running current	Amps	0.8			
Internal fuse size amps	Amps	2			
External fuse size amps	A/pha	40	63	16	20
Cable terminal size		10mm ² Max			
Mains terminal block position		Bottom of base unit Terminals L1; N & E		Bottom of base unit. Terminals N; L1; L2 & L3	
Control terminal block cable size		4mm ² Max			
Control terminal block position		Bottom of base unit Terminals 1-5		Bottom of base unit. Terminals 1-5	
Control terminal block current	Amps	0.8			

FUSES

The motor and switch circuits are protected by two fuses which have a 3 amp rating. Ensure that any replacement is of the correct size and rating.

MAINTENANCE

ALWAYS ENSURE THAT THE MAIN EXTERNAL ELECTRICITY SUPPLY IS SWITCHED OFF BEFORE SERVICING OF THIS SCREEN-ZONE HEATER.

To obtain the best results from the heater it is essential to avoid the accumulation of dust and dirt within the unit and on the inlet and discharge grilles. Regular cleaning is necessary with particular attention to the fronts and backs of the fan motor blades. Cleaning of the fan is best carried out with a soft brush.

CONTROLS

The units are designed to provide 2 levels of heat ie half heat and full heat, together with 2 fan speeds, normal and boost. The remote control box houses 4 switches. The switch plate is marked as shown below. The functions of the switches are as follows:-

SWITCH 1 (left-hand)	ON/OFF
SWITCH 2	FAN SPEED CONTROL
SWITCH 3	½ HEAT ON/OFF
SWITCH 4	½ HEAT ON/OFF



TO REPLACE A SWITCH IN THE CONTROL BOX

- Switch off the mains supply
- Remove the switch box cover.
- Disconnect the wiring to the switch.
- Release the spring clips and push out the switch.
- Fit the replacement switch, reconnect the wiring and replace the cover.

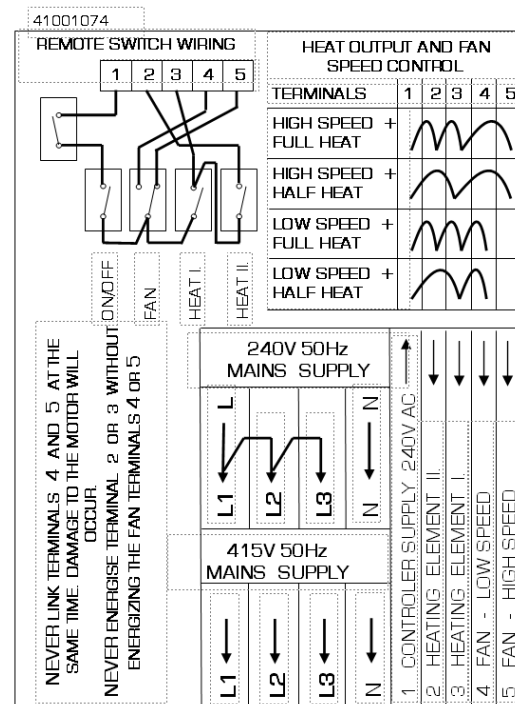
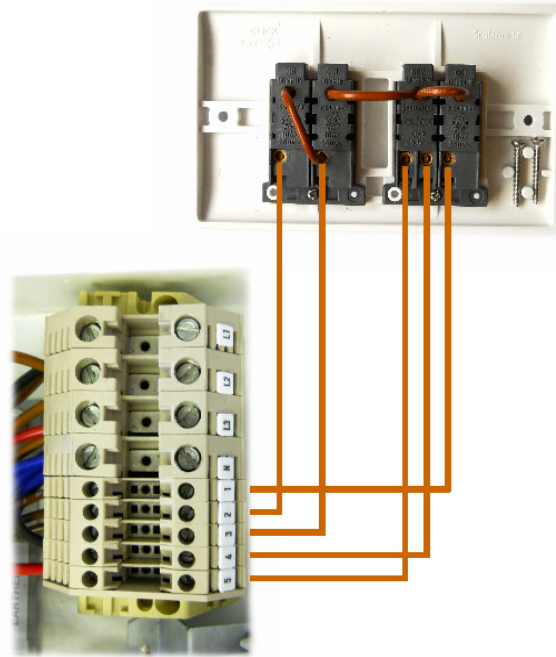

THERMAL CUT-OUTS

There are 2 thermal cut-outs protecting the heater, positioned along the heater box. These cut-outs are connected in series and each or both may operate in the event of fan failure or restriction to the free flow of air through the unit. The unit is protected by manual type cut-outs which may only be reset by hand when the heater is switched OFF and has cooled down. If the cut-outs trip, check the inlet and outlet grilles for airflow restrictions.

TO RESET THE CUT-OUTS

- The cut-outs are reset by switching OFF mains power to the appliance and allowing the appliance to cool for 20 minutes.
- Remove the appliance lid and locate the 2 cut-outs. Ensure mains power is OFF. Reset each cut-out by pressing the white 5 mm square reset button located on each cut-out.
- Replace appliance lid. Switch ON the appliance. The cut-outs will be reset. If the cut-outs trip again a qualified electrician should be consulted.

SPARES

It is essential when ordering spares or replacement parts to state the model number CA1309S or CA1312S and the serial number on the rating plate fixed to the top of the unit.

In the interest of progress the Company reserves the right to vary specifications from time to time without notice. The material listed is offered subject to the Company's General Conditions of Sale, a copy of which can be obtained on request.

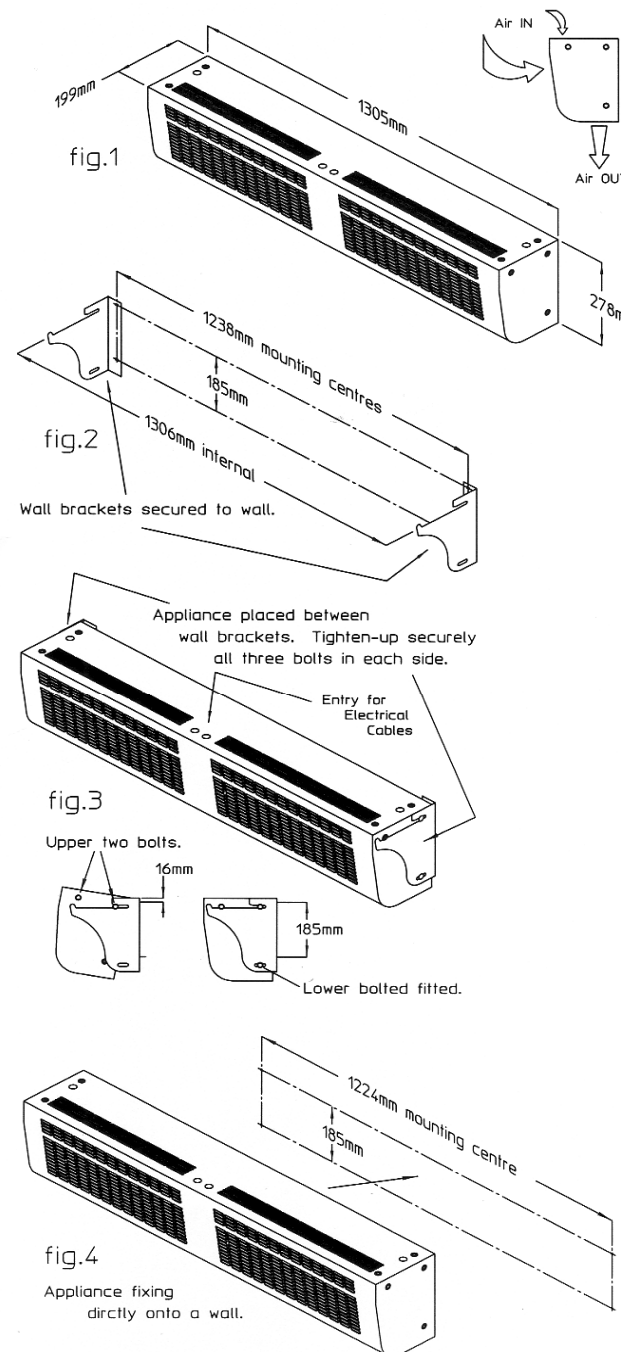

MOUNTING

When mounted over a doorway, the unit should be mounted as low as possible and not more than 3.4 metres above the floor. A single unit will give adequate coverage for a 1.2 metre doorway. For wider doorways, units may be mounted end to end. The heater should be mounted so that the inlet or outlet air flow are not obstructed in any way. A clearance of at least 300 mm should be maintained around the inlet and outlet grilles.

INSTALLATION

Having removed the appliance lid, to acquire these Instructions, also ensure that the Remote Control Switch Box, which is packed inside the appliance with these Instructions, is removed and retained.

The appliance 'air flow' and 'external dimensions' are shown in Fig 1.

The heater may be mounted in one of several ways ie:-

1. Wall Mounting

a. Using WALL BRACKETS supplied. Onto a suitable vertical wall or bearers, the 2 wall brackets are secured at the centres shown in Fig 2. The appliance, with 2 upper bolts threaded securely into each face, is then fitted onto/between the wall brackets as shown in Fig 3. The lower fixing bolts are then fitted through each wall bracket into each side of the appliance.

The upper 2 bolts allow the appliance to be slipped onto, and held by, the wall brackets. The fitting of the lower bolts in each side locks the appliance to the brackets.

Tighten-up securely all 3 bolts in each side.

b. DIRECTLY to a suitable vertical wall or bearers.

Using 4 x No.12 wood screws. Screw through the holes in the appliance case rear, at the centres shown in Fig 4. Keyhole slots are provided for the upper 2 fixing screws, allowing the appliance to be initially located. The lower 2 fixing screws pass through the appliance rear, supporting the appliance and preventing any movement up off the upper 2 screws.

The wall surface to which the appliance is to be mounted must be flat to avoid any distortion of the appliance casing.

2. Suspended/Hanging

a. Using Ø20mm CONDUIT.

The appliance may be suspended by Ø20mm conduit via two suitable holes provided in the top of the appliance, see Fig 5.

b. Studding.

The heater offers four M8 threaded holes as shown in Fig 6. from which the appliance may be suspended.