

INSTALLATION, OPERATION AND MAINTENANCE INSTRUCTIONS FOR Warm Air Curtain Heaters

Catalogue Number: HE8320 4.5kW & HE7426 6kW- 230/240V

PLEASE RETAIN THIS LEAFLET FOR FUTURE MAINTENANCE

MODELS

These units are 1035mm wide 4.5kW & 6kW modular heaters designed for mounting above doorways and similar entrances, and may be used as space heaters. 622mm 3kW and 4.5kW modules are also available.

MOUNTING

When mounted over a standard shop doorway the unit should be fitted as low as possible and not more than 2.3 meters from ground level. A single unit will provide reasonable coverage for a one metre doorway, and for wider doorways units can be mounted end to end.

The unit should be positioned so that the airflow is not obstructed by any part of the doorframe.

INSTALLATION

Carefully unpack the unit and remove the top cover fixing screws. The heater may be mounted using the mounting bracket provided.

Loosen mounting screws, allowing the mounting bracket to be removed from the unit. Making sure that the mounting bracket is horizontal, fix the bracket to the wall using 4 x No 8 wood screws.

Place the unit on the mounting bracket ensuring the washers are spaced as shown on diagram 2 (a plain washer either side of the mounting bracket).

Tighten screws to hold the unit at the required angle.

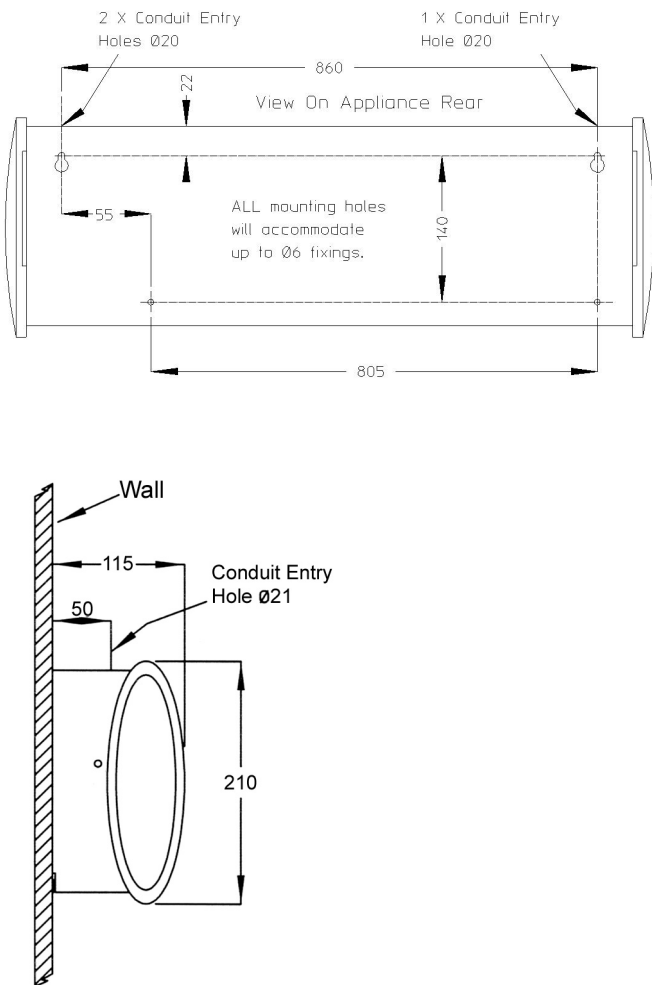

Fig 1 OUTLINE DRAWING

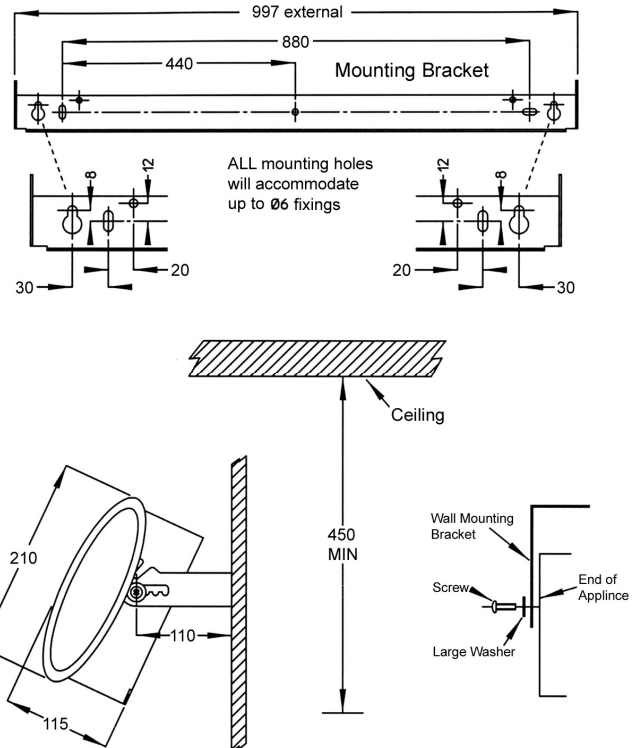

Fig 2 WALL BRACKET ASSEMBLY

The heater may also be mounted directly onto a suitable wall or bearer by four No. 8 wood screws through the holes provided in the back of the unit casing. Keyhole slots are provided for the top two fixings (fig 1).

ELECTRICAL CONNECTIONS

These units are suitable for connection to a 230/240 volt 50 Hz single phase ac supply. The heaters consume 4.5kW & 6kW respectively at 240 volts when switched to the full heat position.

Model HE8320 - 4.5kW

Model HE7426 - 6kW

The appliance should be connected to the supply via a circuit in which there is an all-pole switch. Test for correct operation and refit the cover.

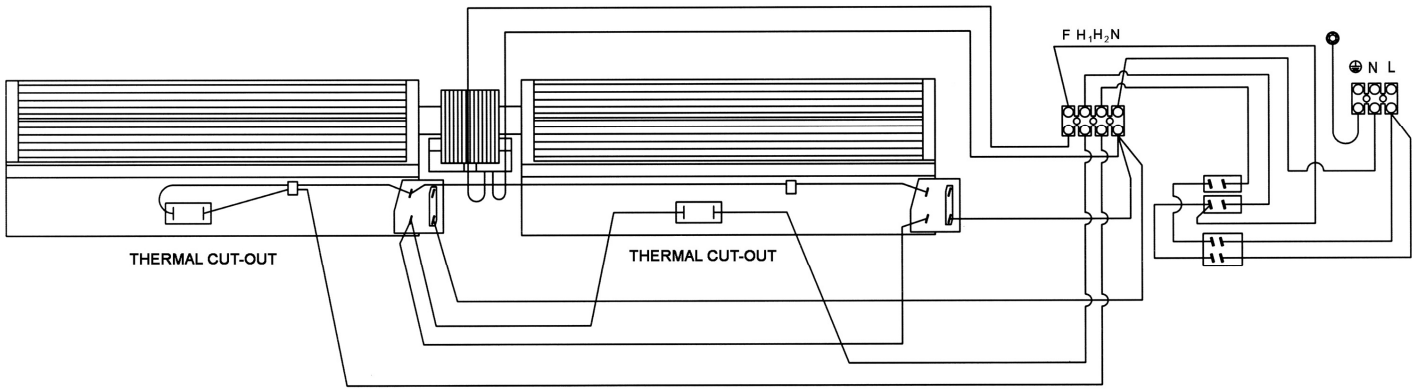

Fig 3 WIRING DIAGRAM

NOTE: This unit is suitable for remote control operation, with the use of remote control switch part no. HE8407. The two independent feeds must be used on 6kW heaters as shown on the diagram.

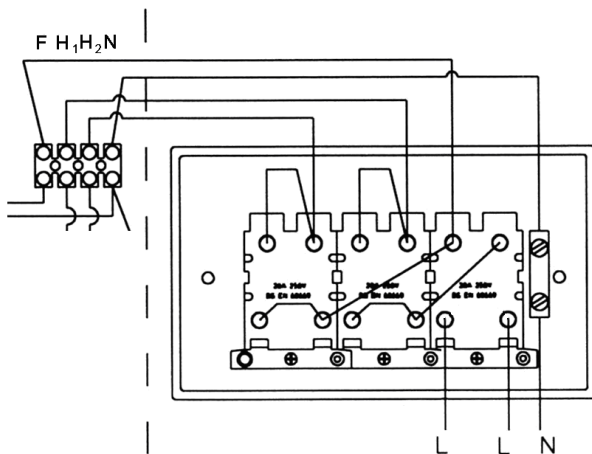

Fig 4 REMOTE CONTROL - HE8407

For safety reasons a sound earth connection must always be made to the unit before it is put to use. The unit should be wired in accordance with IEE Regulations for the Electrical Equipment of Buildings.

NOTE: The unit **MUST** be reliably earthed.

OPERATION

The right hand switch connects the mains supply to the fan motor (giving a cool airflow) and energises the heat control switches.

HEAT CONTROL HE8230

When the centre switch (marked with a single black dot) is depressed the heat output is 1.5kW. When the left-hand switch (marked with two black dots) is depressed the heat output is 3kW. When both switches are depressed the heat output is 4.5kW.

HEAT CONTROL HE7426

When the centre switch (marked with a single bar) is depressed the heat output is 3kW. When the left-hand switch (marked with a single bar) is depressed the heat output is 3kW. When both switches are depressed the heat output is 6kW.

MAINTENANCE

Always ensure that the main external electricity supply is switched off before attending to the servicing of your Claudgen Screen-Zone heater.

To obtain best results from your heater it is necessary to avoid the build up of dust and dirt within the unit and on the air inlet and discharge grills. For this reason regular cleaning is necessary, paying particular attention to the removal of dirt build up on the rotor

blades. A single drop of light oil should be applied to the motor bearing from time to time.

PROTECTION (Thermal Cut-out)

The units are protected in the event of fan failure, or an obstruction of the free airflow, by thermal PTC Self Hold Cut-outs. Having tripped, the PTC cut-out remains open, effectively switching off the heating elements, as long as mains power is available inside the appliance.

TO RESET THE PTC SELF-HOLD CUT-OUT DO NOT ADJUST BY HAND ANY COMPONENTS

- The cut-out is reset by switching OFF mains power to the appliance.
- Allow the appliance to cool for 20 minutes.
- Restart, switch ON the appliance. If the cut-out trips again a qualified electrician should be consulted.

TO REPLACE A SWITCH

- Remove the top cover.
- Release the three fixings which secure the switch bracket to the right hand side of the main case.
- Remove the push-on connectors, noting their position.
- Remove by compressing the plastic retaining tabs, and lifting out the switch.
- Insert the new switch, refit and push on connectors in the correct order, test and reassemble.

TO REPLACE THE FAN HEATER ASSEMBLY

- Remove the top cover.
- Disconnect the internal wiring from the main terminal block and earth stud.
- Release the three fixings which secure the switch bracket to the right hand of the main case.
- Remove the four nuts and washers fixing the fan heater assembly to the back of the case.
- The fan heater assembly can now be eased forward and removed from the heater case.
- Fit replacement fan heater and reassemble in reverse order.

SPARES

It is essential when ordering spares or replacement parts to state the model number and the serial number on the rating place fixed to the top of the unit.

In the interest of progress the Company reserve the right to vary specifications from time to time without notice. The material listed is offered subject to the Company's General Conditions of Sale, a copy of which can be obtained on request.

NOTE: **DO NOT COVER** any of the air inlet or outlet grills, at any time.