



KEY FEATURES & BENEFITS



PROTECTS AGAINST

- E-Coli
- Listeria
- MRSA
- Salmonella
- Odours
- Staining
- Mould & Mildew

SPECIFICATION

Materials	<ul style="list-style-type: none"> • Lid & Ring: Thermoset Plastic (Urea) • Lid Buffers: LDPE • Ring Buffers & Touchpad: TPE • Extended Buffers: Nylon • Hinge Barrel: Stainless Steel • Hinge Bracket Pin & Cover: Stainless Steel
Colours	<ul style="list-style-type: none"> • Lid & Ring: White • Lid Buffers, Ring Buffers & Touchpad: Grey • Extended Buffers: White • Hinge Barrel: Brushed Stainless Steel
Dimensions	<ul style="list-style-type: none"> • 99mm(H) x 371mm(W) x 440mm(D)
Weight	<ul style="list-style-type: none"> • 3.4kg
Features	<ul style="list-style-type: none"> • Made from hard wearing thermoset plastic • Adjustable hinges fit standard oval toilets • Anti-bacterial treated product • Soft close action • Top & bottom fix • Stainless steel, Everfast 'never slip' hinges • Comfortable sitting down position & easy getting up due to additional 55mm seat height

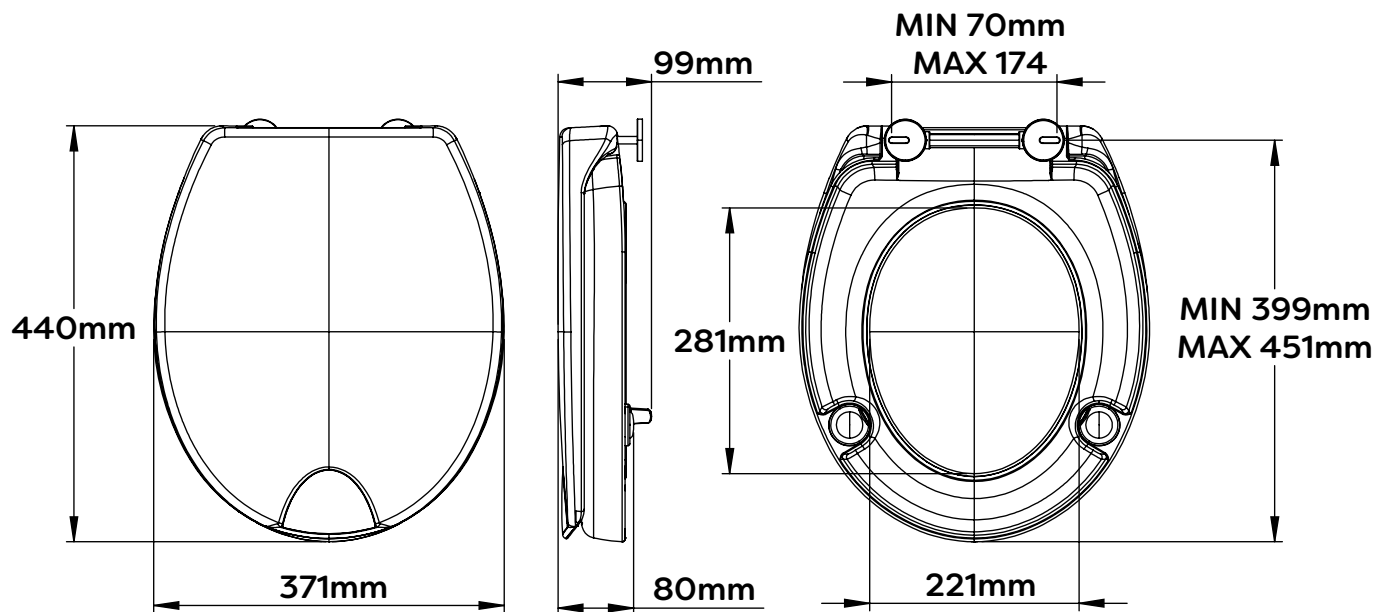

***The adjustable hinges on the toilet seat are suitable for use with BS EN 33 compliant WC pans. BS EN 33 fixing hole centres are between 145mm and 165mm.**

ALL DIMENSIONS ARE NOMINAL

SPECIFICATION

Standards	<ul style="list-style-type: none"> • Minimum grade 9 when assessed using BS EN ISO 10289 after 96 hours Neutral Salt Spray (NSS) testing in accordance with BS EN ISO 9227
Applications	<ul style="list-style-type: none"> • Domestic • Residential • Hotels
Product Care	<ul style="list-style-type: none"> • Clean surfaces with a damp cloth and wipe dry using a soft cloth • Do not use chemical or abrasive cleaners as these may damage the surface finish
Guarantee	<ul style="list-style-type: none"> • Consumer Statutory Rights Apply
Notes	<ul style="list-style-type: none"> • Two extra hinge locking pins and two extra buffer screws are provided