

Contact Details

Please note that some of the contact details on this PDF document may not be current.

Please use the following details if you need to contact us:

Telephone: 0844 879 3588

Email: customer.services@gdcgroup.co.uk

The customer support section of our website also features a wide range of information which may be of use to you and is available 24 hours a day. It includes:

- Operating and installation instructions
- Easy 'How to use' guides for storage heaters
- Service and repairs
- Where to buy our products
- Literature downloads
- Heating requirement calculator

Visit - www.dimplex.co.uk/support

Downflow Fan Heater
Model : FX 20VE



Intertek

(IP22)

08/30042/6 Issue 6

Dimensions

(millimetres)

Model Specification

FX 20VE (High level) 1or 2kW + Electronic, run-back timer

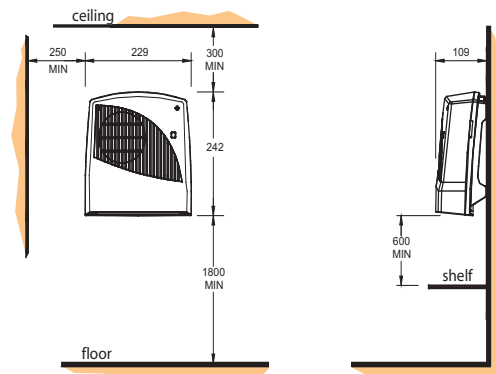

Fig. 1

THESE INSTRUCTIONS SHOULD BE READ CAREFULLY AND RETAINED FOR FUTURE REFERENCE

IMPORTANT SAFETY ADVICE

WARNING - DO NOT USE THIS HEATER IN THE IMMEDIATE SURROUNDINGS OF A BATH, A SHOWER OR A SWIMMING POOL.

DO NOT COVER THE APPLIANCE or place material or garments on it, or obstruct the air circulation around this appliance, for example with curtains or furniture, as this could cause overheating and a fire risk.

DO NOT PLACE AEROSOLS OR OTHER CONTAINERS SUSCEPTIBLE TO HEAT IN THE DIRECT AIRFLOW FROM THE UNIT.

WARNING - Do not operate the heater with the top cover removed. This will trip the thermal fuselink.

THIS HEATER MUST NOT BE LOCATED IMMEDIATELY BELOW A FIXED SOCKET OUTLET.

The appliance is not intended for use by children or other persons without assistance or supervision if their physical, sensory or mental capabilities prevent them from using it safely. Children should be supervised to ensure that they do not play with the appliance.

WARNING – DISCONNECT THE HEATER FROM THE ELECTRICITY SUPPLY BEFORE UNDERTAKING SERVICE OR REPAIR.

WARNING – If the appliance is fitted in a bathroom, a cable outlet will be necessary with the supply to the unit controlled by a double pole switch. The switch if inside the bathroom should be pull cord operated and if outside should be adjacent to the entrance door. The appliance must be mounted so that no part of it can be touched by any person using bath or shower.

THIS HEATER MUST NOT BE OPERATED WITHOUT THE COVER CORRECTLY IN POSITION.

Warning - In order to avoid a hazard due to inadvertent resetting of the thermal cutout, this appliance must not be supplied through an external switching device, such as a timer, or connected to a circuit that is regularly switched on and off by the utility.

General

The heater has a loading of 2kW. It is designed for permanent wall mounting and is suitable for operation on A.C. electricity supply having the same voltage as shown on the rating label.

The heater is fitted with an internally mounted selector switch which on installation of the heater allows a choice of 1kW or 2kW output to suit the dimensions of the room to be heated.

In rooms of less than 9 – 11 cubic m. (350 - 400 cubic ft.) 1kW output should be selected, otherwise nuisance tripping of the thermal overload cut-out may occur.

NOTE : THE SWITCH HAS BEEN FACTORY SET FOR 1kW OPERATION. IF ADDITIONAL OUTPUT IS REQUIRED, 2kW CAN BE SELECTED ON INSTALLATION.

SUPPLY CABLE IS NOT SUPPLIED WITH THIS APPLIANCE AND IT SHOULD THEREFORE BE INSTALLED BY A COMPETENT ELECTRICIAN IN ACCORDANCE WITH THE LATEST IEE REGULATIONS.

Safety

Cut-Out

For your safety, this appliance is fitted with a thermal cut-out. In the event that the product overheats, the cut-out switches the heater off automatically.

To bring the heater back into operation, remove the cause of overheating, then turn off the electrical supply to the heater for a few minutes.

When the heater has cooled sufficiently reconnect and switch on the heater.

Fuse Link

A thermal fuse link is provided as an added safety feature. If the fuse link operates and opens circuit it is the result of abnormal overheating within the appliance.

To ensure the future safe operation of the heater please contact Dimplex Customer Services.

Installation

WARNING: Minimum clearances must be adhered to when mounting the heater.

Before undertaking installation work, ensure the electricity supply is disconnected from any relevant fixed wiring. Supply cable is not supplied with this appliance and it should therefore be installed by a competent electrician in accordance with the latest IEE wiring regulations.

The supply circuit must be adequate for the input of the appliance and must be protected with a 13A fuse.

A suitable termination to the fixed wiring of the premises must be provided adjacent to the final position of the appliance through a double pole switch having a contact separation of at least 3mm in all poles.

Installation Procedure

It is essential to observe minimum wall mounting clearances - see Fig. 1.

The appliance should be fitted horizontally, with the cable entry at the top and grille at the bottom. It must be mounted not less than 1800mm above the floor with a clearance of at least 600mm to any shelf or projecting surface below the heater and not less than 300mm below the ceiling or other projecting surface. It must also be not less than 250mm from an adjacent projecting surface. For most effective heating performance the heater should be mounted at the minimum height : i.e. 1800mm above the floor.

Care must be taken to ensure that when in use, the air stream is not obstructed by a high shelf or cabinet.

The appliance is secured to the wall with three screws, two through keyhole slots and one through a centrally positioned lower hole to hold the appliance firmly in position (see Fig. 2).

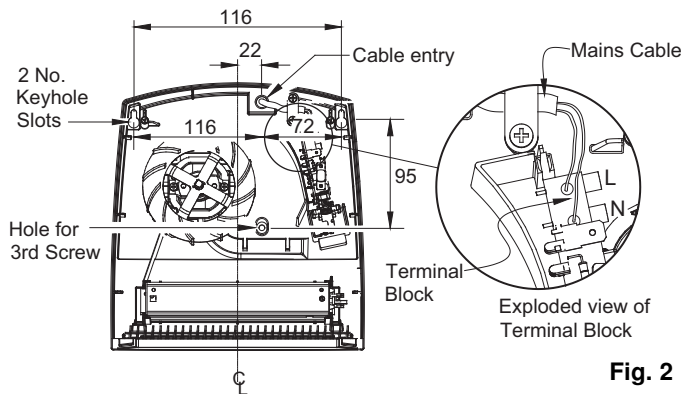

Fig. 2

1. Remove the top cover from the appliance by removing the two screws securing the top cover and hinging it back.
2. Mark the position of the keyhole slots on the wall and drill and plug for the two suitable screws.
3. Partially insert the two screws, then hang the appliance on these screws and mark the position of the lower centrally positioned screw.
4. Remove the appliance and drill and plug for the third screw.
5. Remount the appliance on the wall, ensure that it is horizontal and fix in position by tightening all three screws.
6. Feed the supply cord or wires through the inlet at the top rear of the appliance leaving sufficient free length to connect to the terminal block.
7. Make electrical connections to the terminal block ensuring that the live connection is made to the terminal marked 'L' and the neutral connection to the terminal marked 'N' (see Fig. 2 exploded view).
8. Operate the selector switch to provide either 1kW or 2kW output.
9. Replace the top cover and screws.

The appliance is now ready for use and the electricity supply can be reinstated.

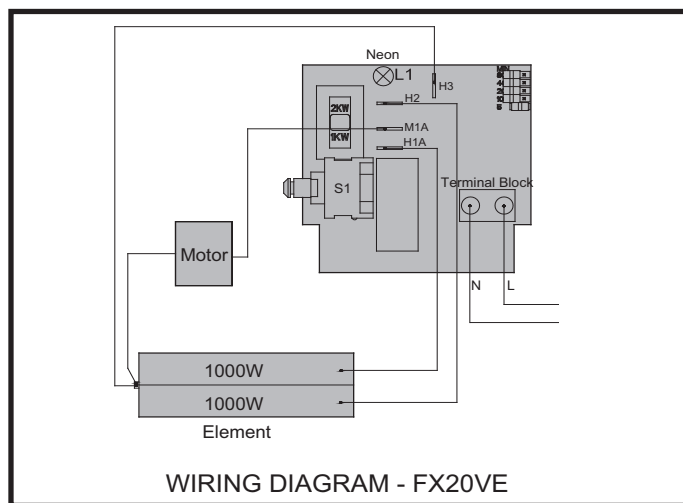

Fig. 3

Controls

The **cut-out** is a safety device which switches off the heater and fan if for any reason the appliance overheats - see 'Safety'.

The **thermal fuse link** is provided as an added safety feature, and operates to open circuit if there is abnormal overheating within the appliance. The operation of these safety devices is described under 'Safety'.

CE The product complies with the European Safety Standards EN60335-2-30 and the European Standard Electromagnetic Compatibility (EMC) EN55014, EN60555-2 and EN60555-3. These cover the essential requirements of EEC Directives 2006/95/EC and 2004/108/EC

Dimplex UK Ltd.
Millbrook House
Grange Drive
Hedge End
Southampton
Hampshire. SO30 2DF

UK customer help line 8.00am–5.00pm Mon-Fri and 8:30am-1.00pm Sat (October-March)

Technical Services: Tel. 0844 870 3588
Fax. 0844 879 3582
e-mail technical.services@dimplex.co.uk

Republic of Ireland Tel. 01 842 4833

[c] Dimplex UK Limited

All rights reserved. Material contained in this publication may not be reproduced in whole or in part, without prior permission in writing of Dimplex UK Limited.

This model has a **run-back timer** which can be set on a run time of 5 – 155 minutes. This can be adjusted by removing the top cover and moving the jumpers on the timer, e.g. to run the timer for 65 mins. you leave the 5, 20 and 40 min jumpers in the closed position (i.e. the closed position is when the jumper covers the two pins on timer), and move the remaining jumpers to open position or on one pin only, which provides no contact between pins. (see Fig. 4 for setting for 65 mins)

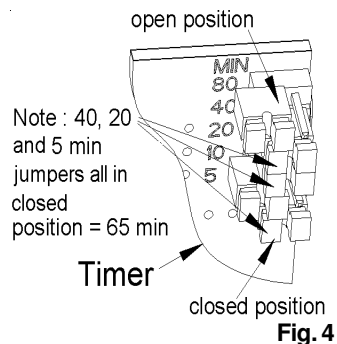

Fig. 4

Note: The run-back period defaults to 15 minutes when all jumpers are in the open position.

At the end of a timer run-back period, the appliance can be restarted by pulling the cord twice; the red neon light will extinguish after the first pull, and will light up again after the second pull.

Cleaning and User Maintenance

WARNING

BEFORE UNDERTAKING CLEANING OR MAINTENANCE WORK ON THE APPLIANCE DISCONNECT THE ELECTRICITY SUPPLY BY SWITCHING OFF AT THE ADJACENT DOUBLE POLE SWITCH.

The outside can be cleaned by wiping it over with a soft damp cloth and then dried. Do not use abrasive cleaning powders or furniture polish as this can damage the surface finish.

Ensure that dust or fluff does not accumulate inside the heater as this could lead to overheating of the element. Use a vacuum cleaner to remove any fluff which does accumulate.

Recycling

For electrical products sold within the European Community. At the end of the electrical products useful life it should not be disposed of with household waste. Please recycle where facilities exist. Check with your Local Authority or retailer for recycling advice in your country.

After Sales Service

If this product appears damaged when first received or does not function correctly contact us by e-mail aftersales@dimplex.co.uk or ring 0844 879 35 88 and we will be able to help. For ROI please phone 0184248333.

Do Not Return the product in the first instance as this may delay us providing you with a satisfactory service.

ACCIDENTAL DAMAGE IS NOT COVERED UNDER THE WARRANTY.

Your product is guaranteed for two years from the date of purchase. Within this period, we undertake to repair this product free of charge provided it has been installed and operated in accordance with these instructions.

Should you require assistance with this product please go to www.dimplex.co.uk and click on "Customer Support" or e-mail us at aftersales@dimplex.co.uk

Alternatively ring our contact centre on 0844 879 35 88 (UK only). This is a Lo-call no. from a BT landline - other providers including mobile phones may charge you more. For ROI please phone 01 842 4833.

To assist you, we will need the following information: model number & serial no (these can be found on the product), nature of the fault & date of purchase. **Please retain your receipt as proof of purchase.** Your rights under this guarantee are additional to your statutory rights, which in turn are not affected by this guarantee.

Spares can be purchased on line, go to www.dimplex.co.uk/outlet_store