



Premium Quality
German

*Radiators
and Panel
Heaters*

ehc

the electric heating company

Quality solutions for the ultimate heating performance



The EHC Combination Electric radiators have been designed using the latest technology to create an elegant solution for all hard to heat situations. They can be installed in almost any location due to the flexibility of the product.

The range has been developed to provide an adaptable solution for electric heating in Domestic properties, Conservatories, Holiday homes, Offices and any other central heating situation.

Our unique patented 'Magmatic' heating tablets provide the source for the radiator. Whilst the radiator is classed as a 100% efficient Direct Acting appliance, the heating tablets provide partial storage to prolong your heating comfort and to reduce running costs. The radiator has a robust body which incorporates a

spot welded high fin surface area to ensure that there are no expansion or contraction noises during the heating cycle. The high fin design boasts 6 times the normal radiator surface area to provide a balance of Convection and Radiant heat for your added comfort.

The radiators can be simply plugged in to a standard socket or hard wired to an existing spur connection. The range has the flexibility of being wall mounted or free standing on castors or feet.

For added versatility we can supply conservatory radiators which are also ideal for use below windows with low sills.



All EHC Combination Radiators and Panel Heaters are supplied with an electronic, highly accurate thermostat, as shown above. Different options are available. In addition to the above we also supply Radio Frequency radiators which provide all the benefits of the standard version however the control wiring is eliminated. These models can be controlled by our TPod and Tbasic RF thermostat.

Manual TEI I

setting the *standard* in electric heating

Furthermore we also supply EHC radiators with an integral TDI digital thermostat that can be programmed 24 hours, 7 days a week. All EHC radiators are manufactured in Germany to the highest safety and quality standards. Each radiator is CE Marked and ENEC Marked and carries all the necessary European Approvals.

All EHC radiators are fully checked and tested prior to leaving the factory and are packed fully assembled complete with wall hanging brackets and full Quality Certification.

We hope that you find the superior products within this brochure of interest and we look forward to being of assistance to you in the near future.



1kW IPX4

living with *electric*
combination radiators



1kW



500w/800w

The EHC Electric Combination Radiators have been accepted as a practical modern solution to outdated, inefficient electric storage heaters.

Their success is due largely to the following features and benefits:

- No boiler, plumbing or pipework required
- Ease of Installation
- Manual, radio frequency or digitally integrated thermostat
- Safe, clean and easy to operate
- Fully controllable by either manual or digitally controlled (TDI) thermostats.
- Slimline Radiators are 70mm deep
- Various outputs and sizes are available from 500w - 2.4kW
- No maintenance required 100% efficient
- Supplied with wall fixing brackets
- Castors, feet stands or radiator supports can be ordered as optional extras
- Radiators are supplied fully assembled with a UK plug and 1.5m of cable
- All radiators are powder coated in a white high quality enameled finish



As our products are of such superior quality we are proud to offer a *15 year warranty* on our radiators and a *2 year warranty* on the electronics across our full range of EHC Electric Combination Radiators.



2kW/2.4kW



close your eyes and *dream*
in total comfort



1.5kW

standard range of *radiators*



No carbon monoxide risk and with a constant comfortable background temperature, you are assured of a warm and pleasant nights sleep.

All of the EHC "Standard" sized Combination Radiators are 630mm high and only 70mm in depth. (please refer to sizing chart on page 23).

All Radiators are supplied with wall mounting brackets as standard. Radiator supports, feet or castors can be supplied as optional extras.



2kW/2.4kW

1.5kW

1kW

500w/800w

tall orders
in the kitchen

500w/800w

2.2kW

tall reputation with high performance whatever your space

The range has been developed to accommodate the smallest easy-to-heat room to the larger hard-to-heat room. Should you select our products you will be highly impressed by the performance and effectiveness of the electric radiators.

We currently sell the radiators as heating solutions to a wide range of markets which include the following:

- Domestic Properties
- Properties with no access to natural gas
- Conservatories and Sunrooms
- Social Housing Contracts
- Holiday homes, Parkhomes and Caravans
- Hotels and Pubs
- Schools
- Offices
- Portable Offices
- Temporary Heating purposes



1.2kW





enjoy the outside *inside*
with Conservatory radiators

1.6kW

To compliment your existing heating system EHC have produced a selection of low profile electric radiators, all 340mm high. Ideal for use in conservatories, sunrooms and rooms with low window sills, all EHC Radiators are supplied with wall mounting brackets.

With the option of floor standing or castors you have the ability to place your radiator anywhere within your conservatory.

This practical range can be controlled by Manual, Radio Frequency or Integrated Digital Thermostats.

Various thermostat options available.



Manual TEI I
electronic thermostat



TDI electronic
7 day programmable
thermostat

radiator fixing accessories

The EHC Radiator range is fully versatile and portable for locating in whatever space you require heat.

Installation kits for wall fastening are supplied as standard.

Radiators can also be mounted on feet stands or castors for ease of movement. Feet supports are also available if required.

(Subject to lead time all EHC Radiators are available in any of the 900 RAL colours.)



Installation kit for wall fastening



Radiator Feet supports



Feet stands



Castors

1.2kW IPX4



make a splash with
bathroom *radiators*



600w IPX4



- IPX rated models

All EHC Bathroom Radiators, up to an output of 1.2kW, are IPX4 rated and therefore tested and approved for use in all bathroom situations.

Options range from standard radiators to tall radiators with towel hanging rails and a choice of chrome towel rails.

Please consult a qualified electrician before installing an IPX rated radiator in any bathroom or wet room location.

Water heating products, including hot water cylinders are also available from EHC. Further information is available on request.



the engineering behind the

quality

Convected heat

Radiant heat

An equal combination of radiant and convected heat gives a constant temperature throughout the room.

Our unique combination radiators are designed to store the heat directly into the Magmatic Heat-Retention Tablets, without any loss of energy.

The metal ribs on the radiator form a six times greater surface area than a normal radiator. As a result of this, approximately 50% radiant heat as well as 50% convected heat is created, to give a much more constant temperature throughout the room, from floor to ceiling.

EHC Radiators are unique due to the metal ribs being individually spot welded which prevents any noise during the heating up and cooling down cycle.

When the EHC Radiators have achieved their required temperature the thermostat will cut the power to the Radiator. The Radiator will continue to provide heat, (that has been stored in the Magmatic tablets), for up to 45 minutes with no further use of electricity. The Radiators will use approximately 20 – 30 minutes of electricity per hour, depending upon on the building fabric and the outside temperature.

The heating conductors are produced from high quality chrome-nickel steel (resistant to scaling up to 1100 °C) which are moulded into the Magmatic tablet, reducing the risk of corrosion.

The contacts inside the radiators are protected with heat shrinkable insulated sleeves to ensure optimum safety. Multiple thermocouples within each radiator provide overheat protection for additional safety.

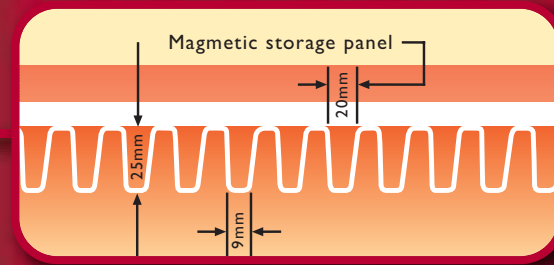

Outside - High Fin Surface area



Inside - **Magmatic** heat retention tablets

EHC Control Box –

This method of control is suitable for standard models where multiple radiators are required. In addition to the Control Box you will also require a Single Channel Heat Pack (see schematic).

EHC Control Box



EHC Control box



Single Channel Heatpack

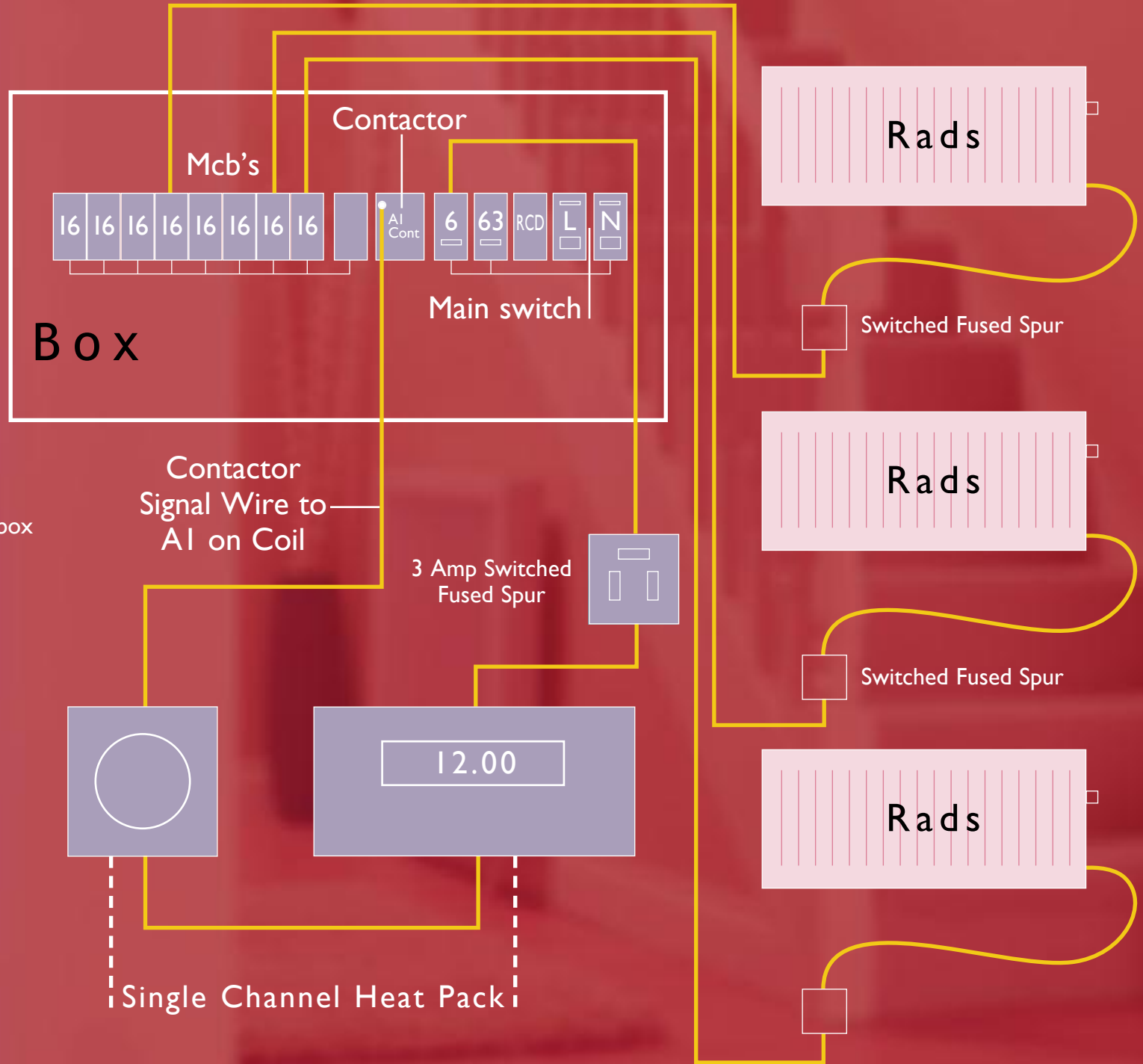

Typical Radiator Installation

(Neutral wiring has not been shown for clarity reasons)
Control Wiring: 1.0 mm Twin and earth

Radiator Wiring: 2.5 mm Twin and earth
All Wiring must comply with current IEE Regulations
17th edition: 1st July 2008 - BS 7671

For illustration purposes only

Technical Specification

Model No.	Description	Colour	Rating BTU's	DIMENSIONS			
				Width (mm)	Height (mm)	Depth (mm)	Weight (kg)
STANDARD RADIATORS							
EH500.38.63	500watt EHC ELECTRIC RADIATOR	White	1706	380	630	70	22
EH800.38.63	800watt EHC ELECTRIC RADIATOR	White	2730	380	630	70	22
EH1000.68.63	1000watt EHC ELECTRIC RADIATOR	White	3412	680	630	70	36
EH1200.68.63	1200watt EHC ELECTRIC RADIATOR	White	4094	680	630	70	36
EH1500.98.63	1500watt EHC ELECTRIC RADIATOR	White	5118	980	630	70	50
EH1800.98.63	1800watt EHC ELECTRIC RADIATOR	White	6142	980	630	70	50
EH2000.128.63	2000watt EHC ELECTRIC RADIATOR	White	6824	1280	630	70	62
EH2400.128.63	2400watt EHC ELECTRIC RADIATOR	White	8189	1280	630	70	62
CONSERVATORY RADIATORS							
EH500.68.34	500watt EHC ELECTRIC CONSERVATORY RAD	White	1706	680	340	70	21
EH1000.85.34	1000watt EHC ELECTRIC CONSERVATORY RAD	White	3412	850	340	70	24,5
EH1600.128.34	1600watt EHC ELECTRIC CONSERVATORY RAD	White	5459	1280	340	70	34,5
EH2000.158.34	2000watt EHC ELECTRIC CONSERVATORY RAD	White	6824	1580	340	70	38
TALL RADIATORS							
EH1200.38.124 IPX4R	1200watt EHC ELECTRIC RADIATOR (with rails)	White	4094	380	1240	70	38
EH1200.38.124	1200watt EHC ELECTRIC RADIATOR	White	4094	380	1240	70	35
EH1800.55.124	1800watt EHC ELECTRIC RADIATOR	White	6142	550	1240	70	58
EH2200.68.124	2200watt EHC ELECTRIC RADIATOR	White	7506	680	1240	70	72
TOWEL RAILS							
2003.06WE (WHITE RAILS)	1200watt EHC ELECTRIC TOWEL RADIATOR	White	4094	640	1020	140	33
2003.06WEC (CHROME RAILS)	1200watt EHC ELECTRIC TOWEL RADIATOR	White	4094	640	1020	140	33
BATHROOM RADIATORS (IPX4)							
EH600.38.63IPX4	600watt EHC ELECTRIC BATHROOM RADIATOR	White	2047	380	630	70	22
EH1000.68.63IPX4	1000watt EHC ELECTRIC BATHROOM RADIATOR	White	3412	680	630	70	36
CONTROLS & ACCESSORIES							
CAST/I FEET/I RADSUPP S/PACK/I TPod TBasic TCentral E10SS EHC 6 Way EHC 10 Way	RADIATOR CASTORS RADIATOR FEET RADIATOR FEET SUPPORTS SINGLE CHANNEL HEATPACK 7 DAY DIGITAL PROGRAMMABLE THERMOSTAT R/F THERMOSTAT TCENTRAL CONTROLLER SUPREME SAVER HOT WATER CONTROLLER 6 Way CONTROL BOX 10 Way CONTROL BOX			The above Model Nos. are for EHC Standard Radiators with TEI I control. Following details should be prefixed to the Manual Model Number when ordering a different type of control: TDI DTE I RF See below for examples.			

The following is a typical example when ordering an EHC Radiator: EH1000.68.63 (This radiator has a manual standard TEI I control). EH1000.68.63TDI (This radiator has an integral TDI control for time & temperature). EH1000.68.63DTEI I (This radiator has an integral digital control feature). EH1000.68.63RF (This radiator has an inbuilt radio frequency receiver).

Visage panel *heat*

- Outputs up to 2.0kW
- TDI - In-built Digital Time & Temperature Thermostat
- Patented heat retention tablet delivers greater energy efficiency than a traditional convector heater
- The high quality aluminium heating element has a large surface area that warms up quickly and distributes heat in an effective and efficient way.
- Unique Design and features ensure low surface temperatures on the radiator
- Twin overhear protection
- Wall mounted or free standing option available
- IP 24 splash proof for use in bathrooms and wet areas
- This slimline range is 68mm deep

5 Year Guarantee



2.0kW

Twin overhear protection

User friendly Digital Thermostat

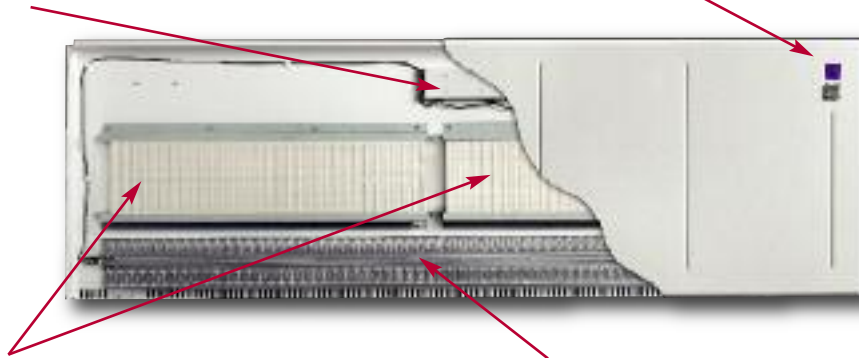

Patented heat retention tablets made from 100% bio-degradable ceramic material that can potentially reduce electricity use by up to 10% compared to traditional convector heaters.

Up to 2.0kW high quality aluminium element.

ter modern, slim and high efficiency



- TDI Digital programmer and thermostat

The clean, contemporary styling of these slimline heaters allows them to blend into any room in your home. Perfect where space is at a premium.

They can be wall mounted or free standing. The perfect heating solution throughout the home.

Visage Heater Dimensions (mm)

	W		H		D
1.0kW	750	x	450	x	68
1.2kW	750	x	450	x	68
1.5kW	1050	x	450	x	68
2.0kW	1050	x	450	x	68



1.5kW



1.0kW

Premium Quality German
*Radiators and Panel
Heaters*



the electric heating company

**Exclusive Distributor for
United Kingdom**

The Electric Heating Company Limited
Block 5 Unit 40 Third Road
Blantyre Industrial Estate
Blantyre G72 0UP United Kingdom
Tel: 01698 820533 Fax: 01698 825697
Email: info@electric-heatingcompany.co.uk

www.electric-heatingcompany.co.uk

Company Registration No. 289495

Worldwide distribution
network

**Head Office and Production
in Germany**

**Austria
Australia
Belgium
Bulgaria
Cyprus
Czech Republic
France
Germany
Greece
Ireland
Italy
Kuwait/Middle East
Netherlands
New Zealand
Poland
Romania
Russia
South Africa
Slovakia
Spain
South Africa
Taiwan
Turkey
Ukraine
United Kingdom**



- Europe-wide applicable
- Safety tested
- Production controlled

The Electric Heating Company delivers premier heating products across the UK. Our range of EHC Combination Radiators are produced in Germany and comply with the appropriate standards of the European Union and Certificate Institutes.



The Keymark E24 is the equivalent of the BEAB mark in the U.K.

Disclaimer – All figures quoted are correct at the time of printing and may be subject to change

