

TECHNICAL DATA SHEET

Product Code: 185303

Product Description: Dehumidifier 16L

Product Image:



Product Specification

Dimensions: 350*235*490mm

Materials: ABS Plastic, metal

Fitting: Wheels, Water hose

Approvals: CE (LVD and EMC)

Additional Information

Features & Benefits:

- With wheels
- Continuous drainage
- With handle
- Visible water level

TECHNICAL DATA SHEET

Technical Drawings -

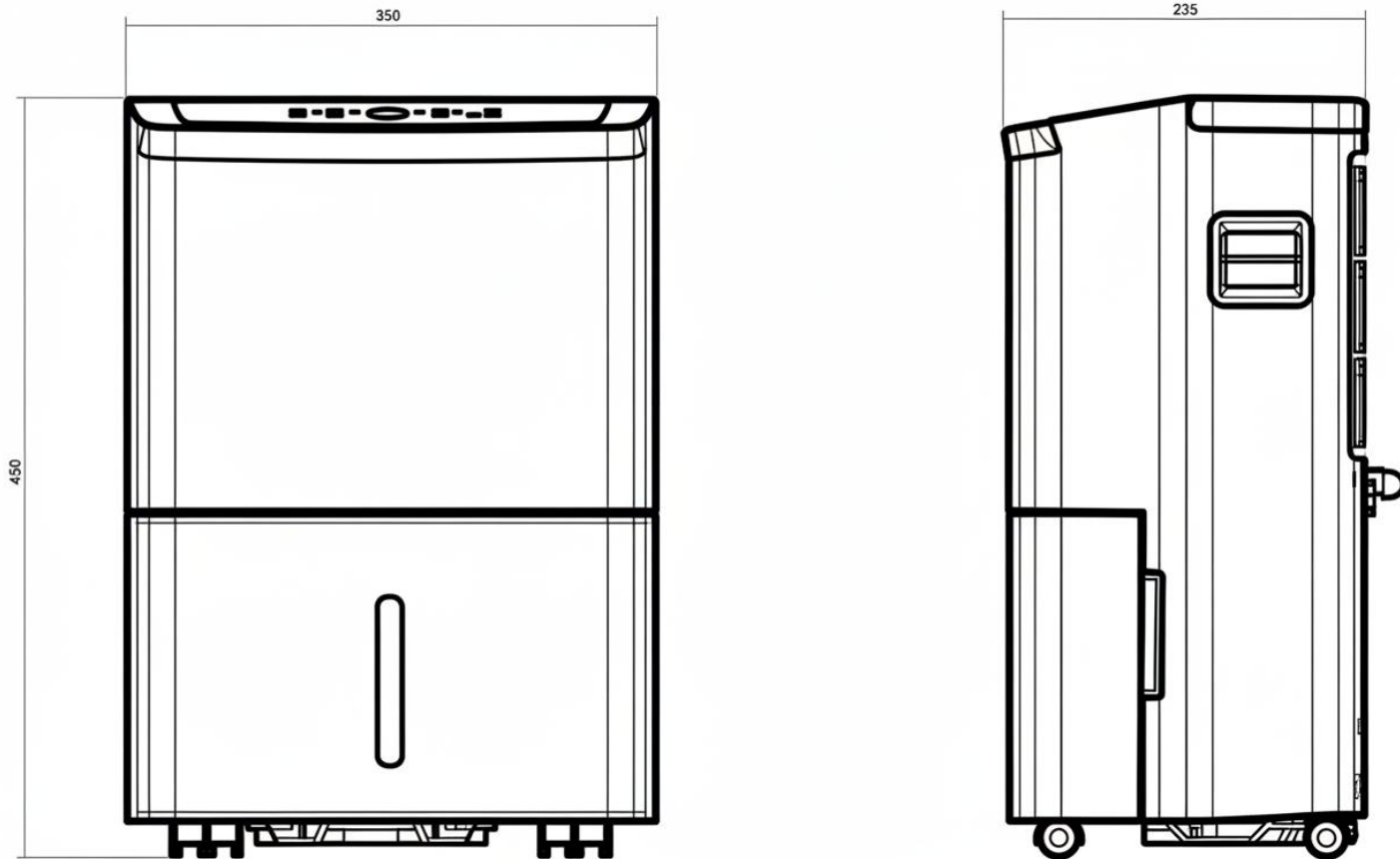

Guarantee: only required if an extended warranty is offer with details on what is covered

EU GPSR Single Point of Contact: Product.compliance@highbournegroup.co.uk