

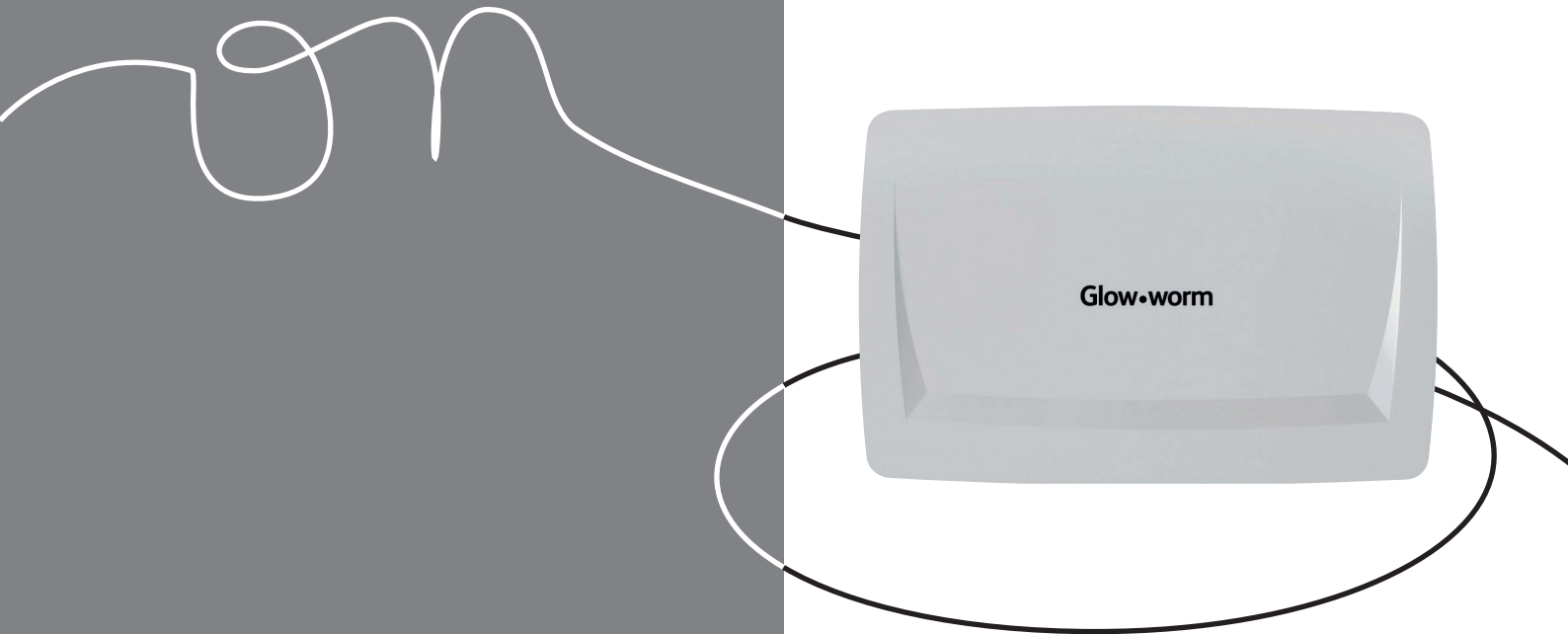

**Glow•worm**  
The energy you need

## Installation and Servicing

Smart Wiring Center 2





# TABLE OF CONTENTS

1	Notes on the documentation .....	2
	1.1 Symbols used .....	2
	1.2 Observe other applicable documents .....	2
	1.3 Storing documents.....	2
	1.4 Validity of the instructions.....	2
2	Safety.....	2
	2.1 General safety advices.....	2
	2.2 Intended use.....	3
	2.3 Rules and regulations.....	3
	2.4 CE label .....	4
3	Description of the product .....	4
	3.1 Product Overview .....	4
	3.2 Product structure .....	5
	3.3 Type designation and serial number .....	11
	3.4 Data plate description .....	11
4	Mounting and installation .....	11
	4.1 Preparing the mounting and installation .....	11
	4.2 Mounting the product.....	11
	4.3 Electrical Installation.....	12
5	Commissioning .....	14
	5.1 Filling.....	14
	5.2 Venting .....	14
	5.3 Switching on.....	14
	5.4 Multizone specific adjustment .....	14
	5.5 Restart and check.....	14
6	User information .....	14
7	Maintenance.....	14
	7.1 Trouble-shooting.....	14
	7.2 Main supply cable .....	15
8	Decommissioning .....	15
9	Recycling and disposal .....	15
	9.1 Recycle the packaging .....	15
	9.2 WEEE: Recycle or dispose the product and its components.....	15
10	Guarantee and customer service .....	16
11	Technical data.....	16





## 1 Notes on the documentation

### 1.1 Symbols used

The symbols used in the text are explained below:

Symbol	Explanation
	Symbol that denotes useful tips and information
•	Symbol for a required action

The warning notes are classified in accordance with the severity of the possible danger using the following warning signs and signal words.

Warning symbol	Signal word	Explanation
	Danger	Immediate danger to life or risk of severe personal injury.
	Danger	Risk of death from electric shock.
	Warning	Risk of minor personal injury.
	Caution	Risk of material or environmental damage.

### 1.2 Observe other applicable documents

- Observe absolutely all operating and installation instructions enclosed with the product, for the various parts and components of the system.

### 1.3 Storing documents

- Pass these instructions and all other applicable documents to the system user.

The system user should retain these instructions so that they are available when required.

### 1.4 Validity of the instructions

These instructions apply exclusively to:

Liste type	
Product	Article number
Smart Wiring Center 2	0020135101

## 2 Safety

All electrical work performed on the equipment must be carried out by a qualified engineer or Glow-worm Group Service engineer.

This equipment must only be installed by a qualified engineer, to ensure that the applicable regulations and rules are adhered to.

When work on the appliance is completed, perform an operational test and check for safety in accordance with BS EN 7671.

### 2.1 General safety advices

- Before to read this chapter, also read the general safety advice of the operating instructions.

#### 2.1.1 Danger to life by electric shock

Touching live connections can cause serious personal injury.

- Before carrying out any work on the product, switch off the power supply.
- Secure the power supply against being switched on again.

#### 2.1.2 Danger to life by escaping gas

Incorrect installation can cause leakages and explosion.

- Make sure there are no stresses in the gas line.
- Correctly position the seals.
- Observe the legal directives and the local regulations for gas supply companies.

#### 2.1.3 Danger to life by escaping flue gases due to unlocked openings

Flue gases can escape through openings in the flue pipe. Inspection chambers in the flue gas pipe can be opened.

- Open inspection chambers only if you are a competent person.
- Close all inspection chambers before start-up.

#### 2.1.4 Danger to life due to missing or not properly working safety devices

Missing safety devices can cause life-threatening scalding and other injuries, for example by burst pipes.

The information contained in this document do not show all schemes required for a professional installation of safety devices.

- Install the necessary safety devices in the system.
- Inform the user about the function and location of safety devices.
- Observe the relevant national and international laws, standards and guidelines.

### 2.1.5 Danger of scalding due to the hot water!

- There is a danger of scalding at the hot water draw-off points if the hot water temperatures are higher than 60°C. Young children and elderly persons are particularly at risk, even at lower temperatures.
- Select the temperature so that nobody is at risk.
- Explain to the user how to select the best temperature taking into account the risk of scalding and the risk of legionella.

### 2.1.6 Danger due to improper use

Nonprofessional work on the product can cause damage to the installation and as a consequence even personal injury.

- Only work on the product if you are a competent person.

### 2.1.7 Risk of material damage by additives in the heating water

Frost and corrosion protection agents can cause changes to seals, noise during heating mode and may lead to other consequential damage.

- Do not use any unsuitable frost or corrosion protection agents.

### 2.1.8 Risk of material damage caused by unsuitable tools

The use of unsuitable tools or improper use thereof may cause damage, such as gas or water leaks.

- When tightening or loosening threaded connections, always use suitable opened spanners, but do not use pipe wrenches, extensions, etc.

### 2.1.9 Risk of structural damages by escaping water

Incorrect installation can cause leakages.

- Make sure there are no stresses in the hydraulic lines.
- Correctly position the seals.

## 2.2 Intended use

#### *State-of-the-art*

The product is a state-of-the-art product which has been constructed in accordance with recognised safety regulations. Nevertheless, there is still a risk of injury or death to the user or others or of damage to the product and other property in the event of improper use or use for which it is not intended.

#### *Intended use*

The product is intended as a heating appliance for sealed central heating installations (heating / cooling and hot water) to consume a minimum of energy to optimize the energy bill.

#### *Applicable documents*

Intended use includes the following:

- observing the included operating, installation and maintenance instructions for this product and any other parts and components of the system
- installing and fitting the product in accordance with the product and system approval
- complying with all of the inspection and maintenance conditions listed in the instructions.

#### *Moisture and water splashes*

It will be necessary to install the unit in a location where it will not be exposed to moisture or water splashes. Observe the electrical protection (EP) contained in the technical data.

#### *Unintended use*

Any other use than the use described in the instructions at hand or any use extending the described use is not intended.

Any direct commercial or industrial use is also deemed to be improper.

## 2.3 Rules and regulations

### 2.3.1 Statutory requirements

Installation of this appliance falls within the scope of the Building Regulations 2010 (Part G). This requires that the installation of an unvented system should be notified to the local authority Building Control Department and the work must be carried out by a competent person as defined in the approved document G3.

Where no British Standards exists, materials and equipment should be fit for their purpose and of suitable quality and workmanship.

The installation of this control unit must be carried out by a competent person approved at the time by the Health and Safety Executive and in accordance with the rules in force in the countries of destination.

Manufacturer's instructions must not be taken as overriding statutory requirements.

During the installation and activation of the control unit, the decrees, directives, technical regulations, standards and clauses hereafter must be complied with in the versions that are currently in force.

- IEC 60730-2-9 Automatic electrical controls for household and similar use: Particular requirements for temperature sensing controls
- IEC 60730-1 Automatic electrical controls for household and similar use: Common requirements
- IEC 60335-1 Specification for safety of household and similar electrical appliances
- Directive on the restriction of the use of certain hazardous substances in electrical and electronic equipment (2002/95/EC)

- Regulation concerning the Registration, Evaluation, Authorisation and Restriction of Chemicals (REACH, No. 1907/2006)

In GB, the installation of the control unit must comply with the requirements of the current issue of BS6798 and be carried out by a competent person approved at the time by the Health and Safety Executive and as described in the following regulations:

- The manufacturer's instructions supplied.
- The Gas Safety (Installation and Use) Regulations.
- The appropriate Building Regulations (UK), The Building Regulations (Scotland), The Building Regulations (Northern Ireland).
- The Water Supply (water fittings) Regulations 1999 and water byelaws 2000, Scotland.
- The Health and Safety at Work Act, Control of Substances Hazardous to Health (COSHH).
- Any electrical work must conform to BS7671 and part P of the building regulations where applicable.

Where no specific instructions are given, reference should be made to the relevant British Standard Code of Practice.

In IE, the installation must be carried out by a competent person approved at the time by the Health and Safety Executive and installed in accordance with the current edition of I.S.813 "Domestic Gas Installations", the current Building Regulations and reference should be made to the current ETCI rules for Electrical Installation.

GB: the following Codes of Practice apply: BS4814, BS6798, BS5440 Part 1 and 2, BS5546 Part 1, BS5449, BS6891, BS6700, BS7074 Part 1 and 2, BS7593, BS7671.

IE: I.S.813, BS5546, BS 5449, BS 7074, BS 7593.

NOTE: For further information, see the current issue of the Building Regulations, approved document L1 (in the UK) and the following current issues of:

- 1) Central heating system specification (CheSS) and
- 2) Controls for domestic central heating system and hot water. BRECSU.

Benchmark places responsibilities on both manufacturers and installers. The purpose is to ensure that customers are provided with the correct equipment for their needs, that it is installed, commissioned and serviced in accordance with the manufacturer's instructions by a competent person approved at the time by the Health and Safety Executive and that it meets the requirements of the appropriate Building Regulations. The Benchmark Checklist can be used to demonstrate compliance with Building Regulations and should be provided to the customer for future reference.

Installers are required to carry out installation, commissioning and servicing work in accordance with the Benchmark Code of Practice which is available from the Heating and Hotwater Industry Council who manage and promote the Scheme.

Visit [www.centralheating.co.uk](http://www.centralheating.co.uk) for more information.



## 2.3.2 Domestic Hot Water

All domestic hot water circuits, connections, fittings must be in accordance with the relevant standards and water supply regulations.

## 2.3.3 Electrical Supply

The control unit **MUST** be earthed. All system components shall be of an approved type and all wiring to current I.E.E. wiring regulations. External wiring must be correctly earthed, polarised and in accordance with the relevant standards.

In GB, this is BS 7671.

In IE, this is the current edition of ETCI rules.

The control unit **MUST** be connected to a permanent 230V ac, 50Hz supply.

## 2.4 CE label

The CE mark indicates that the products described in these instructions are in compliance with the following directives:

- European Directive Num. 2004-108 of the European Parliament and the Council regarding electromagnetic compatibility
- European Directive Num. 2006-95 of the European Parliament and the Council regarding low voltage.

## 3 Description of the product

### 3.1 Product Overview

The control unit provides a system solution which permits eBUS controllers to be combined with room thermostats, valves, multizone heating and domestic hot water cylinder systems. There are 2 functional modes that can be selected with the rotary switch :

- Multizone mode (position 0) with SWC2 functions.
- Monozone mode (position 1) with SWC1 functions.

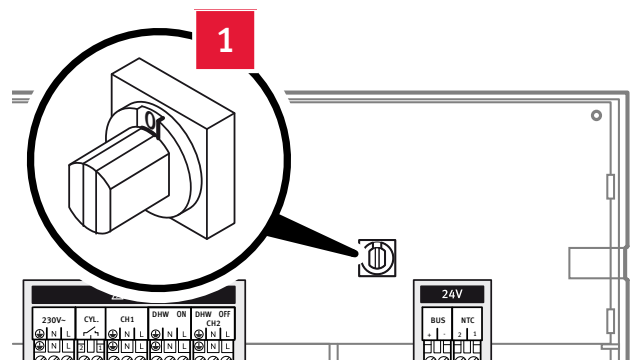

Legend

- 1 Rotary switch

## 3.2 Product structure

### 3.2.1 Monozone operation mode

The Monozone operation mode is compatible with:

- Climapro/Climapro<sub>2</sub> RF and Climapro<sub>1</sub>/Climapro<sub>1</sub> RF range
- System and open vent boiler

It allows the “Climapro or Climapro<sub>2</sub> RF” to communicate with the traditional 230V zone valves and DHW storage cylinder. Information about the heat required by the cylinder is communicated to the heating appliance. The heating appliance (boiler) then decides whether a hot water request has to be fulfilled and sends a signal to position the 230V zone valves.

The initial start-up of the Smart Wiring Centre controls is carried out together with the initial start-up of the boiler.



If a Smart Wiring Centre is replaced by a Smart Wiring Centre 2 it has to be set on monozone mode.

#### Settings

- Flexicom  
Press “MODE” and “+” buttons simultaneously for 5 seconds. The display shows “0”.
- Ultracom  
Press “MODE” for 5 seconds. The display shows “0”.
- Use the “+” or “-” buttons (Ultracom use the heating control “+” or “-” button) to scroll through to number 35.
- Press “MODE”.
- Use the “+” or “-” buttons to scroll through to diagnostic number d.70.
- Press “MODE”.
- Change the setting using the “+” and “-” buttons. Refer to the table, for the most appropriate setting for the specific application.
- Save the new value by pressing “MODE”.
- To leave the diagnostic menu press and hold “MODE” until the running screen is displayed again.

### 3.2.2 Priorities are defined as follows:

Display	Meaning
0	<b>Hot water priority</b> - The 3-port valve is in the heating or hot water position depending on the operating mode. - With 2-port valves, either the DHW valve or the CH valve is open, both valves are closed on standby.
1	<b>Enable mid position</b> - The 3-port valve is in the mid position for simultaneous heating and hot water request, or in the heating or hot water position, depending on the operating mode. - With 2-port valves, both valves are open during simultaneous heating and hot water request. Otherwise, only one valve is always open and both valves are closed on standby.
2	<b>Only heating mode (only for test operation!)</b> - Only the CH valve is activated.

NOTE: Factory settings of boiler = 0 : hot water priority.



3.2.4 Monozone mode : Open vent or system boiler with DHW cylinder : two 2-Port Valves

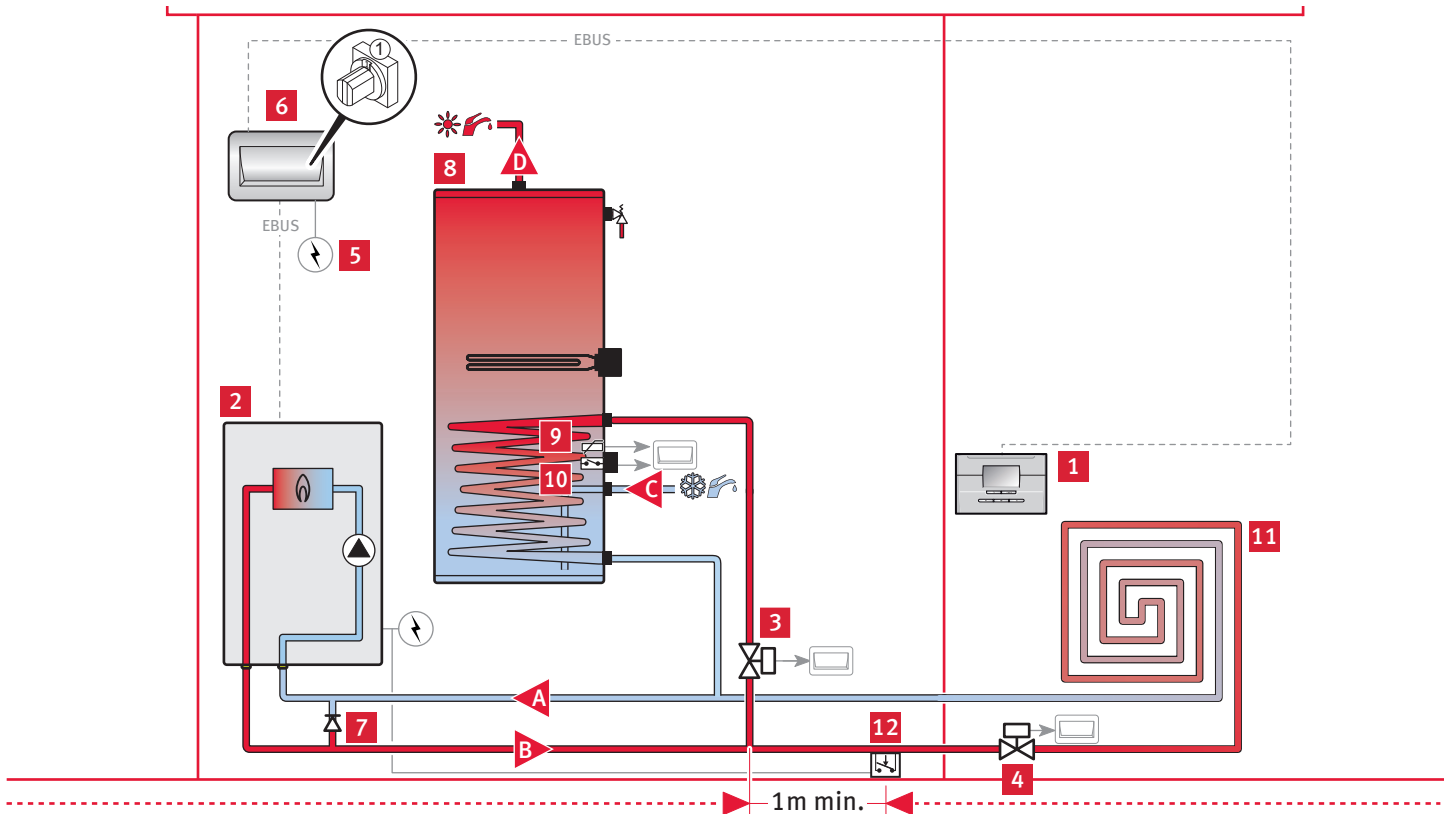

DHW cylinder with NTC

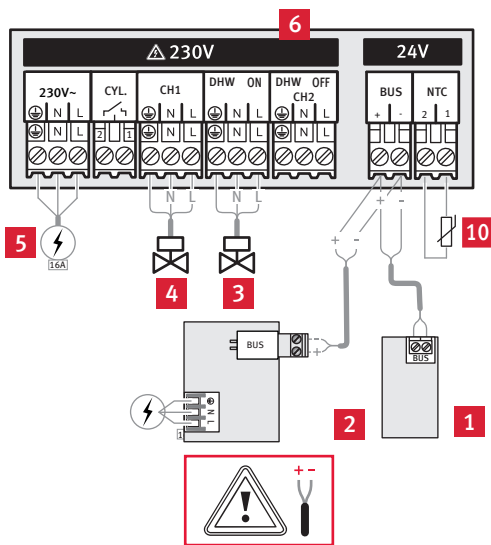

DHW cylinder with thermostat

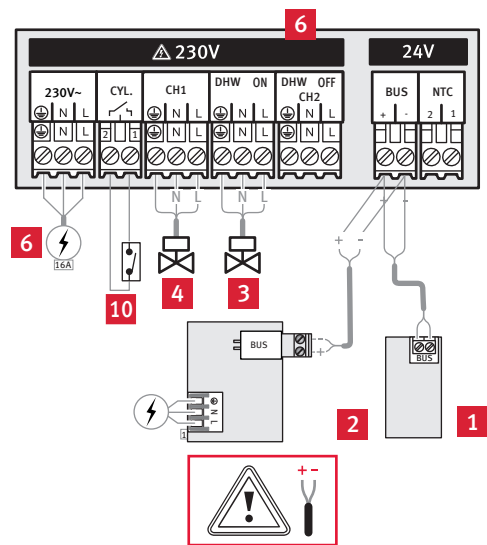

Key

- 1 Climapro room thermostat
- 2 System boiler
- 3 DHW valve - 2-port valve
- 4 Heating 2-port valve
- 5 Electrical supply
- 6 Smart Wiring Center 2 control unit
- 7 Bypass necessary with open vent boilers
- 8 Domestic hot water cylinder
- 9 NTC (not supplied)
- 10 Cylinder thermostat
- 11 Heating circuit
- 12 Overheating safety (if underfloor heating)

- A Boiler circuit return
- B Boiler circuit flow
- C Cold water supply
- D Domestic hot water outlet

## 3.2.5 Multizone operation mode

The Multizone operation mode is compatible with:

- Climapro<sub>1</sub>
- system, combi and open vent boiler

The information about the heating or hot water demand is sent to the room thermostat via the control unit to the boiler. The Smart Wiring Centre 2 then decides if the hot water demand needs to be fulfilled and drives the valves.

In this way, the boiler can store different target temperatures for heating and hot water modes.



The multizone mode is compatible with Flexicom and Ultracom ranges.

The multizone mode is only compatible with Climapro<sub>1</sub>. No other room thermostats are compatible.

The multizone mode will NOT support weather compensation and cannot be used on Y plan systems with three port motorised valves.

The standard installation for multizone mode is characterised by:

- 1 or 2 port valves for zoning,
- 1 or 2 Climapro<sub>1</sub> programmable wired room thermostats,
- heating zones and DHW cylinder cannot operate in parallel.

Priorities are defined as follows:

Priority levels	Function
1	Domestic hot water
2	Central heating

3.2.6 Multizone mode : Open vent or system boiler with DHW cylinder

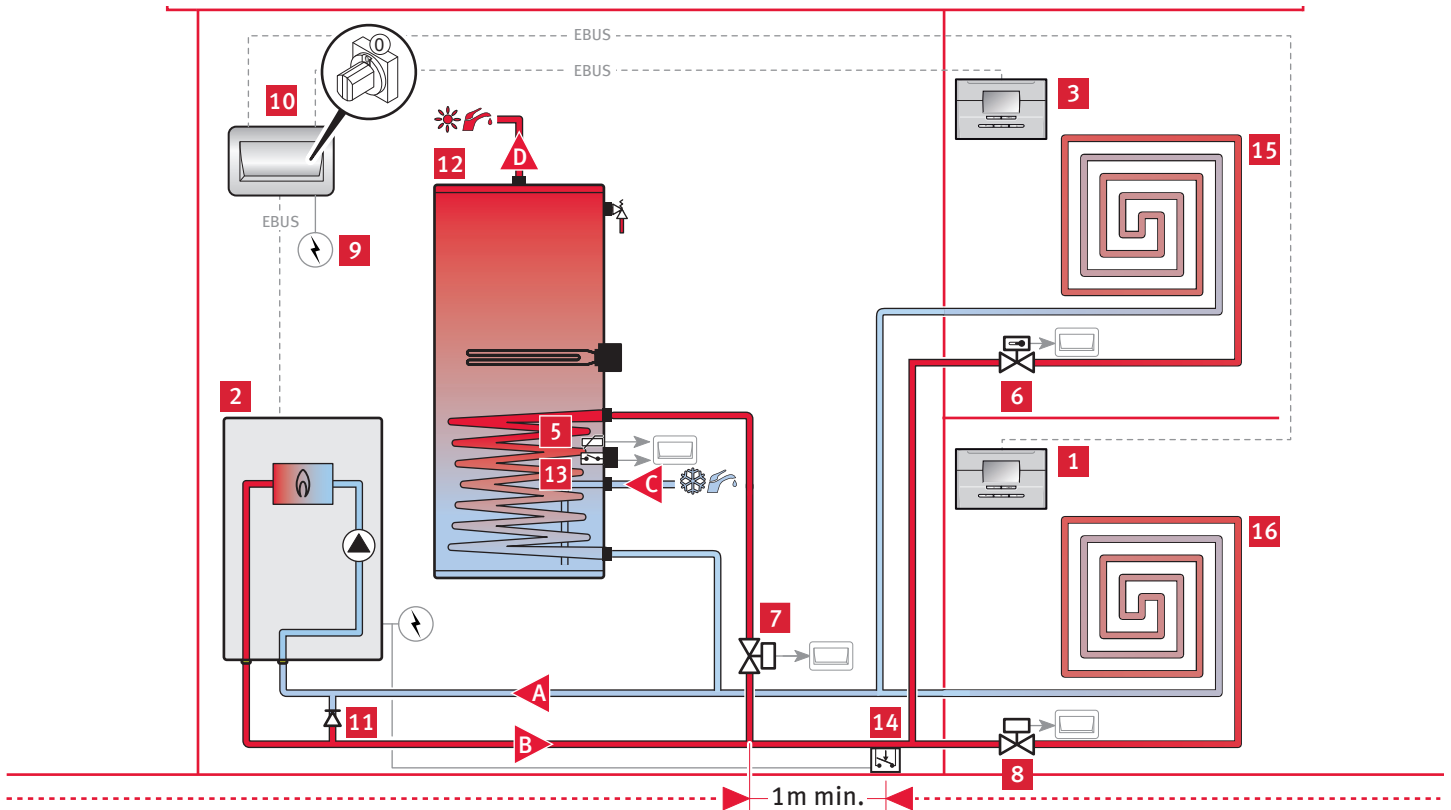

DHW cylinder with NTC

DHW cylinder with thermostat

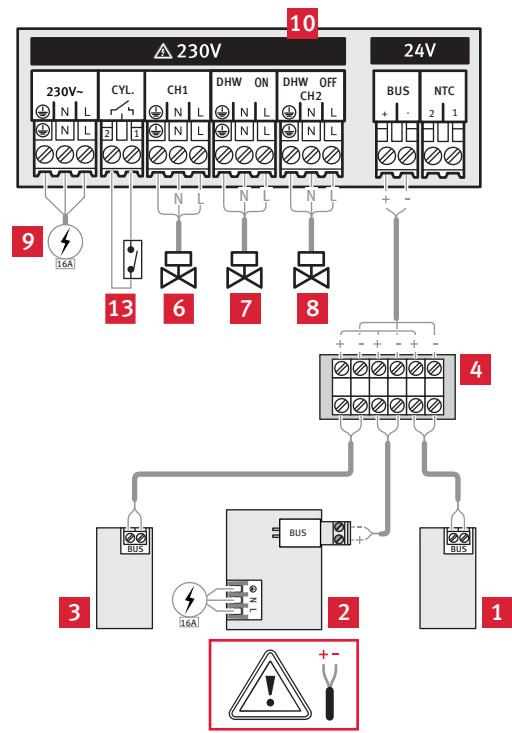
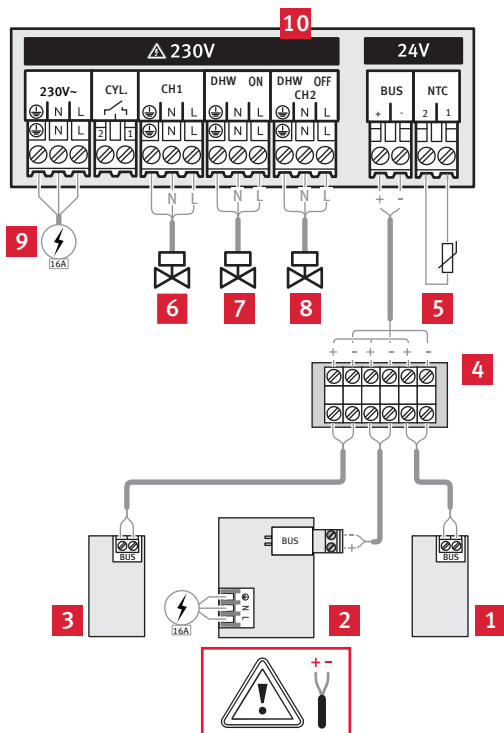

Key

- 1 Climapro<sub>1</sub> room thermostat "zone 1"
- 2 Open vent or system boiler
- 3 Climapro<sub>1</sub> room thermostat "zone 2"
- 4 Connection block (not supplied)
- 5 NTC (not supplied)
- 6 Heating zone 2 - 2-port valve
- 7 DHW valve - 2-port valve
- 8 Heating zone 1 - 2-port valve
- 9 Electrical supply
- 10 Smart Wiring Center 2 control unit
- 11 Bypass necessary with open vent boilers

- 12 Domestic hot water cylinder
- 13 Cylinder thermostat
- 14 Overheating safety (if underfloor heating), as far as possible or 1m min. of cylinder connection
- 15 Heating circuit zone 1
- 16 Heating circuit zone 2
- A Boiler circuit return
- B Boiler circuit flow
- C Cold water supply
- D Domestic hot water outlet

3.2.7 Multizone mode with combi boiler

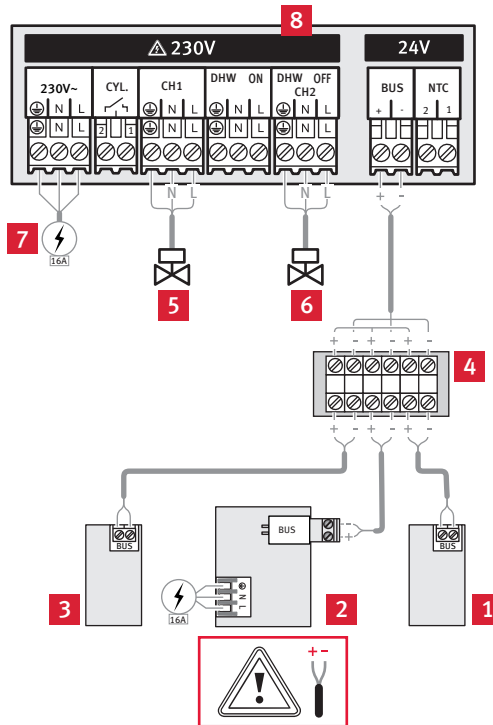
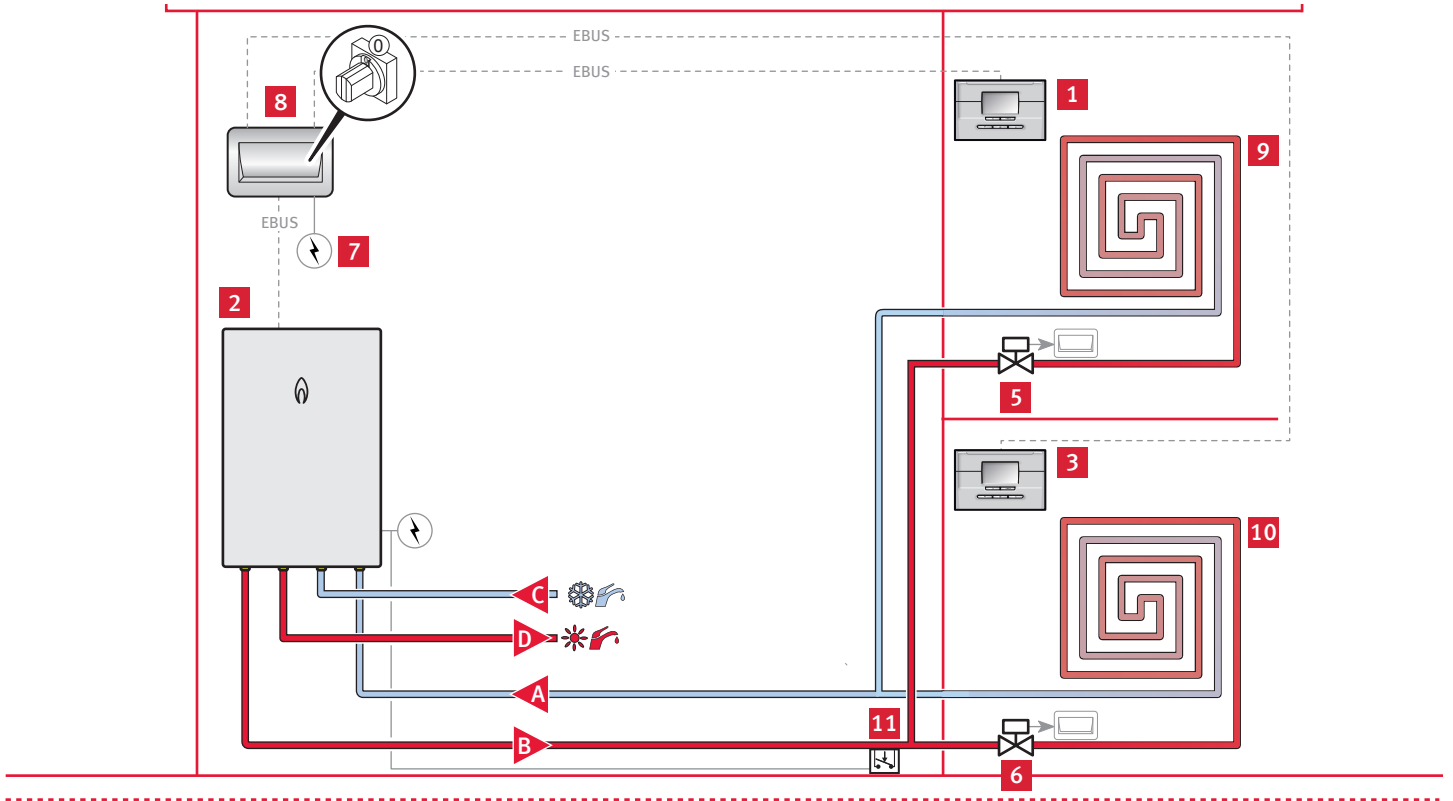

- Key
- 1 Climapro<sub>1</sub> thermostat "zone 2"
  - 2 Combi boiler
  - 3 Climapro<sub>1</sub> thermostat "zone 1"
  - 4 Connection block (not supplied)
  - 5 Heating zone 2- 2-port valve
  - 6 Heating zone 1- 2-port valve
  - 7 Electrical supply
  - 8 Smart Wiring Center 2 control unit
  - 9 Heating circuit zone 1
  - 10 Heating circuit zone 2
  - 11 Overheating safety (if underfloor heating)
- A Boiler circuit return
  - B Boiler circuit flow
  - C Cold water supply
  - D Domestic hot water outlet

EN

### 3.3 Type designation and serial number

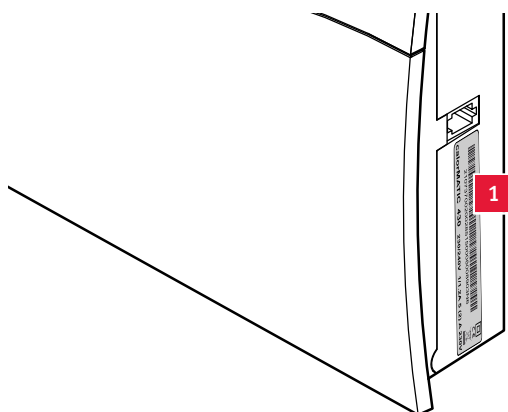

Data plate location:



### 3.4 Data plate description

The data plate certifies the country where the product is intended to be installed.

The data plate contains the following data:

Abbreviation/symbol	Description
Brand and Product name	GW Smart Wiring Center 2
Model	Product article number
V/Hz	Voltage / Frequency
T	Temperature range
Serial-no	Product serial number
	See chapter Recycling
	See chapter "CE label"
VA	Power Consumption

## 4 Mounting and installation

 All the dimensions shown of the illustrations are expressed in millimetres (mm).

### 4.1 Preparing the mounting and installation

#### 4.1.1 Considering the product location

Before choosing a site for the appliance, carefully read the safety warnings and instructions in the user guide and installation manual.

- Explain these requirements to the appliance user.
- Take all necessary precautions.

Install the system:

- in a room protected from frost,
- in a convenient location, accessible for wiring and servicing.

Do not install the control unit:

- close to heat sources such as radiators, chimney walls, televisions, direct sunlight,
- above a cooking device capable of generating steam and grease,
- in a room with a lot of dust or with a corrosive atmosphere.



**Caution!**

These pipes can become very hot which will damage the cables or the system.

- The electrical cables must not be attached to or in contact with the hydraulic pipes.

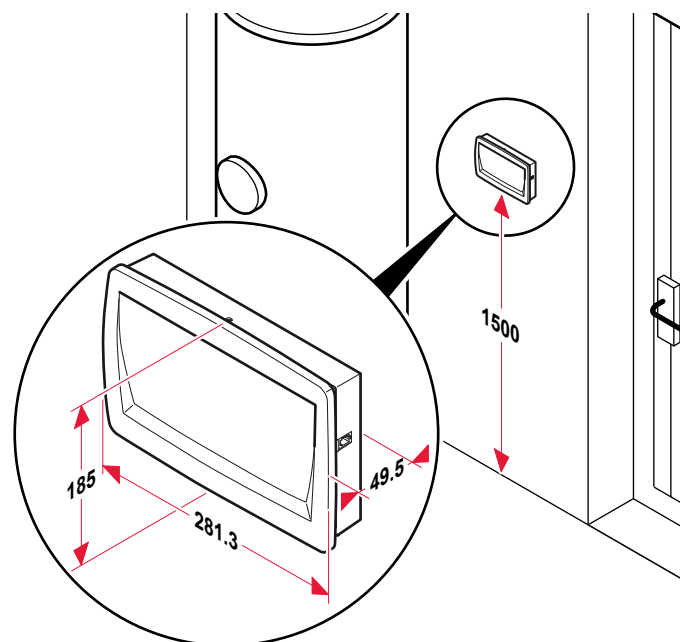

### 4.2 Mounting the product

#### 4.2.1 Opening the Smart Wiring Center 2

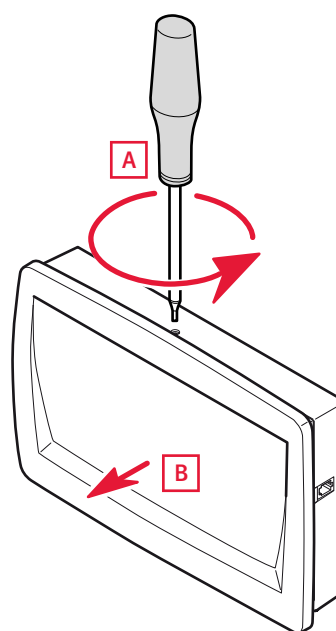

- Unscrew (A) the screw securing the housing cover.
- Pull (B) the housing cover forwards.

## 4.2.2 Wall-mounting of the product

The control unit is designed to be attached to a wall near the main tank inside a dwelling.

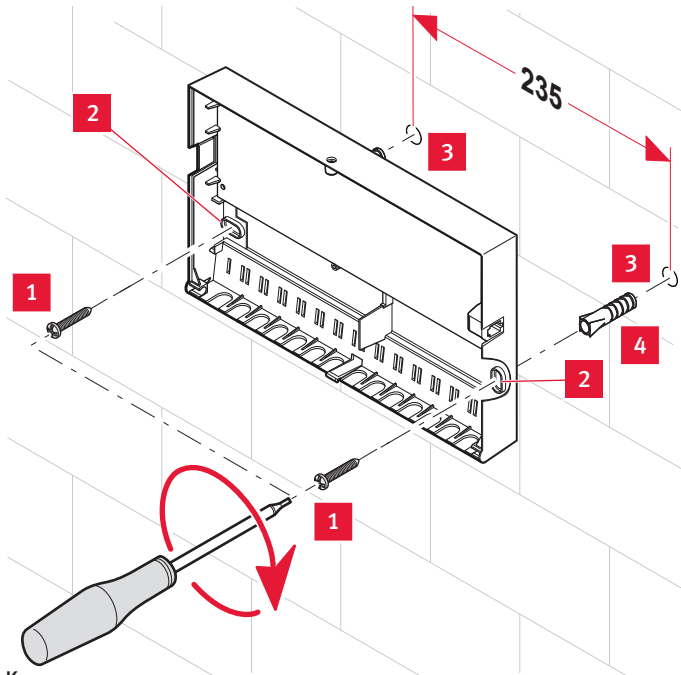

- Key
- 1 Screws
  - 2 Attachment holes
  - 3 Holes
  - 4 Plugs

- Determine the position depending on the requirements of the preceding chapter: "Appliance location".

## 4.3 Electrical Installation



**Danger!**  
Incorrect installation can cause electric shock or appliance damage.  
The electrical connection of the appliance must be made only by a qualified engineer.

- Ensure system is electrically isolated.  
Protect the electrical installation by following the guidance indicated in the "Technical data" chapter.



**Danger!**

- The length of the power supply cable must not exceed 10 metres.

- The electrical installation in the dwelling must permit the power supply to the equipment to be isolated by a double pole isolation switch and be fused. The double pole isolation switch must incorporate a gap of 3mm between the contacts.
- Use a power cable suitable for the main connection, minimum 1.5 mm. If the cable is damaged, it must be replaced by a qualified engineer.

The external wiring must be earthed, with correct polarity and in accordance with current standards.

The manufacturer declines any responsibility for damages to persons or others caused by the incorrect installation of the

appliance earthing. This includes failure to comply with current standards.



**Caution!**  
These pipes can become very hot which will damage the cables or the system.

- The electrical cables must not be attached to or in contact with the hydraulic pipes.

## 4.3.1 Description of connections

All of the internal connections are made directly to the circuit board.

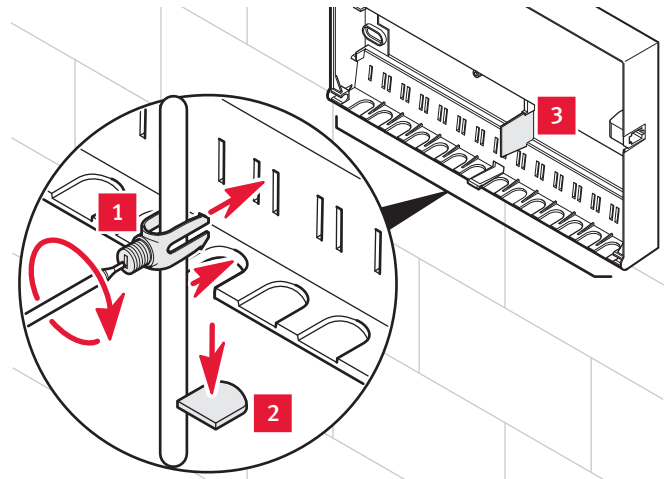

- Key
- 1 Cable clamp
  - 2 Divisible wire grommet
  - 3 Separating high and low voltage

The circuit board connectors are divided into two parts. The left part accepts a 230V power supply whereas the right part is used for 24V power.

### 230V connectors (High voltage)

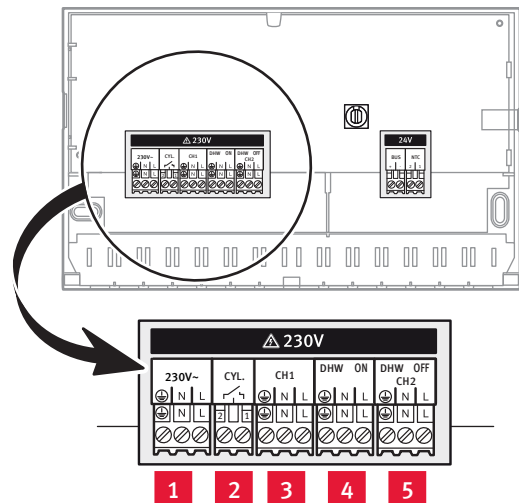

- Key
- 1 230V supply connector (3 pins: earth / neutral / live)
  - 2 Cylinder thermostat connector (2 pins)
  - 3 Heating zone 1 valve (3 pins: earth/neutral/ live)
  - 4 DHW valve ON (3 pins: earth / neutral / live)
  - 5 DHW valve OFF - Heating zone 2 valve (3 pins: earth/neutral/ live)

24V connectors (low voltage)

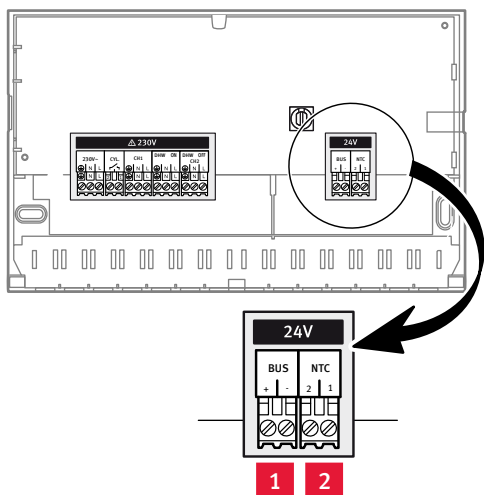

- Key  
 1 eBUS connector (2 pins)  
 2 NTC connector (2 pins)

4.3.2 Main board

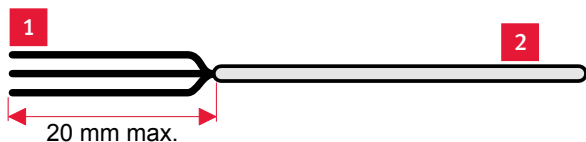

- Key  
 1 Electrical wires  
 2 Casing

When you connect the electrical wires to a connector on the main electronic board:

- Keep a distance of a maximum of 20 mm between connector and the start of the insulation (2).
- If single core wires are used (1) ensure that they are wrapped together in an insulating sheath.
- Fix the cables in the cable-clamps on the unit.

4.3.3 Glow-worm appliances with electrical cartridge housing

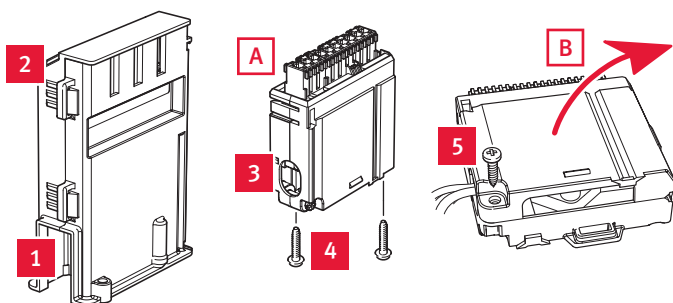

- Key  
 1 Access from underneath (remove rubber)  
 2 Cartridge housing  
 3 Tab  
 4 Retaining screws  
 5 Securing screw

Glow-worm open vent boilers Ultracom hxi Flexicom hx

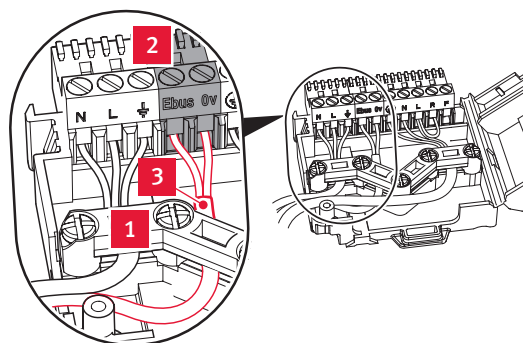

- Key  
 1 Cable strain relief  
 2 Connect to eBUS connection  
 3 Cable to smart wiring center 2 kit



The link wire will be necessary. You have to add the link between L & R (a link wire is not supplied).

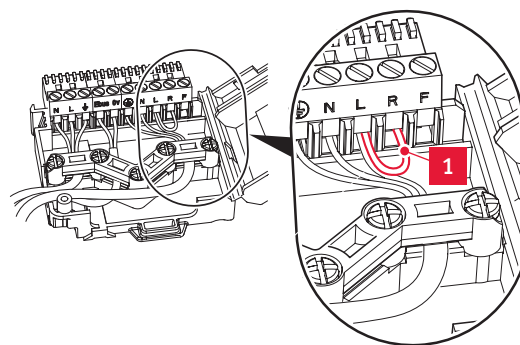

- Key  
 1 link wire

Glow-worm system boilers Ultracom sxi, Flexicom sx

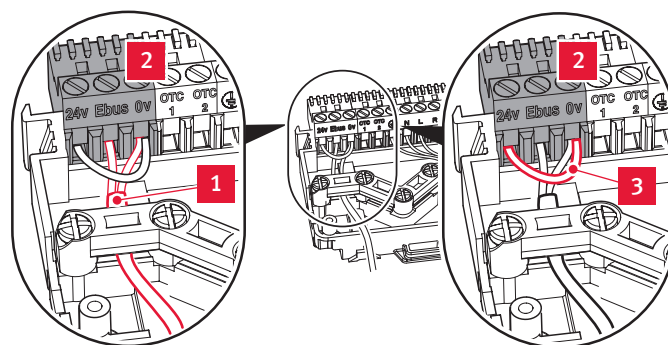

- Key  
 1 Cable to smart wiring center 2 kit  
 2 Connect to eBUS connection  
 3 link wire



The link wire will be necessary. You have to add the link between 0V & 24V (a link wire is not supplied).

4.3.4 GW appliances without electrical cartridge housing

The link wire is provided with boiler and already fitted to the 24V terminals (RT/24V). Link wire must not be removed if using with SWC2.

## 5 Commissioning

The commissioning should be carried out by a competent person approved at the time by the Health and Safety Executive and in accordance with the current issue of BS6798.

- Completely open all the radiator thermostatic valves in the rooms where the room thermostats were been installed.

### 5.1 Filling

#### 5.1.1 Boiler

Commission the boiler according to the instructions of its installation manual.

- Refer to the installer manual.

#### 5.1.2 Heating circuit

- Manually open the different heating circuit valves.

### 5.2 Venting

#### 5.2.1 Boiler

Commission the boiler according to the instructions of its installation manual.

- Refer to the installer manual.

#### 5.2.2 Heating circuit adjustment

Venting of the heating circuit enables the purging of any air in the heating circuit (valves still manually opened).

- Open the different heating circuit air vent.



**Caution!**

- When venting is complete, close the different heating circuit air vent and valves.

### 5.3 Switching on

- Turn on all the appliances that make up the installation (see the installation manual(s)). Use the following order:

- Control unit
- Boiler

### 5.4 Multizone specific adjustment

In case of multizone mode selection (rotary switch in pos 0), the pairing must be made between the room thermostat(s) and control unit in the system heating (one after the other).

- Follow the install assistant of the room thermostat "zone 1".
- Consult the installation manual of the room thermostat in order to carry out the operation.
- Repeat the operation with the room thermostat "zone 2"

### 5.5 Restart and check

- Check if all settings have been saved by switching the system off and then on to ensure that any adjustments operate correctly and check that the appliances operate safely.
- Check if the system answers correctly to a demand:
  - issue a heating demand for the heating zone 1
  - issue a heating demand for the heating zone 2 (If multizone mode is selected)
  - issue a domestic hot water demand (if DWH tank is connected)

## 6 User information

At the end of the installation, the installer must:

- explain the operation of the appliance and its safety devices to the user, if necessary provide a demonstration and answer any questions;
- give the user all the required documentation,
- fill in the documents where necessary;
- advise the user of the precautions necessary to prevent damage to the system, appliance and the building;
- remind the user to service the appliance annually.

## 7 Maintenance

### 7.1 Trouble-shooting

#### 7.1.1 Fault diagnosis

The following checks should be performed before proceeding onto specific diagnostics:

- Ensure that the control unit has not been disconnected from the electricity supply and that it is connected correctly.
- Ensure that all installation's appliances are available.
- Check the functioning of external regulatory devices (room thermostat(s)).



The rectification of faults described in this chapter should be carried out by a qualified engineer and if needed by the After Sales Service.

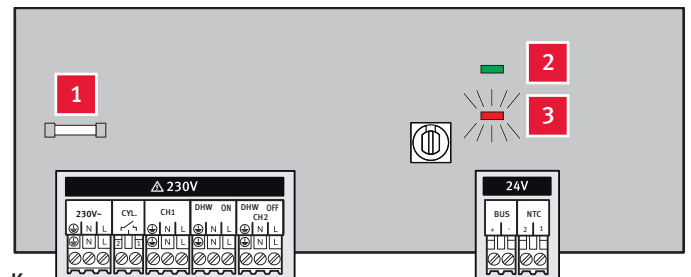

- Key
- 1 Fuse
  - 2 Green LED, power supply
  - 3 Red LED flashes, fault

Fault	Possible cause	Solution
Green LED permanently off	No 230 V power supply or the fuse in the appliance is faulty	Check that the main voltage cable is connected correctly. Check the domestic fuse for the 230 V supply and re-connect the power supply. Replace the main supply fuse in the control unit (see technical data).
Red LED flashes quickly (2 Hz, 2 flashes/second)	Short circuit of the connected temperature sensor (NTC) in the cylinder	Check the cable of the temperature sensor (NTC) for damage. Replace the temperature sensor (NTC) in the cylinder.
Red LED flashes slowly (0,5 Hz, 1 flashes/ 2 seconds)	Communications error with the eBUS boiler.	Check that the boiler's eBUS cable is connected correctly and not damaged. Check that the boiler is turned on.
Heating zone valves not operating	Valve disconnected. Valve doesn't open.	Check the room thermostat(s) compatibility and connections. Check the valve connections. Check the room thermostat(s) pairing. Ensure that there is no interruption to the electricity supply and that the unit control is properly connected and turned on.
DHW valve not operating		
Fault domestic hot water cylinder	Cylinder dual thermostat disconnected. The temperature sensor is defective or disconnected.	Check the cylinder dual thermostat and temperature connections. Check the sensor's resistance. Ensure that there is no interruption to the electricity supply and that the control unit is properly connected and turned on.

## 7.2 Main supply cable



### Danger!

- The main supply cable must be replaced by a qualified and competent electrician.

- If the main supply cable is damaged, replace it referring to the chapter "Electrical connection".

## 8 Decommissioning

- Switch off the product.
- Isolate the product from the power mains.
- De-install the product.
- Recycle or dispose the product and its components (see chapter 9).

## 9 Recycling and disposal

### 9.1 Recycle the packaging

- Sort the waste to separate those which can be recycled (cartons, plastics...) from those that cannot (strapping ...).
- Recycle the product packaging according to all relevant regulations.

### 9.2 WEEE: Recycle or dispose the product and its components

The product must be recycled under the WEEE Directive (Waste Electrical and Electronic Equipment), which specifies:

- the selective collection of waste electrical and electronic equipment.
- the selective systematic treatment of certain components and substances considered as dangerous,
- the reuse, recycling and recovery of the collected WEEE.



- Do not dispose of your product or any of its accessories in the household waste.
- Make sure the old unit and any accessories are disposed of properly.

- Deposit the product at an appropriate collection point for the treatment, evaluation and recycling of WEEE.
- Observe all relevant regulations.



By adhering to this directive, you are helping the environment and contributing to the preservation of natural resources and the protection of human health.

## 10 Guarantee and customer service

We only grant a manufacturer's guarantee if a suitably qualified engineer has installed the system in accordance with the instructions. The system owner will be granted a guarantee in accordance with the manufacturer's terms and conditions. For all requests for work during the guarantee period contact your after sales organisation on 01773 828100.

## 11 Technical data

Description	Unit	Smart Wiring Center 2
Power-supply voltage	V/Hz	230/50
Power consumption	VA	4
Contact load of output relays (max.)	A	2
Delay fuse	A	T 4A/250V
Contact voltage for DHW cylinder thermostat	V	230
Temperature sensor (NTC) operating voltage	V	5
Thermistor NTC at 25°C	kOhm	2,7
eBUS connection cable gauges	mm <sup>2</sup>	2 x 0.75
Maximum length of eBUS cable	m	300
Power cable gauge	mm <sup>2</sup>	3 x 1.5
Maximum length of power cable	m	10
Dimensions :		
Height	mm	185
Length	mm	281.3
Depth	mm	49.5
Electrical protection		IP20
Electrical classification		II





Subject to engineering changes

0020140826\_00 - 08/12

## GLOW-WORM

Nottingham Road,  
Belper, Derbyshire.  
DE56 1JT

[www.glow-worm.co.uk](http://www.glow-worm.co.uk)

Because of our constant endeavour for improvement, details may vary slightly from those shown in these instructions.

**Glow•worm**  
The energy you need