

# Grant Vortex

Boilerhouse

Condensing Oil Boiler Range

User Instructions

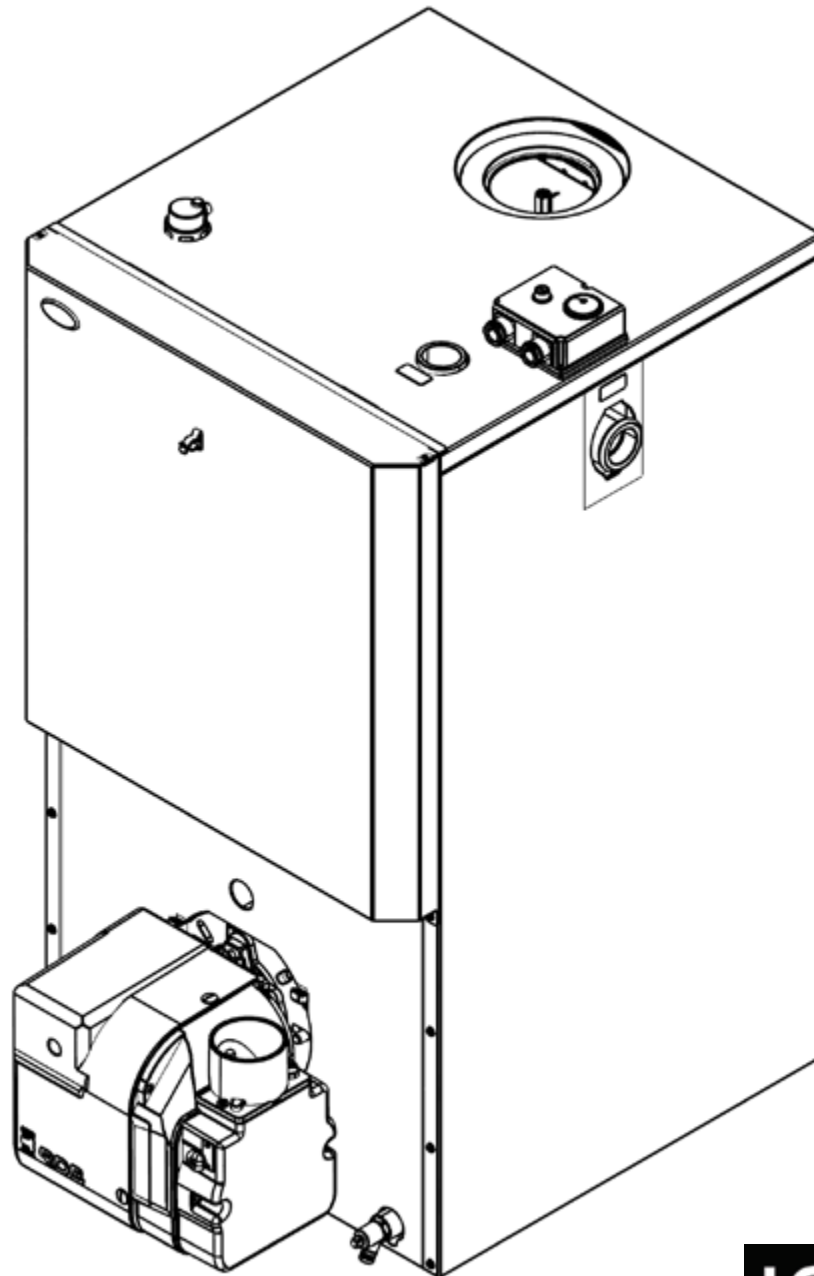

**LOW NO<sub>x</sub>**  
**READY**

## IMPORTANT NOTE FOR USERS

These user instructions are intended to guide the user in the operation of the Grant Vortex oil boiler.

A separate manual is available to guide installers on the installation, commissioning and servicing of the Grant Vortex oil boiler.

## SPECIAL TEXT FORMATS

The following special text formats are used in these instructions for the purposes listed below:

### **! WARNING !**

Warning of possible human injury as a consequence of not following the instructions in the warning.

### **! CAUTION !**

Caution concerning likely damage to equipment or tools as a consequence of not following the instructions in the caution.

### **! NOTE !**

Used for emphasis or information not directly concerned with the surrounding text but of importance to the reader.

## PRODUCT CODES COVERED

These instructions cover the following product codes:

Product code	Product description
VTXBH1521	Vortex Boilerhouse 15/21 oil boiler
VTXBH2126	Vortex Boilerhouse 21/26 oil boiler
VTXBH2635	Vortex Boilerhouse 26/35 oil boiler
VTXBH3646	Vortex Boilerhouse 36/46 oil boiler
VTXBH4658	Vortex Boilerhouse 46/58 oil boiler
VTXBH5870	Vortex Boilerhouse 58/70 oil boiler

## SERVICING

The boiler should be serviced at least every twelve months and the details entered in the Service Log in this user handbook.

## FUEL TYPE

All Grant Vortex boilers are suitable for use with Class C2 Kerosene.

The use of Class D Gas Oil on all Grant Vortex Low NOx and Blue Flame boilers DOES NOT comply with ErP requirements or EU regulations, and as a result Grant UK does not condone its use.

If your boiler uses Bio-Kerosene (B30K), refer to the installation and servicing instructions.

### **! NOTE !**

**This appliance can be used by children aged from 8 years and above and persons with reduced physical, sensory or mental capabilities or lack of experience and knowledge if they have been given supervision or instruction concerning use of the appliance in a safe way and understand the hazards involved.**

**Children shall not play with the appliance. Cleaning and user maintenance shall not be made by children without supervision.**



## GRANT ENGINEERING (UK) LIMITED

Hopton House, Hopton Industrial Estate, Devizes, Wiltshire, SN10 2EU

Tel: +44 (0)1380 736920 Fax: +44 (0)1380 736991

Email: [info@grantuk.com](mailto:info@grantuk.com) [www.grantuk.com](http://www.grantuk.com)

This manual is accurate at the date of printing but will be superseded and should be disregarded if specifications and/or appearances are changed in the interests of continued product improvement. However, no responsibility of any kind for any injury, death, loss, damage or delay however caused resulting from the use of this manual can be accepted by Grant Engineering (UK) Limited, the author or others involved in its publication.

All goods sold are subject to our official Conditions of Sale, a copy of which may be obtained on application.

© Grant Engineering (UK) Limited. No part of this manual may be reproduced by any means without prior written consent.

# CONTENTS

<b>1</b>	<b>INTRODUCTION</b>	<b>4</b>
1.1	About your boiler	4
1.2	Boiler controls access	4
1.3	What the installer should leave you with	4
1.4	Commissioning	4
1.5	Activating the guarantee	4
1.6	Boiler servicing	4
1.7	Boiler data plate	4
<b>2</b>	<b>USING YOUR BOILER</b>	<b>5</b>
2.1	Lighting your boiler	5
2.2	If your boiler fails to light	5
2.3	Turning off your boiler	5
2.4	About your fuel	5
2.5	Boiler controls	5
2.6	Heating system controls	6
2.7	Electricity supply	6
<b>3</b>	<b>CARING FOR YOUR BOILER</b>	<b>6</b>
3.1	Checking sealed system pressure	6
3.2	How to fill or top up your sealed system	7
3.3	Expansion vessel	7
3.4	Ventilation	7
3.5	Flue terminal and condensate disposal	7
3.6	Frost protection	8
3.7	Failure of electricity supply	8
3.8	Cleaning your boiler	8
<b>4</b>	<b>AFTER SALES SUPPORT</b>	<b>8</b>
<b>5</b>	<b>SERVICE LOG</b>	<b>9</b>
	<b>NOTES</b>	<b>11</b>

# 1 INTRODUCTION

## 1.1 ABOUT YOUR BOILER

The boiler is fully automatic once switched on, providing central heating (and also domestic hot water if you have a hot water cylinder fitted).

The temperature of the water leaving your boiler to heat your property is controlled by the boiler thermostat (see Figure 2-1), which is located on the boiler dual thermostat (see Figure 1-1).

If your boiler is connected to a programmer, it will provide hot water and central heating during the time periods set on the programmer.

## 1.2 BOILER CONTROLS ACCESS

The boiler is controlled by a dual thermostat, which is located on the top of the boiler, on the right hand side.

It will either be mounted on a bracket and facing forwards (15/21, 21/26, 26/35 and 34/46 models), or will be mounted flat on the top panel of the boiler (46/58 and 58/70 models).

Refer to Figure 1-1 for the dual thermostat's location on the Grant Vortex Boilerhouse boilers.

## 1.3 WHAT THE INSTALLER SHOULD LEAVE YOU WITH

- A completed OFTEC CD10 (installation completion report)
- A completed OFTEC CD11 (servicing and commissioning report)
- The boiler installation and servicing instructions
- This user handbook

The installer should have advised you how to operate the boiler and controls, and whether the boiler operates as part of a sealed system or an open vented system.

If the boiler operates as part of a sealed system, the installer should have shown you how to check and top up the heating system should your system pressure drop. Also see Sections 3.1 and 3.2.

## 1.4 COMMISSIONING

Following installation, your boiler should be commissioned by a competent person, such as an OFTEC registered engineer, to validate the guarantee.

During the commissioning process, your boiler will be set to its optimum efficiency using specialist flue gas analysis equipment.

Your installer should arrange for this to be carried out.

If required, Grant UK can provide details of OFTEC registered commissioning engineers in your area.

## 1.5 ACTIVATING THE GUARANTEE

In order for your boiler's full\* guarantee to be activated, your boiler must be registered with Grant UK within 30 days of its installation\*\*.

To register your boiler, please either call Grant UK on: 01380 736920 or visit the Grant UK website: [www.grantuk.com](http://www.grantuk.com).

Your installer may have registered the boiler on your behalf and provided you with the relevant documentation.

\*If registered within 30 days of installation, your boiler will come with a 2 year guarantee. Extended guarantees are also available upon request; please contact Grant UK for further details.

\*\*If the boiler is not registered within 30 days of installation, your boiler will come with a 12 month guarantee.

Please refer to the boiler installation and servicing instructions for the full terms of the manufacturer's guarantee.

## 1.6 BOILER SERVICING

Your boiler must be serviced every 12 months from the date of installation to maintain the guarantee, for the entire duration of the guarantee (this includes any extended guarantee that may have been purchased).

The nozzle and braided oil hose should be replaced annually (unless a 'long life' oil hose is fitted, in which case refer to the manufacturer's instructions for details on service life). If the boiler is part of a sealed system, the air pressure charge of any expansion vessels fitted to the system must be checked annually.

Please make sure that your installer has recorded the service information in the Service Log at the back of these user instructions. Should you ever need to utilise the product guarantee, you will be asked to provide the service history of the boiler.

## 1.7 BOILER DATA PLATE

Your boiler is fitted with a data plate, which shows any engineers who come to service or repair your boiler some basic information they may need to know in order to carry out their required works.

The data plate also contains the boiler serial number, which is required by Grant UK when registering the boiler.

This data plate can be found on the top boiler casing panel.

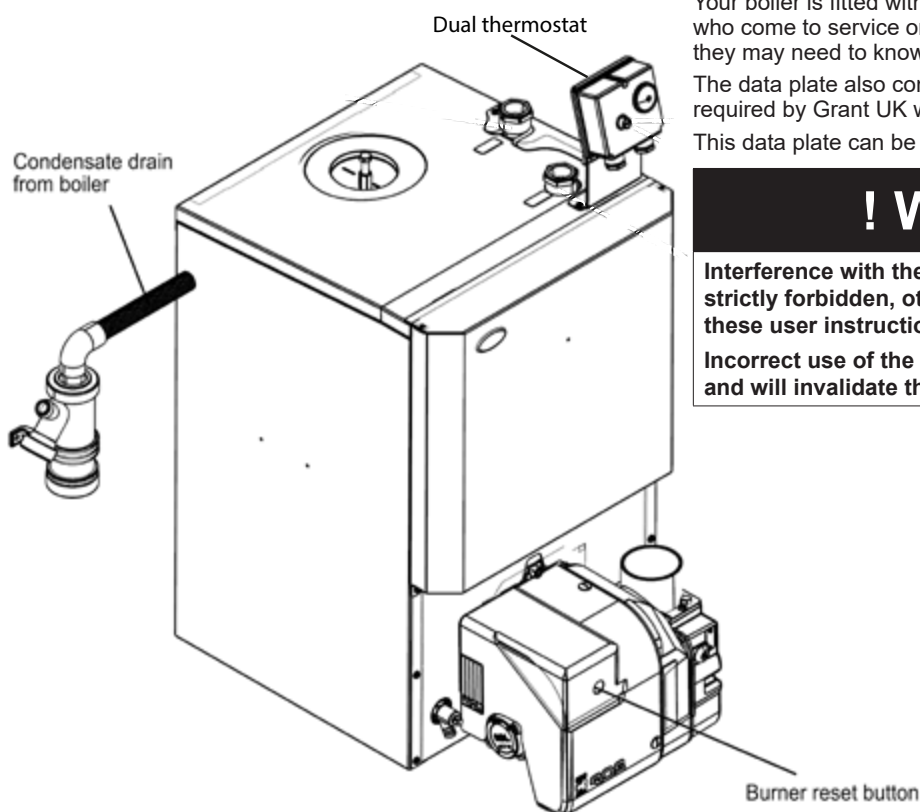

Figure 1-1: Boiler components (model shown: 26/35kW)

## ! WARNING !

**Interference with the boiler (or any sealed component) is strictly forbidden, other than where information is given in these user instructions.**

**Incorrect use of the boiler can result in danger to the user and will invalidate the guarantee.**

## 2 USING YOUR BOILER

### 2.1 LIGHTING YOUR BOILER

The lighting procedure is:

1. Ensure that:
  - a) There is sufficient fuel, of the correct type, in the supply tank and that all fuel supply valves are open.
  - b) The water supply is on.
  - c) The electricity supply to the boiler is OFF.
  - d) The room thermostat (if fitted) is at the desired setting.
  - e) The boiler thermostat is set to the required setting.
2. Switch the electricity supply to the boiler ON.
3. If fitted, set the programmer to ON (either central heating (CH) or hot water (HW)).
4. The boiler will now light automatically.
5. If a programmer is fitted, refer to the instructions supplied with the programmer and set the CH and HW functions to TIMED.  
The boiler will now operate during the 'on' periods set on the programmer.

### 2.2 IF YOUR BOILER FAILS TO LIGHT

Make the following checks:

1. Check that the boiler thermostat is set to the required setting.
2. Check that the programmer (if fitted) is working and is set to ON (CH or HW).
3. Check that all thermostats are set to the desired setting and are calling for heat.
4. Check if the burner 'Lock-Out' reset button on the burner body (refer to Figure 1-1 for location) is lit.  
If it is, press it to start the burner.  
If the burner fails to light and goes to 'Lock-Out' again, check that you have sufficient fuel in the storage tank and that the fuel supply valve is open.
5. Check that the fire valve in the oil supply line has not tripped.
6. Ensure that a fuse has not blown or that the electricity supply has not failed.
7. Check to see if the overheat thermostat has operated (see Section 2.5).

If the burner still fails to light after carrying out these checks then a fault exists or the fuel supply is low. If you have sufficient fuel, switch off the electricity supply to the boiler and contact your service engineer.

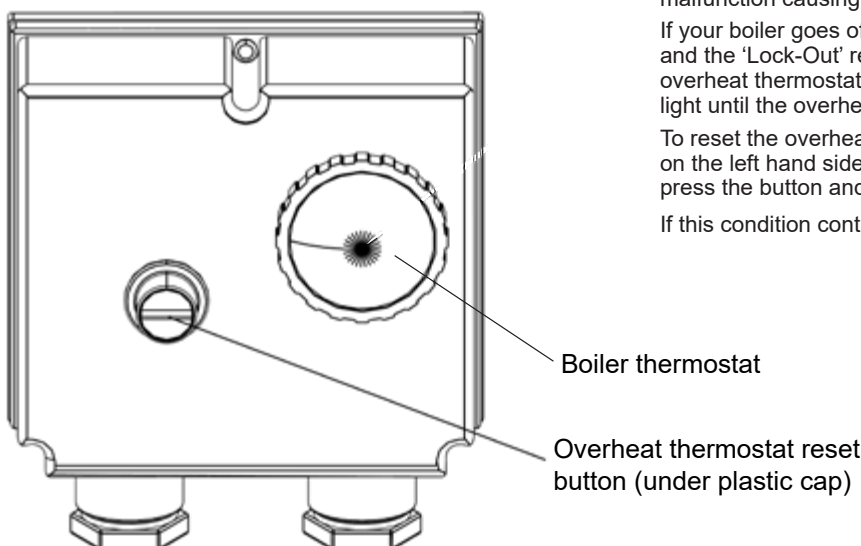

Figure 2-1: Dual thermostat

### 2.3 TURNING OFF YOUR BOILER

To turn off your boiler:

- **For short periods-**  
Turn the electricity supply to the boiler off.  
To restart, simply switch the supply back on.
- **For long periods-**  
Turn the electricity supply to the boiler off. If required, the fuel supply valve may be closed and the water and electricity supplies turned off at the mains.  
To restart, refer to Section 2.1 (Lighting your Boiler).

## ! NOTE !

**Your installer should have shown you where the isolation switch for the electricity supply to your boiler and the control system is located in your property.**

**If you cannot locate this isolator, contact your installer.**

### 2.4 ABOUT YOUR FUEL

Grant Vortex boilers only operate on Class C2 Kerosene to BS 2869:1998.

You should always quote this type of fuel when ordering from your supplier.

Do not wait until the fuel runs out before you order some more as sludge in the bottom of the tank may be drawn into the fuel lines. If it is possible, switch off the boiler when the new supply is delivered and leave the fuel to settle for an hour before restarting the boiler.

### 2.5 BOILER CONTROLS

#### BOILER THERMOSTAT

This dial, located on the boiler dual thermostat, allows the temperature of the water leaving the boiler to heat the radiators (and/or other heat emitters if fitted) and domestic hot water to be adjusted.

Refer to Figure 1-1 for the location of the dual thermostat on the boiler casing and Figure 2-1 for the details of the dual thermostat.

## ! NOTE !

**If you have a cylinder thermostat on your hot water cylinder, this will control the temperature of your domestic hot water.**

**The boiler thermostat setting must be equal to or greater than the cylinder thermostat setting to enable the cylinder thermostat to control the domestic hot water system.**

#### OVERHEAT THERMOSTAT

Your boiler is fitted with a safety overheat thermostat which will automatically switch off the boiler in the case of a control malfunction causing overheating.

If your boiler goes off and you try to light it but nothing happens and the 'Lock-Out' reset button on the burner is not lit, the overheat thermostat has probably operated. The boiler will not light until the overheat thermostat is reset.

To reset the overheat thermostat, unscrew the small plastic cap on the left hand side of the dual thermostat (see Figure 2-1), press the button and replace the cap.

If this condition continually repeats, contact your service engineer.

## 2.6 HEATING SYSTEM CONTROLS

### PROGRAMMER (IF FITTED)

If a programmer is fitted, it will control the times that the boiler heats the central heating system and hot water cylinder (if fitted). Refer to the manufacturer's instructions supplied with your programmer for further details.

### ROOM THERMOSTAT

This thermostat allows you to control the room temperature at which the boiler will fire to provide central heating to your property. The room thermostat is usually located in a downstairs area such as a hallway or living area.

If your heating system is 'zoned' you will have more than one room thermostat, with each thermostat controlling the temperature of a separate heating zone.

## ! NOTE !

**For your boiler to operate to provide you with heating, the programmer (or timer) must be in an 'ON' period for heating AND the room thermostat must be 'calling' for heat.**

### CYLINDER THERMOSTAT

This thermostat controls the temperature of the water in your hot water cylinder (if fitted), as long as your cylinder is being heated by the boiler.

When the water temperature in the cylinder is below the thermostat set temperature, it will 'call' for the boiler to operate to heat your hot water.

## ! NOTE !

**For your boiler to operate to provide heat to your hot water cylinder, the programmer (or timer) must be in an 'ON' period for hot water AND the cylinder thermostat must be 'calling' for heat.**

### THERMOSTATIC RADIATOR VALVES

Your heating system may also include Thermostatic Radiator Valves (or TRVs). If you have them, they will be fitted on some or all of your heating system radiators.

A TRV is a self-regulating valve, i.e. not connected to the other heating system controls, such as a programmer or room thermostat, and is designed to regulate the temperature in the room in which it is situated.

A TRV senses the air temperature around it and controls the water flow to the radiator on which it is fitted to regulate its heat output to the room. The head of the TRV can be rotated to set it to give the required room temperature. Once correctly set, it should ideally be left in that position and not used as an on/off control for the radiator.

As the correct operation of a TRV is based on it sensing the air temperature of the room it is fitted in, take care not to cover the TRV head (with curtains, furniture etc).

Refer to the manufacturer's instructions supplied with any TRVs fitted to your heating system for further details.

## 2.7 ELECTRICITY SUPPLY

The boiler requires a 230/240 V AC 50 Hz supply. It must be protected by a 5 Amp fuse.

## ! WARNING !

**The electrical connections to the boiler must be earthed.**

# 3 CARING FOR YOUR BOILER

## 3.1 CHECKING SEALED SYSTEM PRESSURE

If your boiler is operating on a sealed system, your installer will have pressurised the system and should have told you (or set it on the pressure gauge\*) the system pressure when cold. This pressure is normally between 0.5 and 1.0 bar, which will increase slightly when the system is hot.

\*Your installer should have shown you where the system pressure gauge is located.

You should frequently check that the system pressure is correct.

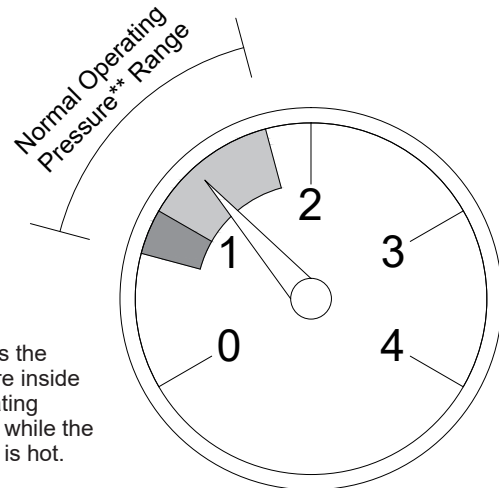

\*\*This is the pressure inside the heating system while the system is hot.

Figure 3-1: Pressure gauge during normal boiler operation

If the pressure (when the heating system is cold) is below the set pressure mentioned above, you can re-pressurise the system by following the instructions given in Section 3.2.

If the system requires re-pressurising frequently, ask your installer or service engineer to check the heating system for leaks and to check the expansion vessel air charge.

### AIR VENTS

The boiler and/or system will be fitted with an air vent to remove air from the system.

Any air trapped in the radiators should be removed by venting the radiators using the vent screw at the top of each radiator. Only vent a radiator if the top is cool and the bottom is hot. Excessive venting will reduce the system pressure, so only vent when necessary and check the system pressure as mentioned above.

Re-pressurise the system if necessary.

### PRESSURE RELIEF (SAFETY) VALVE

The sealed system will be fitted with a safety valve to release excess pressure from the system. If water or steam is emitted from the safety valve discharge pipe, switch off the boiler and contact your installer or service engineer immediately.

### 3.2 HOW TO FILL OR TOP UP YOUR SEALED SYSTEM

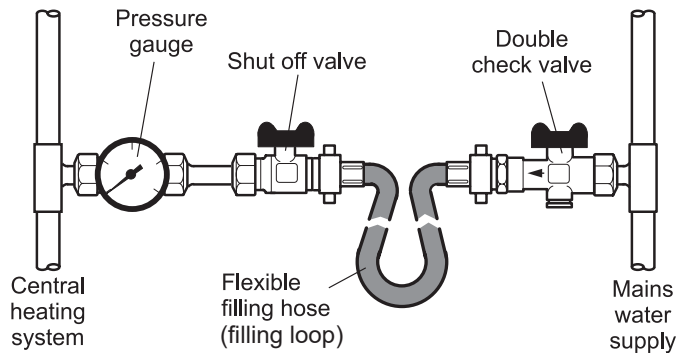

Figure 3-2: Sealed system filling loop arrangement

To fill or top up your heating system, proceed as follows:

1. Check the boiler and circulating pump are switched off and any air vents on the system are open.
2. Connect the filling loop\* between the two filling valves.
3. Open the filling valve on the mains water end of the filling loop (the valve is open when the operating lever is in line with the valve).
4. Open the filling valve on the heating end of the filling loop to allow water to flow into the heating system (the valve is open when the operating lever is in line with the valve).
5. When the pressure gauge shows the required cold system pressure (refer to Section 3.1) close the filling valve on the heating system.
6. Vent each radiator to remove any air that may be trapped in them. Start with the lowest radiator in the system, i.e downstairs.
7. Locate the circulating pump(s) and vent the pump(s) by following the manufacturer's instructions.
8. Now, check the system pressure on the system pressure gauge. If necessary, re-open the filling valve on the system until the gauge shows the required pressure. Take care not to over-fill!
9. Finally, close both filling valves and disconnect the filling loop at one end only. Take care, as the filling loop may contain water!

\*If you cannot locate the filling loop, please contact your installer.

## ! NOTE !

If the system has been drained down or requires frequent topping up, then the level of inhibitor and/or anti-freeze will need to be checked by your installer.

## ! WARNING !

Only add water to the system when the system is cold and the boiler is switched off.  
Do not overfill

### 3.3 EXPANSION VESSEL

The expansion vessel should be checked annually, as part of your annual service, to ensure that there is a 1.0 bar air charge in the vessel. Failure to do this will invalidate the boiler guarantee. Refer to Section 1.6 for further details regarding servicing.

## ! NOTE !

The pressure gauge on the system does not show the air charge pressure in the expansion vessel.

## ! NOTE !

In order to properly care for your Grant boiler, an annual service by a competent person should always be undertaken.

### 3.4 VENTILATION

Unless your boiler is installed with a balanced flue system\*, you will require ventilation openings in your property to provide your boiler with a fresh supply of air in order for it to fire.

Any ventilation openings in the property provided by the installer must not be obstructed.

You should periodically check that they are clear.

Do not attempt to 'box in' the boiler or build a compartment around it before contacting your installer.

Do not place any combustible material around or on the boiler or flue pipe.

\*Balanced flue systems have an air intake system incorporated into their design, and provide the boiler with fresh air. This removes the need to have ventilation openings installed in your property for this purpose.

### 3.5 FLUE TERMINAL AND CONDENSATE DISPOSAL

#### FLUE TERMINAL

If your boiler flue system has a terminal on the outside wall, make sure that the terminal is not damaged or obstructed in any way.

A wire mesh guard is required to cover the terminal if the terminal is less than 2 metres above ground level. If you think one is required, contact your installer.

You should periodically check for and remove any obstructions, e.g. cut back any bushes that may have grown over the terminal. Do not stack anything against or in front of the terminal.

In severe weather conditions, check that the terminal does not become blocked by snow or ice.

#### 'PLUMING' FROM THE FLUE TERMINAL

Whilst operating, it is quite normal for the boiler to produce a white plume of condensation vapour from the flue terminal.

This is due to the high efficiency of the boiler and may be particularly evident with low outdoor temperatures.

#### CONDENSATE DISPOSAL

During the operation of the boiler, condensate is produced from the flue gases and this is drained to a suitable disposal point through the plastic waste pipe on the left hand side of the boiler. (See Figure 1-1 for location).

The condensate drain must not be modified or blocked.

Blockage of the condensate drain, caused by debris or freezing can cause automatic shutdown of the boiler. If you suspect freezing and the pipe run is accessible, you can try to free the obstruction by pouring hot water over the exposed pipe and clearing any blockage from the end of the pipe. If this fails to remedy the problem, you should contact your service engineer.

### 3.6 FROST PROTECTION

Your installer may have fitted a frost thermostat. If not and you are likely to be away for a short time, leave the boiler on with the boiler thermostat set at a low setting.

If the boiler is not going to be used for longer periods of time, the boiler and system should be drained.

Contact your service engineer for draining and filling the system.

## ! NOTE !

**We recommend that both antifreeze and corrosion inhibitor be used in the primary water system.**

### 3.7 FAILURE OF ELECTRICITY SUPPLY

If the electricity supply fails, the boiler will not operate. It should relight automatically when the supply is restored.

If a programmer is fitted, it will retain the time settings for up to 24 hours and will not have to be reset to the correct time of day when the supply is restored.

The programmer display will remain for up to 1 hour in the event of an electricity supply failure, and will re-appear when the supply is restored.

### 3.8 CLEANING YOUR BOILER

Lightly wipe over the case with a damp cloth and a little detergent and dry completely.

Do not use abrasive pads or cleaners.

Take care not to touch any hot surfaces.

## 4 AFTER SALES SUPPORT

If your boiler breaks down during the guarantee period, in the first instance you should contact your installer to identify the cause of the problem and if necessary your installer will contact us.

If you are unable to contact your installer please telephone the Grant UK Service Department for assistance. Authorisation to carry out guarantee repairs must be obtained from Grant UK before any work is carried out.

Costs incurred by unauthorised work will not be covered by Grant UK.

To contact the Grant UK customer support team, please call: 01380 736920.

If you need to contact Grant UK, please have the following information available:

- The address at which the installed boiler is located and the name of the householder.
- Details of the fault and any checks you may have carried out.
- Details of the installer and any competent persons who may have carried out work on the install in the past (if possible)



# 5 SERVICE LOG

<b>Service 1</b>	Date
	Engineer
	Company name
	Telephone number
	OFTEC Technician number
	Comments
	Signature

<b>Service 5</b>	Date
	Engineer
	Company name
	Telephone number
	OFTEC Technician number
	Comments
	Signature

<b>Service 2</b>	Date
	Engineer
	Company name
	Telephone number
	OFTEC Technician number
	Comments
	Signature

<b>Service 6</b>	Date
	Engineer
	Company name
	Telephone number
	OFTEC Technician number
	Comments
	Signature

<b>Service 3</b>	Date
	Engineer
	Company name
	Telephone number
	OFTEC Technician number
	Comments
	Signature

<b>Service 7</b>	Date
	Engineer
	Company name
	Telephone number
	OFTEC Technician number
	Comments
	Signature

<b>Service 4</b>	Date
	Engineer
	Company name
	Telephone number
	OFTEC Technician number
	Comments
	Signature

<b>Service 8</b>	Date
	Engineer
	Company name
	Telephone number
	OFTEC Technician number
	Comments
	Signature

<b>Service 9</b>	Date
	Engineer
	Company name
	Telephone number
	OFTEC Technician number
	Comments
Signature	

<b>Service 13</b>	Date
	Engineer
	Company name
	Telephone number
	OFTEC Technician number
	Comments
Signature	

<b>Service 10</b>	Date
	Engineer
	Company name
	Telephone number
	OFTEC Technician number
	Comments
Signature	

<b>Service 14</b>	Date
	Engineer
	Company name
	Telephone number
	OFTEC Technician number
	Comments
Signature	

<b>Service 11</b>	Date
	Engineer
	Company name
	Telephone number
	OFTEC Technician number
	Comments
Signature	

<b>Service 15</b>	Date
	Engineer
	Company name
	Telephone number
	OFTEC Technician number
	Comments
Signature	

<b>Service 12</b>	Date
	Engineer
	Company name
	Telephone number
	OFTEC Technician number
	Comments
Signature	

<b>Service 16</b>	Date
	Engineer
	Company name
	Telephone number
	OFTEC Technician number
	Comments
Signature	

# NOTES



**GRANT ENGINEERING (UK) LIMITED**

Hopton House, Hopton Industrial Estate, Devizes, Wiltshire, SN10 2EU  
Tel: +44 (0)1380 736920 Fax: +44 (0)1380 736991  
Email: [info@grantuk.com](mailto:info@grantuk.com) [www.grantuk.com](http://www.grantuk.com)