



Vortex Oil Boiler Ranges

Including Vortex boilers,
energy management systems
& EZ-Fit flue guide





Grant Engineering has been designing and manufacturing reliable, efficient and innovative heating products since 1978. Specialising in condensing oil-fired boilers and an expanding range of renewable appliances including air source heat pumps, solar thermal systems and hybrid technologies, the Grant brand has established a reputation for quality that is second to none.

Here at Grant, we combine precision engineering, innovation, performance and value for money to produce sustainable heating solutions that are trusted by installers and homeowners alike. While the technology is sophisticated, Grant products are easy to install, straightforward to maintain and backed-up by excellent after-sales support. When customers choose Grant, they also get the added peace of mind that comes with the excellent reliability and superb efficiencies of our products.

At the heart of everything we do is continuous product development. Every Grant product incorporates the latest technologies and materials which enable them to exceed performance and environmental standards ensuring that they make the best use of our natural resources. Consequently, Grant products meet the heating needs of tomorrow, today.

Contents

Introducing the range	4
Vortex oil boiler range	8
Vortex Eco utility range	10
Vortex Eco utility system range	11
Vortex Eco external range	12
Vortex Eco external system range	13
Vortex Eco internal wall hung range	14
Vortex Eco external wall hung range	15
Vortex Pro utility range	16
Vortex Pro utility system range	17
Vortex Pro external range	18
Vortex boiler house range	19
Vortex Pro internal combi range	20
Vortex Pro external combi range	21
Technical Specifications	22
Vortex Eco utility range	22
Vortex Eco external range	23
Vortex Eco wall hung range	24
Vortex Pro utility range	25
Vortex Pro external range	26
Vortex Pro combi range	27
Vortex boiler house range	28
Mag One central heating filter	29
Energy Management	30
QR Cylinders	39
Aftercare Support	40
Guarantees	41
EZ-Fit Flues	42
Yellow low level system	44
White high level system	46
White vertical system	48
Red balanced flexi system	50
Green external high level system	52
Orange conventional flexi system	54
Orange/Green hybrid systems	56

Biofuel Ready

Low carbon liquid fuels could play a significant role in helping off-gas properties operate cleaner, more sustainable home heating in the future. Extensive trials have been undertaken researching the potential of biofuels, exploring how they perform in operation in domestic heating systems compared to traditional fossil fuels. Biofuels can vary from blended fuels, such as B30K which combines 70% kerosene with 30% Fatty Acid Methyl Ester (FAME), and 100% biofuels such as Hydrotreated Vegetable Oil (HVO). It is hoped that low carbon liquid fuels such as HVO will help parts of the UK to transition into low carbon heating systems.

HVO biofuel is a type of renewable energy made from organic matter and waste materials and, as it is a second-generation fuel, it eliminates up to 85% of net carbon dioxide emissions compared with traditional fossil fuels, as well as achieving lower NOx emissions. HVO can be used as a 'drop-in fuel' so it is a suitable replacement for existing fossil fuels like kerosene. Field trials are continuing, with homes and commercial properties trialling the use of HVO biofuel in oil-fired boilers, trials that Grant Engineering have been involved in with their Vortex boilers successfully working with the HVO biofuel.

In preparation for the wider availability of biofuels, all new Grant Vortex floor standing oil-fired boilers are HVO compatible (recommissioning would be required). Homeowners who choose a Grant boiler can therefore be assured that their boiler is operating today at the highest efficiencies it can using standard kerosene oil while also being ready to operate with impressive efficiencies in the future using HVO biofuel when its availability increases.

When the time arises to switch from kerosene oil to biofuel, homeowners will simply need to ask their installer to make some alterations to their Grant boiler's operation which can be completed during an annual service. Other changes may need to be made elsewhere on the heating system to accommodate the new fuel but the majority of the system equipment will be biofuel compatible too. This, combined with a Grant biofuel ready oil boiler, should make the switch from kerosene oil to biofuel seamless and straightforward for rural, hard to heat homes.

Discover more about biofuels grantuk.com/knowledge-hub/education-area/biofuels



Introducing the Range

Grant's Vortex oil-fired boiler range consists of internal, external, boiler house, combi and wall hung models. Incredibly efficient and incorporating the latest low NOx burner technology, every Vortex oil boiler has been designed to deliver reliable home heating as sustainably as possible. The range delivers flexibility when it comes to installation. From white cased utility models through to durable powder-coated external variants, the Vortex range of oil-fired boilers provides customers with choice, enabling them to select the solution which best meets their specific requirements.

Grant UK also supply a comprehensive range of flue systems which are designed to ensure that plumbing is kept well out of the way of windows, air vents or doors, and out of sight. Low level balanced, high level, or vertical flue kits are available as well as solutions that can convert an existing low level balanced flue to an external high level or vertical arrangement. More information on the EZ-Fit flues can be found on page 42 of this brochure.

Also available on the Grant UK website is a flue configurator tool which helps you identify the most suitable flue system for your chosen boiler. Simply scan the code to go directly to this handy tool.



FLUE CONFIGURATOR



“Grant Oil Boiler recommended by our installer, the fitting went very straight forwardly and the boiler works perfectly.”



by Robert Hooker

Rated 4.3 / 5 | 2,064 reviews ★ Trustpilot

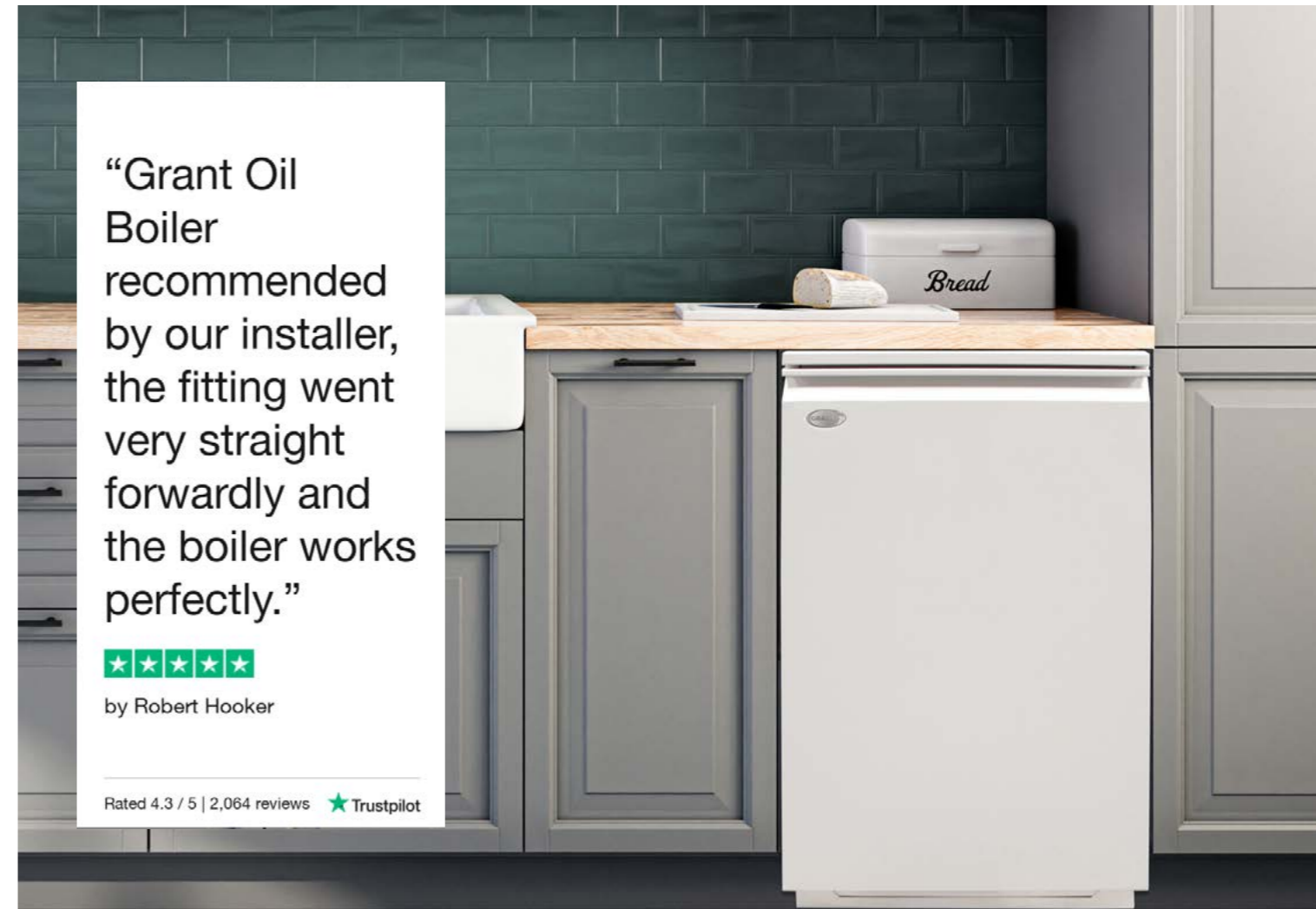

Efficiency

Designing and manufacturing highly efficient heating products has always been central to Grant's R&D processes. Since their first oil boiler, each generation has introduced technological advances which enable the products to be as efficient as possible. This is why the Vortex boilers of today are some of the most efficient models available on the market.

Installing a high efficiency oil boiler offers homeowners multiple benefits. The appliances which work most efficiently and effectively use less fuel which in turn can reduce heating bills for the householder. Not only does the reduced fuel usage result in lower heating and hot water running costs, but it is also more sustainable. The lower fuel demand enables householders to stretch their oil further and to enjoy the advantages that this delivers.

Efficiency through design

Grant's oil boilers incorporate several design features which enable each model to work most efficiently. Each boiler utilises the patented Vortex stainless steel condensing heat exchanger and turbulator baffle system, enabling the boilers to extract energy from the latent heat which would normally be lost through the flue. This award-winning

technology has been recognised throughout the industry and is one of the reasons why Grant boilers are so popular with engineers and householders alike.

The quality of the components within Grant's Vortex models is never compromised either. Within each boiler is the latest burner technology, burners which have undergone significant advances in design in recent years. Developed to atomise oil as efficiently as possible, modern day pressure jet burners achieve excellent combustion efficiencies. In addition, these burners are all low NOx, delivering high performances with lower emissions levels.

By combining market leading technologies which are tried and trusted, Grant's oil boilers are able to deliver home heating effectively and reliably for many years.



Efficiency in practise

ErP ratings and SAP 2009 figures are two standards which measure a product's efficiency. The Energy related Products (ErP) labelling provides homeowners with a clear rating which indicates the efficiency level of an appliance. Oil boilers must meet certain energy efficiency criteria in order to achieve a rating between A (most efficient) down to D (least efficient). Heat only boilers have one ErP rating whereas combination boilers have two ErP ratings, one for their heating efficiency and one for their hot water efficiency.

Meanwhile, SAP 2009 is an energy performance calculation which produces a rating which is based upon the energy costs associated with space heating, water heating, ventilation and lighting less cost savings from energy generation technologies. The rating can be between 1 to 100, with the higher figures indicating lower running costs.

All of Grant's oil boilers have an ErP 'A' rating for their heating and SAP 2009 efficiency figures which recognise that Vortex models can achieve annual efficiencies of up to 93.3% gross. With these figures, Grant can verify that each of their oil boilers puts into practice what it is designed to do.

Improving system efficiency

Today, there are many different ways that householders can make their home heating system work as efficiently as possible, from choosing the right heat source through to effective controls and regular product maintenance.

Upgrade the heat source and combine technologies

Replacing an old, inefficient boiler with a new condensing Vortex oil-fired boiler can instantly help reduce fuel consumption. Householders can further improve their system's efficiency by opting to install a high-performance hot water cylinder alongside their new boiler. Models such as Grant's QR cylinders are designed to deliver maximum heat transfer as well as low standing heat losses to reliably and effectively meet a property's hot water needs.

Householders can further reduce their fuel usage but installing solar thermal as well. Grant Sahara Solar Thermal systems work all year round, utilising energy from the sun to sustainably heat water. Combining solar thermal technology with a highly efficient cylinder can help reduce the overall demand on the oil boiler, further reducing the amount of fuel used.

Correct system design

It is essential that the right boiler size is selected to meet the heating requirements of a property. Installing too small a boiler will cause numerous problems for both the householder and their heating system. Meanwhile, oversizing a system and installing too large a boiler is highly inefficient because the boiler's output will be greater than what the property requires. This is why correct system design is so important and crucial for achieving maximum system efficiency throughout a home.

Complete commissioning process

Alongside correct system design and installation, the commissioning process is also central to ensuring that a boiler works at its most efficient rate. Commissioning a boiler involves balancing the radiators and setting up the pumps, two factors which can contribute to how well a boiler works. If a boiler is not correctly commissioned, this can prevent it from achieving the efficiencies it is capable of.

Effective controls

Modern day control systems can help homeowners to precisely manage their home heating, achieving maximum comfort with improved efficiencies. Room thermostats and controls deliver heat when and where it is most needed, reducing the demand when not required which consequently reduces the demand on the boiler. In addition, weather compensators such as the Grant GEO360 can adjust system water temperature to match a heat output closer to the needs of the home which can also help save fuel.

Routine servicing

Regularly maintaining an oil boiler with routine servicing is beneficial in many ways. It is recommended that Grant oil boilers are serviced every twelve months to help prolong the lifespan of the product. In addition, servicing involves checking the system as well, ensuring that both the boiler and system are operating safely and efficiently.



Vortex Oil Boiler Range

The Vortex condensing oil boiler range has been developed by Grant to combine quality, reliability and exceptional performance. Each model within the range has been designed to be straightforward to install, user-friendly to operate and maintain, while also achieving excellent efficiencies to meet a home's heating requirements effectively. With so much choice, the Vortex range of floor standing and wall hung boilers offers homeowners a broad selection of models to suit a kitchen, utility, outdoor or garage environment.



Vortex Eco Utility Range

The Vortex Eco Utility range of competitively priced condensing boilers have a simplified casing, control panel and pipework arrangement. The ideal choice for utility room installations, the Eco Utility models incorporate Grant's patented stainless steel heat exchanger, are quiet in operation and simple to service with the burner and combustion chambers positioned towards the front of each boiler.

Models

- VTXECO15/21 Vortex Eco Utility 15-21kW
- VTXECO21/26 Vortex Eco Utility 21-26kW
- VTXECO26/35 Vortex Eco Utility 26-35kW

- 15kW – 35kW outputs available
- Factory fitted condensate trap within the boiler case (can be positioned externally if preferred)
- Can be flued from the top, rear, left or right hand side of appliance

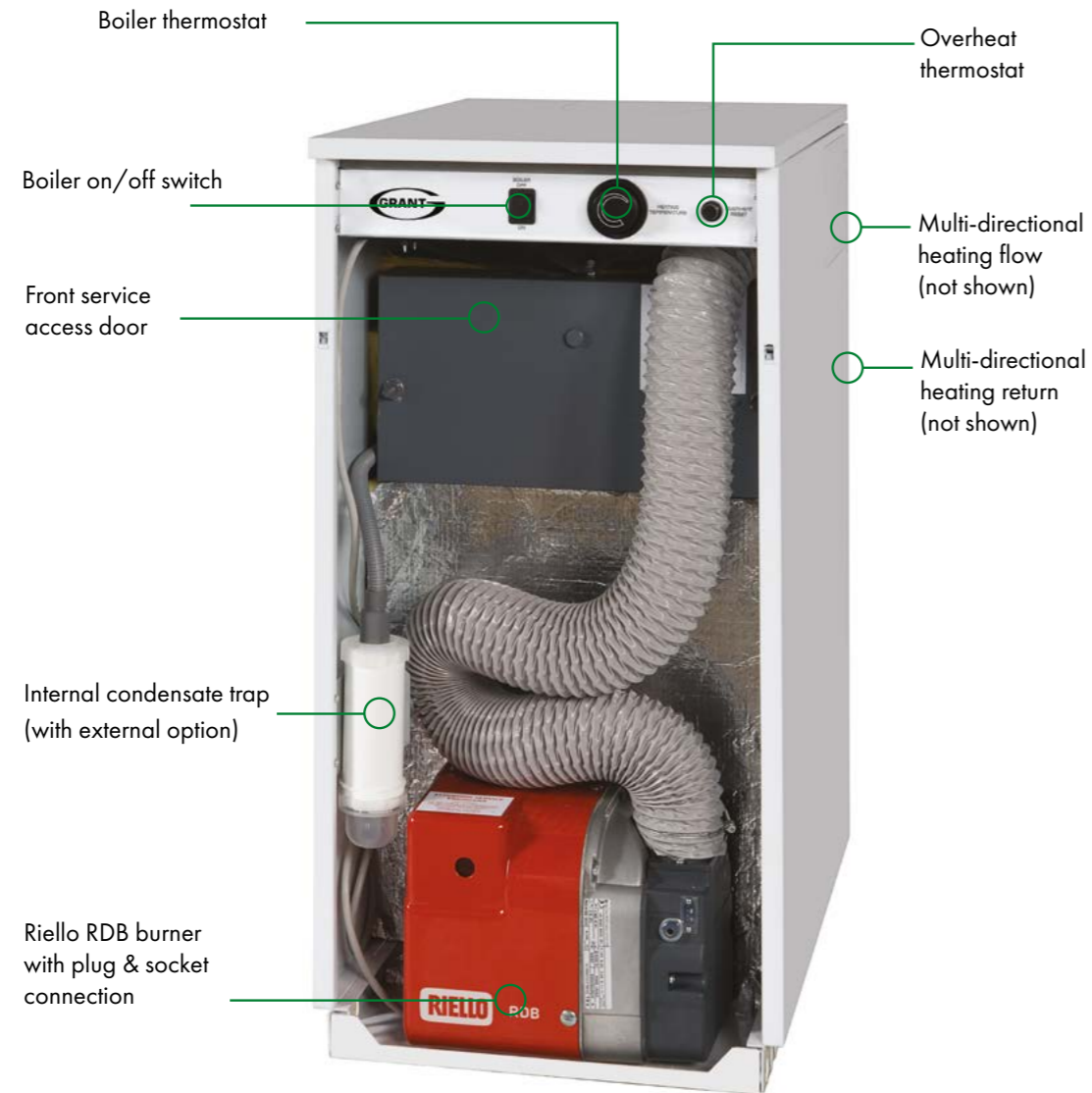

*When installed by a G1 Installer. Subject to full T&C's.

Model shown: VTXECO15/21

Vortex Eco System Utility Range

All three Vortex Eco Utility boilers are available as sealed system versions. Eco Utility System models are supplied with a factory fitted expansion vessel, filling loop, pressure gauge, automatic air vent, pressure relief valve and high efficiency circulating pump enabling the boilers to be installed without the need for a feed and expansion tank in the loft.

Models

- VTXSECO15/21 Vortex Eco Utility System 15-21kW
- VTXSECO21/26 Vortex Eco Utility System 21-26kW
- VTXSECO26/35 Vortex Eco Utility System 26-35kW

- 15kW – 35kW outputs available
- Factory fitted 12 litre expansion vessel
- Wilo high efficiency pump fitted within boiler casing

Please note, system models require top service access so this must be accounted for during installation.

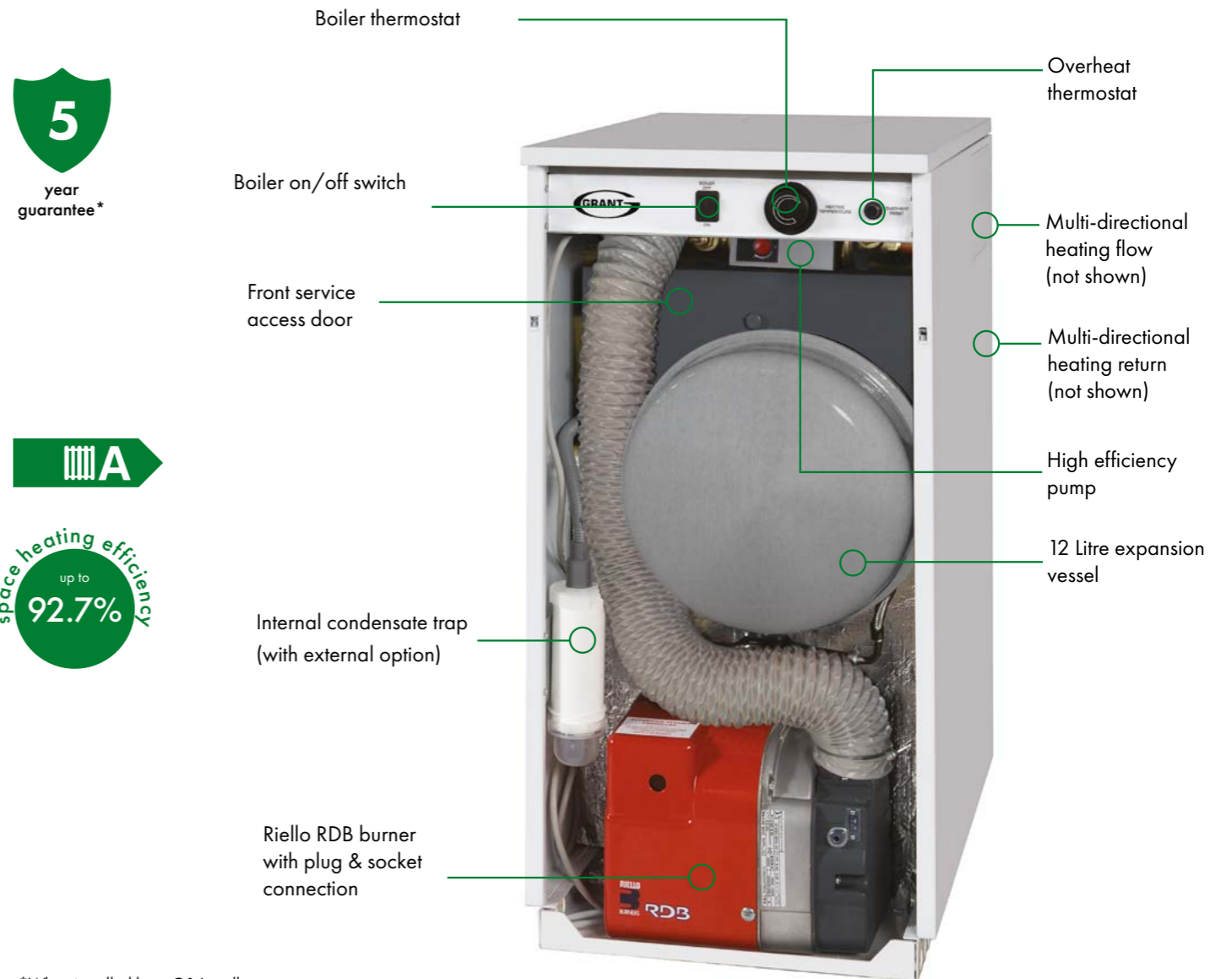

*When installed by a G1 Installer. Subject to full T&C's.

Model shown: VTXSECO15/21

Vortex Eco External Range

When space is at a premium indoors, an external boiler can provide the solution. Grant's Vortex Eco External boilers are competitively priced, highly efficient and with their durable powder coated casing, are designed and built to be sited outside of a property. All the Vortex Eco External models have multi-directional flueing options providing flexibility when it comes to installation.

Models

- VTXOMECO15/21 Vortex Eco External 15-21kW
- VTXOMECO21/26 Vortex Eco External 21-26kW
- VTXOMECO26/35 Vortex Eco External 26-35kW

- 15kW – 35kW outputs available
- High quality external powder coated pain finish
- Built-in boiler frost protection, mains isolating switch and test switch



*When installed by a G1 Installer. Subject to full T&C's.

Model shown: VTXECO15/21

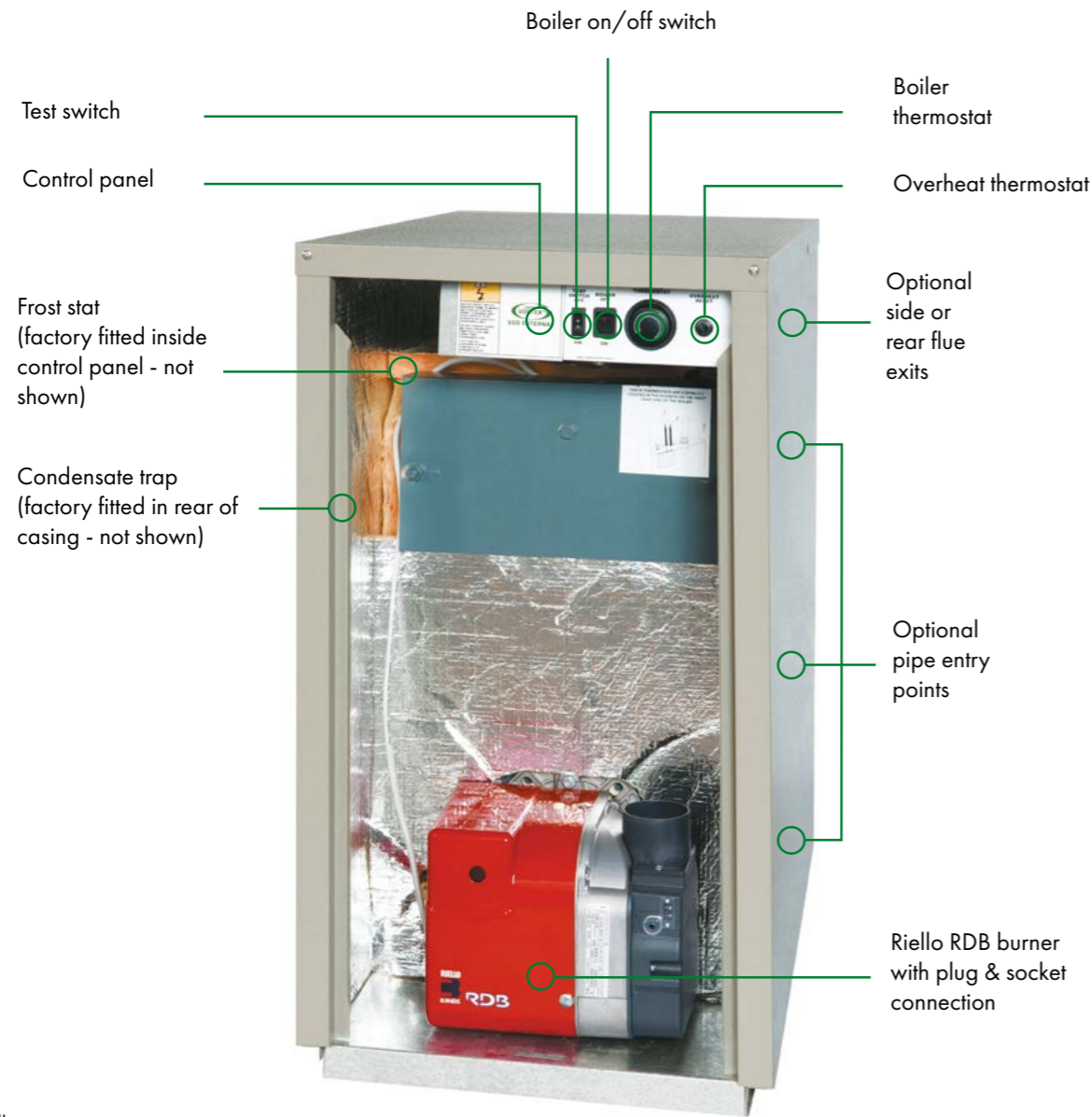

Vortex Eco External System Range

The Vortex Eco External System boiler range consists of three models which are also supplied with a high quality external powder coated paint finish. Similar to the Eco Utility System range, all of the Eco External System boilers include a factory fitted expansion vessel, filling loop, pressure gauge, automatic air vent, pressure relief valve and high efficiency circulating pump.

Models

- VTXSOMECO15/21 Vortex Eco External System 15-21kW
- VTXSOMECO21/26 Vortex Eco External System 21-26kW
- VTXSOMECO26/35 Vortex Eco External System 26-35kW

- 15kW – 35kW outputs available
- Multi-directional flue options
- Built-in boiler frost protection, mains isolating switch and test switch



*When installed by a G1 Installer. Subject to full T&C's.

Model shown: VTXSECO15/21

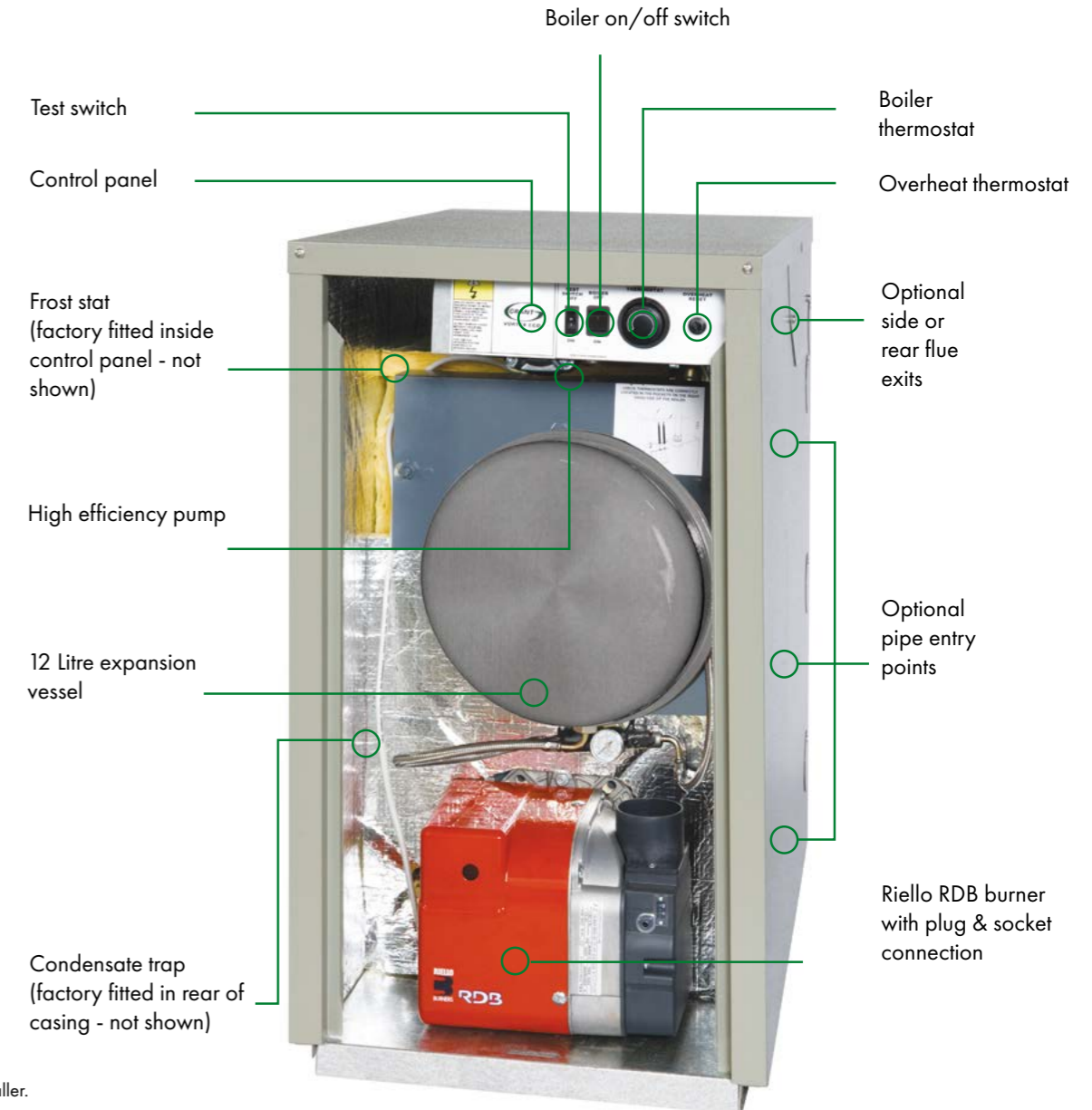

Vortex Eco Internal Wall Hung Range

Grant's popular Internal Wall Hung boilers are sleek, white cased models suitable for when a floor standing model cannot be accommodated. Available in open-vented system and sealed system variants, the Vortex Internal Wall Hung range is supplied pre-plumbed and features Grant's patented heat exchanger and turbulator baffle system.

Models

VTXWH16/21 Vortex Wall Hung Internal 16-21kW
 VTXSWH16/21 Vortex Wall Hung Internal System 16-21kW

- 16kW – 21kW outputs available
- Sealed system models available
- Compatible with all Grant EZ-Fit low level, high level and vertical flue systems (purchased separately)



*When installed by a G1 Installer. Subject to full T&C's.

Model shown: VTXWH16/21

Vortex Eco External Wall Hung Range

The Vortex Eco External Wall Hung range consists of an open-vented system model and a sealed system model. Similar to the Internal Wall Hung models, the External Wall Hung boilers are also pre-plumbed. Each model is finished with a high quality external powder coated paint and has a factory fitted flue.

Models

VTXOMWH16/21 Vortex Wall Hung External 16-21kW
 VTXSOMWH16/21 Vortex Wall Hung External System 16-21kW

- 16kW – 21kW outputs available
- Sealed system models available
- Built-in boiler frost protection, mains isolating switch and test switch

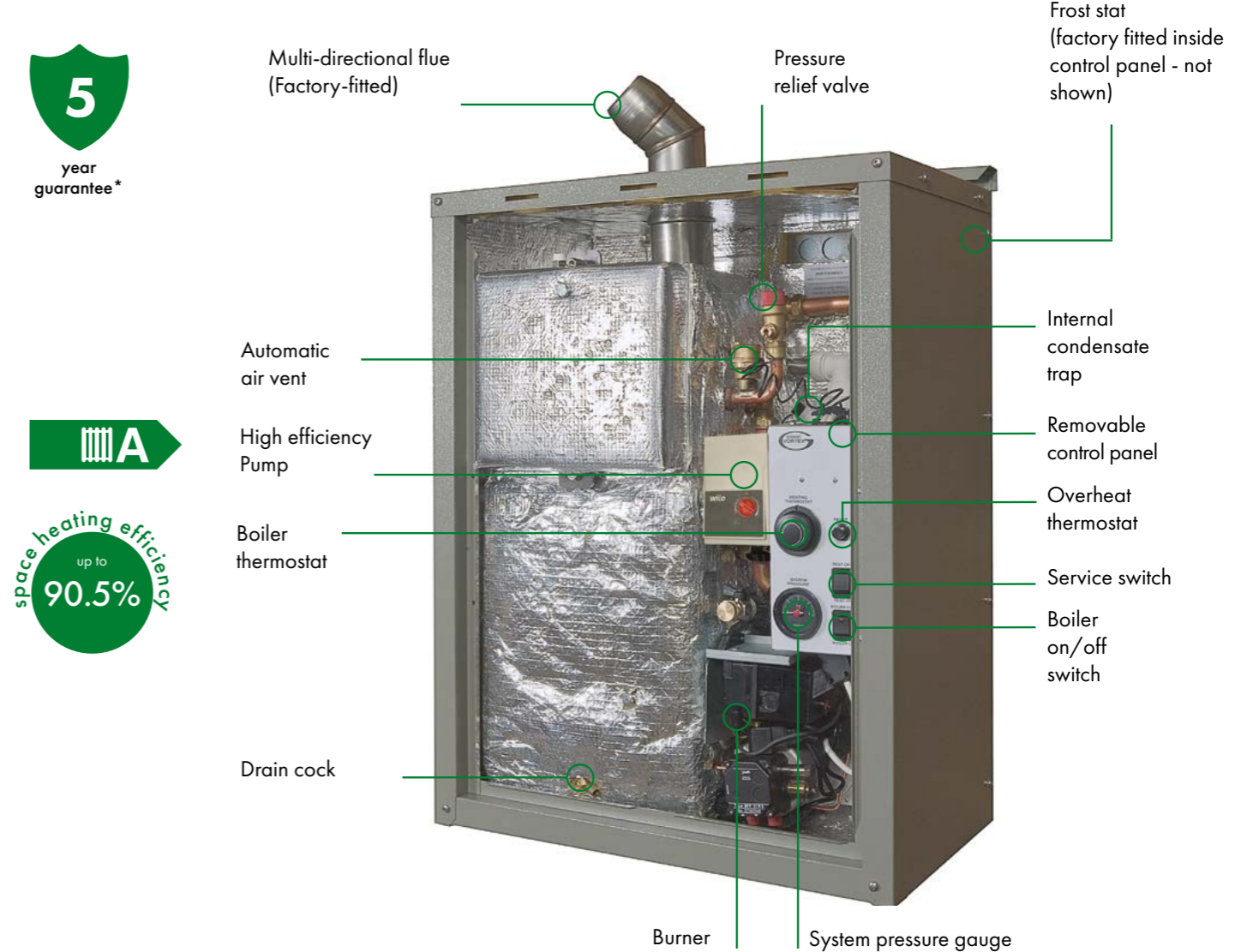

*When installed by a G1 Installer. Subject to full T&C's.

Model shown: VTXSOMWH16/21

Vortex Pro Utility Range

Grant's Vortex Pro Utility boilers are incredibly efficient, achieving efficiencies of up to 93.3%. Designed for the kitchen or a utility room, the Pro Utility models deliver choice and performance across the range. Compact in size these models can be an ideal solution for direct boiler replacements of older oil-fired models.

Models

VTX15/26 Vortex Pro Utility 15-26kW

VTX26/46 Vortex Pro Utility 26-46kW

VTX46/70 Vortex Pro Utility 46-70kW

- 15kW – 70kW outputs available
- Factory fitted condensate trap within the boiler case (can be positioned externally if preferred)
- Exceptionally quiet in operation

10
year
guarantee*

A

space heating efficiency
up to
91.7%

*When installed by a G1 Installer.
Subject to full T&C's.

Model shown: VTX15/26



Vortex Pro System Utility Range

Two sealed system boiler models are available in the Pro Utility System range which include the supply of a factory fitted expansion vessel, filling loop, pressure gauge, automatic air vent, pressure relief valve and high efficiency circulating pump. As with all Grant boilers, these models are straightforward to install and maintain.

Models

VTXS15/26 Vortex Pro Utility System 15-26kW

VTXS26/46 Vortex Pro Utility System 26-46kW

- 15kW – 46kW outputs available
- System pressure gauge display in control panel

10
year
guarantee*

A

space heating efficiency
up to
91.7%

*When installed by a G1 Installer.
Subject to full T&C's.

Model shown: VTXS15/26

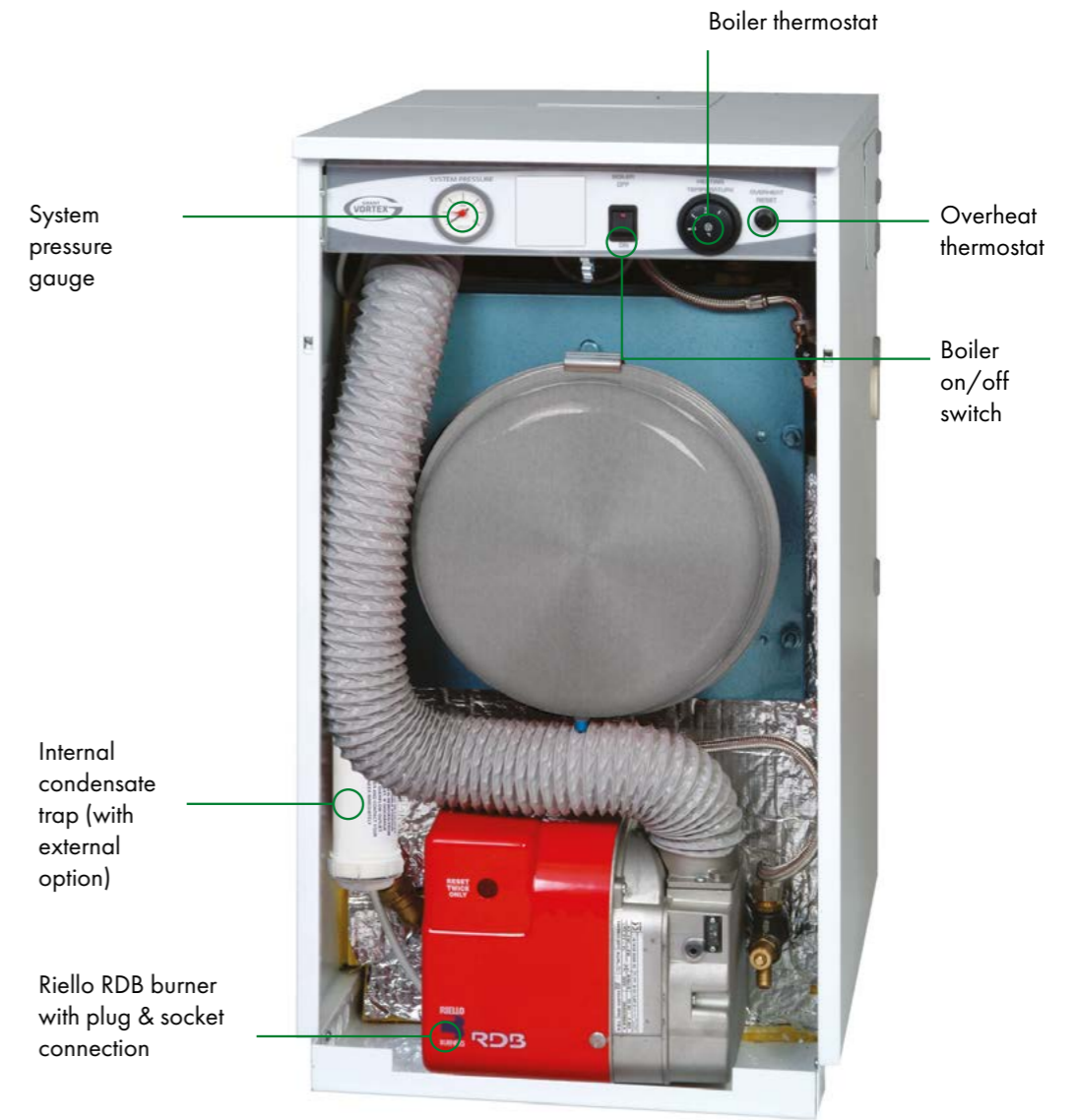

Vortex Pro External Range

The Vortex Pro External boilers incorporate all the high quality components featured in the Pro Utility Range within a powder coated external casing. Like the Pro Utility models, the Pro External boilers are exceptionally efficient and are some of the highest efficiency outdoor oil-fired boilers. When heating outputs of up to 70kW are required and the preferred boiler location is outside, the Vortex Pro External Range can deliver the solution.

Models

VTXOM15/26 Vortex Pro External 15-26kW

VTXOM26/46 Vortex Pro External 26-46kW

VTXOM46/70 Vortex Pro External 46-70kW

Sealed System Kits

VTXOMSSKIT26 Vortex Pro External S/S Kit 15-26kW

VTXOMSSKIT46 Vortex Pro External S/S Kit 26-46kW

- 15kW – 70kW outputs available
- Factory fitted frost stat and condensate trap
- Sealed system kits available for all models**

10
year
guarantee*

A

space heating efficiency
up to
91.7%

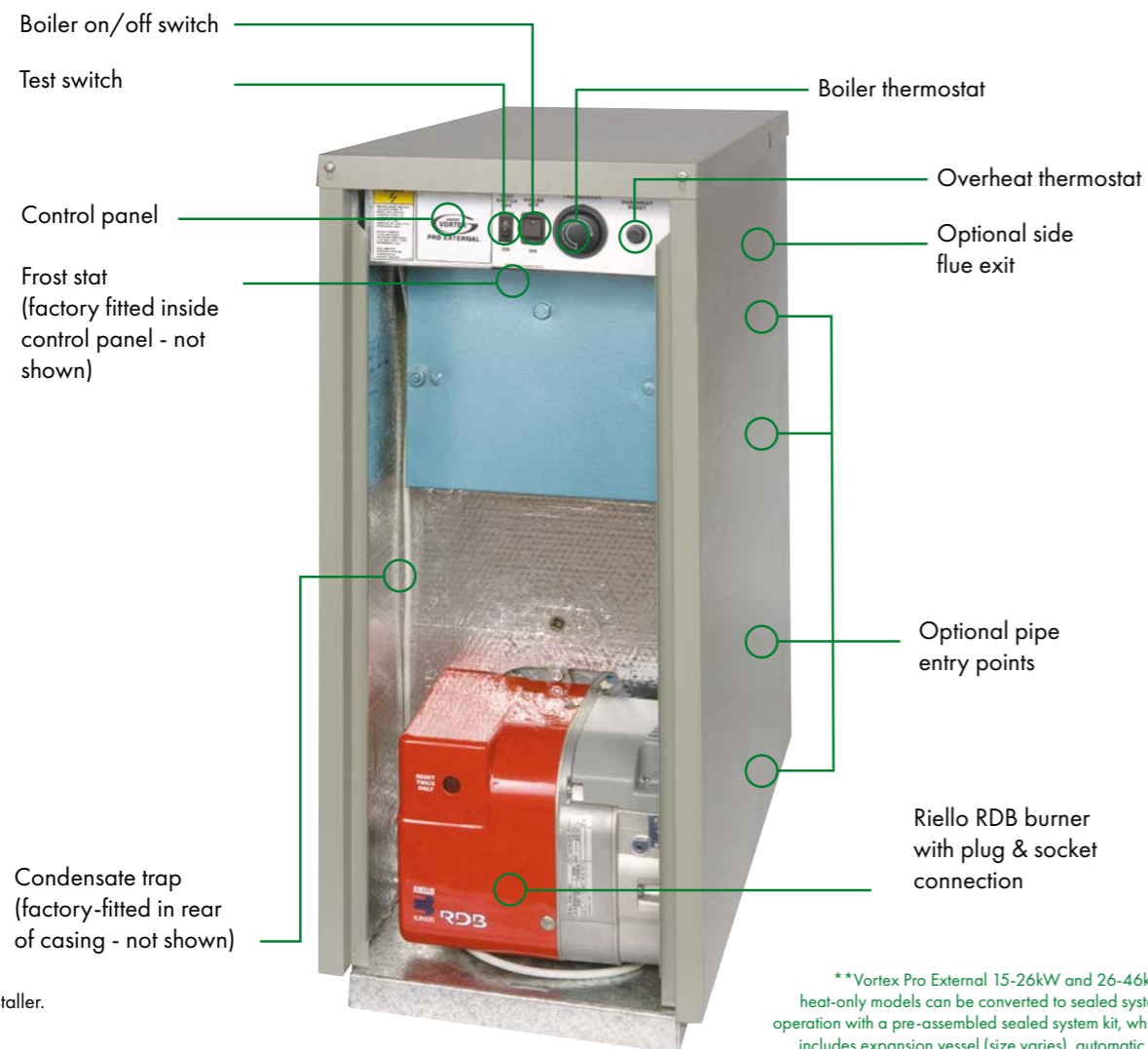

**Vortex Pro External 15-26kW and 26-46kW heat-only models can be converted to sealed system operation with a pre-assembled sealed system kit, which includes expansion vessel (size varies), automatic air vent, pressure relief valve and circulating pump. A filling loop and pressure gauge are also included and these can be fitted within the module casing or, ideally, in a convenient site within the property located between the cold main and central heating return.

*When installed by a G1 Installer. Subject to full T&C's.

Model shown: VTXOM15/26

Vortex Boiler House Range

Featuring an externally mounted Riello RDB burner and dual thermostat, the Vortex Boiler House models are ideal for locations which are difficult to access and where a white cased utility boiler is not always the best solution. The Vortex Boiler House range encompass the same unique heat exchangers and turbulator baffle system used in Grant's other oil boilers. Consequently, Grant's Boiler House models have ultra-high efficiencies and low running costs.

Models

VTXBH15/26 Vortex Boiler House 15-26kW

VTXBH26/46 Vortex Boiler House 26-46kW

VTXBH46/70 Vortex Boiler House 46-70kW

- 15kW – 70kW outputs available
- Distinctive red powder coated casing
- Compatible with all Grant EZ-Fit flue options and are flued in the same way as utility models

5
year
guarantee*

A

space heating efficiency
up to
91.7%

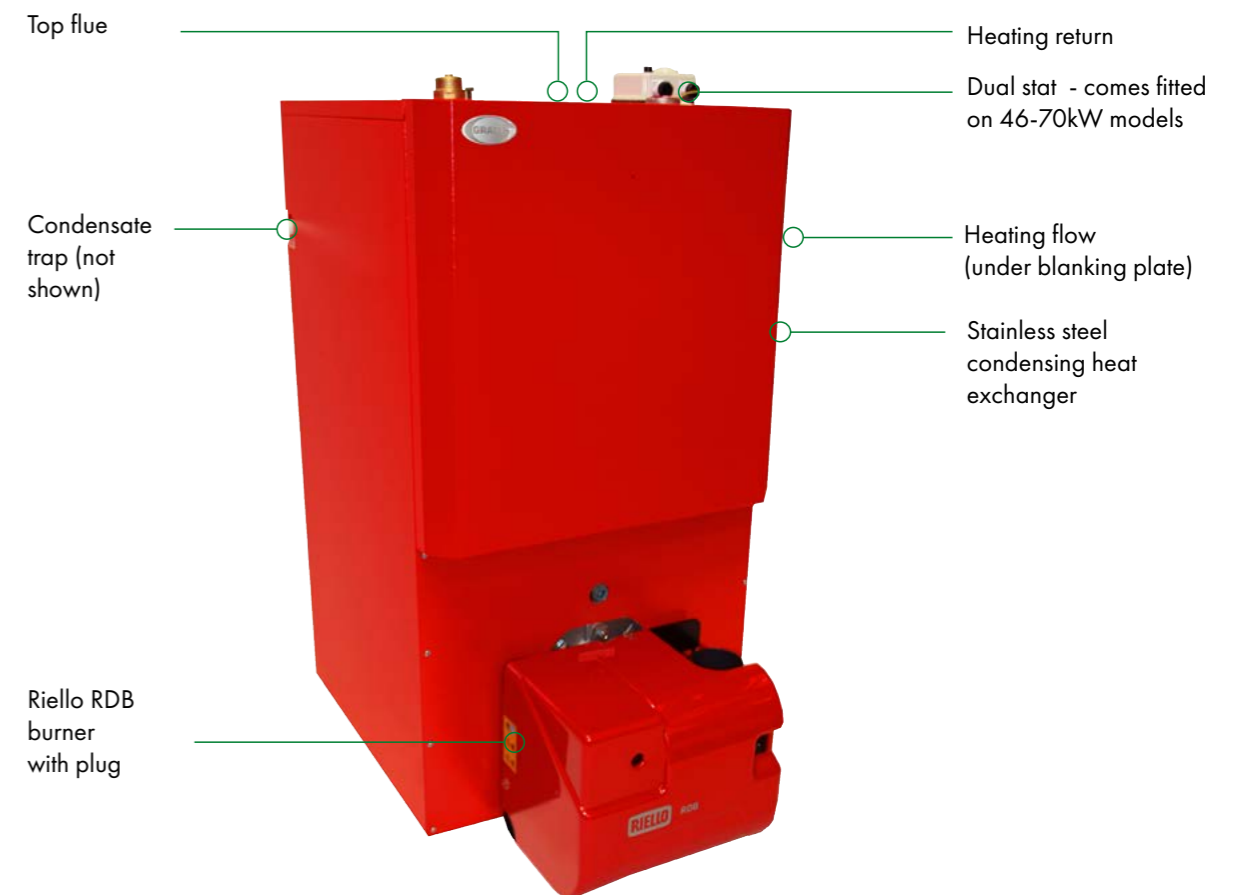

*When installed by a G1 Installer. Subject to full T&C's.

Model shown: VTXBH26/46

Vortex Pro Combi Range

Grant's Vortex Pro Combi boilers have been designed to increase hot water performance effectively and efficiently due to their large heat exchangers and accurate electronic temperature controls. Each Pro Combi internal model can operate in condensing mode for central heating while also maintaining instant hot water production. Reliable in operation and easy to install and service, the Vortex Pro Combi boilers are a popular choice for homeowners and their installers.

Models

- VTXCOMBI21 Vortex Internal Combi 21kW
- VTXXSCOMBI26 Vortex Internal Combi XS 26kW
- VTXCOMBI26 Vortex Internal Combi 26kW
- VTXCOMBI36 Vortex Internal Combi 36kW

- 21kW, 26kW and 36kW outputs available
- Slimline 515mm wide 26kW model available
- 24 litre expansion vessel supplied as standard

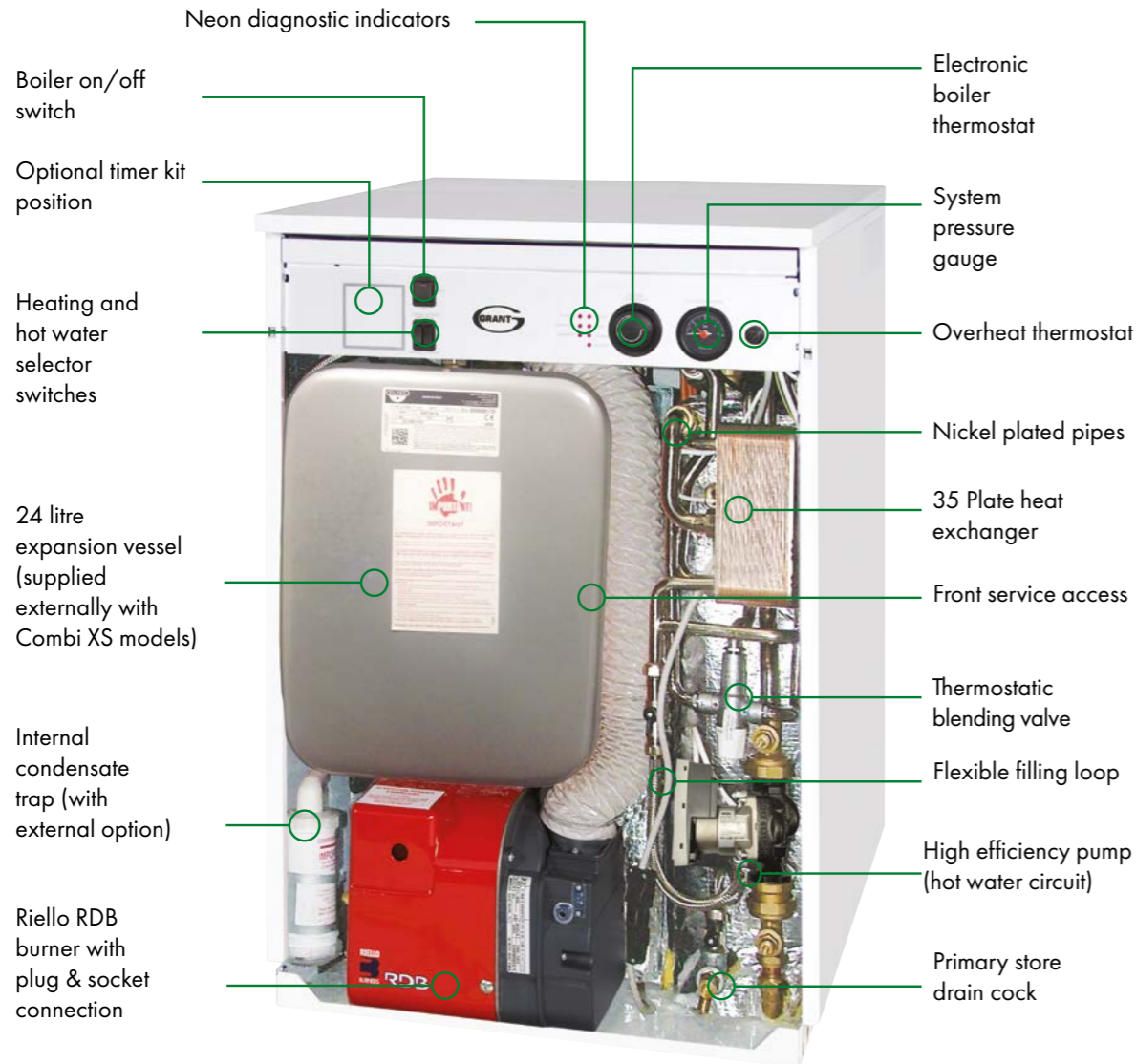

*When installed by a G1 Installer. Subject to full T&C's.

Model shown: VTXCOMBI26

Vortex Pro External Combi Range

The Vortex Pro External Combi boiler range comprises of three models. Each external combination boiler from Grant is supplied with a 24ltr expansion vessel as well as neon diagnostic indicators to allow for easy operation. The Pro External Combis, which have larger than normal heat exchangers, deliver excellent hot water performances and are highly efficient.

Models

- VTXOMCOMBI21 Vortex External Combi 21kW
- VTXOMCOMBI26 Vortex External Combi 26kW
- VTXOMCOMBI36 Vortex External Combi 36kW

- 21kW, 26kW and 36kW outputs available
- High quality external powder coated paint finish
- Features two accurate electronic temperature controls allowing for condensing mode operation for central heating while also maintaining instant hot water production

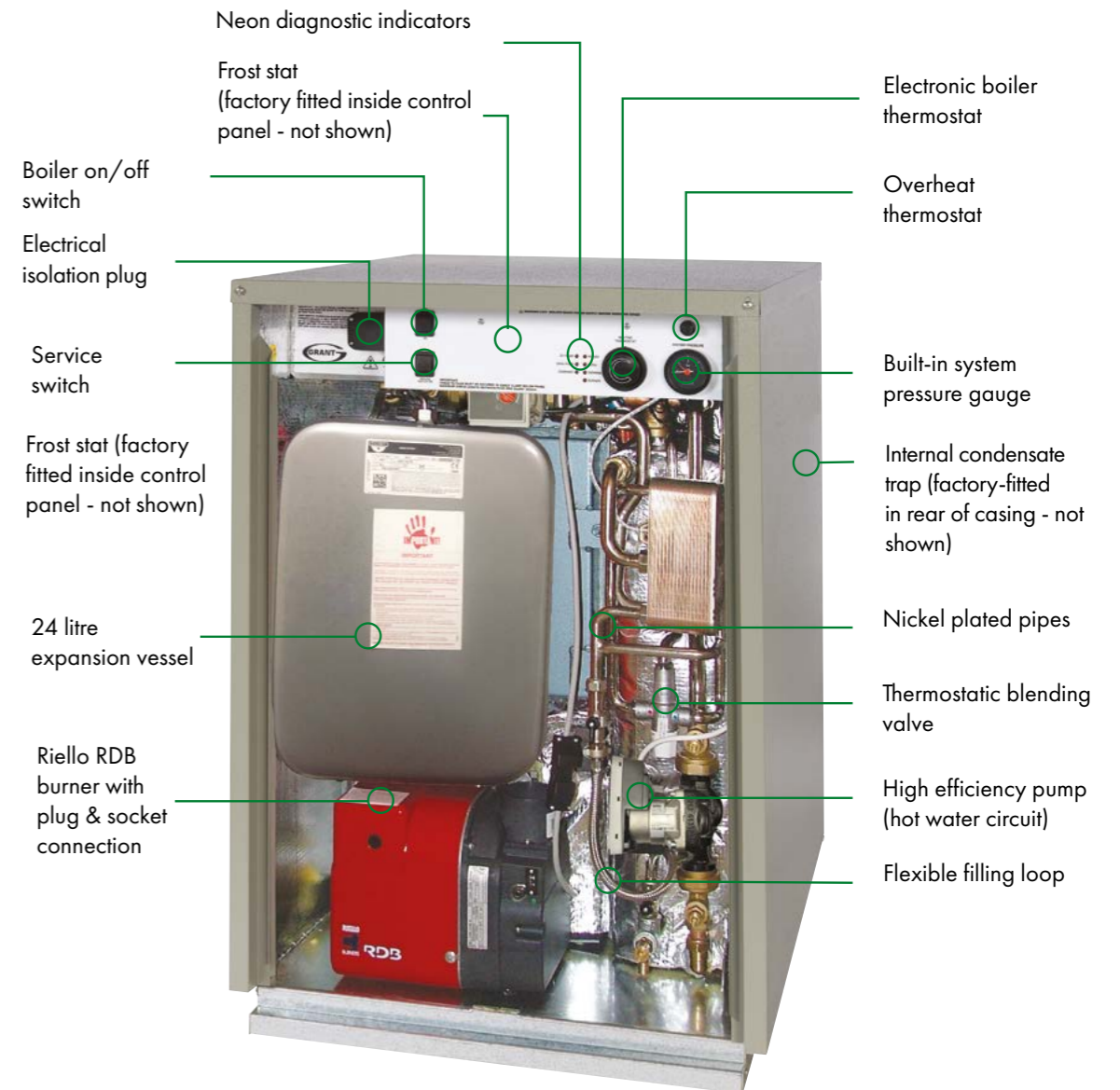

*When installed by a G1 Installer. Subject to full T&C's.

Model shown: VTXOMCOMBI26

Vortex Eco Utility Range Technical Specifications

Model	Output kW	Output Btu/h	Set Output kW	Flow Connection mm	Return Connection mm	Cold Water In mm	Pressure Relief mm	Weight (dry) kg
VTXECO15/21	15 - 21	50 - 70,000	21	22	22	n/a	n/a	97
VTXECO21/26	21 - 26	70 - 90,000	23.5	22	22	n/a	n/a	97
VTXECO26/35	26 - 35	90 - 120,000	31	22	22	n/a	n/a	127
VTXSECO15/21	15 - 21	50 - 70,000	21	22	22	15	15	123
VTXSECO21/26	21 - 26	70 - 90,000	23.5	22	22	15	15	123
VTXSECO26/35	26 - 35	90 - 120,000	31	22	22	15	15	138

Dimensions (mm)

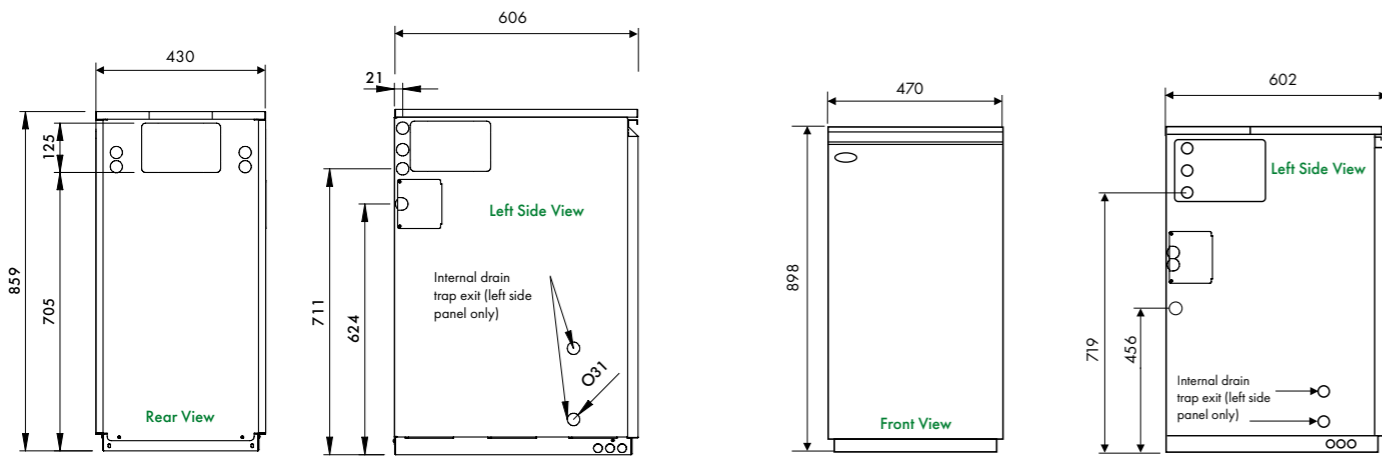

Vortex Eco 15-21, 21-26kW Utility and System

Vortex Eco 26-35kW Utility and System



Vortex Eco External Range Technical Specifications

Model	Output kW	Output Btu/h	Set Output kW	Flow Connection mm	Return Connection mm	Cold Water In mm	Pressure Relief mm	Weight (dry) kg
VTXOMECO15/21	15 - 21	50 - 70,000	21	22	22	n/a	n/a	113
VTXOMECO21/26	21 - 26	70 - 90,000	23.5	22	22	n/a	n/a	113
VTXOMECO26/35	26 - 35	90 - 120,000	31	22	22	n/a	n/a	142
VTXSOMECO15/21	15 - 21	50 - 70,000	21	22	22	15	15	136
VTXSOMECO21/26	21 - 26	70 - 90,000	23.5	22	22	15	15	136
VTXSOMECO26/35	26 - 35	90 - 120,000	31	22	22	15	15	152

Dimensions (mm)

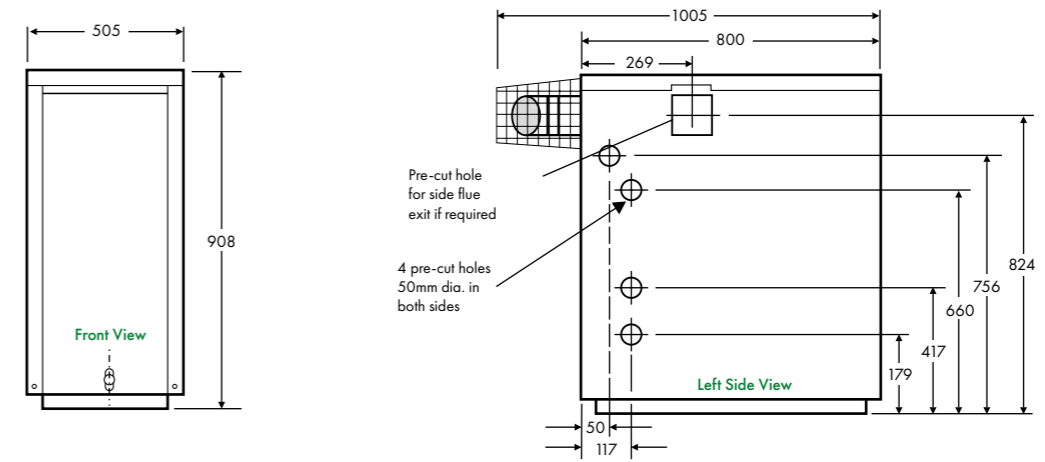

Vortex Eco 15-21, 21-26, 26-35kW External and External System



Vortex Eco Wall Hung Range Technical Specifications

Model	Output kW	Output Btu/h	Set Output kW	Flow Connection mm	Return Connection mm	Cold Water In mm	Pressure Relief mm	Weight (dry) kg
VTXWH16/21	16 - 21	55 - 70,000	18.7	22	22	n/a	n/a	85.7
VTXSWH16/21	16 - 21	55 - 70,000	18.7	22	22	15	15	97.5
VTXOMWH16/21	16 - 21	55 - 70,000	18.7	22	22	n/a	n/a	92.1
VTXSOMWH16/21	16 - 21	55 - 70,000	18.7	22	22	15	15	96.1

Dimensions (mm)

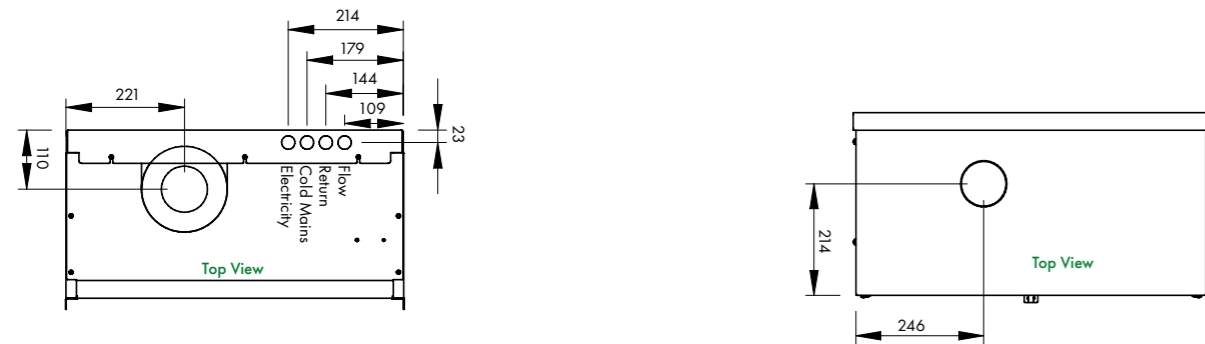
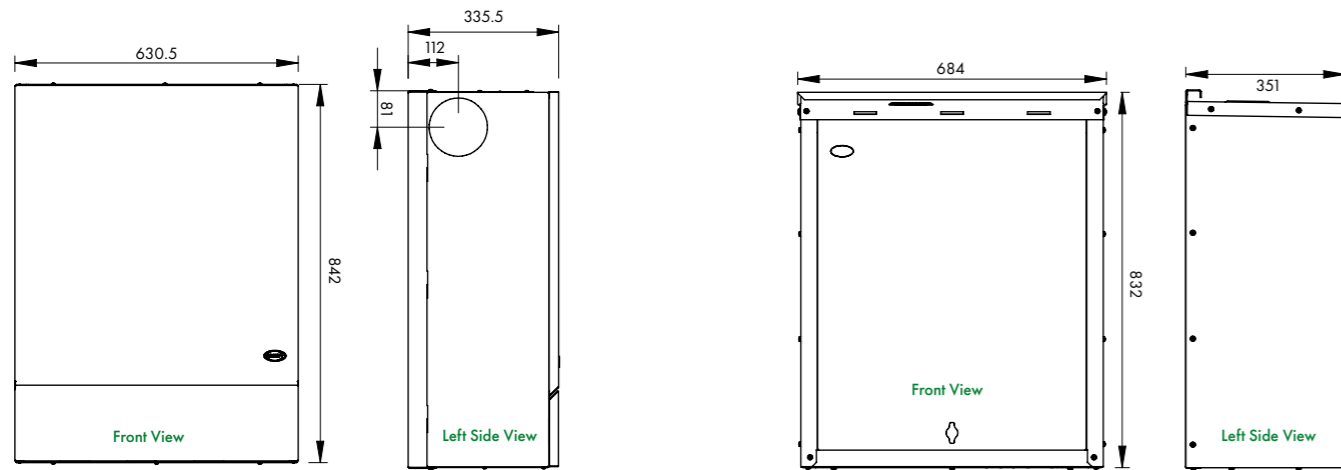

Vortex Eco Wall Hung and Wall Hung System
16-21kW Internal

Vortex Eco Wall Hung and Wall Hung System
16-21kW External

Vortex Pro Range Technical Specifications

Model	Output kW	Output Btu/h	Set Output kW	Flow Connection mm	Return Connection mm	Cold Water In mm	Pressure Relief mm	Weight (dry) kg
VTX15/26	15 - 26	50 - 90,000	21	22	22	n/a	n/a	130
VTX26/46	26 - 46	90 - 157,000	41	28	28	n/a	n/a	144
VTX46/70	46 - 70	157 - 240,000	64	1 1/4" BSP	1 1/4" BSP	n/a	n/a	282
VTXS15/26	15 - 26	50 - 90,000	21	22	22	15	15	138
VTXS26/46	26 - 46	90 - 157,000	41	28	28	15	15	168

Dimensions (mm)

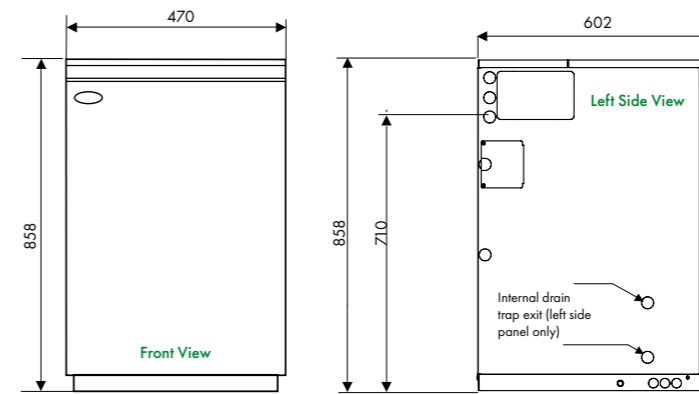

Vortex Pro and Pro System 15-26kW

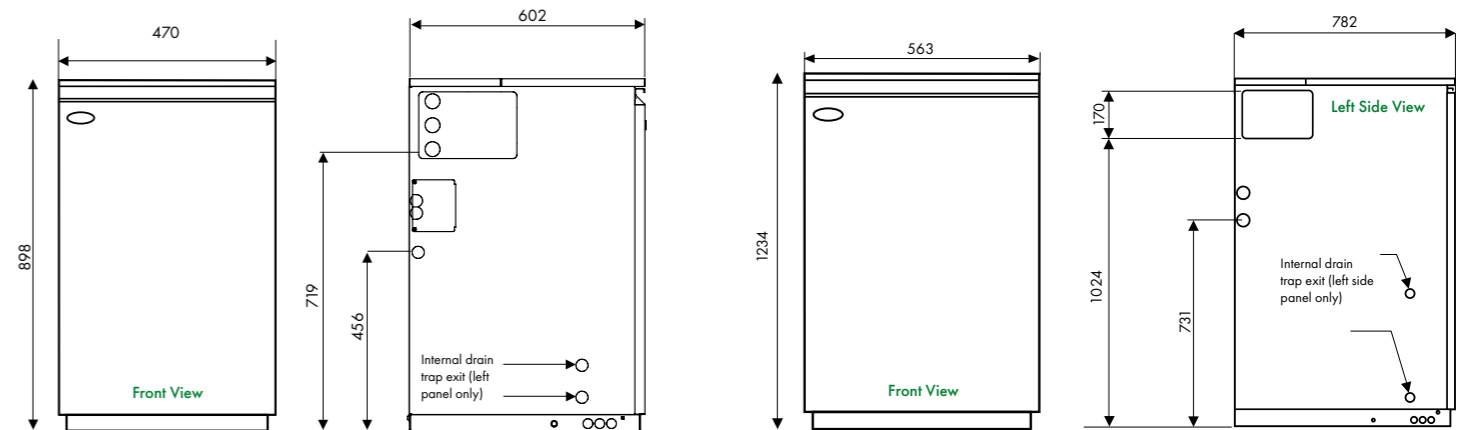

Vortex Pro and Pro System 26-46kW

Vortex Pro 46-70kW

Vortex Pro External Range Technical Specifications

Model	Output kW	Output Btu/h	Set Output kW	Flow Connection mm	Return Connection mm	Cold Water In (system kit) mm	Pressure Relief mm	Weight (dry) kg
VTXOM15/26	15 - 26	50 - 90,000	21	22	22	15	15	143
VTXOM26/46	26 - 46	90 - 157,000	41	28	28	15	15	162
VTXOM46/70	46 - 70	157 - 240,000	64	1 1/4" BSP	1 1/4" BSP	N/A	N/A	288

Dimensions (mm)

Vortex Pro External
15-26kW & 26-46kW

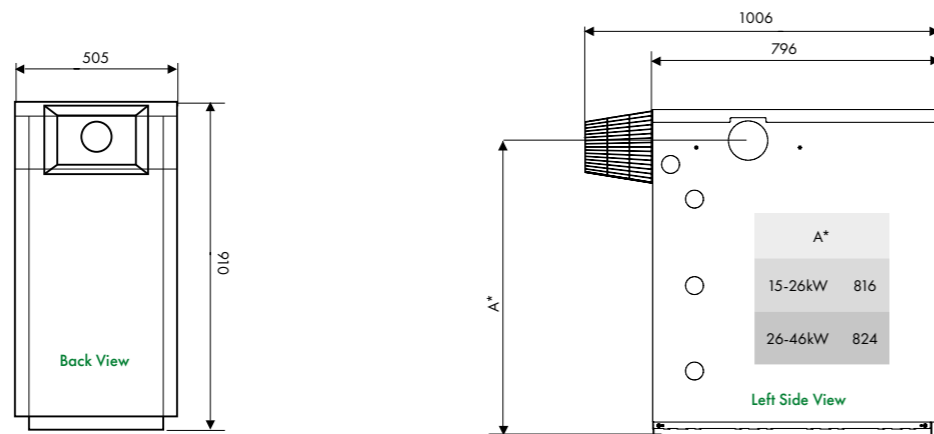

Vortex Pro External
46-70kW

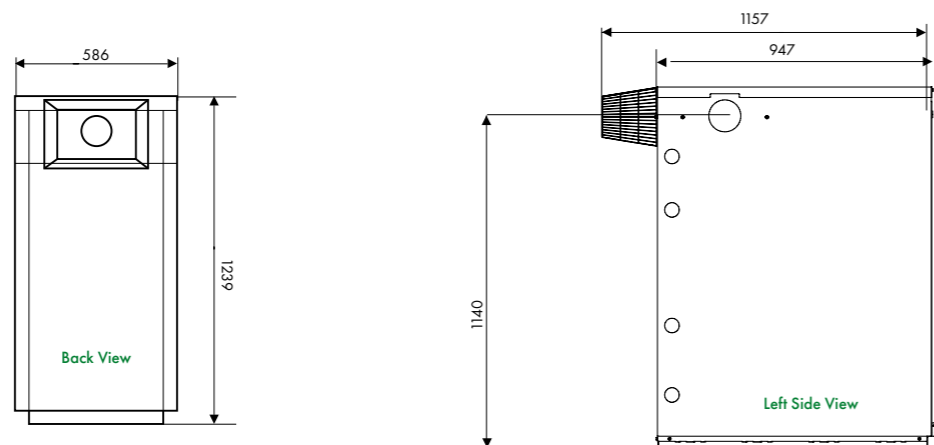

Vortex Pro Combi Range Technical Specifications

Model	Output kW	Output Btu/h	Set Output kW	Flow Connection mm	Return Connection mm	Cold Water In mm	Pressure Relief mm	Weight (dry) kg	Typical Hot Water Performance* L/min	Approx recovery time** min
VTXCOMBI21	21	70,000	21	22	22	15	15	160	12	4
VTXXSCOMBI26	26	90,000	26	22	22	15	15	163	15	4
VTXCOMBI26	26	90,000	26	22	22	15	15	177	15	4
VTXCOMBI36	36	123,000	36	28	28	22	15	200	20	3
VTXOMCOMBI21	21	70,000	21	22	22	15	15	181	12	4
VTXOMCOMBI26	26	90,000	26	22	22	15	15	206	15	4
VTXOMCOMBI36	36	123,000	36	28	28	22	15	225	20	3

*Hot water flow rate is dependent on mains pressure available. Figures are based upon an incoming mains water temperature of 10°C ** Based upon 100 litre draw off.

Dimensions (mm)

Vortex Pro Combi XS 26kW

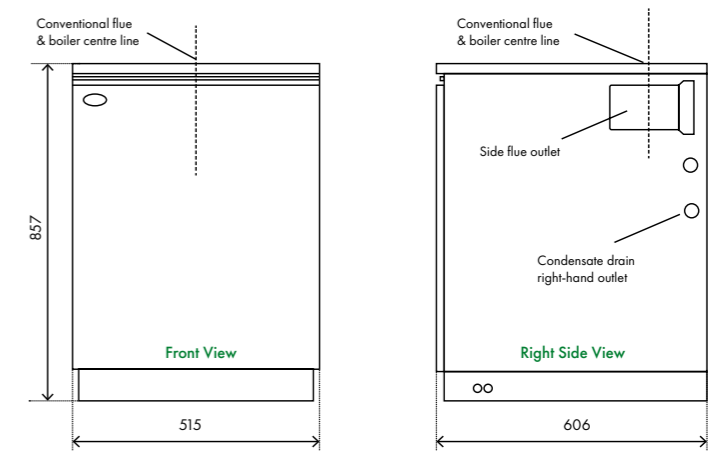

Vortex Pro Combi
21kW, 26kW, 36kW

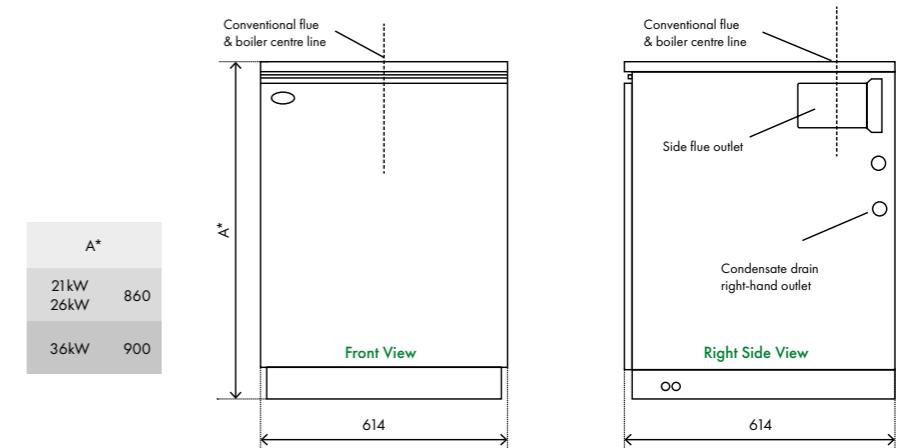

Vortex Pro Combi External
21kW, 26kW, 36kW

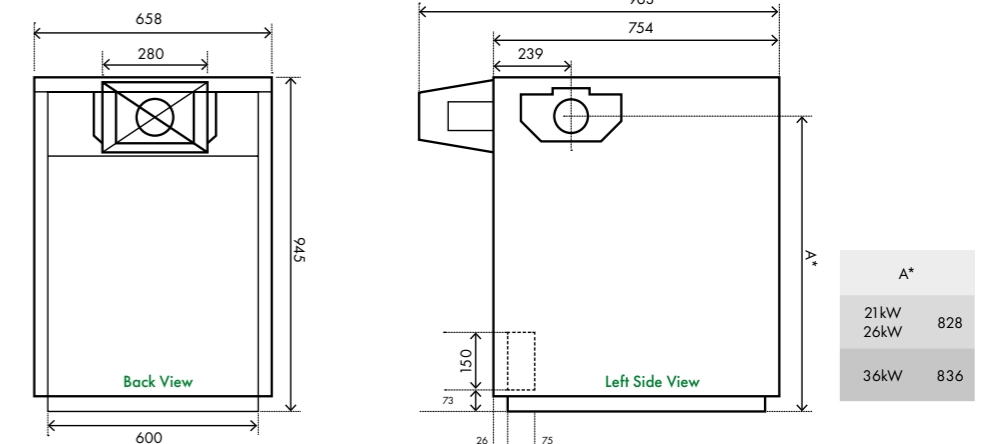

Vortex Boiler House Range Technical Specifications

Model	Output kW	Output Btu/h	Set Output kW	Flow Connection mm	Return Connection mm	Cold Water In mm	Pressure Relief mm	Weight (dry) kg
VTXBH1526	15-26	50 - 90,000	21	1" BSP	1" BSP	n/a	n/a	125
VTXBH2646	26-46	90 - 157,000	41	28mm	1" BSP	n/a	n/a	145
VTXBH4670	46-70	157 - 240,000	64	1¼" BSP	1¼" BSP	n/a	n/a	301

Dimensions (mm)

Vortex Boiler House 15-26kW

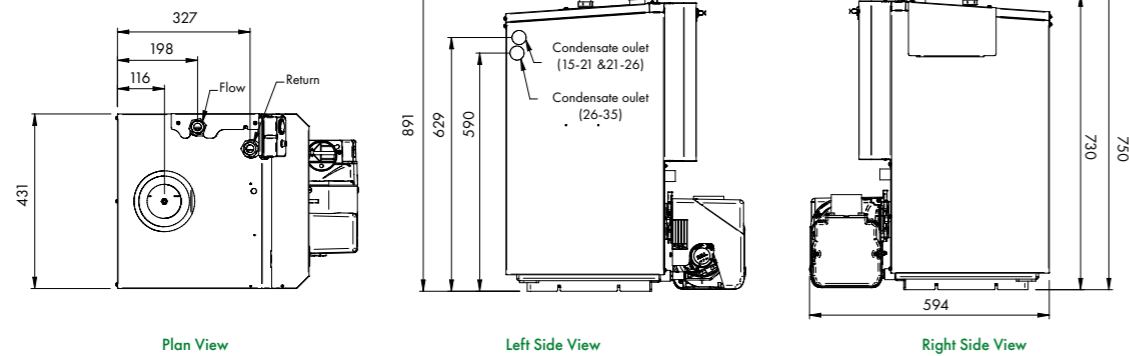

Vortex Boiler House 26-46kW

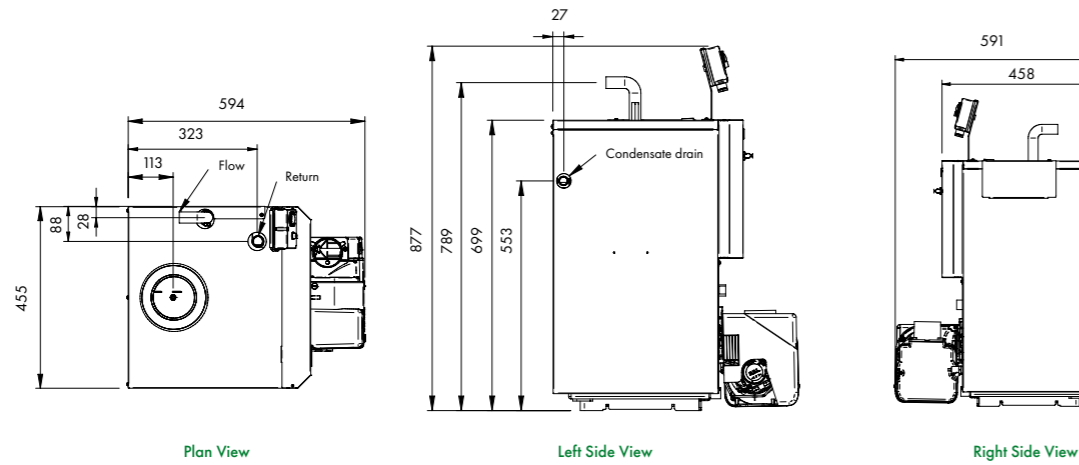

Vortex Boiler House 46-70kW

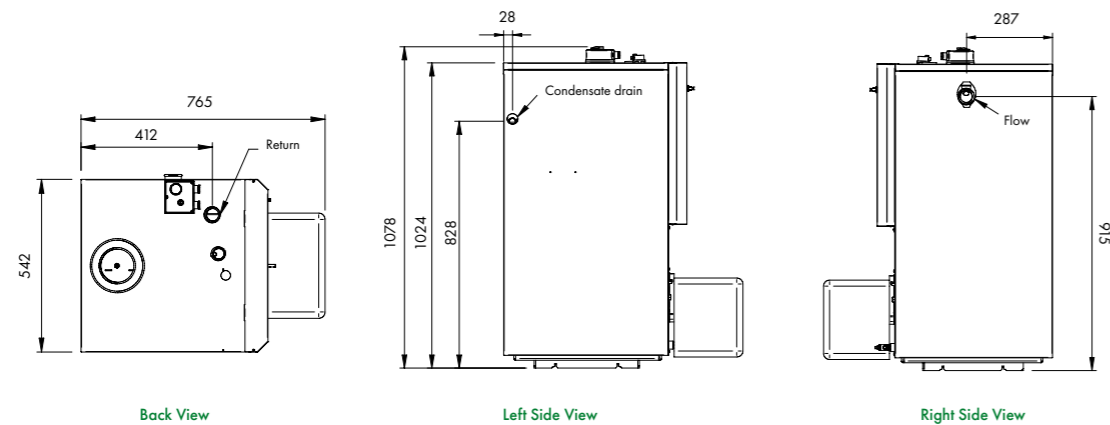

Mag One Central Heating Filter

The Mag One is the perfect solution to prevent breakdowns caused by both magnetic and non-ferrous particulate in the central heating system.

Using a simple to install, triple action filtration design, the Mag One filters magnetite and nonferrous debris from central heating systems with a 12,000 gauss neodymium magnet. The unit is also compatible with all system inhibitors and glycol solutions.

One Mag One filter provides innovative protection for up to 36kW. For larger systems you can fit two Mag One filters in a parallel circuit.

Models

VM01/x Mag One Central Heating Magnetic Filter 22-28mm

VM04 Mag One Fill and Flush Connector Kit

- Simple to install, easy to clean and drain
- 12000 gauss neodymium magnet
- 28mm chrome isolation valves with 22mm reducers
- 360° installation



VM04 fill and flush connector kit



A woman with blonde hair, wearing a light blue top, is shown in profile, adjusting a white thermostat on a wall. The background shows a modern kitchen and dining area with wooden furniture. A green text box is overlaid on the right side of the image.

Energy Management Range

Heating controls can affect system performance and efficiency. The correct control system not only makes it easier to maintain a more comfortable temperature within the home, but it keeps heating bills and CO₂ emissions down by using less fuel.

Grant has a range of individual control solutions that cleverly work together to enable the heating system to operate at optimal efficiency, ensuring householders get the best out of their system. These include weather compensation, sequence controllers, zone pumps and distribution headers. The systems are suitable for individual dwellings, properties with several zones, installations with multiple heat sources or a combination of different technologies.

Weather compensation

Heating systems should be designed to provide the required comfort condition inside the property when the outside temperature is at its lowest. However, this level of heating will not be required for every day of the heating season as the outside temperature will vary and only be at the lowest level for a relatively small number of days per year.

As the heat demand for a building is inversely proportional to the difference between the indoor and outdoor temperatures, the higher the outdoor temperature the lower the amount of heat required from the heating system. With the heat output of the heating system being determined by the water temperature within it, the system water will be at its hottest when the outside temperature is at its lowest.

Weather compensation controls the temperature of the water in the system such that it delivers the required amount of heat for the prevailing outside temperature, giving a better system efficiency.

Systems with weather compensation

Boiler flow and return temperatures will be monitored and controlled and the system can react promptly to internal and external air temperature changes.



Autumn

- Room thermostat calls for heat on a cool autumn night
- A signal is sent for the control to turn the boiler on and warm the house
- Control uses the outdoor temperature to calculate the water temperature to give required system output
- Control operates the boiler and the mixing valve to achieve the required water temperature (using less fuel)



Winter

- Room thermostat calls for heat on a cold winter day/night
- A signal is sent from the control to turn the boiler on and warm the house
- Control uses the outdoor temperature to calculate the water temperature required. This will be higher in colder weather
- Control operates the boiler to maximum and modulates the heating system to the desired temperature



GEO360 Weather Compensator

The Grant GEO360 weather compensation control system constantly monitors the outside air temperature and determines the required system water temperature for the current conditions. It then determines whether or not the boiler or heat pump needs to start and automatically varies the heat output of the system by controlling the temperature of the system water. This is achieved by using a mixing valve to blend the hotter flow from the boiler or heat pump with the cooler return water from the heating system.

Models

GEO360/28

GEO360 with 28mm valves (Vortex models up to 36kW)

GEO360/35

GEO360 with 35mm valves (Vortex models from 36 to 70kW)

- Cost effective to install and run
- The unit monitors weather conditions throughout the year so that the correct flow and return temperatures are maintained, thereby enabling the boiler to operate efficiently.
- System reacts promptly to internal and external temperature changes making it easier to maintain a more comfortable temperature within the home and keeps heating bills and CO₂ emissions down by using less fuel.



Simple system incorporating a GEO360 weather compensator

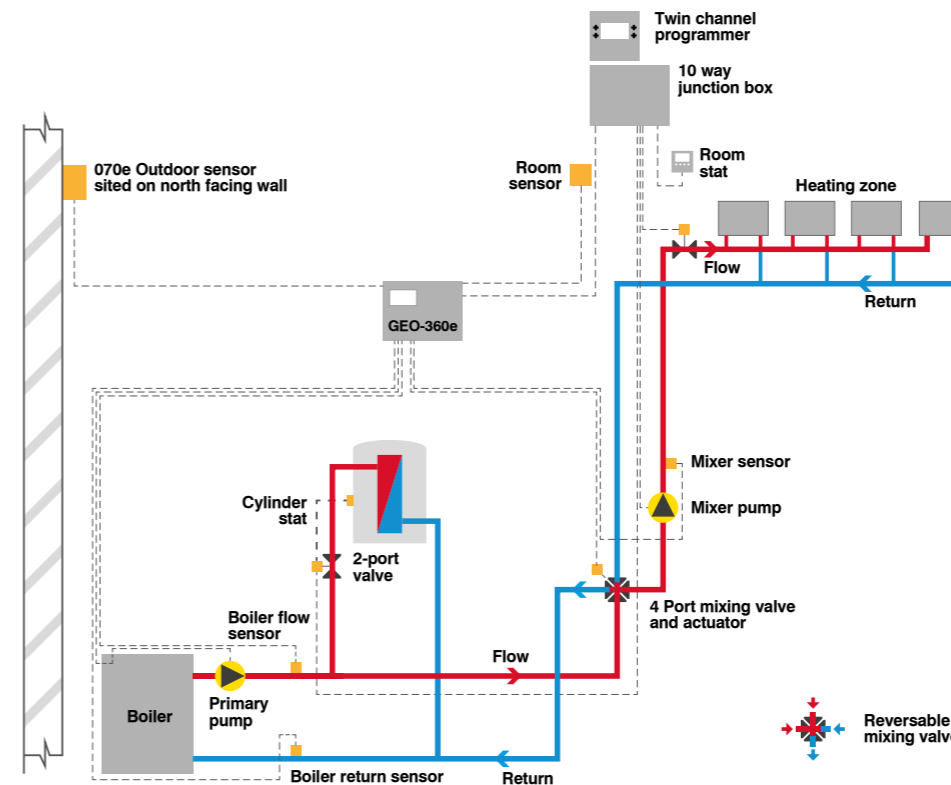

Concept drawing only - not site specific

GES264 Sequence Controller

The Grant 264 sequence controller is designed to manage from two to four heat sources. These may include renewable technologies such as air source heat pumps and wood pellet boilers or alternatively oil/gas boilers. The controller is able to cope with a mix of fuels all at the same time. This is achieved by using a common flow sensor and using the heat sources installed to satisfy the demand.

Models

GES264 sequence controller (for two to four heat sources)



The water temperature may be weather compensated and used with or without hot water priority, depending on the pipework layout, pumps and motorised valve set up.

When controlling up to 4 appliances the controller will record the time run for every heat source/boiler and rotate the firing sequence to provide an equal burn time for all units. This will ensure that all appliances share the load throughout the year. When firing takes place each unit will only run when required, depending on the load placed on the system. This ensures maximum efficiency and prevents unnecessary firing and wasted energy.

Depending on the system design and layout it is possible to include pump overrun. Primary and hot water pumps can also be controlled by the controller. When used in conjunction with a buffer/thermal store the weather compensation facility will be disabled as the store would be kept at a constant temperature. The control recognises this as a set point temperature and is preset at commissioning along with a check of all other parameters.

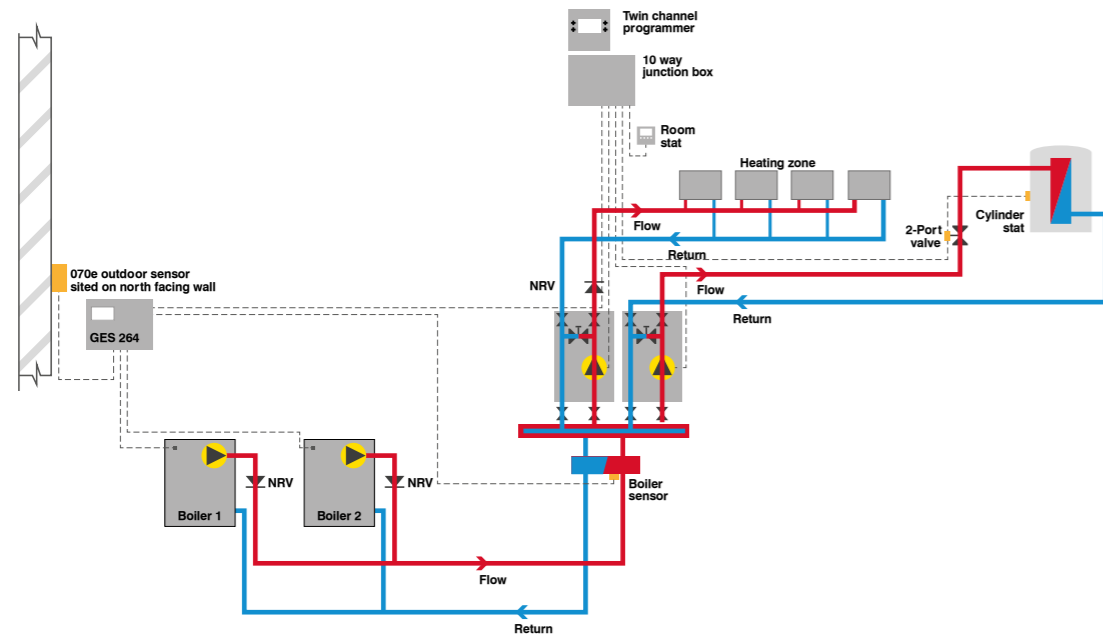

Concept drawing only - not site specific

Header Systems

Header systems are a cost effective way of installing multiple heat sources and feeding more than one heating zone which have different temperature requirements. This is achieved by using a small low loss header (known as a hydraulic switcher) and a distributor manifold.

Depending on the system load, two sizes are available (up to 70kW and up to 165kW @ Δt 20 °C flow and return set up temperature). The heating appliances are then connected to the switcher, which provides an open circuit for the appliance system water to feed the heating distribution header. This can be supplied with two to six Grant zone pump kits for each heating and hot water circuit, as required.

The Grant header system provides the installer and the customer with a professional installation which is both cost effective to install and run.

Technical Specification	70kW Header
Maximum flow rate	up to 3m ³ /h, 6bar
Distribution Header	110 x 110 x 508mm (min) - 1508mm (max) (depending on model)
Zone Pump Kit	1" male
Hydraulic switcher connection	1 1/4" male
Side connection	3/4" female

Technical Specification	165kW Header
Maximum flow rate	up to 7m ³ /h, 6bar
Distribution header	152 x 152 x 625mm (min) - 1625 (max) (depending on model)
Pump unit connection	1 1/4" male
Hydraulic switcher connection	2" male
Side connection	2" male



Components

Component	Description
GHS70/1252	1" flow and return distributor (2 zone)
GHS70/1253	1" flow and return distributor (3 zone)
GHS70/1254	1" flow and return distributor (4 zone)
GHS70/1255	1" flow and return distributor (5 zone)
GHS70/1256	1" flow and return distributor (6 zone)
GHS60/125	1 1/4" hydraulic switcher
GHS/WF100	Header bracket set wrap over 100mm
GHS/WF150	Header bracket set wrap over 150mm
GHS/WFHV	Header bracket set 90°
GHS05629	1 1/4" connector (quantity: 1) please note: 2 connectors per switcher required
GHS/0266M	1" isolation valve (quantity: 1) please note: 2 valves per pump station required
GHS/SG50*	Safety set up to 50kW (3 bar PRV) please note: if 70kW use GHS/SG200

Component	Description
GHS80/1252	1 1/4" flow and return distributor (2 zone)
GHS80/1253	1 1/4" flow and return distributor (3 zone)
GHS80/1254	1 1/4" flow and return distributor (4 zone)
GHS80/1255	1 1/4" flow and return distributor (5 zone)
GHS80/1256	1 1/4" flow and return distributor (6 zone)
GHS80/570	2" vertical hydraulic switcher
GHS/WF160	Header bracket set wrap over 160mm
GHS/WFHV160	Header wall fixing set - 160mm
GHS076929	2" connection kit
GHS/55AMMS	1 1/4" isolation valve (quantity: 1) please note: 2 valves per pump station required
GHS/HT07	2" nut & gasket for 1 1/4" isolation valves (quantity: 1) please note: 2 sets of nut & gaskets per pump station required
GHS/SG200	Safety set up to 200kW (3 bar PRV)

*** IMPORTANT**
GHS/SG50 can only be used with the 70kW system if the system output is less than 50kW. If the system output is between 50kW and 70kW then GHS/SG200 should be used

Zone Pump Kits

Zone pump kits are available in two sizes, each with both constant temperature and variable temperature options. A variable temperature option (including a mixing valve and actuator) is used where weather compensation, using a Grant GEO360, is required.

The kits are designed to sit vertically on the header unit with a fully insulated compact black cover which houses the high efficiency circulating pump and valves. The flow and return valves are colour coded to show flow and return with large handles incorporating a thermostat dial, giving a clear indication of the flow or return temperature.

The variable temperature pump kit has a mixing valve which is adjusted by an actuator to mix the flow temperature to the heating circuit. The actuator and valve respond to the GEO360 weather compensator to give the correct comfort level to the property. A non return valve is also supplied to prevent reverse circulation.

Constant temperature pump kit



Variable temperature pump kit



Components

GHS/CT01	Constant temperature / variable speed 6 metre zone pump kit
GHS/CT02	Constant temperature / variable speed 8 metre zone pump kit
GHS/VT03	Variable temperature / variable speed 6 metre zone pump kit
GHS/VT04	Variable temperature / variable speed 8 metre zone pump kit
GHS/CT05	32mm constant temperature / variable speed 7 metre zone pump kit
GHS/CT06	32mm constant temperature / variable speed 8 metre zone pump kit
GHS/VT07	32mm variable temperature / variable speed 7 metre zone pump kit
GHS/VT08	32mm variable temperature / variable speed 8 metre zone pump kit



Zone Pump Kit - Constant Temperature

Comprises	Zone pump, isolator ball valves, temperature gauges and non-return valve
Connections	1" (70kW header) and 1 1/4" (165kW header)
Dimensions	H250 x W390 x D190 mm
Maximum temperature	110 °C
Application	35kW max @ ΔT = 20K 1500l/h
High efficiency pump	6m, 8m - 70kW 7m, 8m - 165kW

Zone Pump Kit - Variable Temperature

Comprises	Mixing valve and actuator
Connections	1" (70kW header) and 1 1/4" (165kW header)
Dimensions	H250 x W420 x D250 mm
Maximum temperature	110 °C
Application	35kW max @ ΔT = 20K 1500l/h
High efficiency pump	6m, 8m - 70kW 7m, 8m - 165kW

System incorporating 6x zones (70kW) low loss header system with 2x boilers

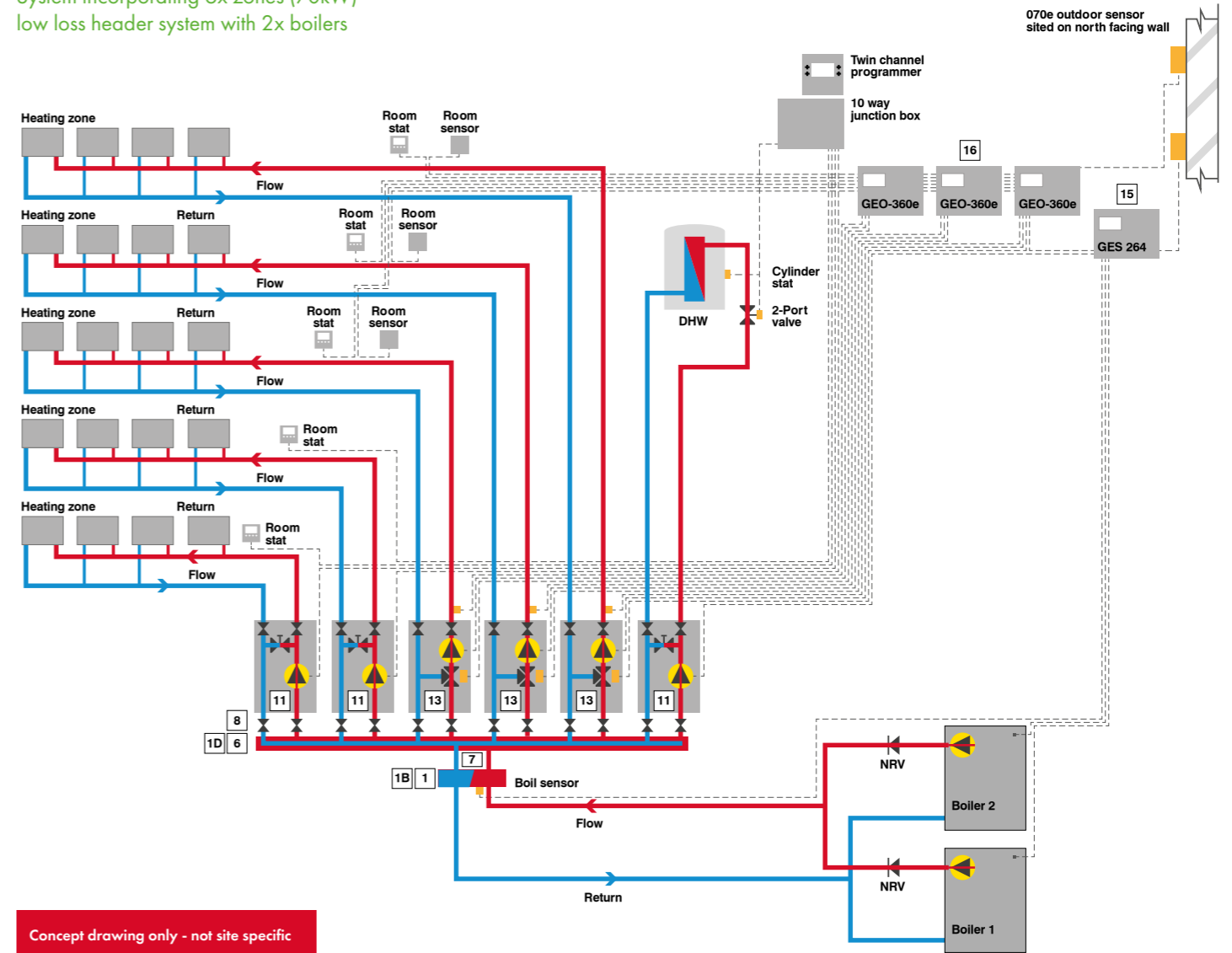

Concept drawing only - not site specific

Ref	Part description	Further information	Product code
1	1 1/4" Hydraulic switcher – 70kW	Note: 70kW @ 20KΔt	GHS60/125
1B	Header bracket set wrap over 100mm	Only 1 set per header required	GHS/WF100
1C	Header bracket set wrap over 150mm	Only 1 set per header required	GHS/WF150
1D	Header bracket set 90°	Only 1 set per header required	GHS/WFHV
2	1" F&R Distributor*	2-6 is the number of pump units (circuits) per installation as required by the installer (see drawings)	GHS70/1252
3	1" F&R Distributor*		GHS70/1253
4	1" F&R Distributor*		GHS70/1254
5	1" F&R Distributor*		GHS70/1255
6	1" F&R Distributor		GHS70/1256
7	1 1/4" connector (1 qty)		2 connectors per switcher
8	1" valves (1 qty)	2 valves per zone pump kit	GHS/0266M
11	Constant temperature 6m zone pump kit	Constant temp, variable speed for heating hot water primary circuits	GHS/CT01
12	Constant temperature 8m zone pump kit*	Constant temp, variable speed for heating hot water primary circuits	GHS/CT02
13	Variable temperature 6m zone pump kit	For heating circuits only. With mixing valve used with GEO360 w/comp	GHS/VT03
14	Variable temperature 8m zone pump kit*	For heating circuits only. With mixing valve used with GEO360 w/comp	GHS/VT04
15	GES264 sequence controller	Up to 4 boiler sequence controller & weather compensation	GES264
16	GEO360	Weather compensator	GHS/GEO360

* Note: component not shown on illustration

Alternative use of energy management controls

This layout shows a system incorporating a ThermoWave thermal store, linking a number of different technologies such as an oil boiler, two air source heat pumps, a solar thermal system, a GES264 sequence controller and a GEO360 weather compensator.

System with thermal store incorporating a number of heat sources

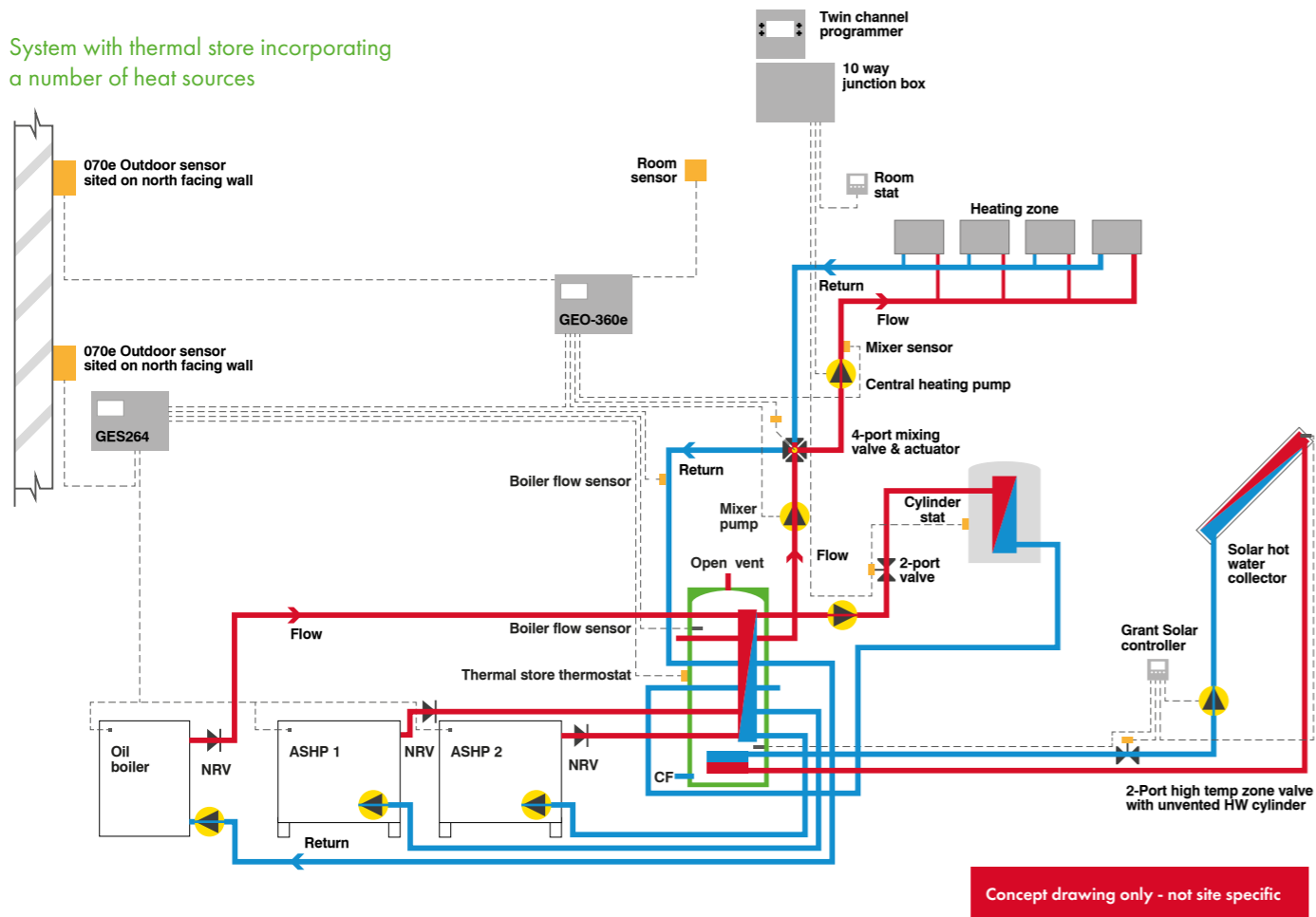

ErP package uplift

In addition to increasing the overall efficiency of the heating system, by incorporating a GES264 controller or GEO360 optimiser, you will also benefit from an increase in efficiency under the Energy Related Products Directive (ErP) by up to 4%.

For example, a heating system using a Vortex Pro 15-26kW, a Sahara two panel solar kit and a 300lt QR cylinder would have a package rating of A. Incorporate a GEO360 and the package rating will increase to A+.



QR Cylinders

The Quick Recovery (QR) cylinder range comprises of high efficiency indirect hot water solutions which are designed to partner with heating technologies such as oil and gas boilers, air source heat pumps and solar thermal. Each model can complement both traditional and renewable systems, providing an eco-friendly, reliable and energy efficient solution for a home's hot water requirements. All of the QR cylinder models are WRAS approved, can be used as unvented or open vented cylinders, and are designed to suit multiple installation scenarios, making them Grant's most versatile range of hot water cylinders.



- Factory-fitted 3kW immersion heater
- Fast recovery stainless steel coils
- Labelled tappings and connections
- Factory fitted temperature and pressure relief valve
- Supplied with unvented kit as standard including expansion vessel, inlet manifold, tundish, 2-port motorised valve and dual thermostat

Discover the range at grantuk.com

FIND OUT MORE



*Subject to full T&C's

Aftercare Support

Grant UK not only supply efficient products but they also provide comprehensive aftercare support for customers. From in-house Technical and Customer Support Teams through to their extensive online resources, Grant UK strives to help their customers throughout the lifetime of their product.

Grant UK's Home Heating Blog shares useful tips and articles for homeowners and heating professionals, featuring advice and information about their products. For example, to help homeowners look after their Grant boiler, there is a blog which shares five handy tips and energy efficiency measures for boilers which should help their appliance work as effectively as possible.



READ MORE

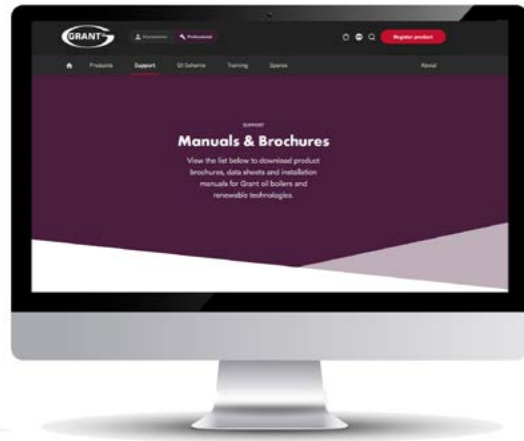
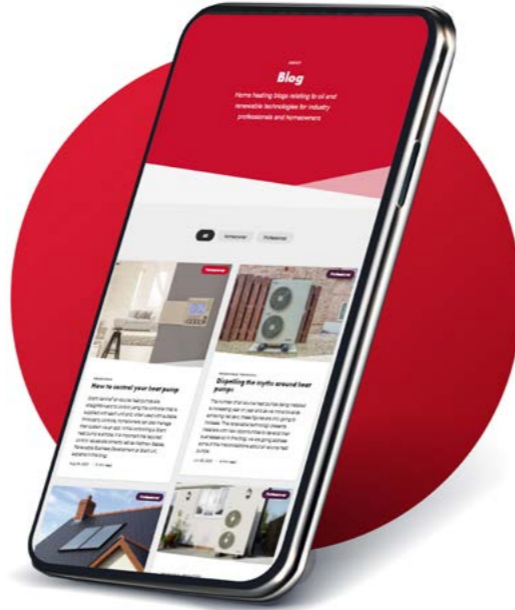

The user and installation manuals for all the Vortex oil boiler models are available to download from Grant UK's website so if the original manual, supplied with the product, is misplaced, end-users can easily access a copy of their boiler's user instructions by visiting grantuk.com/support/manuals-brochures.



DOWNLOADS

The Grant Team is also on hand to help either via email or over the phone. To get in touch, simply visit grantuk.com/support.



Guarantees

Grant's products have been designed and built to last for years. Installers and homeowners who choose the Grant brand can be assured by the reliability, quality and value of each product. To reflect the confidence that the Company has in all of their appliances, standard and extended guarantees are available throughout the ranges.

Quality guaranteed as standard

Grant UK guarantees the manufacture of their products for a period of twelve months from the date of installation as standard, provided that the product has been installed in full accordance with the installation and servicing manual supplied. **This guarantee will be extended to a total period of two years if the product is registered with Grant UK within thirty days of installation and serviced at twelve monthly intervals.** Please be advised that in cases when the installation is completed more than six months from the date of purchase, the guarantee period will commence six months from the date of purchase.

Extended guarantees through the G1 Installer Network

The standard two year guarantee on Grant's oil boilers can be increased if the product is installed by one of Grant UK's G1 Installers. G1 Installers can offer extended guarantees on the Grant products that they install and register. The G1 extended product guarantees are subject to the product being installed in full accordance with both the installation and servicing instructions as well as the G1 Scheme Terms and Conditions. Please note, G1 extended guarantees are only activated when the G1 Installer registers the appliance via their G1 Portal or Click App.



Grant UK's G1 Scheme provides installers with the essential tools that they need to successfully fit and endorse Grant products, which in turn gives members confidence in the products they install. Homeowners who choose a G1 engineer can be confident that their Grant product is installed to the highest possible standards while also enjoying the peace of mind that comes with the extended guarantees that G1 installers can activate on their installations.

Homeowners looking to find a G1 Installer in their local area should visit Grant UK's website and use the Find an Engineer online search grantuk.com/support/find-an-engineer.

Extended Warranty Packages

When a Grant boiler is not installed by a G1 Installer, homeowners can still increase the warranty on their appliance. Grant UK offer a range of three year extended warranty options which are available for oil boilers registered within thirty days of installation. These are designed to give homeowners added peace of mind after the standard two year product guarantee has expired. To read more about the extended product warranties available to purchase from Grant UK, please visit grantuk.com/support/extended-warranties.

FIND AN
ENGINEER



EXTENDED
WARRANTIES

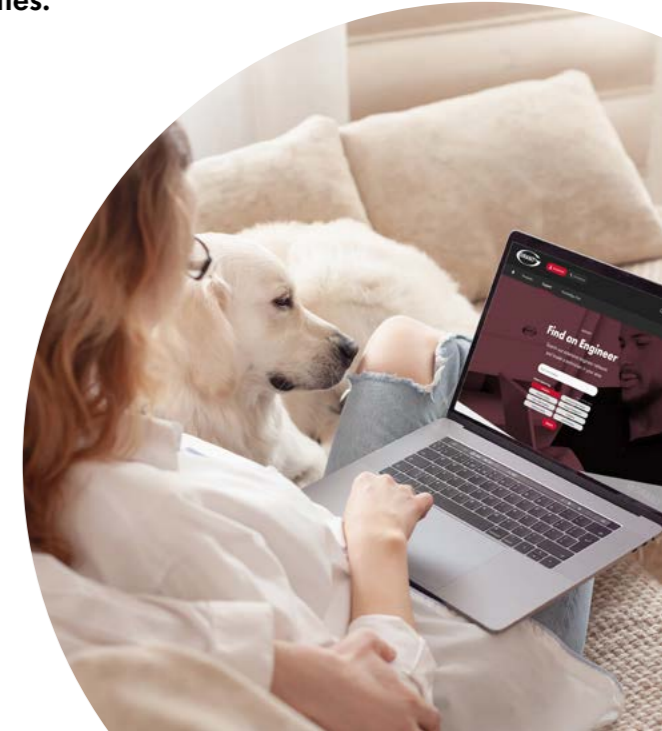

EZ-Fit Flues

The Grant EZ-Fit flue systems suit all Vortex oil-fired boilers. The EZ-Fit flues are stainless steel and are available as low level, high level and vertical kits which are suitable for internal and external boiler installations. Unique flexi liner packs can also be supplied which enable condensing boilers to utilise an existing chimney. With an extensive range of kits and accessories, Grant's EZ-Fit flues provide installers with choice and flexibility to suit multiple installation scenarios.



Clearances

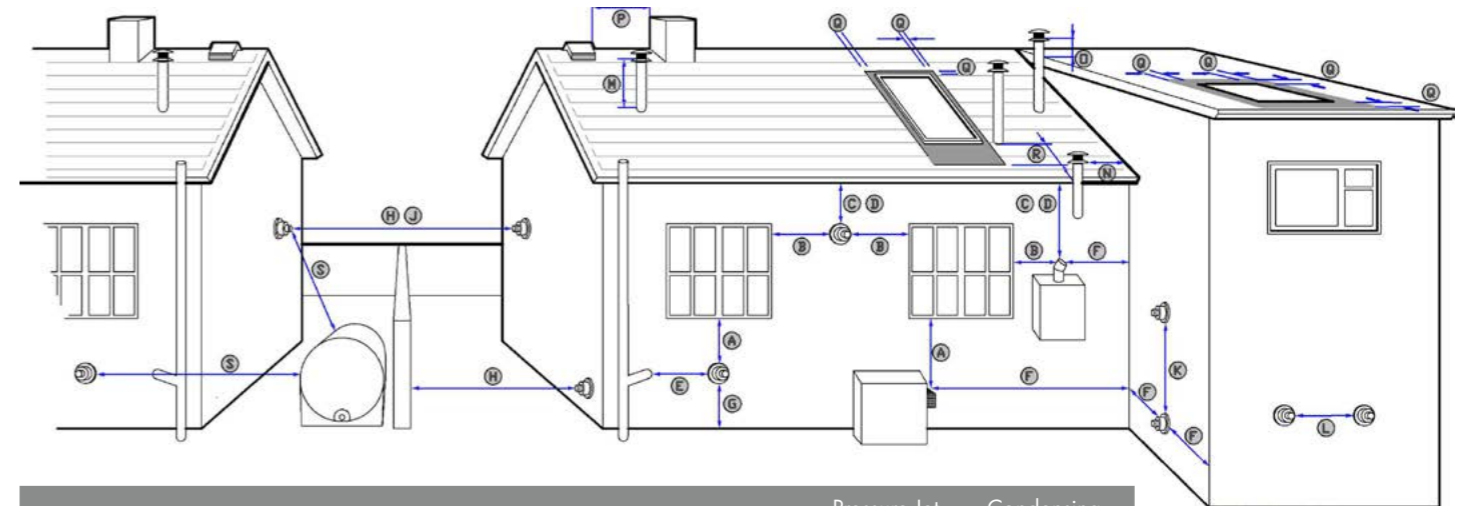

Ref	Location of outlet	Pressure Jet (mm)	Condensing (mm)
A	Directly below an opening, air brick opening, opening window, etc.	600	1000**
B	Horizontally to an opening, air brick opening, opening window, etc.	600	1000**
C	Below a gutter, eaves or balcony with protection	75*	1000**
D	Below a gutter, eaves or balcony without protection	600	1000**
E	From vertical sanitary pipe work	300	
F	From an internal or external corner	300	
G	Above ground or balcony level	300	
H	From a surface or boundary facing the terminal	600	2500**
J	From a terminal facing the terminal	1200	
K	Vertically from a terminal on the same wall	1500	
L	Horizontally from a terminal on the same wall	750	
M	Above the highest point of an intersection with the roof	600	
N	From a vertical structure to the side of the terminal	750	
O	Above a vertical structure less than 750 mm from the side of the terminal	600	
P	From a ridge terminal to a vertical structure on the roof	1500	
Q	Above or to the side of any opening on a flat or sloping roof	300	
R	Below any opening on a sloping roof	1000	
S	From oil storage tank (Class 1)	1800***	

Note:

* A heat shield at least 750mm wide must be fitted to provide protection of combustible material

** Clearances required by BS 5410-1:2014 to alleviate the effect of plume nuisance. If a risk assessment shows that there will be no impact from pluming, then the 'pressure jet' figure could apply - seek confirmation from Local Authority Building Control.

*** Seek guidance from OFTEC Book 3 (Oil Storage and Supply).

Individually designed conventional flue systems for modular boiler installations.

Grant UK offers a unique customised design service, where two or more boilers are connected in a modular form to a single conventional flue stack. This service includes the design and supply of flue headers and flue systems for condensing boiler installations and is available to merchants upon completion of a simple site survey form. Contact our technical department on: +44 (0) 1380 736920 for further details.

1. Appliances burning class D fuel have additional restrictions. Refer to BS 5410-1:2014.
2. Vertical structure in N, O and P includes tank or lift rooms, parapets, dormers, etc.
3. Terminating positions A to L are only permitted for appliances that have been approved for low level flue discharge when tested in accordance with BS EN 303-1, OFS A100 or OFS A101.
4. Terminating positions should be at least 1.8 metres from an oil storage tank (Class 1) unless a wall with at least 30 minutes fire resistance and extending 300 mm higher and wider than the tank is provided between the tank and the terminating position.
5. Where a flue is terminated less than 600 mm away from a projection above it and the projection consists of plastics or has a combustible or painted surface, then a heat shield of at least 750 mm wide should be fitted to protect these surfaces.
6. If the lowest part of the terminal is less than 2 metres above the ground, balcony, flat roof or other place to which any person has access, the terminal should be protected by a guard.
7. Notwithstanding the dimensions given above, a terminal should not be sited closer than 300 mm to combustible material. In the case of a thatched roof, double this separation distance should be provided. It is also advisable to treat the thatch with a fire retardant material and close wire in the immediate vicinity of the flue.
8. A flue or chimney should not pass through the roof within the shaded area delineated by dimensions Q and R.
9. Where protection is provided for plastics components, such as guttering, this should be to the standard specified by the manufacturer of the plastics components.
10. Terminals must not be sited under car ports.
11. Terminals at low levels (terminals under 2.1 metres) have more restrictive recommendations and should not be positioned near public foot ways, frequently used access routes, car parking spaces less than 2.5 metres from the terminal or patio's (hard surface area).
12. Further guidance can be obtained from BS 5410-1:2014, OFTEC Book 4 (Installation) and Approved Document J.
13. Grant UK flue products are fully compliant with the CE (Communauté Européenne/European Community) standards having undergone rigorous product testing.

Yellow System Low Level Balanced EZ-Fit flue kits

The Grant low level balanced flue range has been developed to make the installation of Grant Vortex boilers both quick and simple, whilst ensuring trouble free operation even in the most exposed site conditions.

Reduces installation time

The round low level kits feature self-sealing ducts requiring no silicone or tape for joints, and the unique quick-fit connection arrangement ensures a perfect seal every time. In fact, the telescopic flue system requires only two simple operations to complete the installation. The kits are compatible with all Grant boilers, except external modules.

The Grant flue terminal

The flue terminal has a compact design and is available in a black painted finish, making it ideal for installations where the visual appearance is important. The design reduces the possibility of condensate, produced in the combustion process, staining external wall surfaces or patio slabs.

Low Level balanced flue hole cutting dimensions				
Model	Dimensions (mm)			
	A dia	B	C	D
Vortex Pro 15-26	127	115	768	n/a
Vortex Eco 15-21 & 21-26	127	115	768	n/a
Vortex Pro 26-46	162	115	780	n/a
Vortex Eco 26-35	162	115	780	n/a
Vortex Pro 46-70	162	112	1105	n/a
Vortex Pro Combi 21 & 26	127	115	768	n/a
Vortex Pro Combi 36	162	105	780	n/a
Vortex Eco Wall Hung 16-21	127	112	H + 765*	220
Vortex Boiler House 15-26	127	120	768	n/a
Vortex Boiler House 26-46	162	120	780	n/a
Vortex Boiler House 46-70	162	120	1102	n/a

Note: *H is the height (mm) from floor to underside of boiler casing.

Note: Flue diameters 123mm 152mm

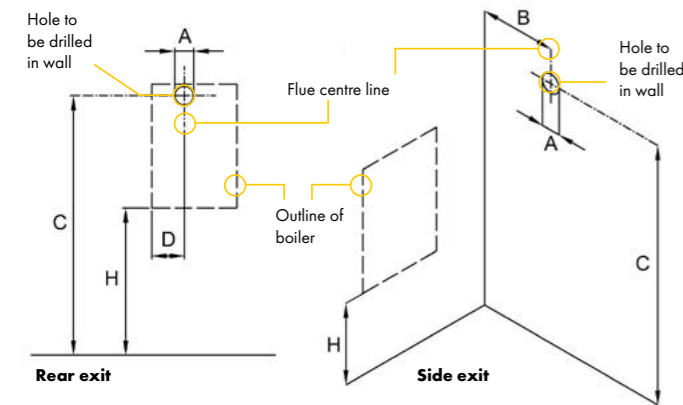

Note: Dimension 'B' is given with the boiler pushed back against the rear wall. Any clearances must be added to 'B'. Dimension 'A' includes an extra 10mm over the size of the terminal to provide clearance for fitting.

Extensions

The flue kits are telescopic and available in short or standard options. For wall thicknesses greater than shown, three extensions are available which extend the flue by 225mm, 450mm or 675mm to a maximum of four metres. 90° and 45° elbows are also available to give a greater degree of flexibility when siting the boiler.

Plume diverter kits (Black painted)

Grant has developed a solution for existing low level flues where plumbing causes a nuisance. The new plume diverter kits are designed to fit with our latest EZ-Fit Yellow low level balanced flue system. The kit comprises a starter elbow, which fits over the already fitted flue terminal, 2 x 1m lengths of stainless steel flue pipe, a terminal elbow together with 2 x adjustable brackets. It is available in 80mm diameter for boilers up to 26kW and 100mm diameter for boilers from 26-70kW.

Low Level flue kit

with 90° elbow extension added (black painted terminal section)

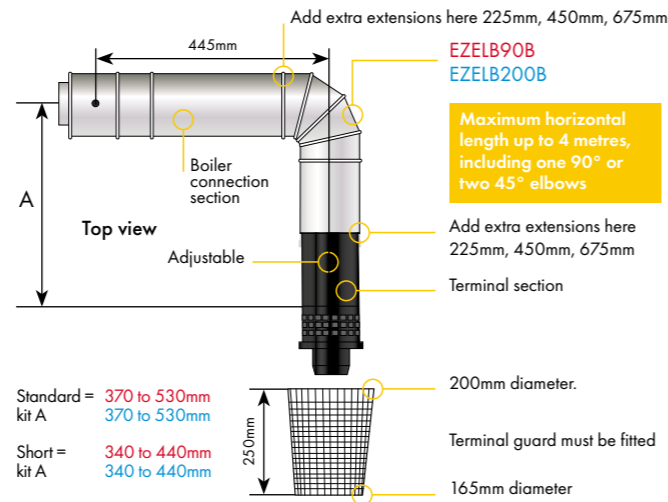

Standard = 370 to 530mm
kit A = 370 to 530mm
Short = 340 to 440mm
kit A = 340 to 440mm

Low Level flue kit

(black painted terminal section)

Standard flue kit (black): EZ90B / EZ200B
Short flue kit (black): EZ90SB / EZ200SB

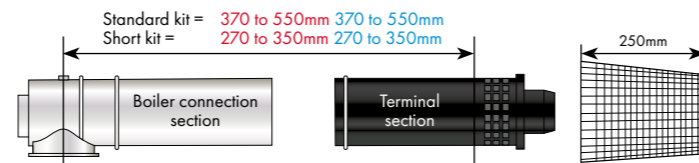

Contents of Low Level flue kit:

- Boiler connector section
- Terminal section
- Flue guard
- Dress plate (not shown)
- Plugs and screws
- Side outlet cover trim (not shown)
- Lubricant (not shown)
- Snorkel clamp (not shown)

Low Level balanced flue kits

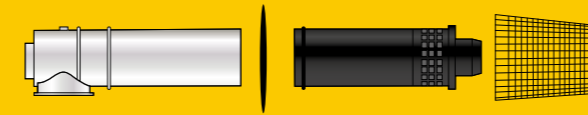

Standard flue kit (Black Painted Finish)	
EZ90B	Models up to 26kW
EZ200B	Models over 26kW

Short flue kit (Black Painted Finish)	
EZ90SB	Models up to 26kW
EZ200SB	Models over 26kW

Low Level balanced flue extensions

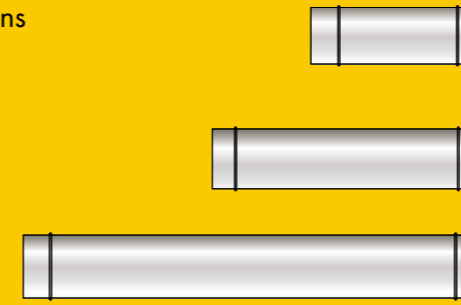

Extension 225mm	
X90S	Models up to 26kW
X200S	Models over 26kW

Extension 450mm	
X90M	Models up to 26kW
X200M	Models over 26kW

Extension 675mm	
X90L	Models up to 26kW
X200L	Models over 26kW

Important
Flue extensions cannot be cut. Yellow system extensions are for horizontal use only and cannot be used vertically with Green, Orange, Red or White system components.

Low Level balanced flue accessories

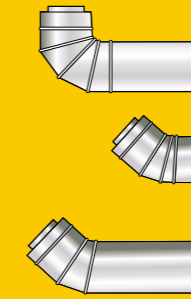

90° elbow kit	
EZELB90	Models up to 26kW
EZELB200	Models over 26kW

45° elbow only	
EZ45/90S	Models up to 26kW
EZ45/200S	Models over 26kW

45° elbow kit	
EZ45/90	Models up to 26kW
EZ45/200	Models over 26kW

Important
Horizontal lengths up to 4 metres can be accommodated, including one 90° or two 45° elbows.

Offset elbows

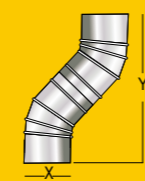

45° elbows can be used with Low Level kits to offset the flue. Extensions can be used between elbows.

Elbows directly connected

Code	X	Y
EZ45/90S	120	260
EZ45/200S	130	280

Important
Extended elbows allow telescopic adjustment for extensions or terminal sections.

Plume diverter kits and accessories



2m Plume diverter kit	
GPDA90B	Models up to 26kW
GPDA200B	Models over 26kW

Extension 250mm	
GPD250EXT/90B	Models up to 26kW
GPD250EXT/200B	Models over 26kW

Extension 500mm	
GPD500EXT/90B	Models up to 26kW
GPD500EXT/200B	Models over 26kW

Extension 1000mm	
GPD1000EXT/90B	Models up to 26kW
GPD1000EXT/200B	Models over 26kW

Important
Maximum height for a plume diverter kit is 6 metres. Deduct 500mm for each 45° elbow used.

45° elbow	
GPDA45/90B	Models up to 26kW
GPDA45/200B	Models over 26kW

Wall bracket	
GPDBRKT90B	Models up to 26kW
GPDBRKT200B	Models over 26kW

White System High Level Balanced EZ-Fit flue kits
High level balanced flue kits feature the same boiler connections as the low level flue. The unique connection system on the high level flue ensures easy assembly thereby reducing installation costs.

Flexible design

The kits may be extended horizontally and vertically. It is now possible to create offsets in standard high level flue systems by using our 45° elbows and extension kits – increasing the versatility of this range.

Maximum flue length

High Level balanced flues can be extended to **a maximum of 10 metres overall**, using the extension kits illustrated on page 5. Deduct one metre for each additional 45° elbow used (maximum 6 elbows).

High level balanced flue hole cutting dimensions						
Model	Dimensions (mm)					
	A dia	B	C min	D min	D max	E
Vortex Pro 15-26	175	115	1225	1740	2130	n-a
Vortex Eco 15-21 & 21-26	175	115	1225	1740	2130	n-a
Vortex Pro 26-46	200	115	1275	1710	2010	n-a
Vortex Eco 26-35	200	115	1275	1710	2010	n-a
Vortex Pro 46-70	200	112	1600	2035	2335	n-a
Vortex Pro Combi 21 & 26	175	115	1225	1740	2130	n-a
Vortex Pro Combi 36	200	115	1275	1710	2010	n-a
Vortex Eco Wall Hung 16-21	200	112	H+1217*	H+1732*	H+2122*	220
Vortex Boiler House 15-26	175	200	1215	1715	2115	n-a
Vortex Boiler House 26-46	200	200	1280	1700	2020	n-a
Vortex Boiler House 46-70	200	200	1595	2015	2335	n-a

Note: *H is the height (mm) from floor to underside of boiler casing.

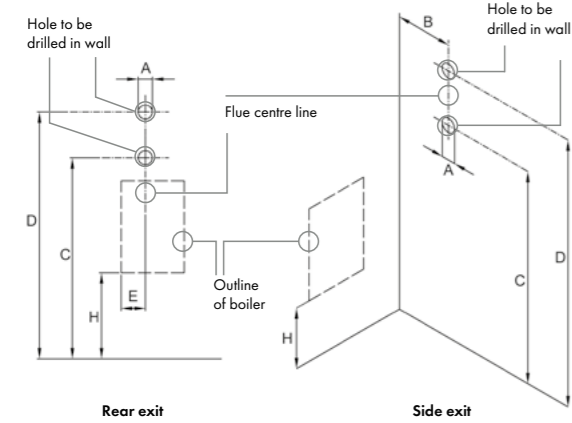

Note: Flue pipe diameter: 150mm 180mm excluding locking bands (see dimension 'A' opposite for hole size).

Dimensions

Section 'B' is the starter piece for the flue system and fits into the boiler connector supplied with the kit. Section 'B' incorporates the air supply spigot and a combustion test point. Sections 'C' and 'D' combine to form a telescopic length. Terminal section 'F' slides over elbow 'E'. The horizontal length can be extended using the extensions listed. The adjustable extension cannot be connected to the terminal section 'F' – a fixed extension must be used. The vertical height can be extended using the extensions or 45° elbows listed. For short heights sections 'C' and 'D' may be omitted and elbow 'E' fitted to starter section 'B'.

Top casing height = X	
Model	Dimensions (mm)
Vortex Pro 15-26	170
Vortex Eco 15-21 & 21-26	170
Vortex Pro 26-46	205
Vortex Eco 26-35	205
Vortex Pro 46-70	225
Vortex Pro Combi 21 & 26	170
Vortex Pro Combi 36	205
Vortex Eco Wall Hung 16-21	165

Internal High Level flue kit (white powder coated)

HL K01 50/90
HL K02 90/200

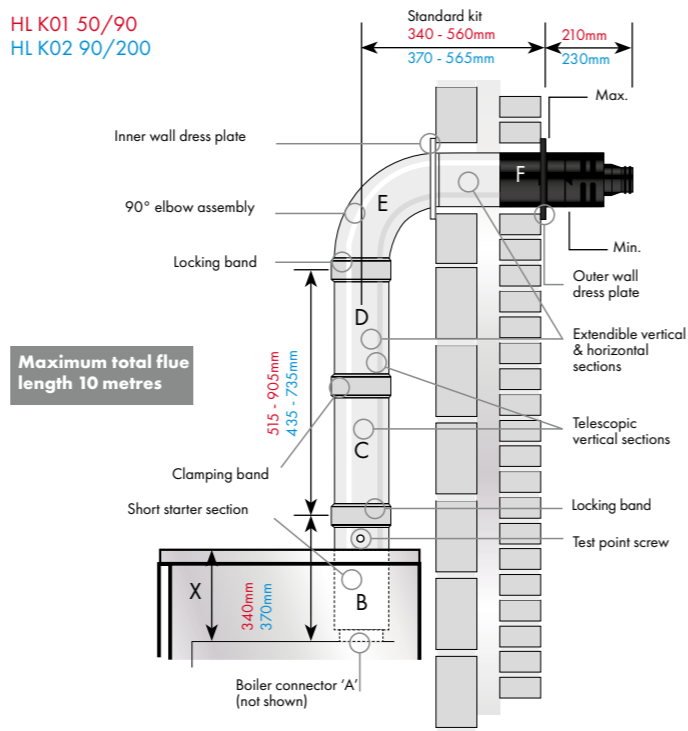

Maximum total flue length 10 metres

Contents of High Level balanced flue kit:

- Boiler connector A
- Short starter section B
- Vertical telescopic section C/D
- Horizontal telescopic section (inc. terminal) E/F
- Locking bands
- Inner seals (red)
- Outer seal (black)
- Boiler connector
- Dress plates (inner & outer)
- Fitting Instructions

Note: For height adjustment see chart on the left.

Internal High Level balanced flue kits

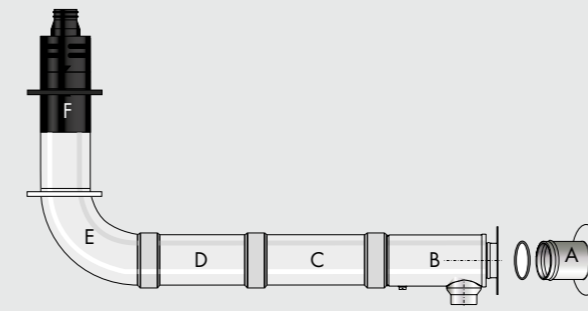

1.2 metre High Level flue kit	
HL K01 50/90	Models up to 26kW
HL K02 90/200	Models over 26kW

Important

If the terminal section executes below two metres, a terminal guard must be fitted. A terminal guard is required when the flue terminates less than 2 metres above outside ground level (not supplied as standard).

Internal High Level balanced flue kits

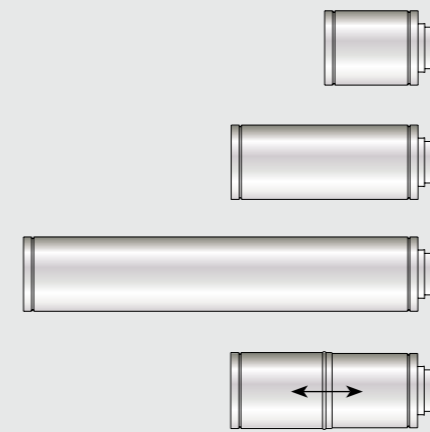

Extension 225mm C/W locking band	
EXT K31 225/90	Models up to 26kW
EXT K32 225/200	Models over 26kW
Extension 450mm C/W locking band	
EXT K09 450/90	Models up to 26kW
EXT K10 450/200	Models over 26kW
Extension 950mm C/W locking band	
EXT K11 950/90	Models up to 26kW
EXT K12 950/200	Models over 26kW
Adjustable extension 275-450mm C/W locking band	
EXT K13 ADJ/90	Models up to 26kW
EXT K14 ADJ/200	Models over 26kW

Important

Flue extensions cannot be cut. White system extensions are for High Level, Vertical and Red system Internal use only and cannot be used with Yellow, Green or Orange system components.

Important

We recommend an additional wall bracket for every 1 metre of flue extension.

High Level balanced flue accessories

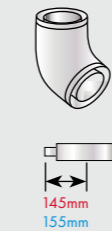

45° Elbow C/W locking band	
ELB K21 45/90	Models up to 26kW
ELB K22 45/200	Models over 26kW
Wall bracket	
BRK 29 90	Models up to 26kW
BRK 30 200	Models over 26kW

Important

High Level balanced flues can be extended to a maximum length of 10 metres using the extension kits illustrated above. Deduct one metre for each additional 45° elbow used (maximum 6 elbows). We recommend an additional wall bracket for every 1 metre of flue extension.

Offset elbows

45° elbows can be used with High Level kits to offset the flue. Extensions can be used between elbows.

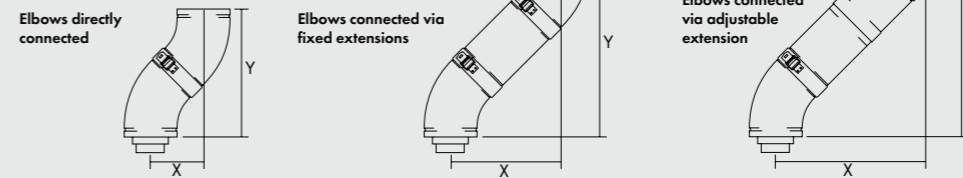

Code	X	Y
ELB K21	140	340
ELB K22	160	385

Code	Extension	X	Y
ELB K21	EXT225	300	500
	EXT450	455	665
	EXT950	810	1010
ELB K22	EXT225	320	545
	EXT450	475	700
	EXT950	830	1055

Code	X	Y
ELB K21	335-455	535-655
ELB K22	355-475	580-700

Important

A terminal guard is required when the flue terminates less than 2 metres above outside ground level (not supplied as standard).

*Internal High Level balanced flue systems are compatible with all Grant boilers, with the exception of the external modules.

White System Vertical Balanced EZ-Fit flue kits

Vertical balanced flue kits share the same boiler connections as our high level kits. The unique connection system on the vertical balanced flue ensures easy assembly thereby reducing installation costs.

Flexible design

As with our high level kits it is now possible to create offsets in straight flue runs by using our 45° elbows and adjustable extension kits – increasing the versatility of this range.

Maximum Vertical flue length

Vertical balanced flues can be extended to a maximum length of 12 metres in a straight run using the extension kits illustrated on page 7. Deduct one metre for each additional 45° elbow used (maximum 6 elbows).

Dimensions

The dimensions shown are measured from the top of the boiler spigot, not the boiler case. The distance between the boiler flue spigot and the top of the casing should be taken into consideration (See boiler installation manual).

Section (A) is the starter piece for the flue system and push fits into the boiler connector supplied with the kit. Section (B) incorporates the air supply spigot and a combustion test point.

Sections (C) and (D) combine to form a telescopic length. Fixed extension (E) fits onto telescopic section (D). Terminal section (F) fits onto fixed extension (E).

For short flue heights section (E) may be omitted and the terminal section (F) may be fitted directly to section (D). The terminal section (F) overlaps section (D) by 50mm.

Terminal extension

A new extended black terminal section for the vertical flue systems is now available, which extends the flue extract section by a further one metre (VTTEXT90 / VTTEXT200).

This kit is useful, if for instance, there is a roof window or opening too close to the terminal.

Vertical flue kit (white powder coated)

VT K05 50/90
VT K06 90/200

Note: Flue pipe diameter: 150mm 180mm Excluding locking bands

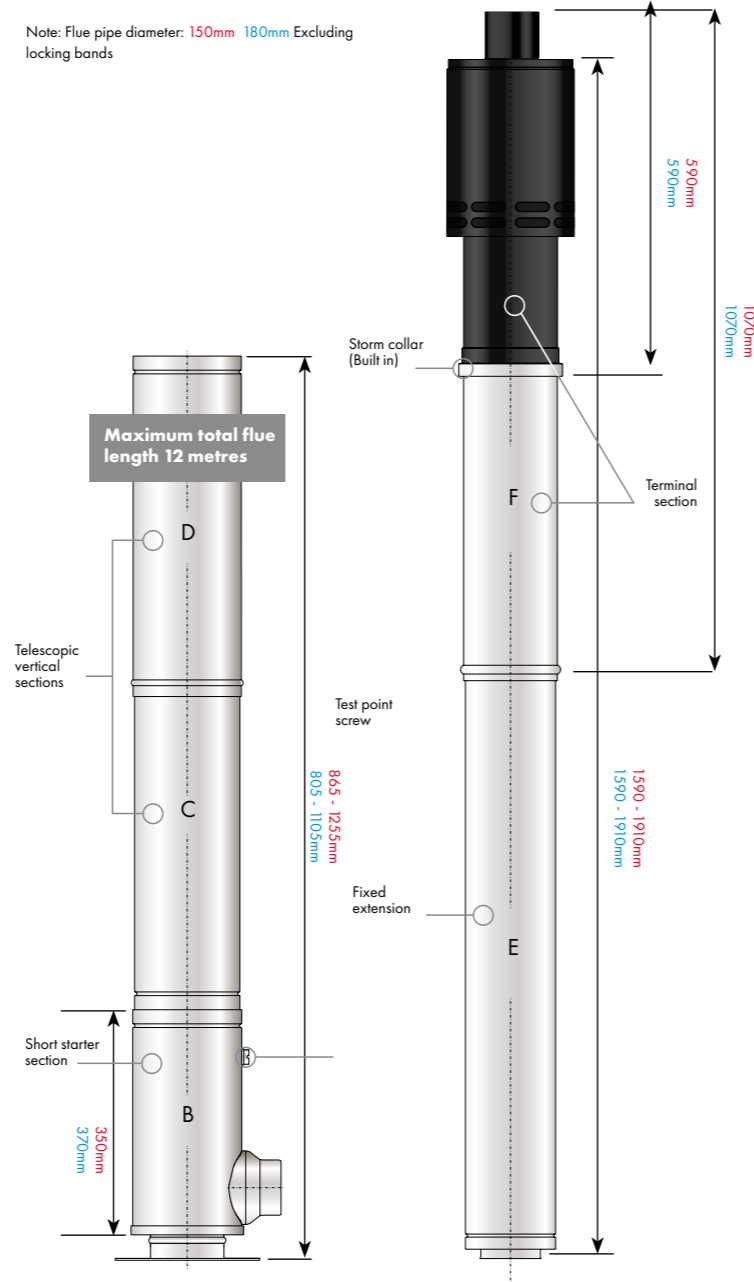

Quick fit connection

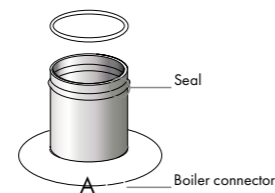

Contents of 3 metre balanced flue kit:

- Boiler connector A
- Short starter section B
- Telescopic vertical sections C/D
- Fixed section 950mm E
- Terminal section F (inc. storm collar)
- Locking bands (not shown)
- Inner seals (red)
- Ceiling dress plate (not shown)
- Firestop spacers (not shown)
- Wall bracket
- Fitting Instructions

Internal Vertical balanced flue kits

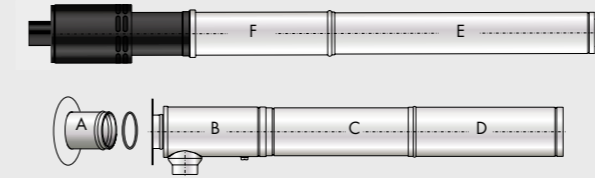

3 metre Vertical flue kit	
VT K05 50/90	Models up to 26kW
VT K06 90/200	Models over 26kW

Internal Vertical balanced flue extensions

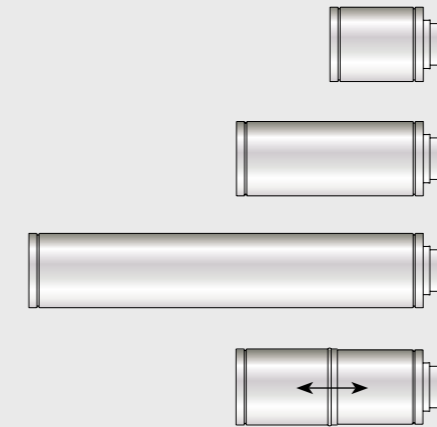

Extension 225mm c/w locking band	
EXT K31 225/90	Models up to 26kW
EXT K32 225/200	Models over 26kW

Extension 450mm c/w locking band	
EXT K09 450/90	Models up to 26kW
EXT K10 450/200	Models over 26kW

Extension 950mm c/w locking band	
EXT K11 950/90	Models up to 26kW
EXT K12 950/200	Models over 26kW

Adjustable extension 275-450mm c/w locking band	
EXT K13 ADJ/90	Models up to 26kW
EXT K14 ADJ/200	Models over 26kW

Important

Flue extensions cannot be cut. White system extensions are for High Level, Vertical and Red system Internal use only and cannot be used with Yellow, Green or Orange system components.

Important

We recommend an additional wall bracket for every 1 metre of flue extension.

Vertical balanced flue accessories

	45° Elbow c/w locking band	
	ELB K21 45/90	Models up to 26kW
	ELB K22 45/200	Models over 26kW
	Wall bracket (white powder coated)	
	BRK 29 90	Models up to 26kW
	BRK 30 200	Models over 26kW
	Flat roof flashing - aluminium	
	VT K27 F90	Models up to 26kW
	VT K28 F200	Models over 26kW
	Pitched roof flashing – aluminium	
	VT MF 90/200	All models

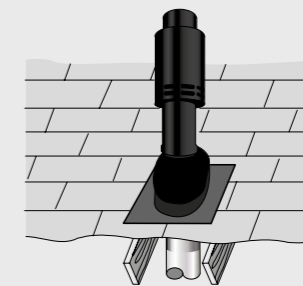

Pitched roof flashing – lead (with collar)	
VT K25 P90	Models up to 26kW
Pitched roof flashing – lead (no collar)	
VT K26 P240	Models over 26kW
Pitched roof flashing – lead replacement (with collar)	
VT K26 P200/X	Models over 26kW
Vertical terminal extension	
VTTEXT90	Models up to 26kW
VTTEXT200	Models over 26kW

Offset elbows

45° elbows can be used with High Level kits to offset the flue. Extensions can be used between elbows.

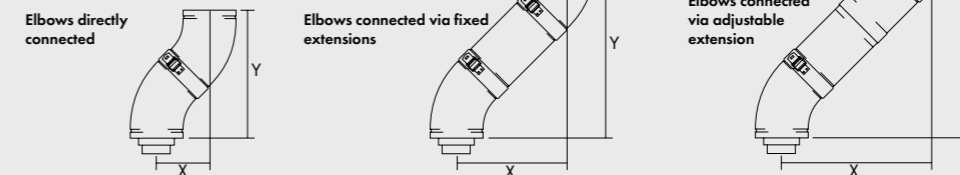

Code	X	Y
ELB K21	140	340
ELB K22	160	385

Code	Extension	X	Y
ELB K21	EXT225	300	500
	EXT450	455	665
	EXT950	810	1010
ELB K22	EXT225	320	545
	EXT450	475	700
	EXT950	830	1055

Code	X	Y
ELB K21	335-455	535-655
ELB K22	355-475	580-700

Red System Flexi Vertical balanced EZ-Fit flue kits

The Grant Red system is a unique flexible balanced flue solution to nuisance plumbing and cold draughts. It is designed for Grant Vortex condensing boilers up to 26kW (90,000Btu/h) and allows an existing masonry chimney to be utilised rather than re-site the boiler and pipework.

Red System kits

The Grant Red System is supplied in a pack consisting of two lengths of stainless steel flexible vertical flue pipe (available in lengths for 6, 8, 10 and 12 metres), a rigid/flex adaptor, telescopic flue (upper and lower), support clamp, locking band, starter section, boiler connector, fixings and screws and a tube of mastik.

Extensions and elbows (from White System)

The flexible vertical balanced flue kits share the same EZ-Fit flue extensions and elbows as the Grant White system. This unique quick fit connection arrangement ensures easy assembly thereby reducing installation costs.

The maximum vertical straight length of the flue, from the top of the boiler to the top of the terminal, is 20 metres – using no more than four 45° elbows.

One metre of straight flue length should be deducted for every elbow used. If the flexible liner has to pass around an offset inside the chimney, two metres of straight flue length should be deducted to compensate for this i.e. equivalent two 45° elbows.

Flue extensions cannot be cut, adjustable extensions should be used where required.

Offset elbows

45° elbows can be used with High Level kits to offset the flue. Extensions can be used between elbows.

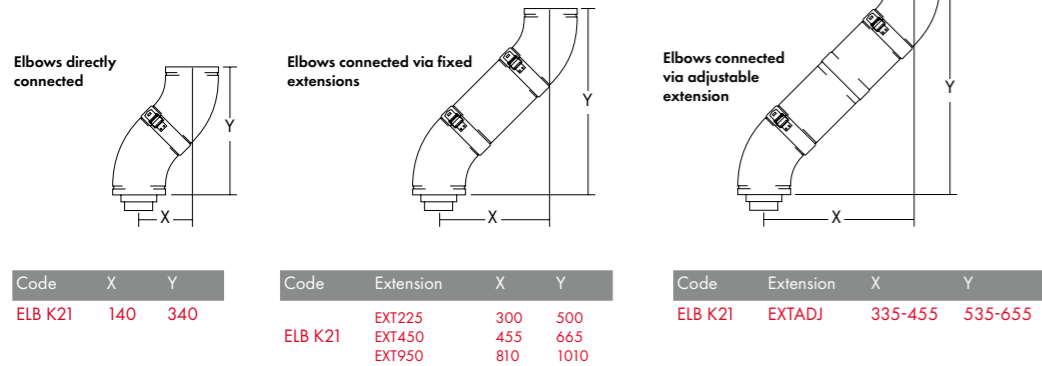

Maximum straight flue length from the boiler to the top of flue terminal = 20 metres.

Note: Flexi flue pipe diameter:
Inner diameter - 80mm
Outer diameter - 125mm

Important
The Red System shares extension pieces and elbows from the White system.

Optional extras (from White System)

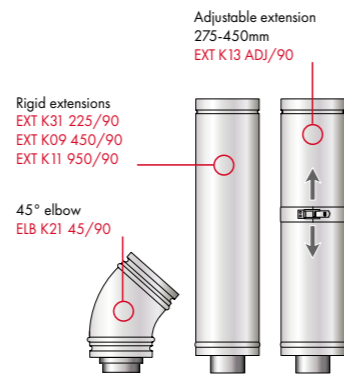

Rigid to flexible balanced flue

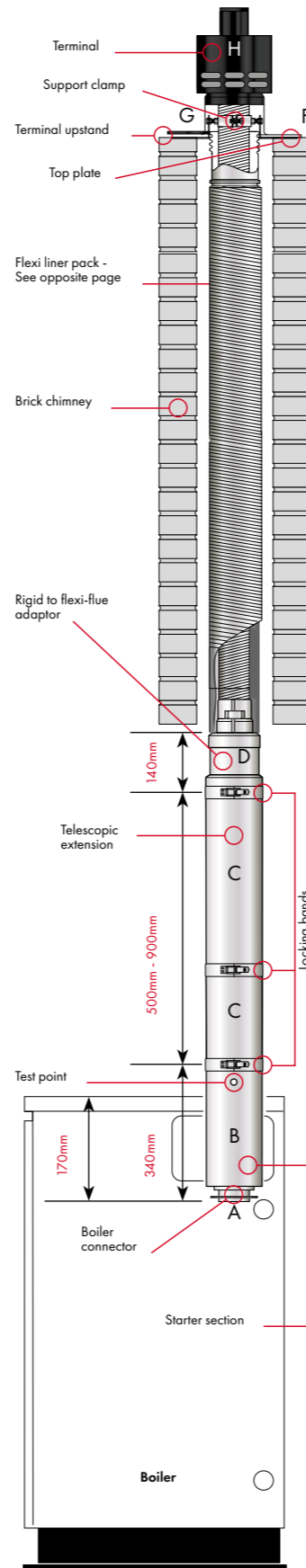

Flexi Vertical balanced flue pack with liner

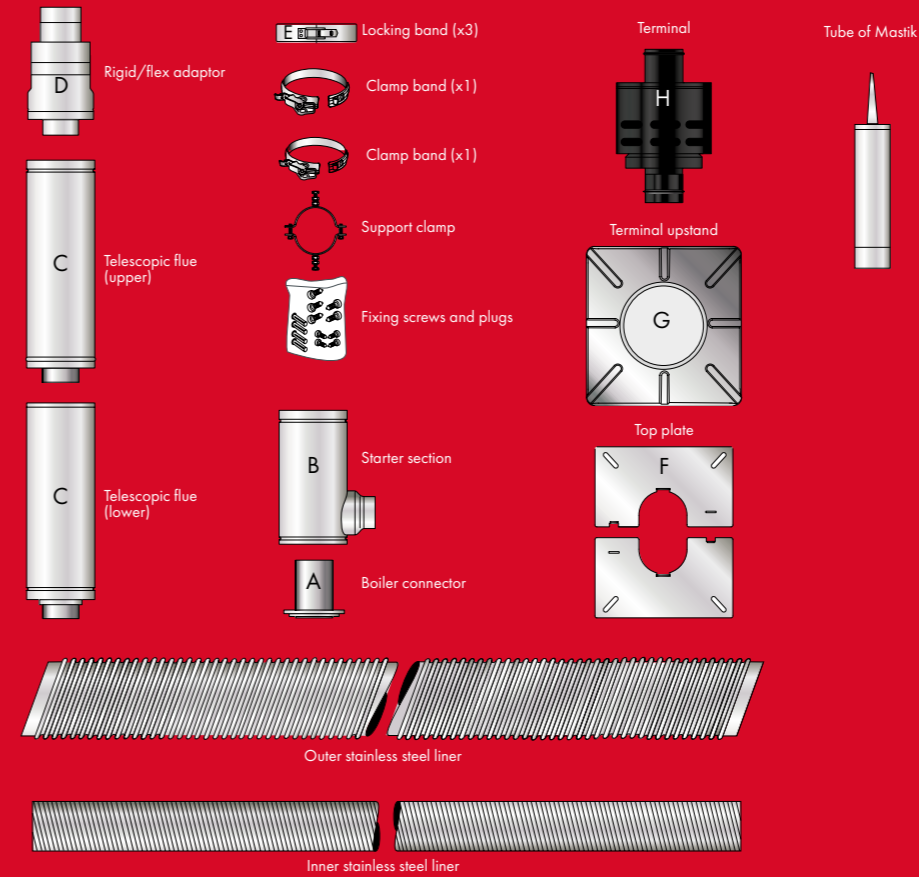

6 metre Flexible flue liner pack
GFX BF 6/26 COMR Models up to 26kW

8 metre Flexible flue liner pack
GFX BF 8/26 COMR Models up to 26kW

10 metre Flexible flue liner pack
GFX BF 10/26 COMR Models up to 26kW

12 metre Flexible flue liner pack
GFX BF 12/26 COMR Models up to 26kW

Note: Longer Flexi balanced flue liner kits are available by special order. Liners are directional and should be installed with the arrows facing upwards.

Rigid flue extensions & elbows (from White System)

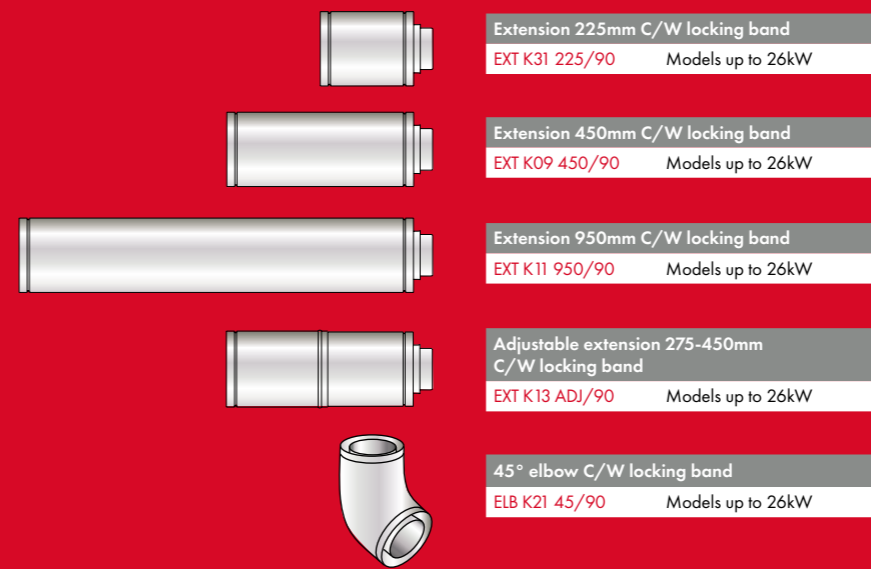

Important
Flue extensions cannot be cut. White system extensions are for High Level, Vertical and Red system Internal use only and cannot be used with Yellow, Green or Orange system components.

External High Level/Vertical flues - black painted

Green System External High Level/Vertical EZ-Fit flue kits

External high level and vertical flue systems are supplied in a modular form enabling most installations to be accommodated and are manufactured from high grade stainless steel.

Starter flue kits (Plume diverter)

The starter flue kit enables all internal boilers to be connected to an external high level or vertical flue system, whilst maintaining the room sealed operation of the boiler.

It is even possible to convert an existing EZ-Fit low level balanced flue kit to an external high level or vertical arrangement without any additional building work. This is particularly useful when plumbing from a low level flue terminal is a nuisance.

External high level flue hole cutting dimensions			
Model	Dimensions (mm)		
	A dia	B	C
Vortex Pro 15-26	127	115	768
Vortex Eco 15-21 & 21-26	127	115	768
Vortex Pro 26-46	162	115	780
Vortex Eco 26-35	162	115	780
Vortex Pro 46-70	162	112	1102
Vortex Pro Combi 21 & 26	127	115	768
Vortex Pro Combi 36	162	105	780
Vortex Eco Wall Hung 16-21	127	112	H + 765*
Vortex Pro Boiler House 26-46	162	115	780
Vortex Pro Boiler House 46-70	162	115	780

Note: *H is the height (mm) from floor to underside of boiler casing.

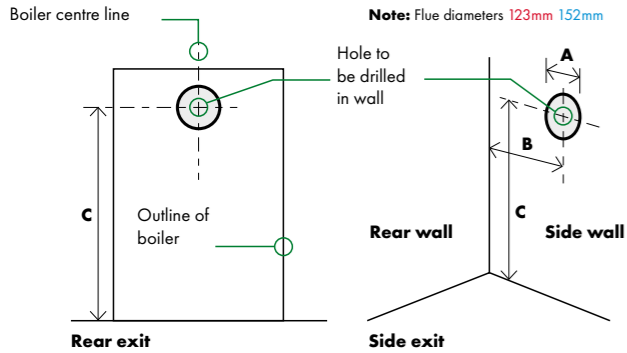

Note: Dimension 'B' is given with the boiler pushed back against the rear wall. Any clearances must be added to 'B'.

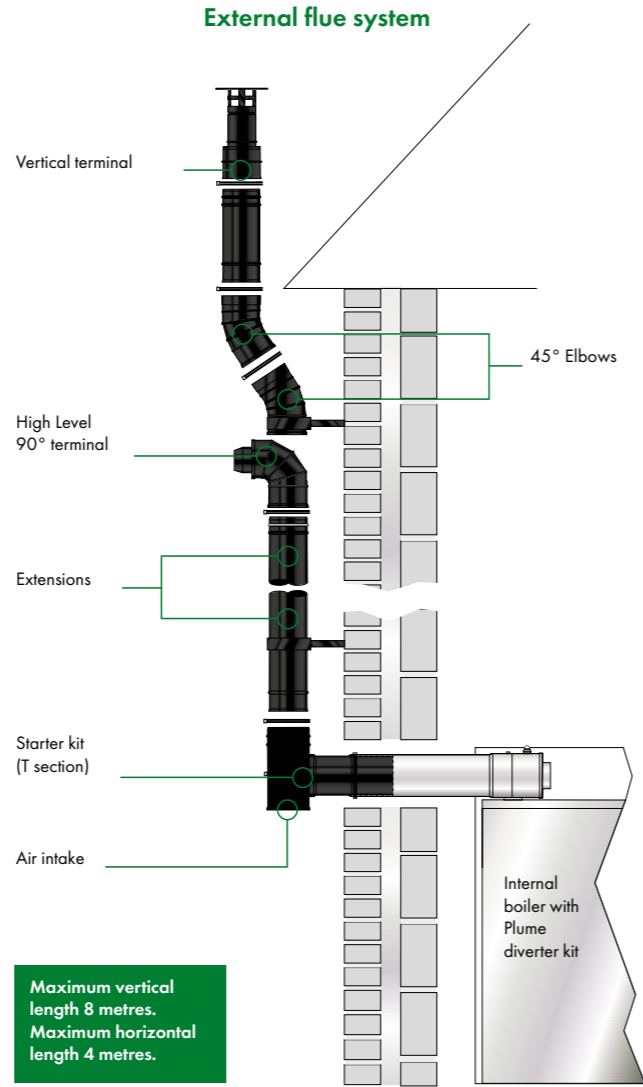

Offset elbows

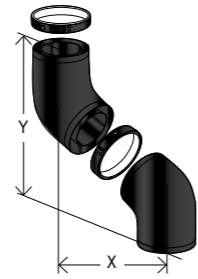

Code	X	Y
GE45/90B	126	304
GE45/200B	142	343

45° elbows can be used with high level flues to create off-sets. Extensions can be used between elbows.

Low Level starter kits

Standard kit = 370 to 550mm 370 to 550mm
Short kit = 270 to 350mm 270 to 350mm

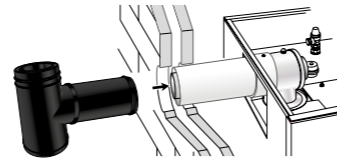

Contents of Low Level starter kit:

- Boiler connector section
- Tee section
- Side outlet cover trim
- Snorkel clamp (not shown)
- Dress plate
- Fixing clamp and gasket
- Lubricant (not shown)

Order part reference guide

External High Level/Vertical starter flue kit

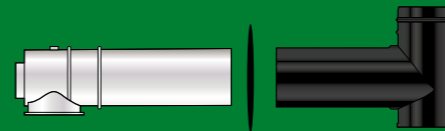

Standard flue kit	
GK90B	Models up to 26kW
GK200B	Models over 26kW
Short flue kit	
GK90SB	Models up to 26kW
GK200SB	Models over 26kW

Important

Starter flue kits can be extended horizontally using extensions or elbows from the Low Level balanced flue, Yellow system only. See page 3.



Extension 150mm c/w locking band	
GX150/90B	Models up to 26kW
GX150/200B	Models over 26kW



Extension 250mm c/w locking band	
GX250/90B	Models up to 26kW
GX250/200B	Models over 26kW



Extension 450mm c/w locking band	
GX450/90B	Models up to 26kW
GX450/200B	Models over 26kW



Extension 950mm c/w locking band	
GX950/90B	Models up to 26kW
GX950/200B	Models over 26kW



Adjustable extension 195-270mm c/w locking band	
GXA250/90B	Models up to 26kW
GXA250/200B	Models over 26kW

Important

Flue extensions cannot be cut. Green system extensions are for horizontal or vertical use with conventional flue systems only and cannot be used with Yellow or White balanced flue components.

Stainless steel terminals

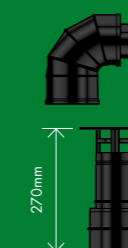

High Level 90° terminal	
GTH90B	Models up to 26kW
GTH200B	Models over 26kW

Important

Extension lengths given are effective lengths i.e. when fitted in a flue system.

Stainless steel

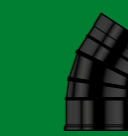

45° elbow c/w locking band	
GE45/90B	Models up to 26kW
GE45/200B	Models over 26kW



Extended wall bracket	
GEB90B	Models up to 26kW
GEB200B	Models over 26kW



Wall bracket	
GWB90B	Models up to 26kW
GWB200B	Models over 26kW

Orange System Conventional EZ-Fit flue kits

As many older oil fired boilers are traditionally connected to conventional flue systems, updating to a modern condensing boiler often results in the appliance needing to be relocated.

The Grant EZ-Fit conventional flue has been specifically designed for the Grant Vortex boiler range to enable the existing chimney to be re-used and the appliance retained in its original position.

Flexi packs

There are a range of EZ-Fit flexi packs containing all the components required to utilise the existing chimney, including a smooth bore stainless steel flue liner, terminal, clamp plate and connectors for both the flex and boiler. All that is required to complete the installation is extension pipes or elbows from our Grant Orange system accessories range.

Please note: the flexi liner should be installed with the directional arrows pointing upwards only.

Plumbing

Condensing boilers operate at extremely high efficiencies with cool flue gas temperatures, resulting in a plume of vapour being visible at the flue terminal. This plumbing (steam) is a normal condition of condensing boilers and indicates that the appliance is working efficiently. As an alternative to a Low Level, High Level, or Vertical balanced flue kit, utilising the original chimney with a Grant conventional Flexi-pack moves the plume of vapour above roof level.

Combustion air and ventilation

An adequate permanent air supply is required for the safe operation of all open-flued (**conventional flued**) oil-fired appliances. For new or replacement boilers in properties built prior to the latest change to the Building Regulations (pre Approved Document L1A 2006) in England and Wales this ventilation must be in accordance with BS5410-1:2014. For installations in properties built or refurbished under the above current Building Regulations, the first 5kW of output should no longer be omitted for the purposes of calculating the ventilation area required.

Rigid to Flexible Conventional flue system

Maximum vertical height from top of boiler to terminal 19 metres.

Important
For optional extensions and elbows - see page 13.

Important
Allow 600mm from top of boiler before first elbow.

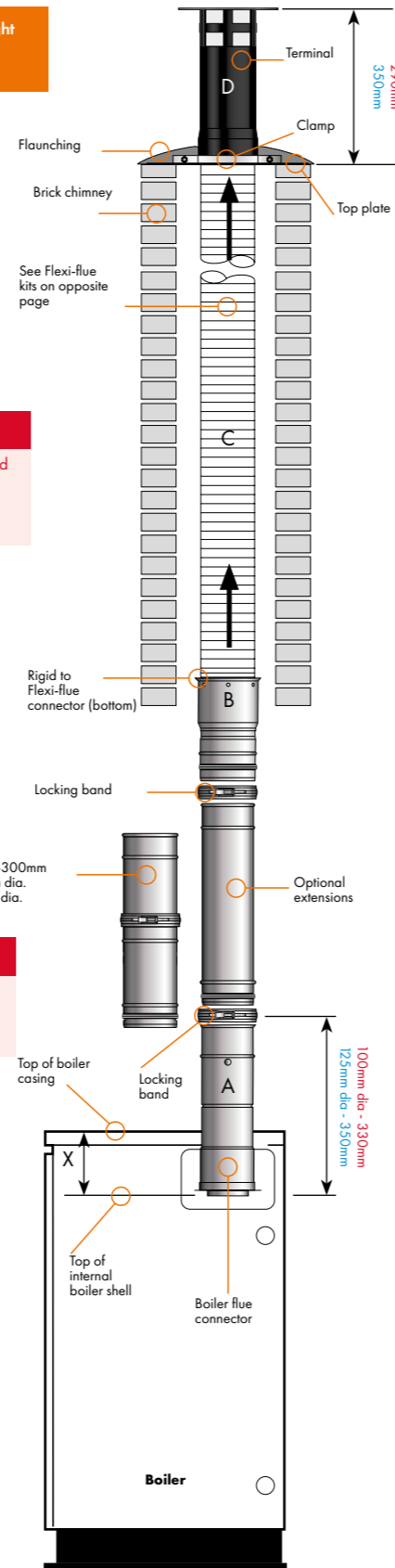

Top casing height = X	
Model	X dimensions (mm)
Vortex Pro 15-26	170
Vortex Eco 15-21 & 21-26	170
Vortex Pro 26-46	205
Vortex Eco 26-35	205
Vortex Pro 46-70	225
Vortex Pro Combi 21 & 26	170
Vortex Pro Combi 36	205
Vortex Eco Wall Hung 16-21	165

Optional extras

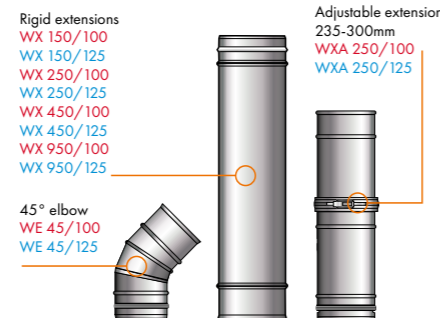

Smooth Bore Flexi-flue kits stainless steel

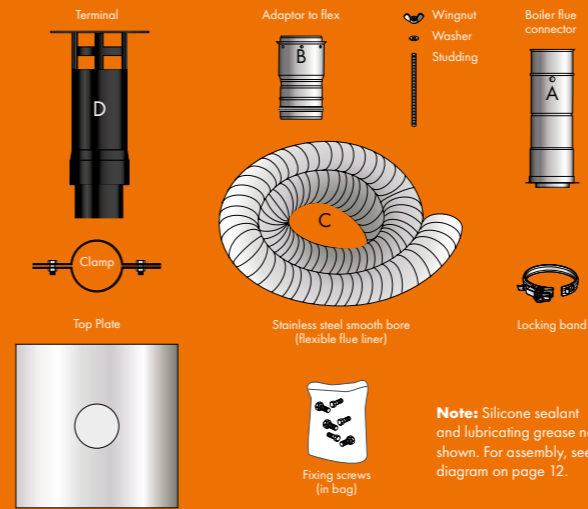

6 metre flexible flue kit	
GF KIT 6/100	Models up to 46kW
GF KIT 6/125	Models over 46kW

12 metre flexible flue kit	
GF KIT 12/100	Models up to 46kW
GF KIT 12/125	Models over 46kW

8 metre flexible flue kit	
GF KIT 8/100	Models up to 46kW
GF KIT 8/125	Models over 46kW

14 metre flexible flue kit	
GF KIT 14/100	Models up to 46kW
GF KIT 14/125	Models over 46kW

10 metre flexible flue kit	
GF KIT 10/100	Models up to 46kW
GF KIT 10/125	Models over 46kW

16 metre flexible flue kit	
GF KIT 16/100	Models up to 46kW
GF KIT 16/125	Models over 46kW

11 metre flexible flue kit	
GF KIT 11/100	Models up to 46kW
GF KIT 11/125	Models over 46kW

Flue extensions white powder coated (single skin)

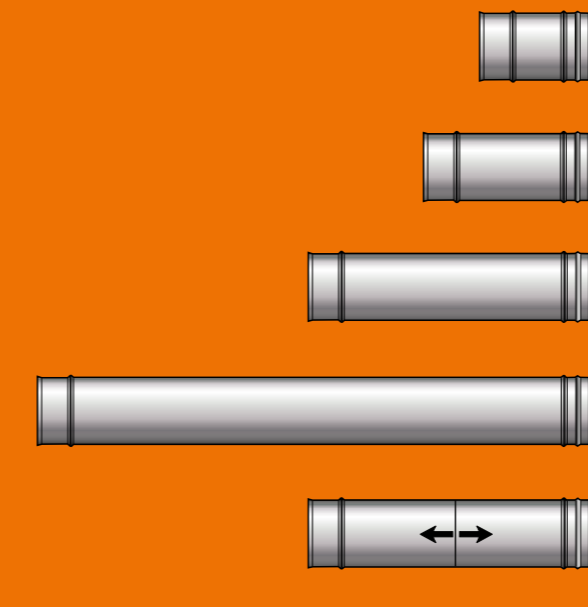

Extension 150mm c/w locking band	
WX 150/100	Models up to 46kW
WX 150/125	Models over 46kW

Extension 250mm c/w locking band	
WX 250/100	Models up to 46kW
WX 250/125	Models over 46kW

Extension 450mm c/w locking band	
WX 450/100	Models up to 46kW
WX 450/125	Models over 46kW

Extension 950mm c/w locking band	
WX 950/100	Models up to 46kW
WX 950/125	Models over 46kW

Adjustable extension 235-300mm c/w locking band	
WXA 250/100	Models up to 46kW
WXA 250/125	Models over 46kW

Important
Flue extensions cannot be cut. Orange system extensions are for vertical use only and cannot be used with Yellow or White system components.

Accessories white powder coated

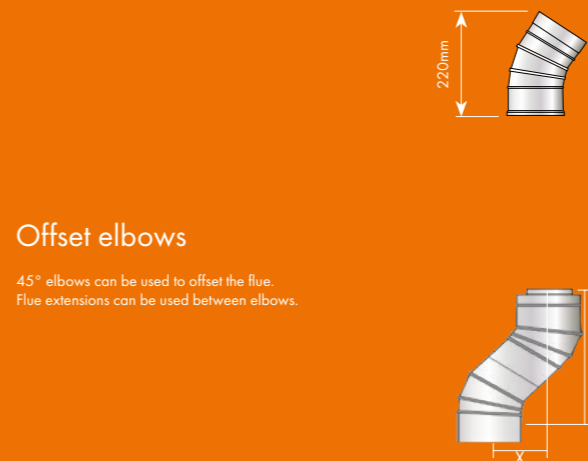

45° elbow c/w locking band	
WE 45/100	Models up to 46kW
WE 45/125	Models over 46kW

Important
Wherever possible incorporate one adjustable section. No more than two 45° elbows can be used.
Extension lengths given are effective lengths i.e. When fitted in a flue system.

Offset elbows

45° elbows can be used to offset the flue. Flue extensions can be used between elbows.

Code	X	Y
WE45/100	126	304
WE45/125	142	343

Hybrid Orange to Green flue system

Using components from the Grant Orange and Green flue systems it is possible to construct bespoke flue systems to overcome specific boiler siting problems.

See page 65 for white powder coated internal Orange system components and pages 63 & 67 for external Green system and adaptors.

For further information contact the Technical Department on 01380 736920.

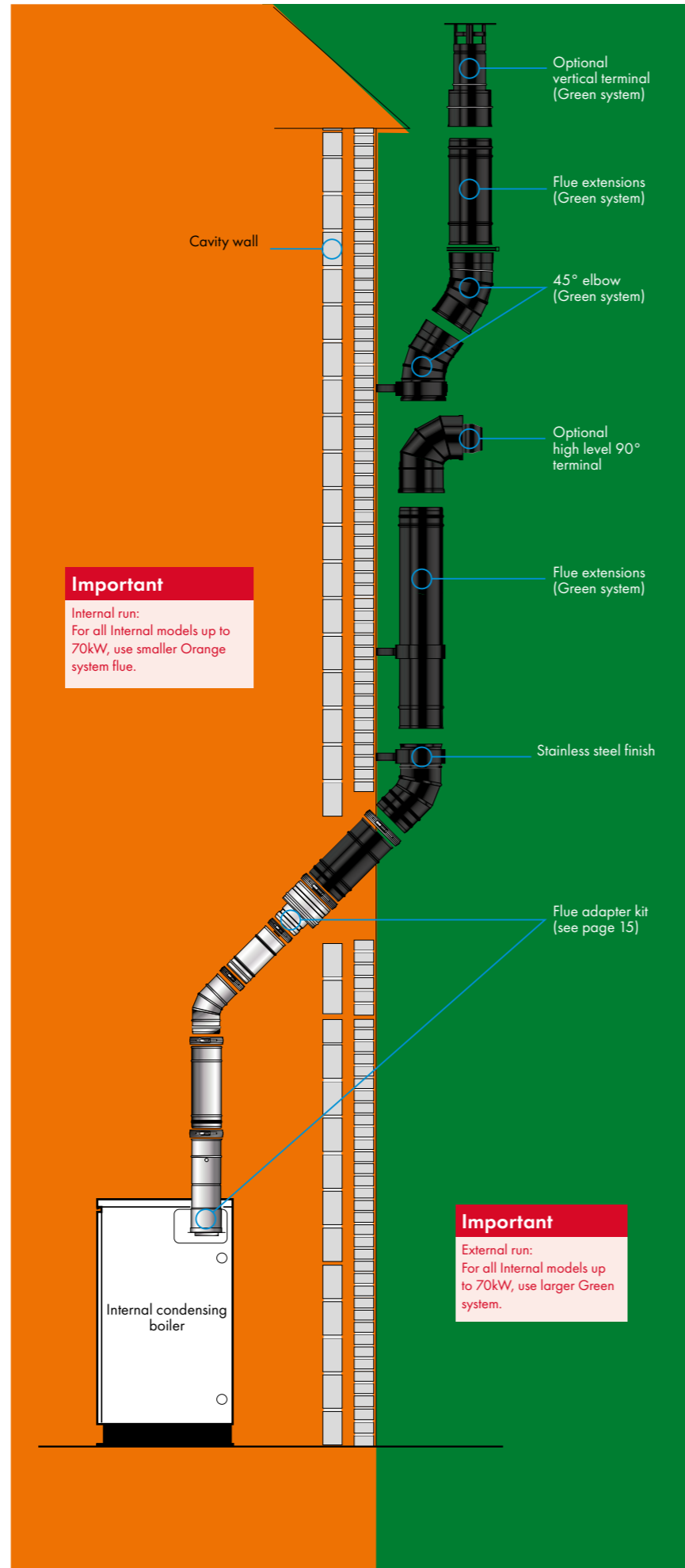

Important
Internal run:
For all Internal models up to 70kW, use smaller Orange system flue.

Important
External run:
For all Internal models up to 70kW, use larger Green system.

External Green system - Outdoor module (including wall hung)

Vertical solutions

See page 11 for extensions, elbows and terminals.

Note: Use starter straight connector for vertical extension.

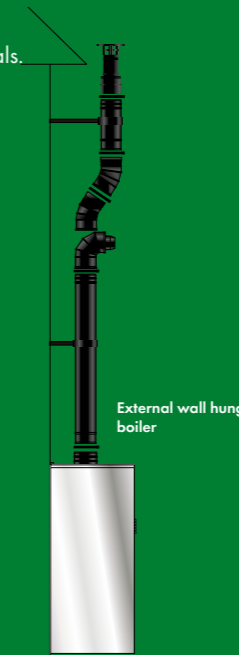

See page 11 for extensions, elbows and terminals.

Important
Components from the Orange and Green system can be used to construct Internal High Level, or Vertical Conventional flue systems using the flue adaptor kit CFA 15/70.

Maximum vertical length 19 metres

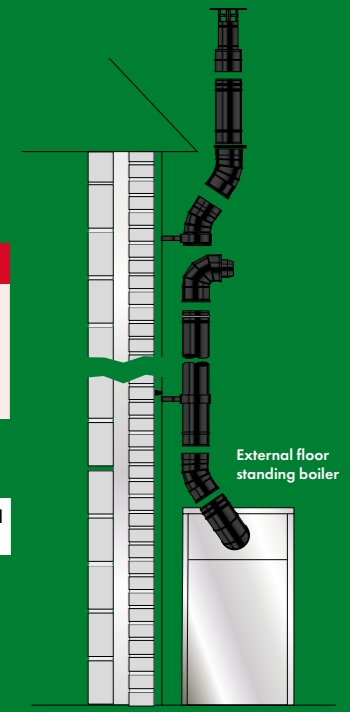

Accessories

External modules only

Important

* For Vortex Eco External 26-35kW models, use smaller size flue pipe.

	External module starter straight	
	GKM90C	Models up to 26kW*
	External module starter elbow c/w test point	
	GKM90B	Models up to 26kW*
	Straight terminal only	
	GTL90B	Models up to 26kW*
	GTL200B	Models over 26kW

Horizontal solutions

See page 11 for extensions, elbows and terminals

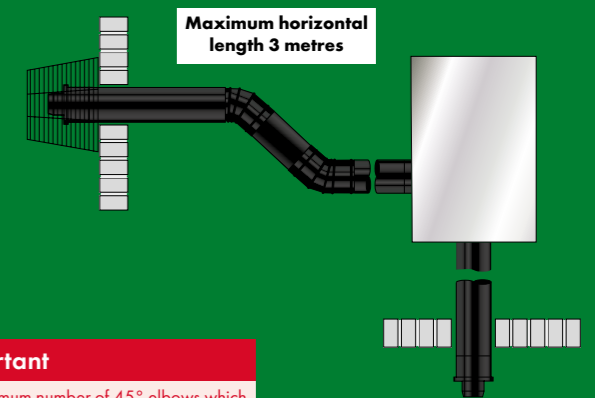

Maximum horizontal length 3 metres

Important
The maximum number of 45° elbows which can be used is two.

Flue adapter kit

For internal boilers only. See page 11 for extensions, elbows and terminals.

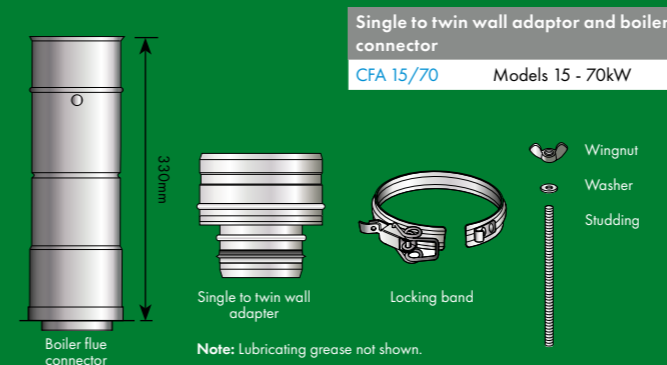

Single to twin wall adaptor and boiler connector
CFA 15/70 Models 15 - 70kW

Note: Lubricating grease not shown.

Starter connectors

The starter elbow converts any of Grant's external modules or module combis to High Level or Vertical Conventional flue operation.

The starter straight connector allows the low-level discharge flue system of any Grant External boilers to be extended horizontally. The stainless steel flue components are fully insulated, have 'O' ring seals and locking bands, ensuring a rigid construction every time.



Grant Engineering (UK) Ltd
sales@grantuk.com | grantuk.com | +44 (0)1380 736920