



BY HEATRAESADIA



DATA SHEET

Megaflo Eco Direct

UNVENTED CYLINDER

Megaflo Eco unvented cylinders are your first choice for conserving energy while providing superior hot water performance, with a 30* year warranty for total peace of mind in domestic installations. Made in the UK from high quality duplex stainless steel, Megaflo Eco is unrivalled in delivering high power showering and fast filling baths, even at low pressures. Featuring our internal expansion system, installation is quicker and easier too.

76
l/min
at 3 bar

MAX FLOW

12
kW

MAX INPUT

70-300
Litres

NOMINAL CAPACITY

60
mm

INSULATION



FEATURES

- Internal expansion with floating baffle
- New robust and safe handle
- Insulated T&P valve and 60mm thick cylinder insulation
- Titanium elements
- High grade duplex stainless steel
- Megaflo Eco delivers up to 76 litres per minute of hot water at 3 bar pressure

BENEFITS

- Neat appearance, saves space and reduces installation time
- For improved manoeuvrability
- Best possible heat retention and energy efficiency
- The highest quality elements, specially designed for longer life in even the most aggressive or corrosive water conditions
- High corrosion resistance and a high strength to weight ratio
- Outstanding hot water performance without the need for shower pumps or tanks, even at low pressures

*30 year warranty on inner tank for all Megaflo cylinders and 2 years for all other components

Megaflo Eco Direct

UNVENTED CYLINDER

SPECIFICATIONS

Model	70D	125DD	145DD	170DD	210DD	250DD	300DD
Product code	95050460	95050462	95050464	95050466	95050468	95050470	95050473
Nominal capacity (litres)	70	125	145	170	210	250	300
Internal expansion with floating baffle	√	√	√	√	√	√	√
Insulation thickness (mm)	60	60	60	60	60	60	60
Immersion heater rating (No. x kW)	1 x 3	2 x 3	2 x 3	2 x 3	2 x 3	2 x 3	2 x 3
Weight empty (kg)	23	25	31	34	38	46	56
Weight full (kg)	115	165	183	216	237	282	339
Standing heat loss (kWh/24h)	0.91	1.05	1.18	1.2	1.42	1.61	1.69
Standing heat loss (kWh/year)	332.15	383.25	430.2	438	518.3	587.65	616.85
Max flow at 3 bar (l/min)	76	76	76	76	76	76	76
Max flow at 1 bar (l/min)	45	45	45	45	45	45	45
Heat up time using all available elements	92	71	79	93	102	121	146

ERP TECHNICAL DATA

Storage volume V in litres @ 3 bar	92	140	155	182	199	236	283
Mixed water at 40°C V40 in litres	78	167	183	218	241	307	359
The declared load profile	M	M	M	L	L	L	XL
The water heating energy efficiency class of the mode	B	B	C	C	C	C	C
The water heating energy efficiency in %	38.6	39.2	37.5	38.2	37.5	37.8	37.7
The annual electricity consumption in kWh	TBC	1311	1369	2682	2731	3513	4443
The daily electricity consumption in kWh	6.110	6.010	6.350	12.380	12.670	20.480	20.580
The thermostat temperature settings of the water heater, as placed on the market by the supplier	60°C	60°C	60°C	60°C	60°C	60°C	60°C

TECHNICAL SPECIFICATION

Maximum supply pressure to incoming mains cold water combination valve (supplied)	1.6 MPa (16 bar)
Minimum recommended supply pressure and flow rate	0.15 MPa (1.5 bar) – 20 litres per minute
Operating pressure	0.3 MPa (3 bar)
Inner water container	High grade duplex stainless steel pressure tested to 15 bar
Thermal insulation (nominal thickness 60mm)	CFC/HCFC free, fire retardant expanded polyurethane foam with zero ozone depletion Global warming potential (GWP) = 3.1
Pressure relief valve	0.8 MPa (8 bar)
Immersion heater rating (AC supply only)	3kW @ 240V 2.8kW @ 230V
Connections	22mm compression / 3/4" BSP
Domestic hot water expansion	Accommodated by an internal air gap system complete with a floating baffle, negating the need for an external expansion vessel

COMPONENTS

The following components are supplied as standard with Megaflo Eco Direct

Immersion(s)	Factory fitted immersion heater(s) and thermal controls. Titanium elements.
Cold water	Cold water inlet control kit comprising of 0.3MPa (3 bar) pressure reducing valve, 0.8MPa (8 bar) pressure relief valve (BS EN 1567, BS EN1491, EN 13959) 1/4 turn isolating valve, line strainer, non-return valve, drain valve with hose connection, nuts and olives
Safety	Factory fitted temperature and pressure relief valve set at 90°C / 1 Mpa (10 bar) (BS EN 1490) inc. T&P valve insulation kit 15/22mm Tundish

210DDD	250DDD	300DDD	210DDDD	250DDDD	300DDDD
95050480	95050471	95050474	95050476	95050477	95050478
210	250	300	210	250	300
√	√	√	√	√	√
60	60	60	60	60	60
3 x 3	3 x 3	3 x 3	4 x 3	4 x 3	4 x 3
39	47	57	40	48	58
237	282	339	237	283	339
1.42	1.61	1.69	1.42	1.61	1.69
518.3	587.65	616.85	518.3	587.65	616.85
76	76	76	76	76	76
45	45	45	45	45	45
68	81	97	51	60	73

236	236	236	283	283	283
307	307	307	359	359	359
L	L	XL	L	L	XL
C	C	C	C	C	C
37.5	37.8	37.7	37.5	37.8	37.7
2731	3513	4443	2731	3513	4443
12.670	20.480	20.580	12.670	20.480	20.580
60°C	60°C	60°C	60°C	60°C	60°C

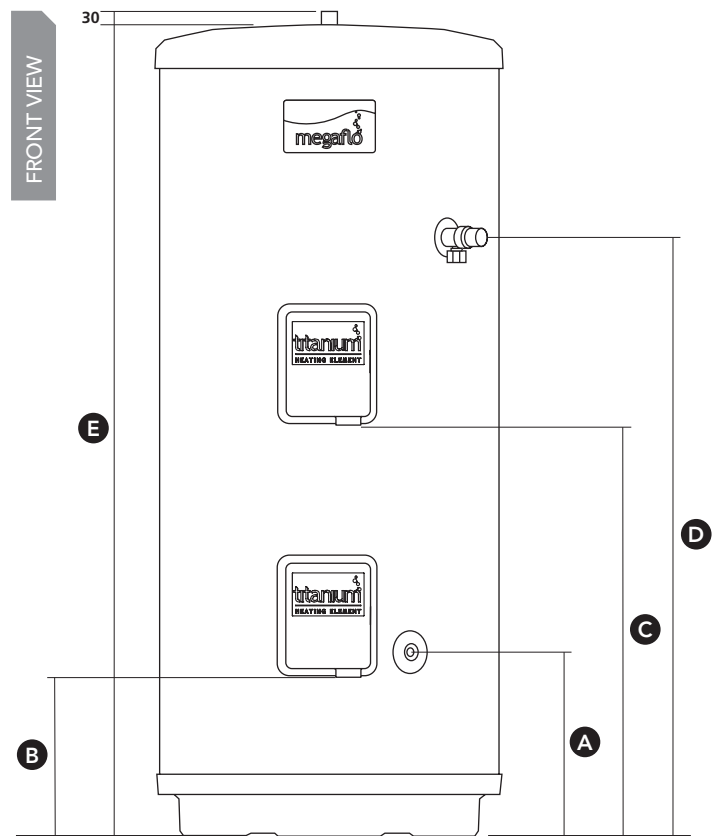
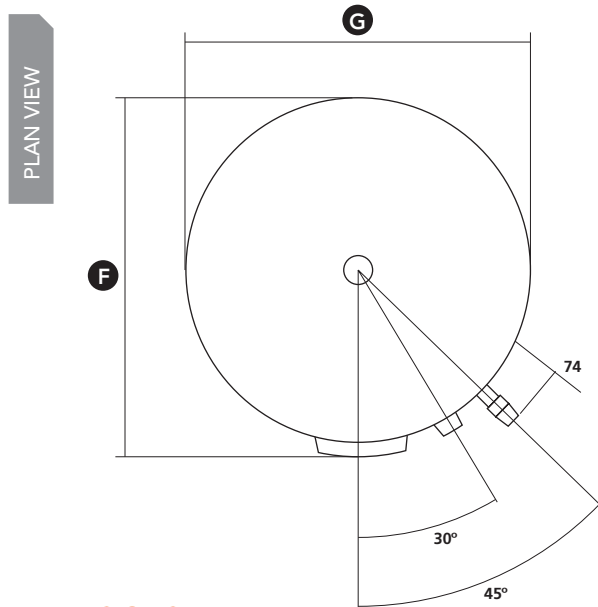

DIMENSIONS

Model	70D	125DD	145DD	170DD	210DD	250DD	300DD	210DDDD	250DDDD	300DDDD	210DDDD	250DDDD	300DDDD
A DHW inlet (mm)	414	414	414	414	414	414	414	414	414	414	414	414	414
B Cable entry lower (mm)	275	275	275	275	275	275	275	275	275	275	275	275	275
C Cable entry upper (mm)	-	549	580	705	801	1009	1313	801	1009	1313	801	1009	1313
D T&P relief valve (mm)	495	794	895	1020	1095	1323	1574	1095	1323	1574	1095	1323	1574
E Height (mm)	802	1102	1229	1384	1486	1738	2053	1486	1738	2053	1486	1738	2053
F Depth (mm)	600	600	600	600	600	600	600	600	600	600	600	600	600
G Width (mm)	579	579	579	579	579	579	579	579	579	579	579	579	579



BY HEATRAESADIA



DATA SHEET

Megaflo Eco Direct

UNVENTED CYLINDER

CODES OF PRACTICE/LEGISLATION

EU Directives:

- Pressure Equipment Directive 97/23/EC.
- Low Voltage Directive (LVD) 2014/30/EU.
- RoHS (Restriction of use of certain Hazardous Substances) Directive 2011/65/EU.
- Electromagnetic Compatibility (EMC) Directive 2014/35/EU.

Legislation:

- Building Regulations Part G and Part L (England and Wales).
- Scottish Building Standards Section 4 and Section 6.
- Building Regulations (Northern Ireland) Parts F1 and F2 and Part P.
- Water Supply (Water Fittings) Regulations (England and Wales).
- The Water Byelaws 2004 (Scotland).
- Water Supply (Water Fittings) Regulations (Northern Ireland).

Standards:

- Relevant clauses of the following standards are complied with:
- EN 12897 - Specification for indirectly heated unvented cylinders.
- EN 60335-2-21 - Safety-Particular requirements for storage water heaters.
- The stainless steel materials used comply with the relevant clauses of:
- EN 10088 - Technical delivery conditions for sheet/plate and strip of corrosion resisting steels for general purposes.

Components supplied comply with the following standards:

- BS EN 1490 Building Valves - Combined Temperature and Pressure Relief Valves.
- BS EN 1491 Building Valves - Expansion Valves.
- BS 6144 Specification for Expansion Vessels Using An Internal Diaphragm For Unvented Water Supply Systems.
- BS EN 1567 Building Valves - Water Pressure Reducing Valves and Combination Reducing Valves.
- BS EN 60730-1 Automatic Electrical Controls - For households and similar use. Part 1: General Requirements.
- BS EN 60730-2-8 Automatic Electrical Controls - Particular Requirements for Electrically Operated Water Valves.
- BS EN 13959 Anti-pollution Check Valves.

The use of these water heaters will aid in compliance with:

- Health and Safety Executive Approved Code of Practice L8: The control of legionella bacteria in water systems.
- BS EN 806 Parts 1 to 5: Specification for installations inside buildings conveying water for human consumption.
- BS 8558 Guide to the design, installation, testing and maintenance of services supplying water for domestic use within buildings.
- Chartered Institute of Building Services Engineers Guide B and Guide F.

Manufactured in a factory approved to:

- BS EN ISO 9001
- OHSAS 18001
- ISO 50001
- ISO 14001

Megaflo Eco approvals:

- Kiwa Certification Number: 1608707
- Nemko Certification Number: P10213136/A6



For more information
0344 871 1535 | heatraesadia.com
megaflo.com



Please recycle this product once you have finished with it

Issue 7 2023

MEGAFLO may introduce modifications to their products from time to time. Consequentially the details given in this data sheet are subject to alteration without notice.