





INSTALLATION MANUAL

One Way Thermostatic Shower



Tools Needed



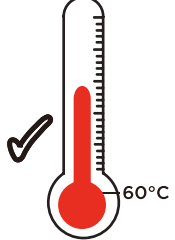

Maximum Hot 60°C

Dynamic Water Pressures

Min: 0.2 bar Max: 5.0 bar

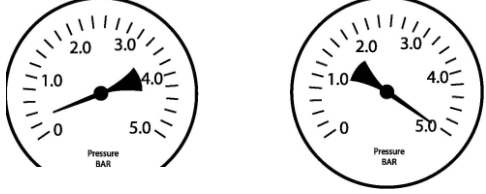

Maximum Static Pressure: 10.0 bar

Troubleshooting

Symptom	Cause	Remedy
No flow or low flow rate	Partially closed isolation valve.	Open isolation valve.
	Instantaneous water heater cycles on and off as flow rate or pressure is too low.	Increase water flow rate or pressure through system.
	Head of water is below the minimum distance required.	Refer to specification for minimum distance required.
	Hot or cold water being drawn off elsewhere causing pressure changes or instantaneous boiler temperature changes.	Do not use other water outlets when using the taps.
	Airlock or partial blockage in the supply pipework.	Flush through pipework to ensure removal of debris and any airlocks.
Water dripping from taps	This is normal for a short time after using the taps.	This is caused by residual water tension, the build up of water in the tap body.
	If water continues to drip, possibly due to the ceramic disc valves	Remove valves and clean, refer to 'Maintenance' section before starting any maintenance.
Taps do not turn on	Closed isolation valve.	Open isolation valve.
	Mains water supply turned off.	Turn on mains water supply.

1. NOTES FOR INSTALLATION

Warning: Please read the instructions completely before proceeding.

- 1) The installation must comply with the "Water Supply Regulations 1999 (Water Fittings)" any particular regulations and practices specified by the local water company.
- 2) Minimum and Maximum working pressure : 0.2 - 5 bar. If the pressure exceeds 5.0 bar, as pressure relief valve MUST be installed.
- 3) The shower valve must be installed on strong wall/surface which can support the weight of the valve.
- 4) Please do not connect hot and cold water supply lines in reverse. This could result in scalding.
- 5) The hot water temperature must not exceed 60°C. Exceeding 60°C may cause scalding, the service life of your shower might be shortened, or the product might be damaged.
- 6) The temperature marking is pre-set at the factory. The temperature can vary +/- 2 degrees which is within normal safety standards.
- 7) The working pressure of both cold and hot water must not vary by more than 20%.

2 SHUT OFF WATER SUPPLY

Locate water supply inlets and shut off the water supply valves. These are usually found under the sink or near the water meter.

3 TOOLS RECOMMENDED

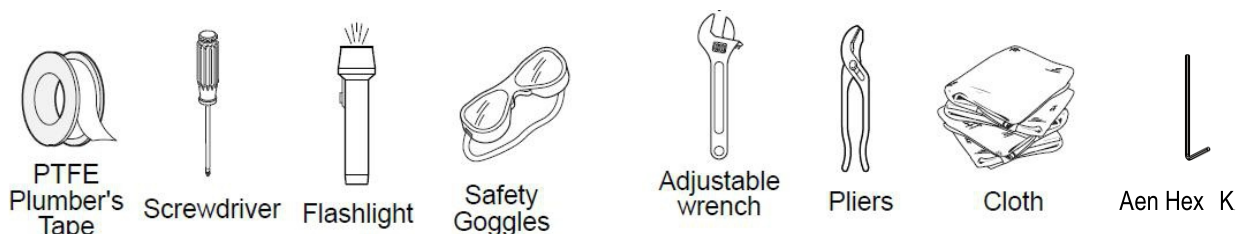

4 INSTALLATION

4.1 INSTALLATION OF FLANGES

Apply proper quantity of plumber's tape or thread tape to the end of the S-shape connectors. Screw them into the hot & cold pipes. Adjust the positions of connectors until the centre distance is 150mm and projection parts remain at same horizontal level. Fix the flanges onto the connectors and reach against the wall.

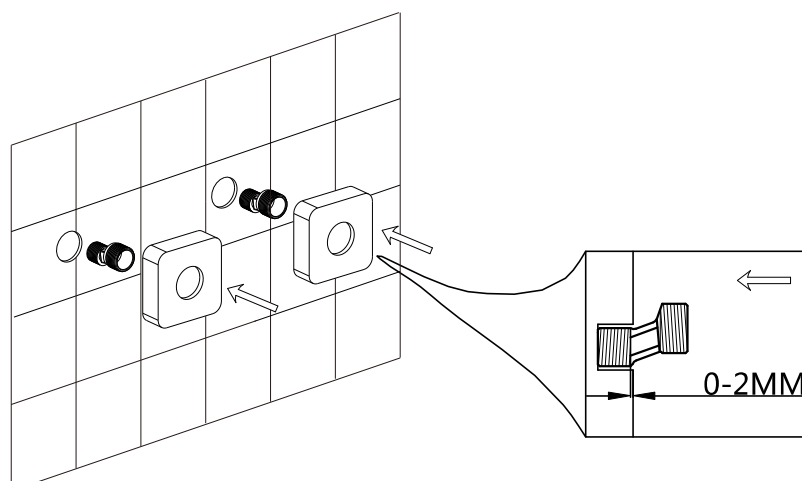

4.2 INSTALLATION OF SLIDING BAR

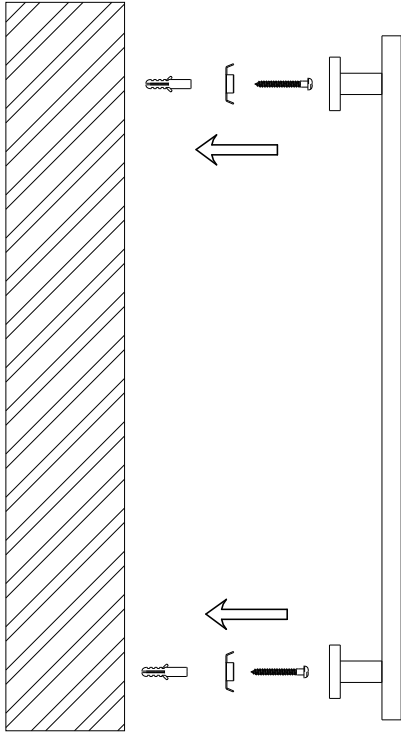

4.3 INSTALLATION OF THERMOSTATIC VALVE

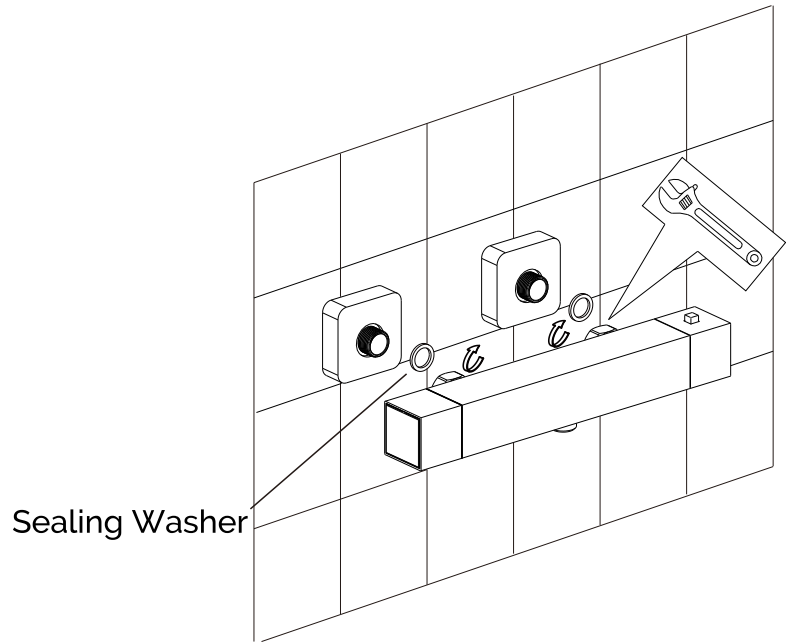

4.4 LEAKAGE TESTING

Turn on the valve as shown in the picture, to check if there is leakage at the connections. Keep the valve opened for one minute to remove impurities.

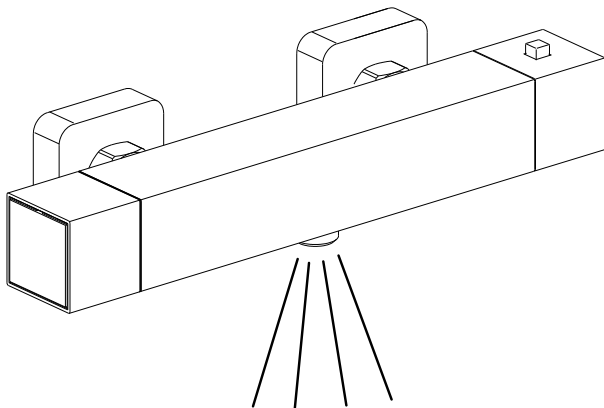

4.5 INSTALLATION OF SHOWER HOSE & HANDSHOWER

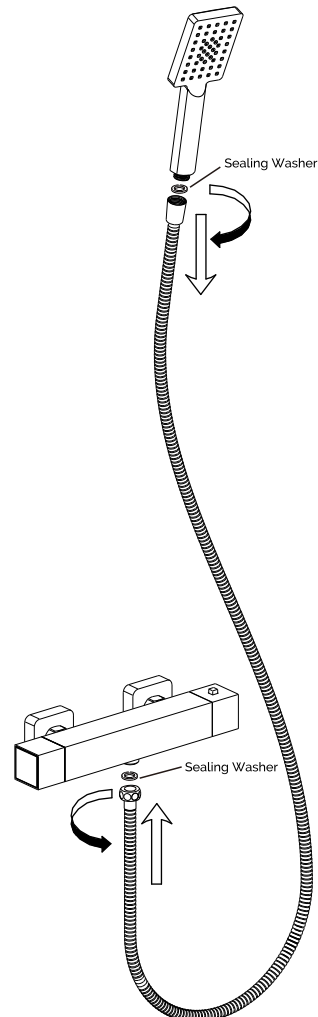

5. VALVE CONTROLS / FUNCTIONS

Rotate the thermostatic control handle to adjust the water temperature. Water temperature decreases when the handle is turned clockwise, and increases when the handle is turned in anti-clockwise. The thermostatic valve includes a safety button to prevent scalding, which is pre-set at 38°C. To obtain higher temperature, push down the button and continue to rotate anti-clockwise. In case of a fast change or imbalance of hot or cold water pressure the safety mechanism stops water flow automatically. On handle select either hand shower or overhead shower.

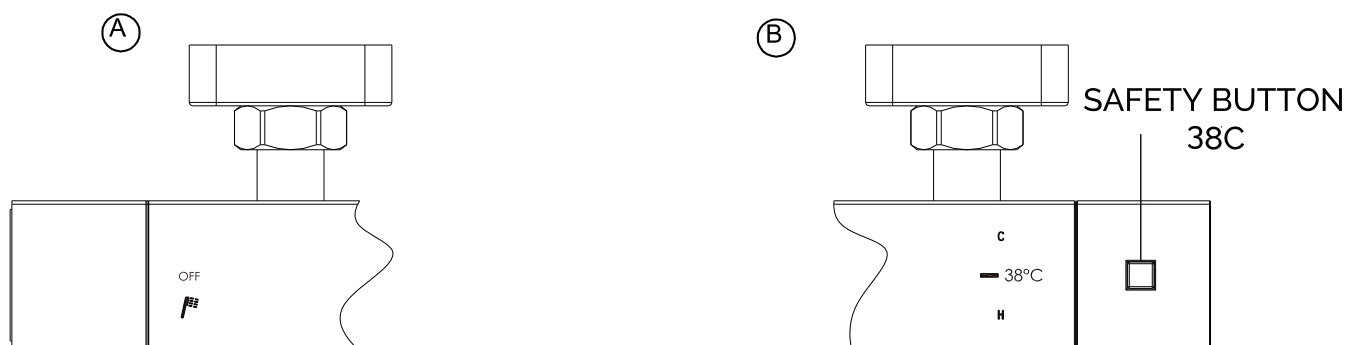

DIVERTOR OVERHEAD & HANDSHOWER THERMOSTATIC TEMPERATURE CONTROL

6. INSTALLATION AND REPLACEMENT OF CARTRIDGE

Turn off the supply valves with screwdriver. Disassemble the thermostatic control handle set (1, 2, 3), lock (5), and locknut (6,7) with adjustable wrench. Take out the thermostatic cartridge (10) for cleaning or replacement. Assemble the cartridge onto the valve body in opposite order as above. Reminder - please keep the temperature mark 38°C of the cartridge in line with the mark on the body.

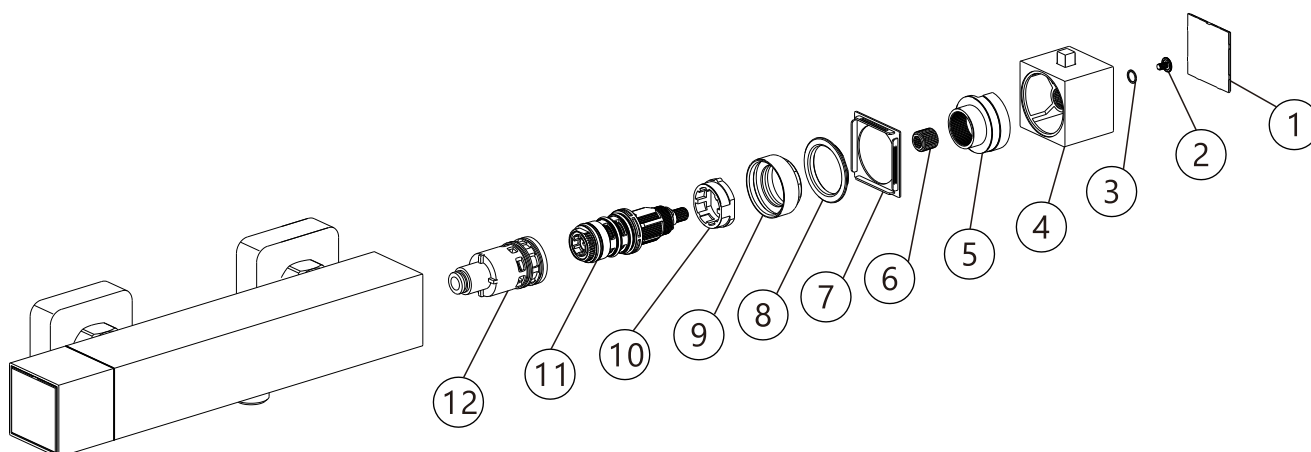

7. CLEANING / MAINTENANCE

For all decorative finishes, use only a soft damp cloth to clean and shine. Use of polish, detergents, abrasive cleaners, organic solvents or acid may cause damage. Use of other than a soft damp cloth will nullify our warranty.

