

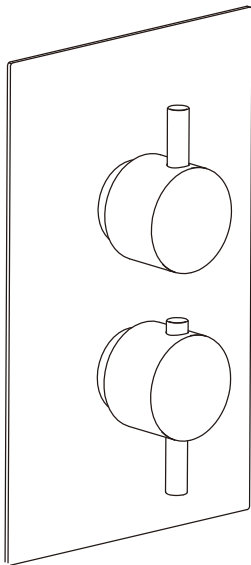

INSTALLATION MANUAL

One Way Thermostatic

Shower



Abingdon

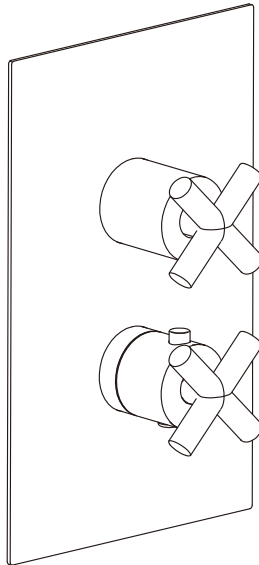

Calm

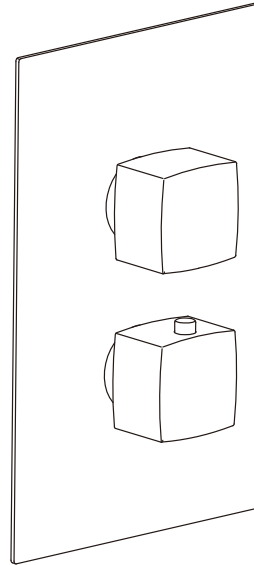

Holton

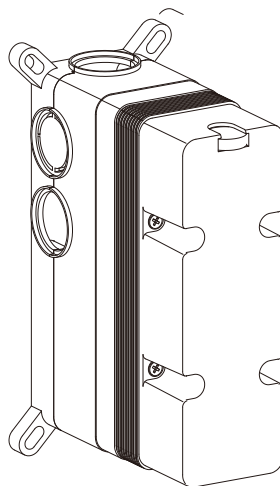

Easy box included

Tools Needed

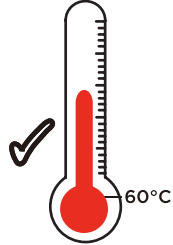

Maximum Hot 60°C

Dynamic Water Pressures

Min: 0.2 bar

Max: 5.0 bar

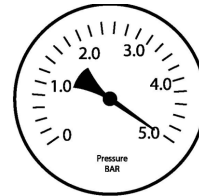
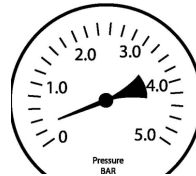

Maximum Static Pressure: 10.0 bar

1. NOTES FOR INSTALLATION

Warning: Please read the instructions completely before proceeding.

The installation must comply with the "Water Supply Regulations 1999 (Water Fittings)" any particular regulations and practices specified by the local water company.

Minimum and Maximum working pressure : 0.2 - 5 bar. If the pressure exceeds 5.0 bar, as pressure relief valve MUST be installed.

The shower valve must be installed on strong wall/surface which can support the weight of the valve.

Please do not connect hot and cold water supply lines in reverse. This could result in scalding.

The hot water temperature must not exceed 60°C. Exceeding 60°C may cause scalding, the service life of your shower might be shortened, or the product might be damaged.

The temperature marking is pre-set at the factory. The temperature can vary +/- 2 degrees which is within normal safety standards.

The working pressure of both cold and hot water must not vary by more than 20%.

2 SHUT OFF WATER SUPPLY

Locate water supply inlets and shut off the water supply valves. These are usually found under the sink or near the water meter.

3 TOOLS RECOMMENDED

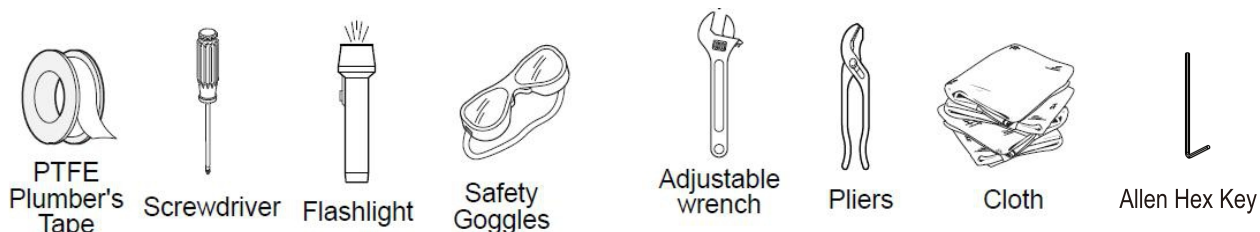

4 INSTALLATION

4.1 INSTALLATION OF FLANGES

Apply proper quantity of plumber's tape or thread tape to the end of the S-shape connectors. Screw them into the hot & cold pipes. Adjust the positions of connectors until the centre distance is 150mm and projection parts remain at same horizontal level. Fix the flanges onto the connectors and reach against the wall.

Fig 1.

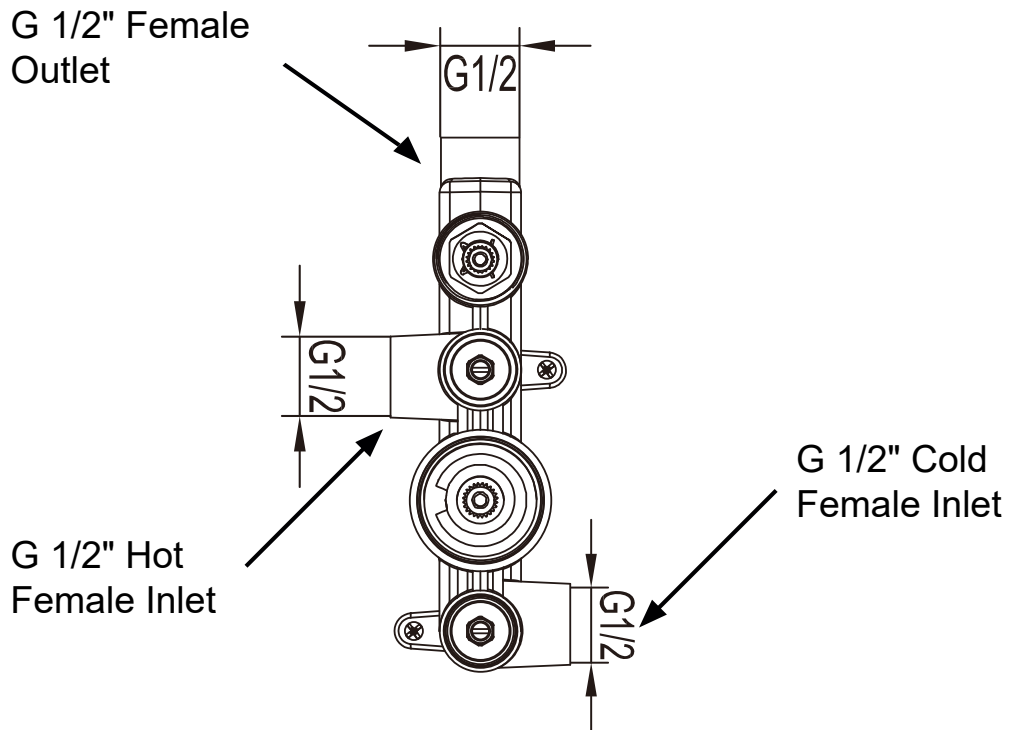
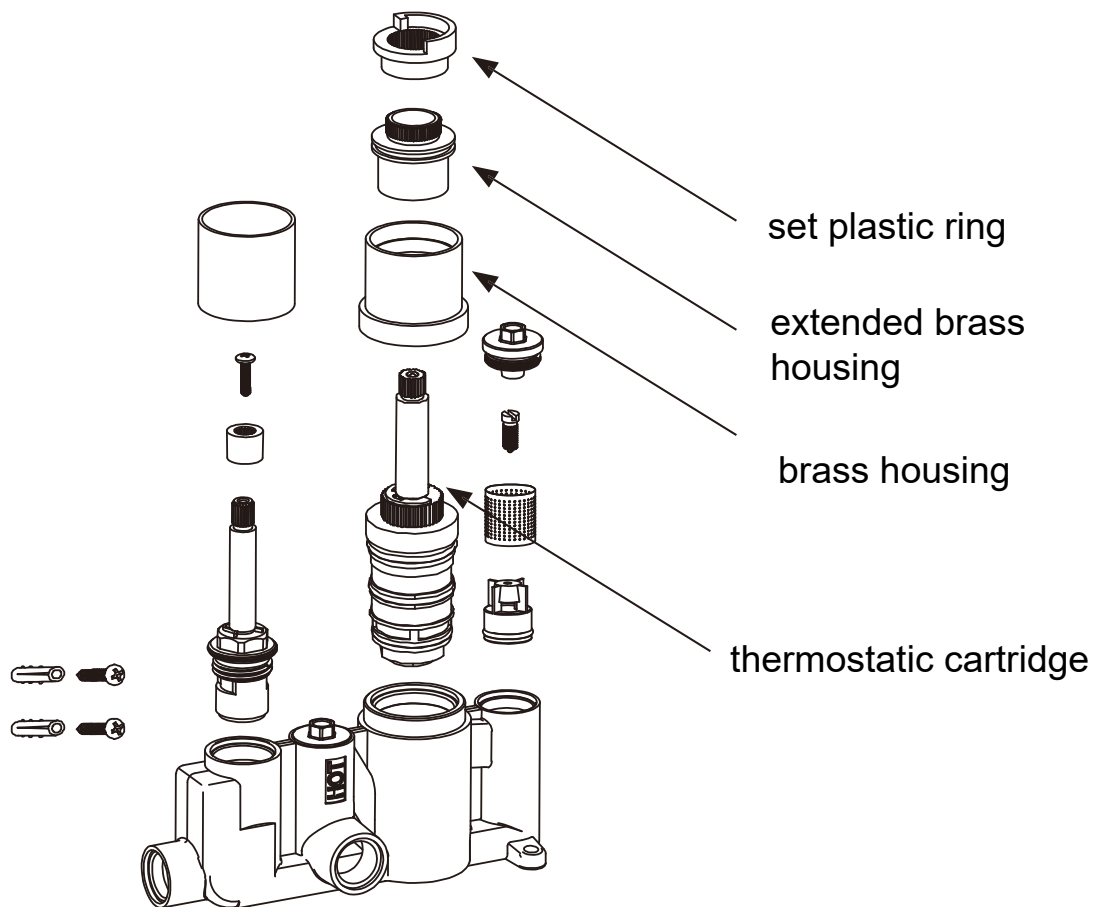

Fig 2.



Installation:

1. Determine the fixing position for the valve and make a recess in the wall to house the valve. The depth of the recess should be 83mm to 98mm within the finished wall surface to fit the cover plate correctly.
2. Insert the valve into the wall recess, then mark the fixing points with the mounting lugs that are cast on the valve body. Pull the valve out and drill suitable length holes at the marked positions. Insert the supplied rawl plugs into the pre-drilled holes.
3. Prior to installation and connecting make sure that the pipes are thoroughly flushed to remove any debris etc. (failure to do this will impair the flow of the water).
4. The Plumbing connections should then be made to the hot and cold inlets which are clearly marked (**see Fig. 1**). The hot water inlet is to be connected with the hot supply on the left of the valve and the cold water inlet is to be connected to the cold supply on the right of the valve. Make sure that they are correctly connected, otherwise the thermostatic cartridge will lose it's function of controlling the temperature and may scald.
5. Make the plumbing connection to the water outlet. This will take the water to the chosen shower kit you have selected to run with this shower. The plumbing connections on the inlets and outlets are 1/2" BSP female thread. It is recommended to apply PTFE tape to all thread connections to ensure a water tight seal.
6. Place the valve body over the holes and secure into place using the screws provided.
7. Turn on the water supply to ensure that there are no leakages.
8. Slide the plate into position over the lock sleeve and fit this up against the wall surface.
9. Fit the control handles making sure that the stop lug (of the bottom stop ring) is positioned at "12 O' clock" and that the markings of both stop rings (top & bottom) are in line. Remove any decorative caps then place the handle on the above stop ring; holding the handle firmly in position tighten, using the screw and Allen Key provided. Be careful not to turn the stop ring when tightening.

Fitting the handles:

1. Remove the arm from the control knob by unscrewing and detaching the protruding arm. Remove the threaded grub screw from within the control knob. Take care not to lose these items.
2. Place the control knob onto the valve shaft. Secure the control knob using the threaded grub screw and tighten with the Allen Key provided.
3. Finally, re-screw the arm back onto the control knob. Repeat this task for the other control handle.

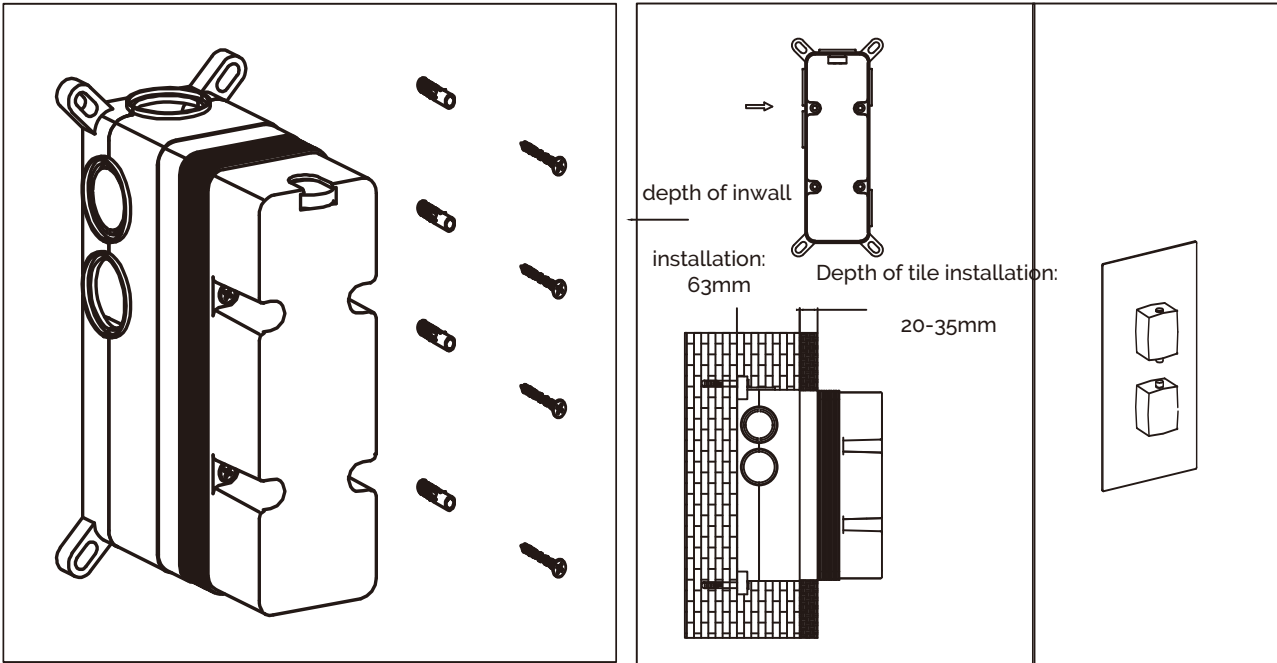

1

Flush the pipeline

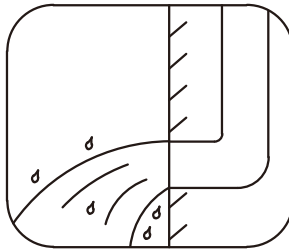

Remove Easy Box cover

2

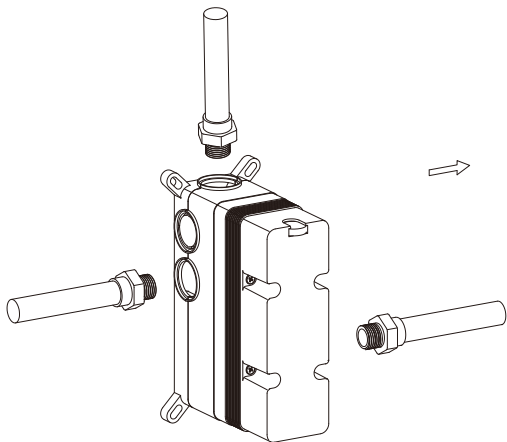

3

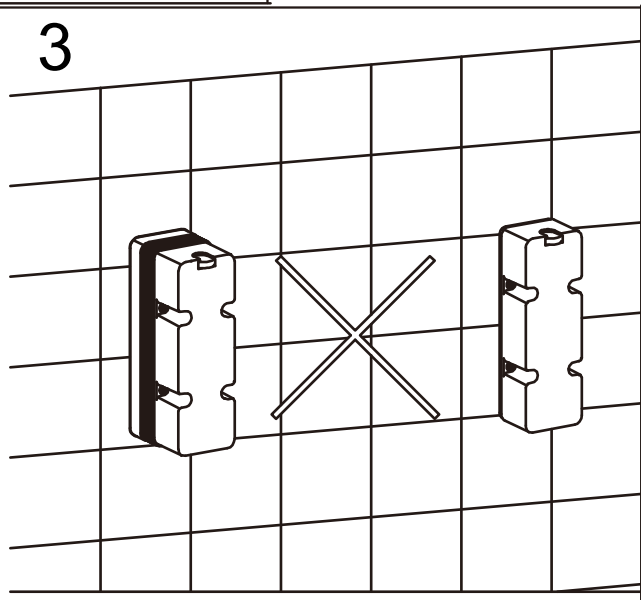

Discard any Easy Box material
and recycle waste

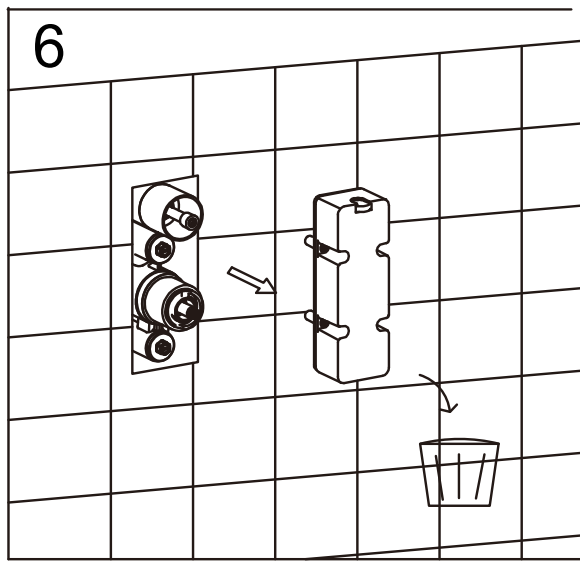
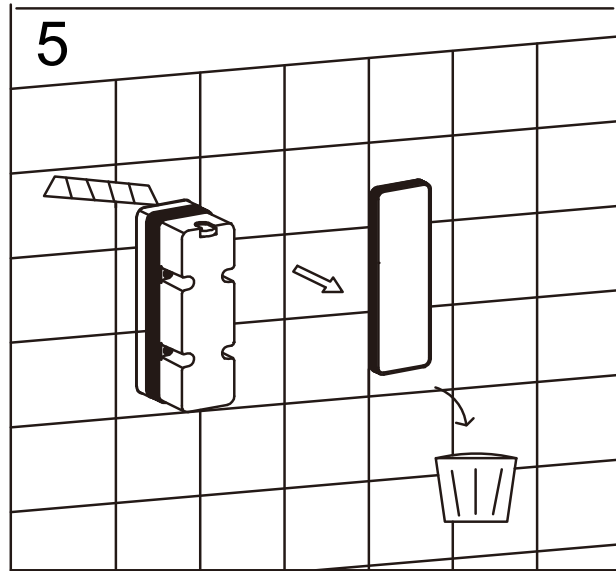
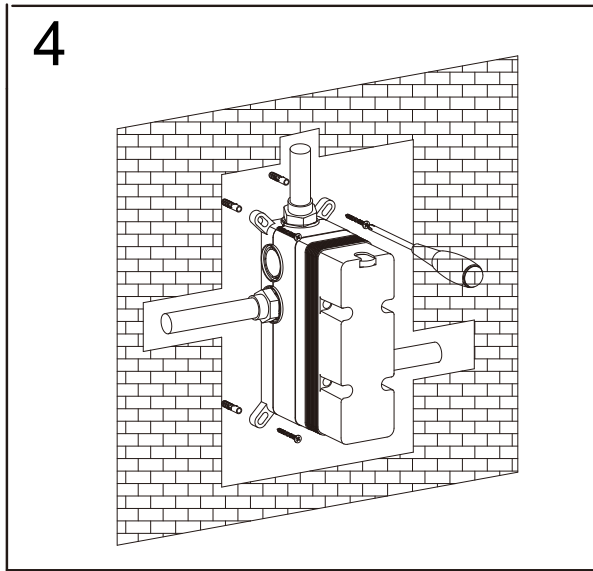

Open the valves 1 & 2 to flush through
any debris - extremely important

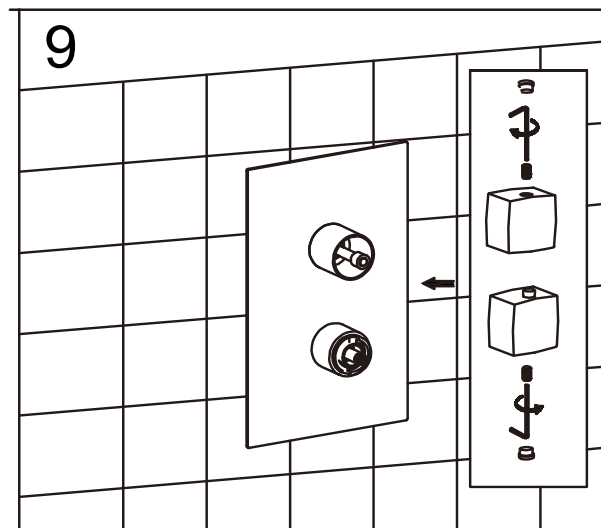
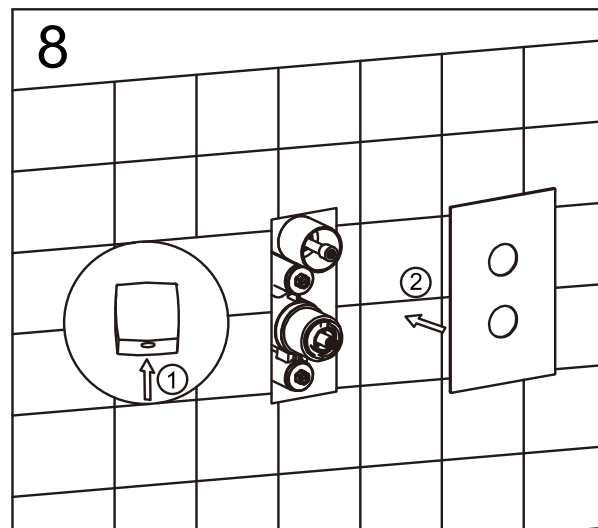
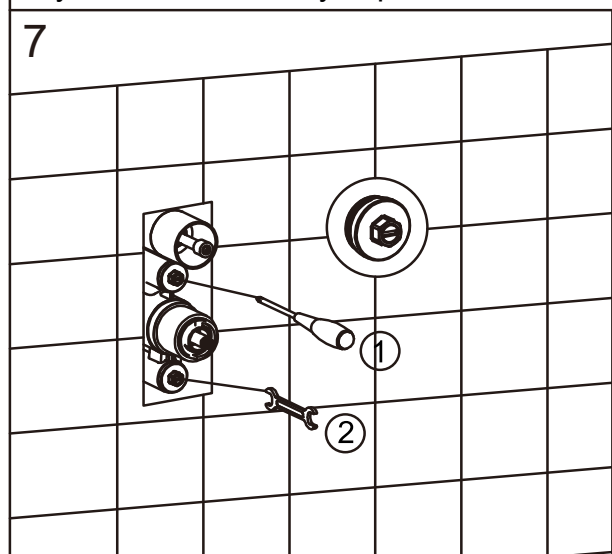

Operation

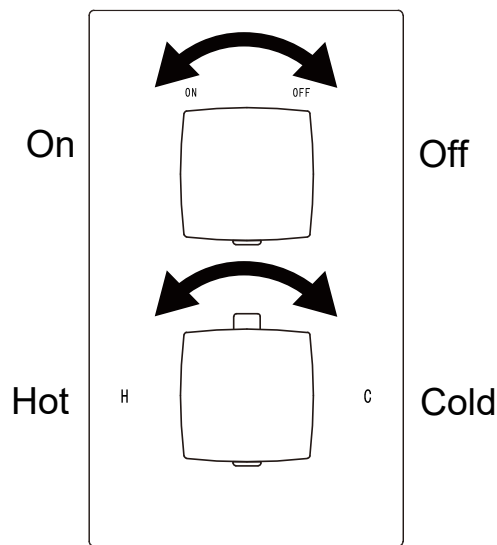

Ensure that the control handles are positioned correctly to avoid obstruction.

Maintenance:

If the water flow is less than normal and temperature control is imprecise after a period of usage. It is often due to the poor water which blocks the small filter net. The cleaning method: First, turn off the main valve, remove the control handles and cover plate. Then unscrew the end caps on the hot/cold water inlet sides of valve body with an Allen key. Now you can clean the small filter net with brush and vinegar. After completion, rinse it and reassemble all the parts back. At last, check the water flow and temperature control.

Aftercare:

Always clean the surface of shower valve to keep it bright. **Attention:** please do not use inappropriate tools such as sharp brushes, rough sponges, scouring pads or corrosive detergent to clean the shower valve. Please clean the shower valve by wet cloth and soapy water after each time of usage. Then rinse the soap out with clean water and dry with a soft cotton cloth.

FAULT	POSSIBLE CAUSE
Shower only runs hot or cold after installation	<ol style="list-style-type: none"> 1. Hot and cold supplies have been plumbed the wrong direction. 2. Faulty thermostat. 3. Insufficient water pressure.
Shower does not run hot enough	<ol style="list-style-type: none"> 1. Check the hot water supply temperature. 2. Maximum temperature needs adjusting, see temperature adjustment. 3. Blockage in the hot supply.
Hot water in cold supply or vice versa	<ol style="list-style-type: none"> 1. Check and clean non-return valves. 2. Check Hot and Cold supplies have not been reversed during installation.
Low or no flow	<ol style="list-style-type: none"> 1. Possible blockage/debris in the system. 2. Operating conditions are incorrect. 3. Valve shut off has been activated due to a pressure drop in either the cold or hot supplies.
Leaking when in the off position	<ol style="list-style-type: none"> 1. Debris in the flow control cartridge. 2. Faulty control cartridge.
Fluctuating flow	<ol style="list-style-type: none"> 1. Dynamic inlet pressure are not balanced.