

Keston

BY IDEAL HEATING

KESTON SYSTEM 2

30kW Output System Boiler



Easy to service



Twin Flue up to 27m*



Weather compensator



Compact cupboard fit



Frost protection



Large high resolution colour screen



Halo Heat & System compatible



Low component count maximising reliability

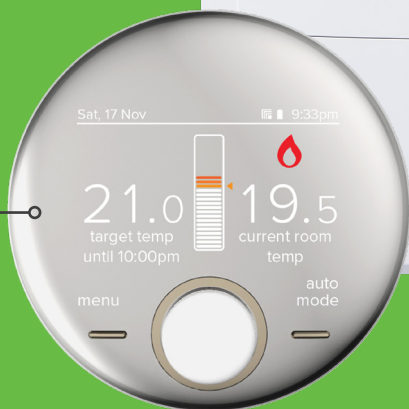

Features & specification

Keston System 2 boiler provides a simple and reliable solution for a wide variety of sealed domestic systems.

Available with a 30kW output, Keston System 2 provides a dependable and efficient solution for new and replacement installations. Time saving push & clip flue spigot connections and a wide range of alternative flueing solutions help to ensure the product is installed quickly in virtually any domestic situation.

With a lightweight design, concealed connections at the base and no compartment ventilation required, Keston System 2 can be conveniently fitted out of sight into a standard kitchen cupboard*.

Complete with a 7 year parts and labour warranty†, Keston System 2 boiler provides simple heating control, all from a single compact appliance.

THE FACTS

- 7 year warranty†
- Easy to see pressure gauge
- Large backlit display with user friendly controls
- Low lift weight
- Low component count maximising reliability
- Compact dimensions
- Twin flue up to 27m**
- 50mm muPVC (PVC-C) solvent weld flue allowing simple, cost effective installations***
- Weather compensation supplied as standard
- Inbuilt frost protection
- Fully modulating
- LPG conversion kit available

DIMENSION & CLEARANCES

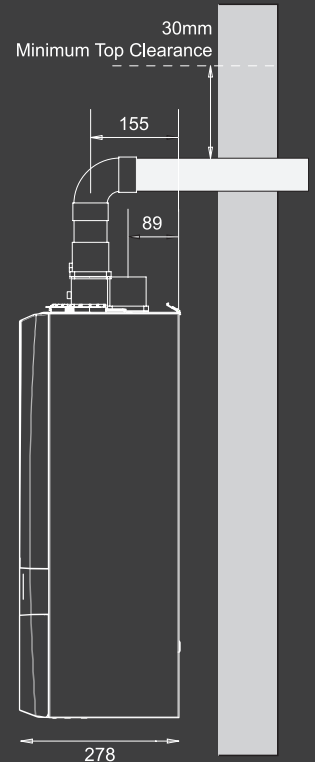
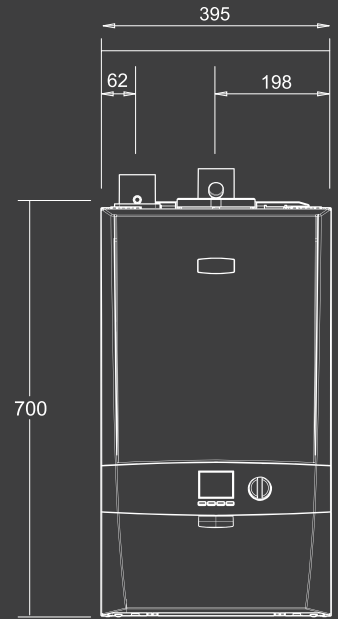

† 7 year warranty when installed with a Keston 22mm System Filter and registered within 30 days of installation. 5 year parts & labour warranty as standard. Terms and conditions apply.* Please check cupboard size prior to installation.** For the maximum total equivalent flue length, please refer to the installation manual.*** The only systems approved for this application are: Marley muPVC (PVC-C) Solvent Weld Waste System (50mm), Polypipe System 2000 muPVC (PVC-C) Solvent Weld Waste System (50mm), Polypipe Terrain Solvent Weld System (50mm) and Wavin Osmo PVC-C Solvent Weld System (50mm). Please use the recommended Solvent Weld Cement for each system.

Specification Data

CENTRAL HEATING			S30
CH Output @ 70°C	Max	kW	30.3
	Min	kW	6.1
CH Output @ 40°C	Max	kW	31.0
	Min	kW	6.4
CH Input	Nett CV Max	kW	30.4
	Nett CV Min	kW	6.1
CH Input	Gross CV Max	kW	33.7
	Gross CV Min	kW	6.7
CH Gas Consumption	Max	m ³ /h	3.136
	Min	m ³ /h	0.623
OTHERS			S30
Seasonal Efficiency	SEDBUK 2005	%	91.1
	SEDBUK 2009/2012	%	89.6
Seasonal Space Heating Efficiency Class			A
NOx Classification			Class 6
GENERAL DATA			S30
Max Horizontal Flue Length	m	27 Flue / 2 Air	
Max Horizontal Flue Length (Parallel)	m	18 Flue / 18 Air	
Flue Terminal Diameter	mm	50	
Gas Supply		2H - G20 - 20mbar	
Gas Supply Connection		15mm copper compression	
Injector Size	mm	4.65	
Flow Connection (CH)		22mm copper compression	
Return Connection (CH)		22mm copper compression	
Average Flue Temp - Mass Flow Rate		69°C - 13g/s	
CO ₂ Content (±0.7) (Max CH)	%	9.6	
CO ₂ Content (±0.7) (Min CH)	%	8.7	
Max Working Pressure (Sealed Systems)	bar (psi)	2.5 (36.3)	
Electrical Supply		230V - 50Hz	
Power Consumption	W	102	
Fuse Rating		External 3A / Internal: T4A HRC L250V	
Water Content	l (gal)	1.2 (0.26)	
Weight (Packed)	kg	31.3	
Maximum Installation Weight	kg	27.3	

Example Flue Installation

Keston System 2 S30 - Flue & Air Pipe Length

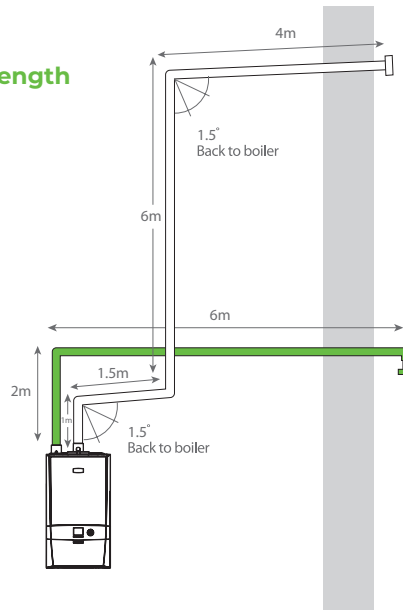
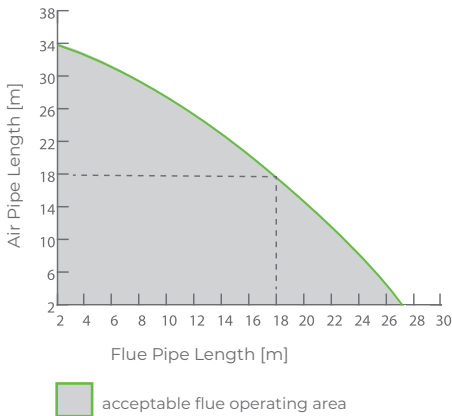

C53 HORIZONTAL

Calculations

Flue
 Elbows 3 x 1m = 3m
 Straights 4+6+1.5+1 = 12.5m
 Total = 15.5m

Air
 Elbows 2 x 1m = 2m
 Straights 6+2+0.1+1 = 8.1m
 Total = 10.1m

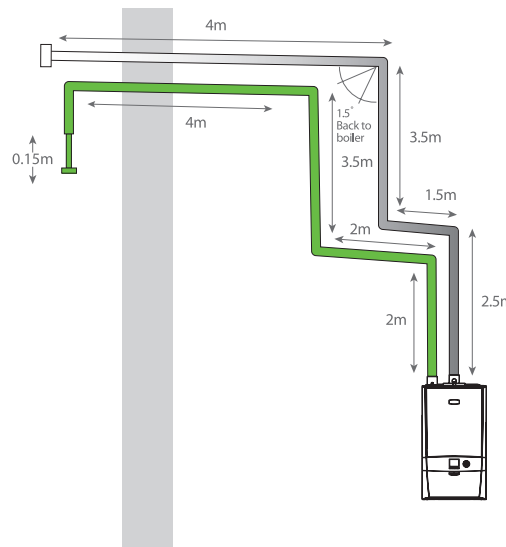

C13 HORIZONTAL

Calculations

Flue
 Elbows 3 x 1m = 3m
 Straights 4+3.5+1.5+2.5 = 11.5m
 Total = 14.5m

Air
 Elbows 4 x 1m = 4m
 Straights 2+2+3.5+4+0.15 = 11.65m
 Total = 15.65m

Dimensions

KESTON SYSTEM 2

Height	700mm
Width	395mm
Depth	278mm

The following minimum clearances must be maintained for operation and servicing.
 Front of boiler - 450mm[†]
 Sides of boiler - 2.5mm
 Above boiler - 350mm, with 30mm above the flue
 Below boiler - 100mm[†]

* Or equivalent length.

† Can be reduced to 5mm for cupboard fit, 450mm required for servicing.

Tel: 01482 443 005 Fax: 01482 467 133

Keston Heating, PO Box 103, National Avenue, Kingston Upon Hull HU5 4JN

keston.co.uk |     

**EXPERTS IN
HEATING**