

Mira Minimal Single & Dual Outlet Thermostatic Mixing Valve Installation and User Guide

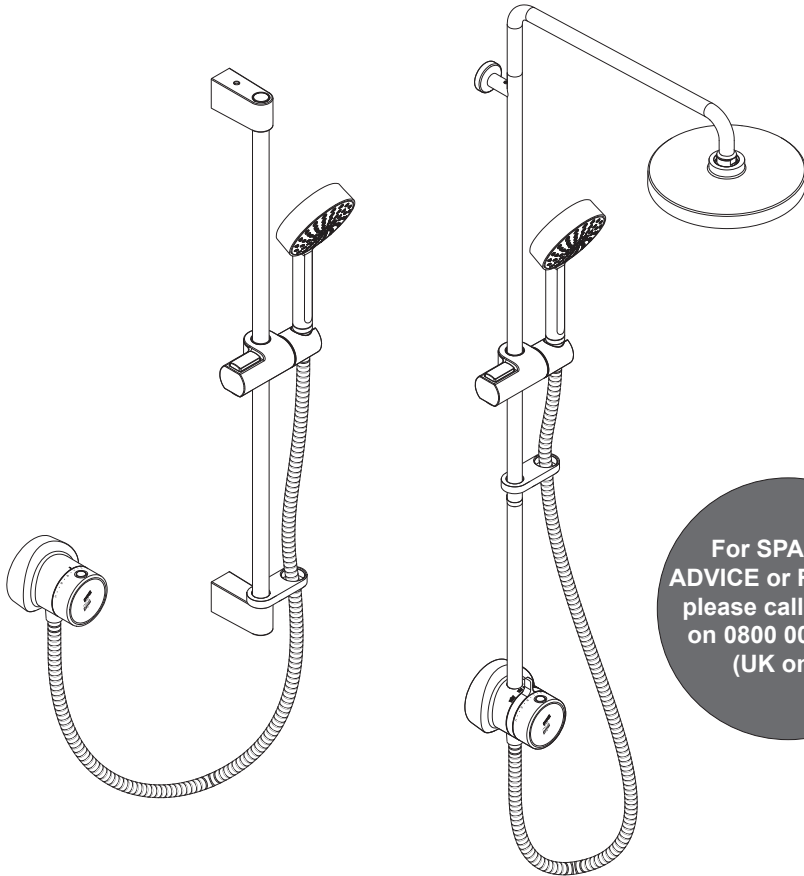

For SPARES,
ADVICE or REPAIRS
please call us free
on 0800 001 4040
(UK only)

These instructions must be left with the user

Model Name:
Product Code:
Date of Manufacture:

Affix Sticker Here

(Please keep these details safe as you will need them when registering your product guarantee. Your guarantee information is included in this guide.)



Introduction

Thank you for choosing a Mira shower. To enjoy the full potential of your new shower, please take time to read this guide thoroughly, and keep it handy for future reference. Products manufactured by Kohler Mira Ltd are designed to be safe, provided that they are installed, used, and maintained in good working order, in accordance with our instructions and recommendations.

Follow all warnings, cautions and instructions contained in this guide, and on, or inside the shower. This guide is also available in digital format from our website or by contacting customer services.

Type 2 Valves

This product has been certified as a Type 2 valve. It also complies with the Water Supply (water fittings) regulations 1999. For further information on Type 2 Valves, refer to the TMV2 Requirements Manual (available to view or download on our website www.mirashowers.com). The approved designation for this product is listed in the table below.

Mira Mixer Showers covered by this guide:

Product Code	Model Number	Colour	Type 2 Designation
B10A	Mira Minimal Single Spec	Chrome	HP-S
B10B	Mira Minimal Dual Spec		
B10Ar	Mira Minimal Single Retail		
B10Br	Mira Minimal Dual Retail		

Guarantee

For **domestic installations**, Mira Showers guarantee the product against any defect in materials or workmanship for a period of **five** years from the date of purchase (shower fittings for one year).

For **non-domestic installations**, Mira Showers guarantee the product against any defect in materials or workmanship for a period of **one** year from the date of purchase.

Failure to follow the instructions provided with the shower will invalidate the guarantee.

For Terms and Conditions refer to the '**Activating Your Free Guarantee and Customer Service**' pages.

Design Registration and Patents

Design Registration: GB 007749684-0001-0018

Recommended Usage

Domestic	✓	Heavy Commercial	✗
Light Commercial	✓	Healthcare	✗

Pack Contents

Minimal Single Outlet

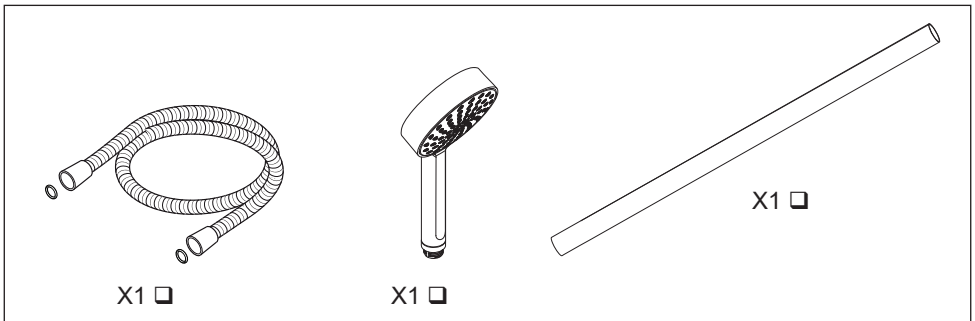
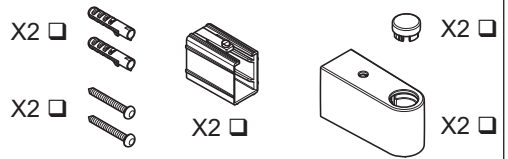
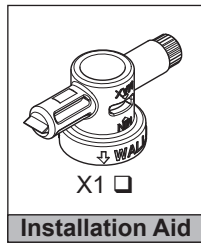
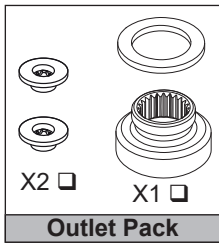
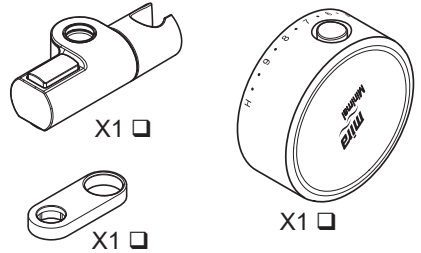
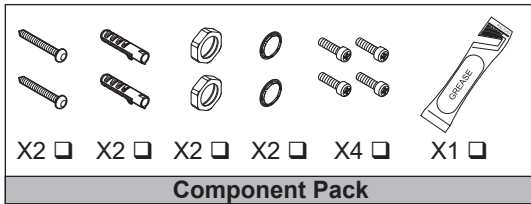
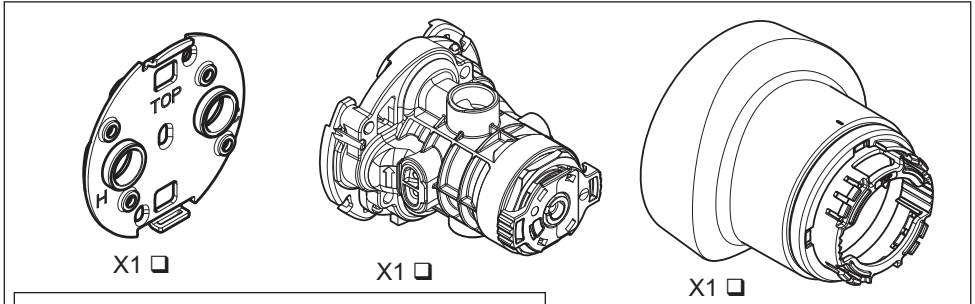
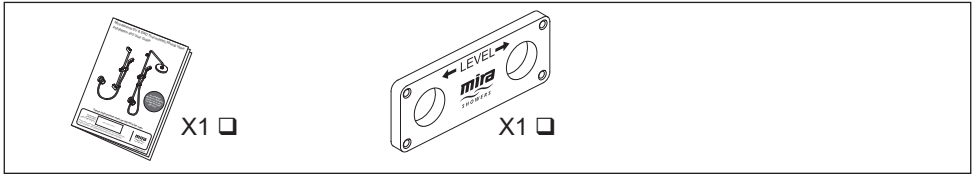

Minimal Dual Outlet

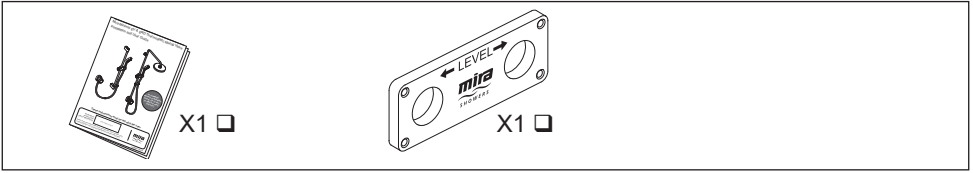

Note: Graphics and Riser Assembly may differ from images shown.

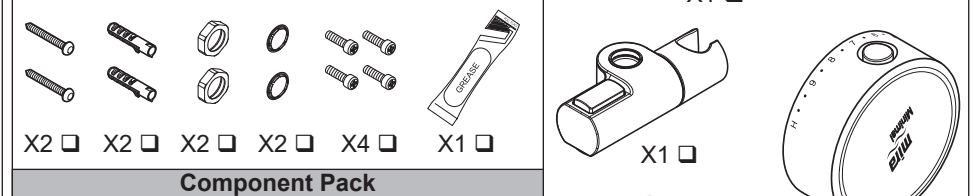
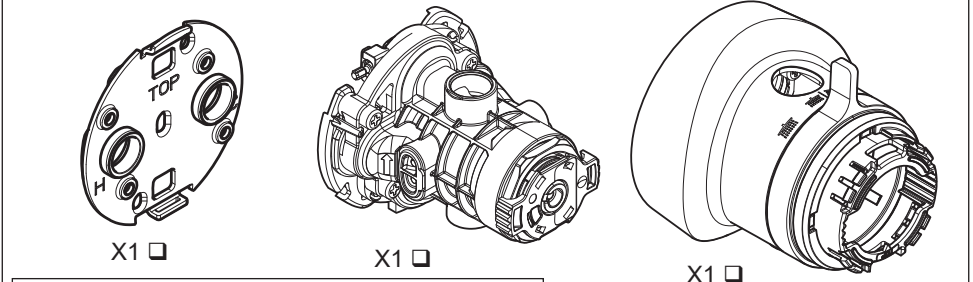

Component Pack



Outlet Pack

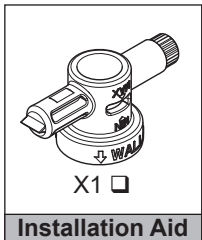

Installation Aid

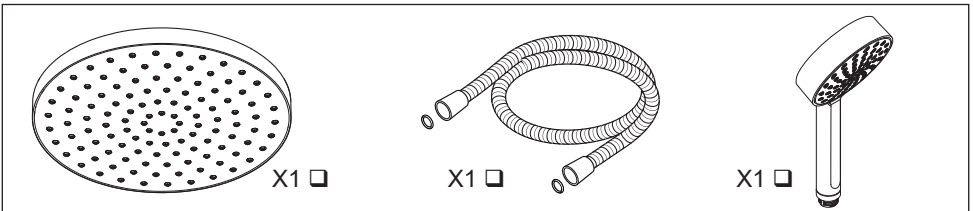
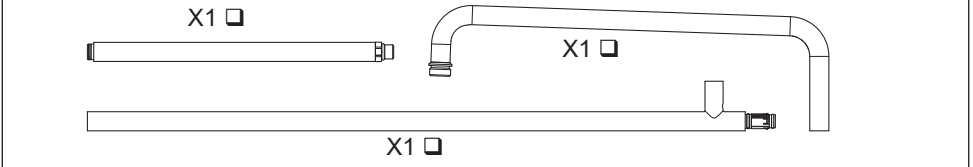
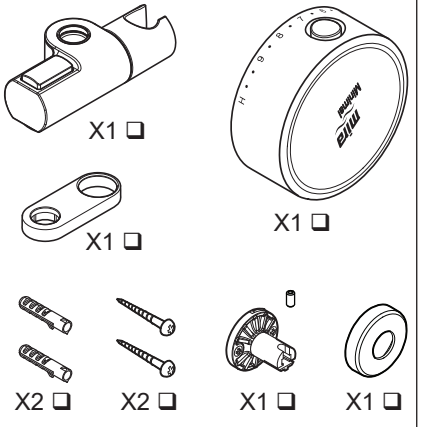

Safety Information

WARNING! This shower can deliver scalding temperatures. For continued safe operation, follow all instructions, warnings and cautions contained in this guide and on or inside the shower. Periodic maintenance may be required to keep the product in good working order.

The function of a thermostatic mixing valve is to deliver water consistently at a safe temperature. In keeping with every other mechanism, it cannot be considered as functionally infallible and as such, cannot totally replace a supervisor's vigilance where that is necessary. Provided it is installed, commissioned, operated, and maintained within manufacturers recommendations, the risk of failure, if not eliminated, is reduced to the minimum achievable.

PLEASE OBSERVE THE FOLLOWING TO REDUCE THE RISK OF INJURY:

Installing the Shower

1. Installation of the shower must be carried out in accordance with these instructions by qualified, competent personnel. Read all instructions before installing the shower.
2. **DO NOT** install the shower where it may be exposed to freezing conditions. Ensure that any pipework that could become frozen is properly insulated.
3. **DO NOT** perform any unspecified modifications to the shower or its accessories. When servicing only use genuine Kohler Mira replacement parts.
4. If the shower is dismantled during installation or servicing then, upon completion, an inspection must be made to ensure all connections are tight and that there are no leaks.

Using the Shower

5. The shower must be operated and maintained in accordance with the requirements of this guide. Make sure you fully understand how to operate the shower before use, read all instructions and retain this guide for future reference.

6. **DO NOT** switch the shower on if there is a possibility that the water in the shower unit or fittings is frozen.
7. The shower can be used by children aged from 8 years and above and persons with reduced physical, sensory, or mental capabilities or lack of experience and knowledge if they have been given supervision or instruction concerning use of the appliance in a safe way and understand the hazards involved. Children must not be allowed to play with the shower.
8. Anyone who may have difficulty understanding or operating the controls of any shower should be attended whilst showering. Particular consideration should be given to the young, the elderly, the infirm or anyone inexperienced in the correct operation of the controls.
9. **DO NOT** allow children to clean or perform any user maintenance to the shower unit without supervision.
10. Always check the water temperature is safe before entering the shower.
11. **DO NOT** adjust the temperature control rapidly while using the shower.
12. Use caution when altering the water temperature while in use, always check the temperature before continuing to shower.
13. **DO NOT** switch the shower off and back on while standing in the water flow.
14. **DO NOT** fit any form of outlet flow control. Only Mira recommended outlet fittings should be used.
15. The showerhead must be descaled regularly. Any blockage of the showerhead or hose may affect showering performance.
16. The water supplies to this product must be isolated if the product is not to be used for a long period of time. If the product or pipework is at risk of freezing during this period they should also be drained of water.
17. When this product has reached the end of its serviceable life, it should be disposed of in a safe manner, in accordance with current local authority recycling, or waste disposal policy.

Specifications

Pressures	
Maximum Static Pressure	1000 kPa (10 bar)
Maximum Maintained Pressure	500 kPa (5 bar)
Minimum Maintained Pressure (Gas Water Heater)	100 kPa (1 bar) (for optimum performance supplies should be nominally equal)
Minimum Maintained Pressure (Gravity System)	10 kPa (0.1 bar) (0.1 bar = 1 Metre head from cold tank base to shower handset outlet)
Temperatures	
Close temperature control	20°C - 50°C
Optimum Thermostatic Control Range	35°C to 45°C (achieved with supplies of 15°C cold, 65°C hot and nominally equal pressures)
Recommended Hot Supply	60°C to 65°C
Minimum Hot Water Supply Temperature	55°C (Note: The mixing valve can operate at temperatures up to 85°C for short periods without damage. However for safety reasons it is recommended that the maximum hot water temperature is limited to 65°C).
Minimum Recommended Differential between Hot Supply and Outlet Temperature	12°C at desired flow rates
Cold Water Range	1 - 25°C
Plumbing Connections	
Hot: Left	15mm copper pipework
Cold: Right	15mm copper pipework
Outlet:	Single Outlet = 1/2" BSP Male to flexible house Dual Outlet = 1/2" BSP Male to flexible hose and push fit to Riser bar.

- **Important!** This product is not suitable to use with any other pipe sizes.
- **Warning!** This product does not allow for reversed inlets and will deliver dangerously unstable temperatures if fitted incorrectly.

Thermostatic Shut-down

- For safety and comfort the thermostat will shut off the mixing valve **within 2 Seconds** if either supply fails (achieved only if the blend temperature has a minimum differential of 12°C from either supply temperature).

Suitable Plumbing Installations

The Thermostatic Mixer can be installed with all systems with balanced pressures. Mixed gravity and mains supplies are not recommended.

Installation

Warning! This product does not allow for reversed inlets and will deliver unstable temperatures if fitted incorrectly.

General

1. Installation of the shower must be carried out in accordance with these instructions by qualified, competent personnel.
2. The plumbing installation must comply with all national or local water regulations and all relevant building regulations, or any particular regulation or practice specified by the local water supply company.
3. Make sure all pressures and temperatures comply with the requirements of the shower. See '*Specifications*'.
4. Full bore/non restrictive servicing valves must be fitted in a readily accessible position adjacent to the shower to facilitate maintenance of the shower.
DO NOT use a valve with a loose washer plate (jumper) as this can lead to a build up of static pressure.
5. **DO NOT** apply excessive force to plumbing connections; always provide mechanical support when making plumbing connections. Any soldered joints should be made before connecting the shower.
6. Pipework dead-legs should be kept to a minimum.
7. **DO NOT** install the shower unit in a position where access for maintenance is restricted.
8. The shower must be fitted to a waterproof, flat and even wall surface. The two screws and wall plugs supplied are suitable for most solid wall installations. Alternative fixing screws for panel structures are not supplied. Use both fixing points to secure the shower, be sure to use fixings appropriate for the chosen wall structure.
9. When pipework enters the product from the rear through a hole in the wall, provision must be made to prevent water ingress back into the wall structure.
10. Position the shower unit where the controls are at a convenient height for the user. Position the showerhead so that the water sprays in line with the bath or across the opening of a shower cubicle. The installation must not cause the shower hose to be kinked during normal use.

11. The water supplies to this product should be isolated if the product is not to be used for a long period of time. If the product or pipework is at risk of freezing during this period they should also be drained of water.
12. The position of the shower and shower fittings must provide a minimum air gap of 25 mm between the showerhead and the spill over level of any bath, shower tray or basin. There must be a minimum distance of 30 mm between the showerhead and the spill over lever of any toilet, bidet or other appliance with a Fluid Category 5 backflow risk.

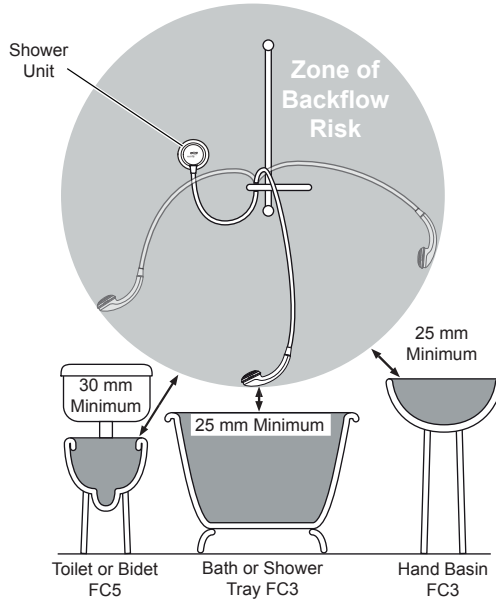

Note: There will be occasions when the hose retaining ring will not provide a suitable solution for Fluid Category 3 installations. In these instances an outlet double checkvalve must be fitted, this will increase the required supply pressure typically by 10kPa (0.1 bar). Double checkvalves fitted in the inlet supply to the appliance cause a pressure build up, which affects the maximum static inlet pressure for the appliance and must not be fitted. For Fluid Category 5, double checkvalves are not suitable.

Shower Positioning

The shower fittings should be positioned at a convenient height for all the family. Position the fittings to spray across rather than towards the opening of the cubicle and also away from the shower control. Avoid layouts where the shower hose will be sharply kinked. This may reduce the life of the hose.

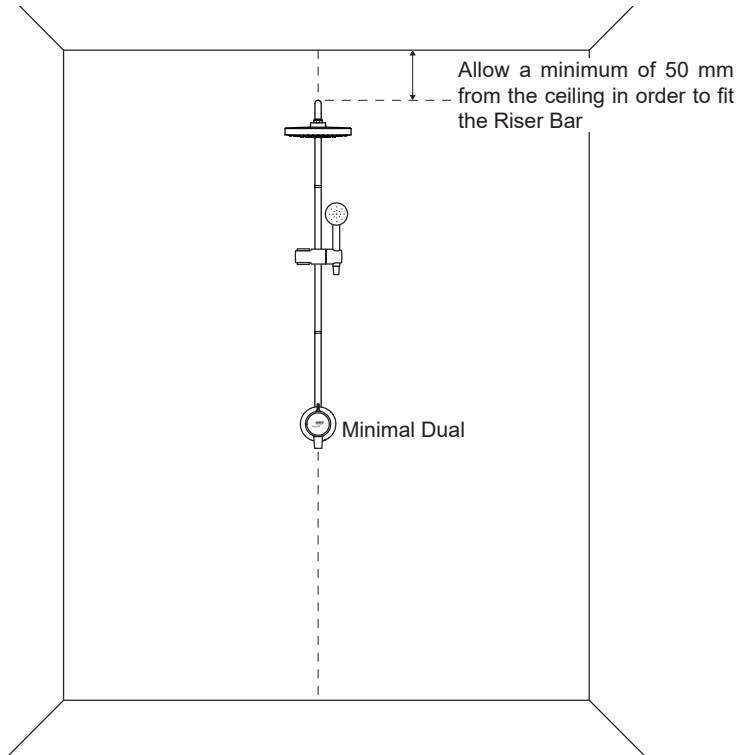

Note: If installing in a restricted height area a short bar can be ordered as a spare part.



Critical! The installation area must be carefully prepared and all tiles cut or drilled accurately for a successful installation.

Note: This product DOES NOT allow for reversed inlets and will deliver dangerously unstable temperatures if fitted incorrectly. If the tile cutting area exceeds the boundaries, the wall plate may not conceal drilled holes.

Installation

1 General

a

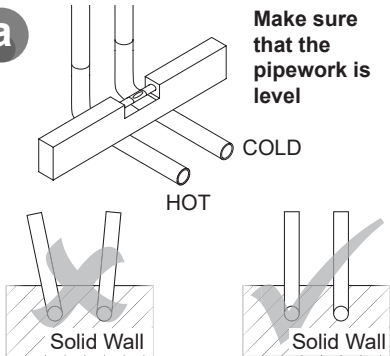

Pipe work installation viewed from above.

Pipework must be at 50 mm centres, level and perpendicular to the finished wall surface.

It is recommended that the pipework is secure but not rigidly fixed at this stage, in case of further adjustment when the retaining wall plate is fitted.

Only use $\varnothing 15$ mm copper pipe for connection to the valve.

DO NOT use any other pipe sizes.

b

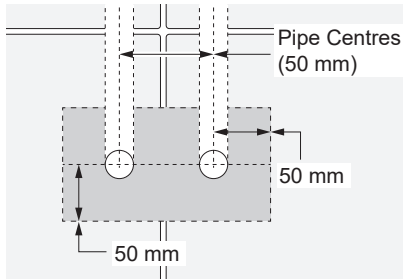

Ensure you have enough pipework through the wall to allow it to be cut to the specified length when wall is finished (A minimum of 150 mm is recommended).

The drill holes for the central fitting of the wall plate screws must be into brick, wooden noggin or similar sound wall structure. We recommend the sound wall structure should extend to an area approximately 50 mm around the pipe centres.

2 For Stud Partition Walls

a

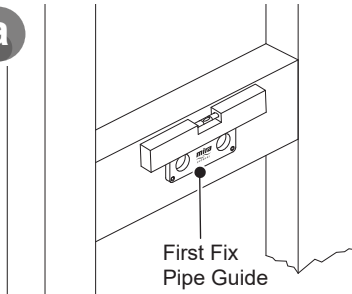

For stud partition wall installations, make sure that a wooden noggin is in place directly behind the final valve position.

The supplied First Fix Pipe Guide **MUST** be used to mark the pipework centres, check that the pipe guide is level and mark the pipework centres.

DO NOT drill through the pipe guide.

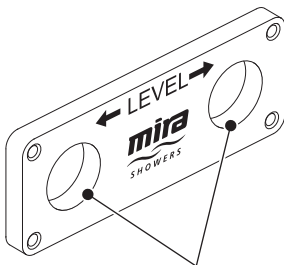

b

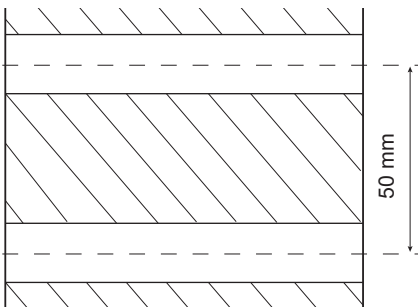

TOP VIEW

Make sure the holes drilled through the noggin are square and level to the mounting surface.

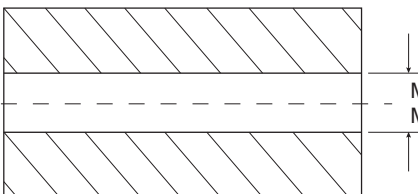

SIDE VIEW

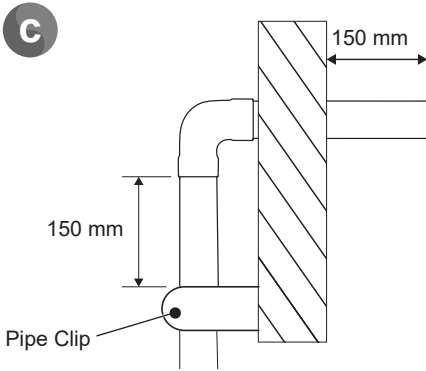

Plumb supplies using 15 mm copper pipework, make sure a minimum 150 mm of pipe extends from the front surface of the noggin (to ensure the required minimum length to fit the product).

We recommend the use of a pipe clip to secure the pipework within the wall, this **MUST** be placed a minimum of 150 mm from the elbow joint.

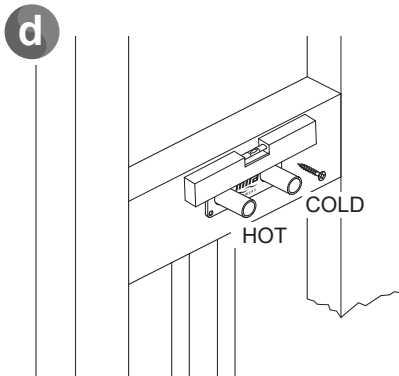

Once the pipework is in place, slide the First Fix Pipe Guide over the protruding pipework.

Important! At this stage re-check the pipework is square and level*.

Mark and drill the pipe guide fixing holes then attach directly to the noggin. This can remain within the wall.



LEVEL



LEVEL

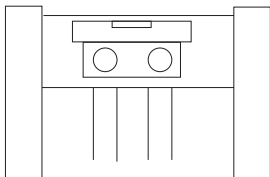

* Pipework that is not level will make final assembly of the valve very difficult

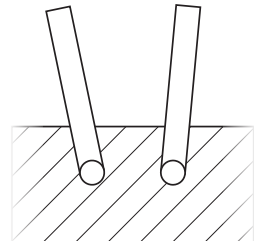
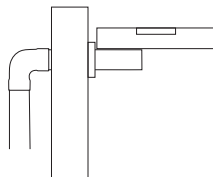

Pipe work installation viewed from above.

Installation of Mixing Valve

1

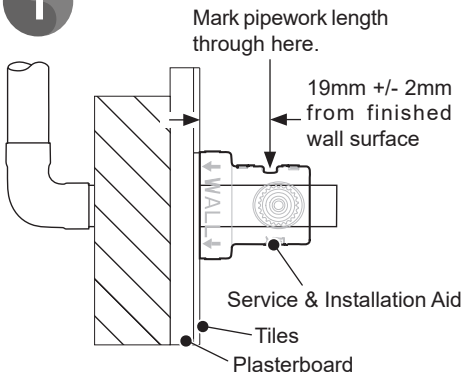

Place the service & installation aid over each pipe and using the cut out, mark the pipe for optimal length and cut pipe using a pipe slice.

DO NOT use a hacksaw as the sharp edges may damage the seals in the mixer valve.

Note: De-burr the pipework if necessary.



Hacksaw



Pipe Slice



Service & Installation Aid

Note: Ensure installation aid is against the finished wall surface.

2

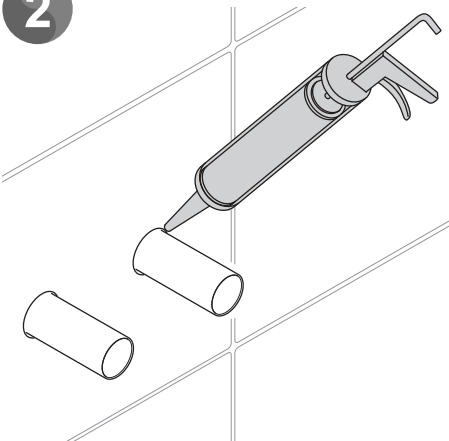

Apply silicone sealant according to the manufacturers instructions to the pipework where it comes through the wall.

Ensure silicone is applied carefully to avoid any further movement of pipes.

Allow the silicone sealant to cure for few hours before further installation.

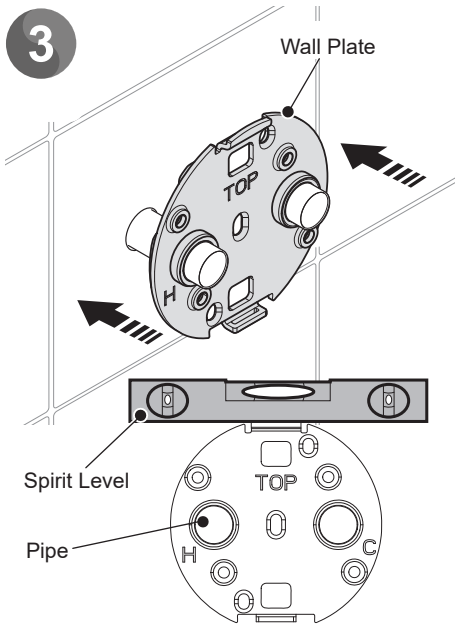

Fit the wall plate over the pipes ensuring that they do not push back into the wall.

Note: Identification on the wall plate shows the orientation that the plate must be fixed to the wall.

Note: There are three positions to screw the plate to the wall, only two should be used. The most ideal installation is to use the top and bottom holes but depending on the installation the centre hole can be used.

Pick and mark two of the most suitable holes and remove the wall plate from the pipes.

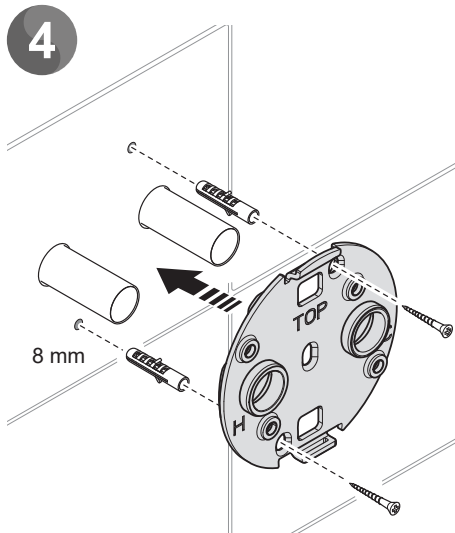

Drill the two 8mm holes and insert the wall plugs.

Caution! DO NOT drill into cables or pipes in the wall.
DO NOT drill through the wall plate on the wall.

Using the fixing screws provided, secure the wall plate to the wall. The use of incorrect screws may cause leaking when the mixer valve fitted.

Note: Use the provided screws only.

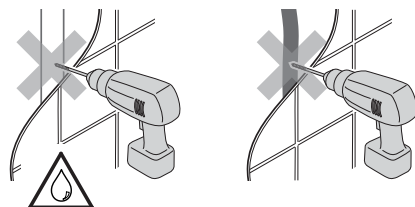

5

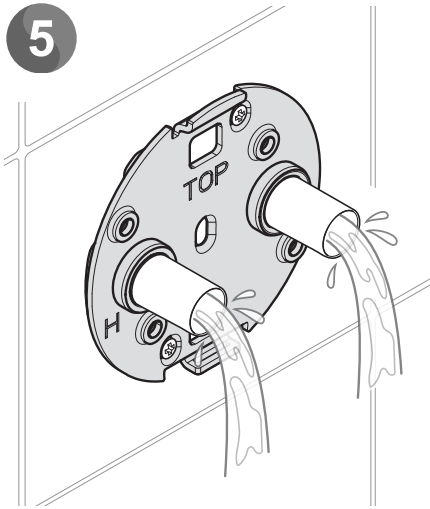

Flush the water supplies thoroughly before connecting the valve.

In retrofit installations (where you are replacing an old AGILE valve), if filters are present in the pipework, then please remove them.

6

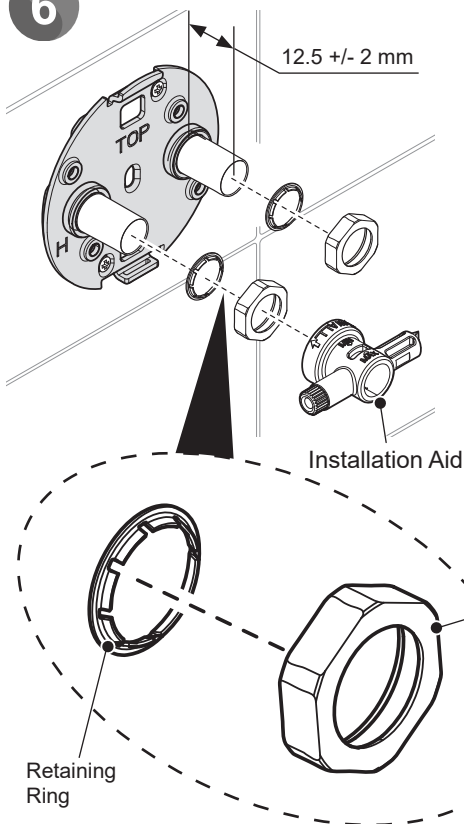

Place the retaining rings and nuts over the pipes in the orientation shown and tighten in place using the installation aid.

Note: Make sure the pipes are protruding through the wall plate to the correct length (12.5 +/- 2 mm).

Note: Only hand tighten the nuts using the installation aid.

Important! The retaining ring and nut **MUST** be fitted to ensure the pipework is secure and that the product doesn't leak.

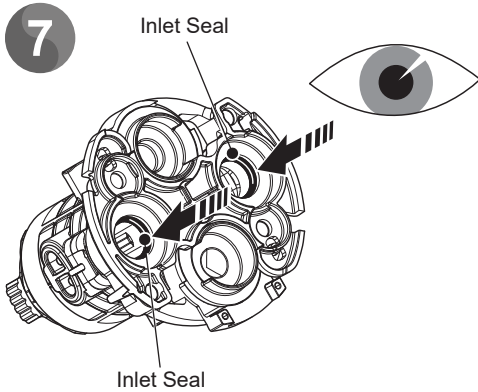

Important! Check cleanliness of inlet seals.

Apply a small amount of grease from the pack supplied to the two inlet seals. You will need the remaining grease at later stage.

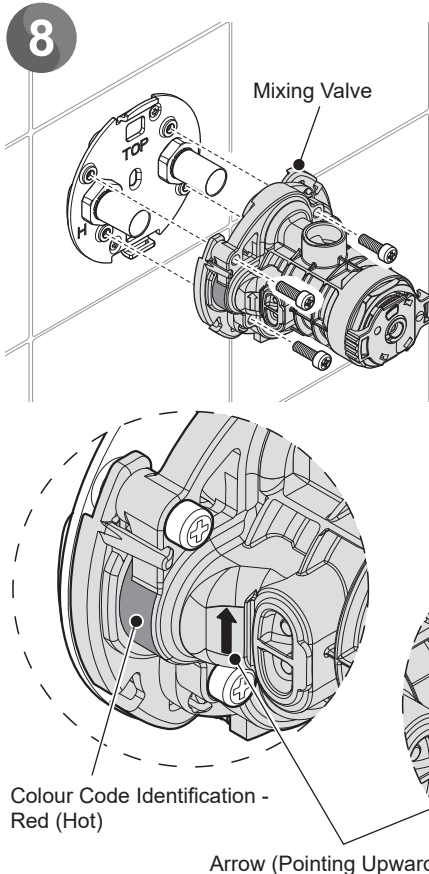

Check pipes are de-burred correctly.

Install the valve on the wall plate using the four bolts (supplied).

Note: The Valve is colour coded in the area shown below. RED for HOT and BLUE for COLD. These must match the H and the C that are marked on the wall plate.

Note: Make sure the arrows on the valve body are pointing in upward direction.

If installing the single showerhead product, continue steps 9 to 12.

If installing the dual showerhead product, continue to step 13.

Single Outlet Fittings

9

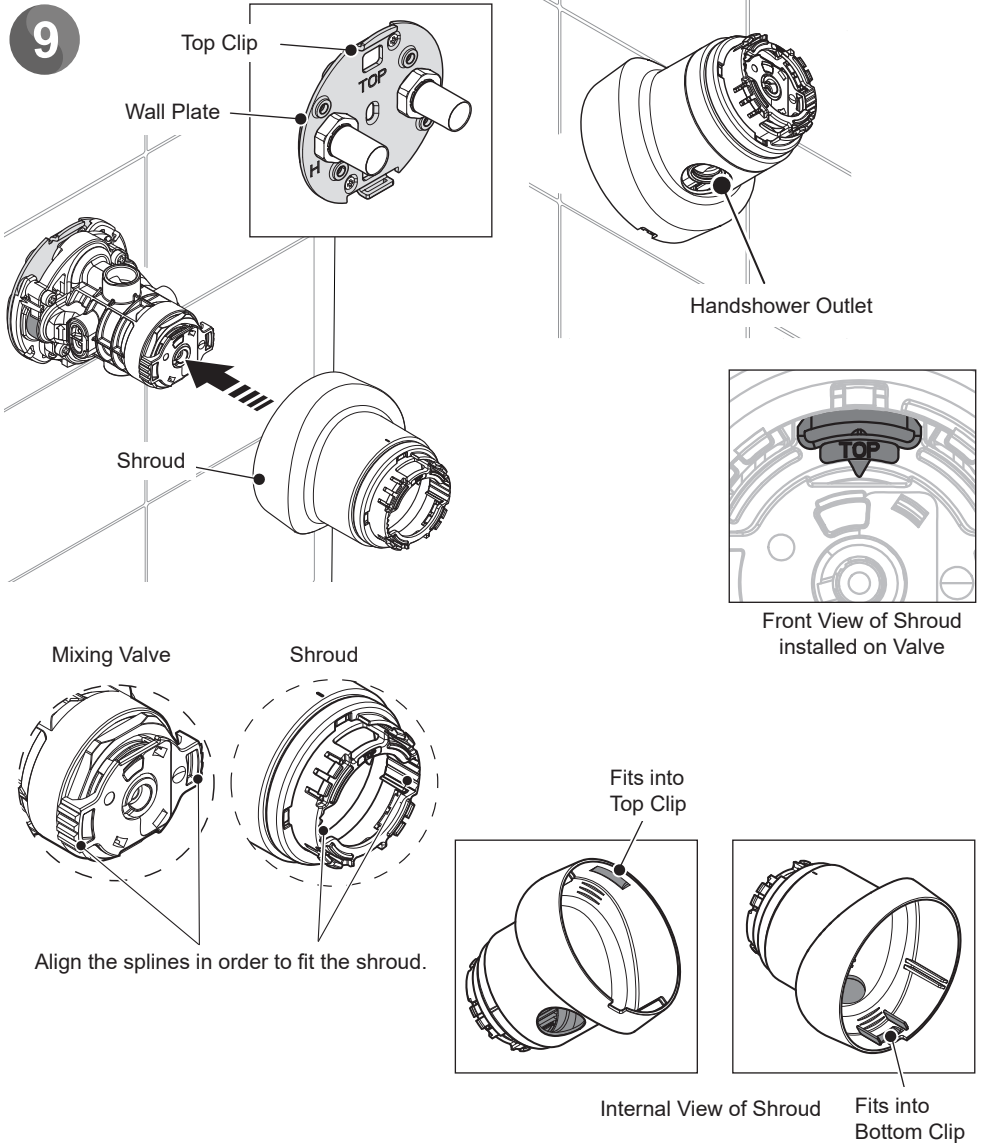

Note: Ensure that the spline is oriented in line as shown above.

Slide the shroud over the valve until shroud touches the clips, ensure outlets are in the correct position and drive features match. The shroud should click and clip into place.

Pull the shroud gently and wobble to ensure its clipped into place.

10

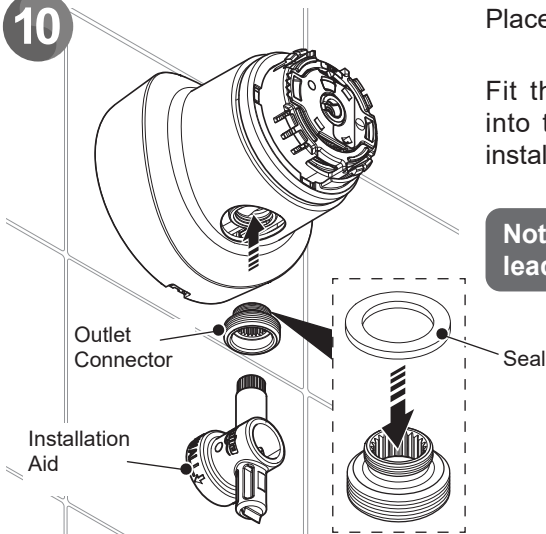

Place the seal onto the outlet connector.

Fit the outlet connector with the seal into the bottom of the valve using the installation aid provided.

Note: DO NOT overtighten as this can lead to damage to outlet connector.

11

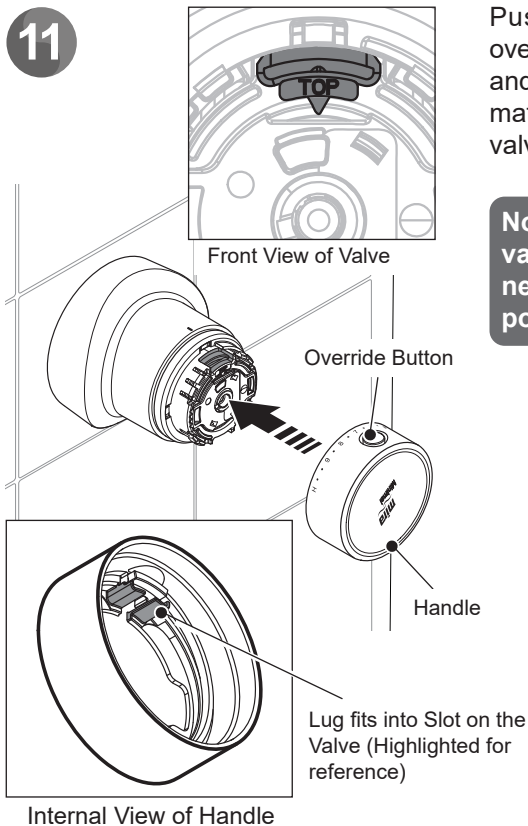

Push fit the handle ensuring that the override button is set at 12 O'clock position and the lug on the inside of the handle matches up with the slot available on the valve.

Note: Position of "TOP" area on the valve may not be facing upwards and needs to be manually rotated into the position shown.

12

Installation of Single Outlet Shower Fitting

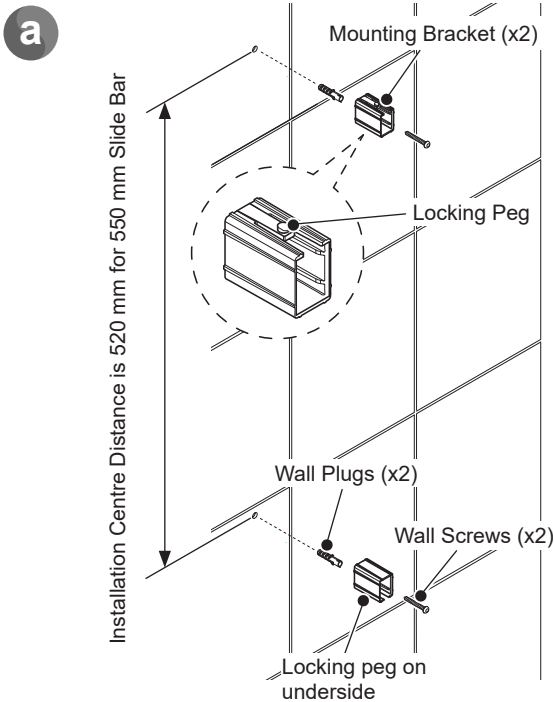

Mark the wall fixing positions and drill two holes to suit the wall fixings.

Caution! Do not drill into cables or pipes in the wall.

Note: Installation fixing centres are 520 mm for the 550 mm slide bar.

Install the wall plugs and the mounting brackets and secure with the wall screws.

Note: Ensure locking peg orientated correctly.

Note: Check for vertical alignment before tightening. The mounting brackets are slotted to aid this alignment. Then fully tighten.

Install the clamp bracket, the hose retaining ring (smallest hole) and the slide bar supports to the slide bar.

Note: Orientate hole in line with locking peg on mounting bracket.

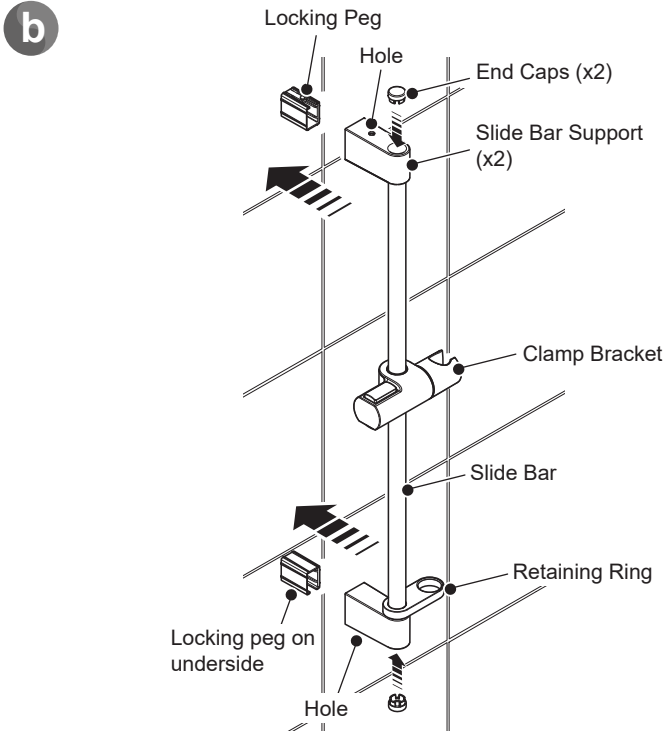

Ensure an equal length of slide bar protrudes from the top and bottom slide bar support (or flush with the end of the slide bar for new installations) and push onto mounting bracket. Ensure it clicks into place.

Caution! DO NOT force assembly on to the mounting brackets, re-align slide bar support if required.

Warning! Ensure that the locking peg clicks in and is fully engaged in the hole in the slide bar support.

Install the end caps, push fit into both ends of the slide bar.

Note: Slide bar support removal. Using a suitable tool, push and hold down the locking peg through the hole in the slide bar support and pull off.

C

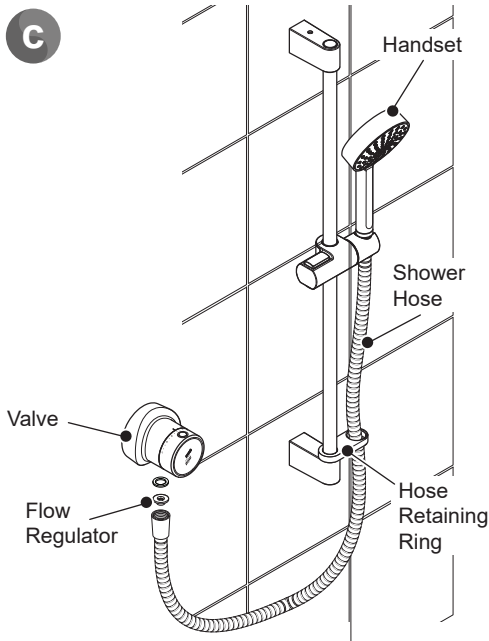

Information for Flow Regulators:

For maintained (running) water pressure greater than 0.5 bar, installing a flow regulator can help to reduce:

- Excessive shower force
- Noise due to high or unequal water pressure
- Unstable supply temperature
- Cooler outlet temperatures due to the colder seasons

Hose and Showerhead Installation

Fit a hose seal into the conical nut and screw onto the outlet of the valve. (Install the flow regulator if required).

Caution! DO NOT over tighten.

Feed the hose through the hose retaining ring.

Fit a hose seal into the conical nut and screw onto the showerhead.

Caution! DO NOT over tighten.

Place the showerhead assembly into the clamp bracket assembly.

Only use the supplied handset with this product.

Clamp Bracket Adjustment

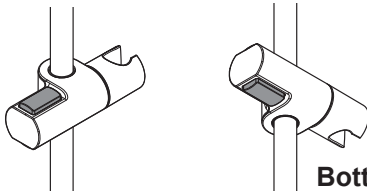

Bottom View

Press the two buttons on the clamp bracket to adjust the position.

Warning! Slide bar must not be used as a grab rail.

At this stage, continue directly to the **Commissioning Section** if installing a single outlet product.

Dual Outlet Fittings

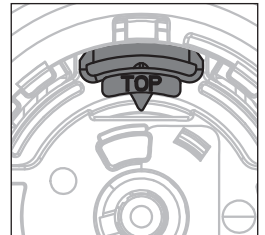
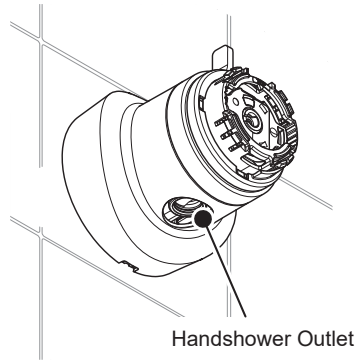
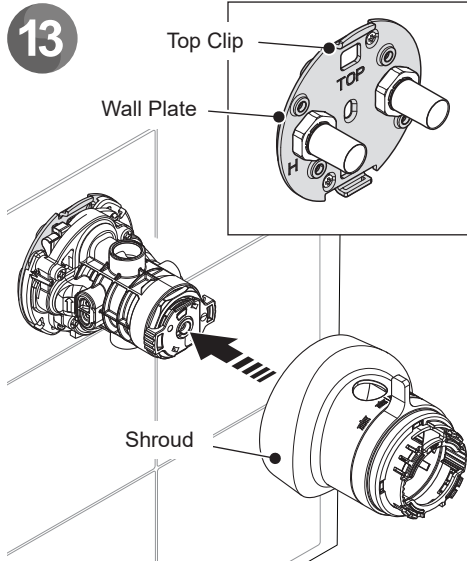

Front View of Shroud installed on Valve

Mixing Valve

Shroud

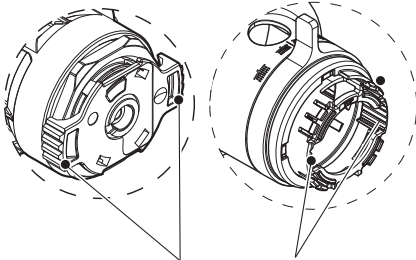

Align the splines in order to fit the shroud.

Fits into Top Clip

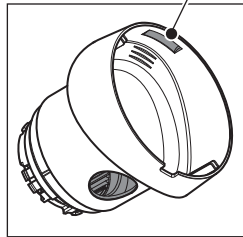

Internal View of Shroud

Fits into Bottom Clip

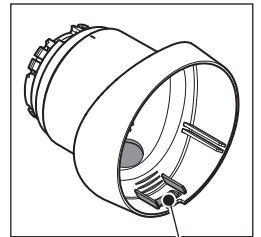

Note: Ensure that the spline is oriented in line as shown above.

Slide the shroud over the valve until shroud touches the clips, ensure outlets are in the correct position and drive features match. The shroud should click and clip into place.

Pull the shroud gently and wobble to ensure its clipped into place.

14

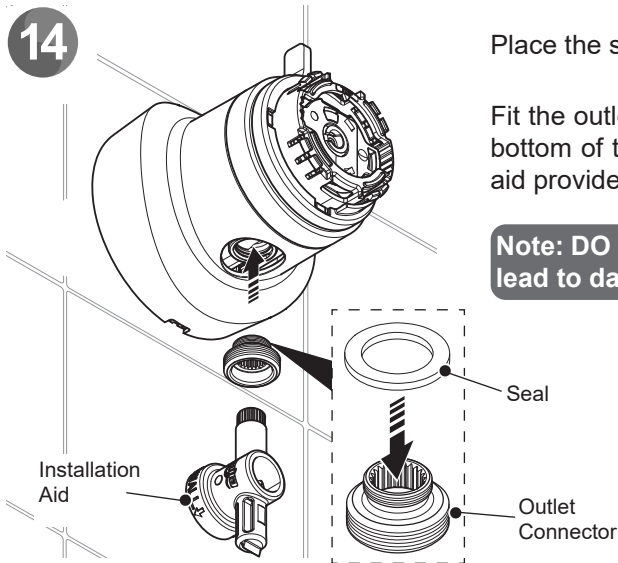

Place the seal onto the outlet connector.

Fit the outlet connector with seal into the bottom of the valve using the installation aid provided.

Note: DO NOT overtighten as this can lead to damage to outlet connector.

15

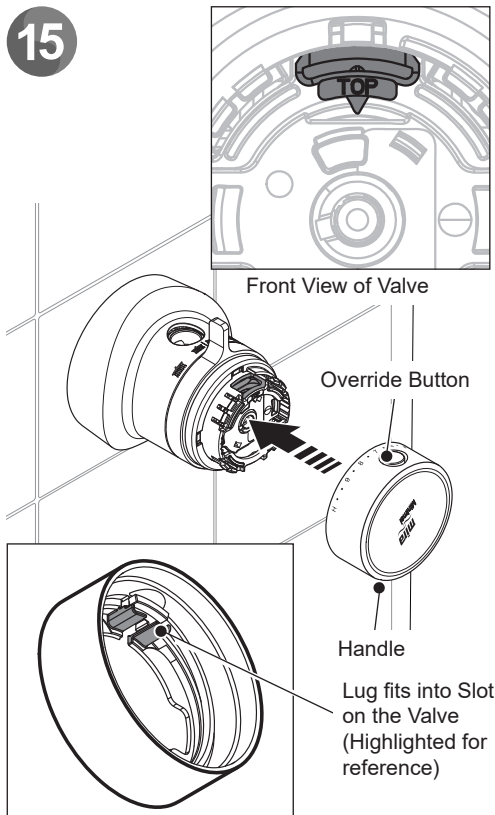

Push fit the handle ensuring that the override button is set at 12 O'clock position and the lug on the inside of the handle matches up with the slot available on the valve.

Note: Position of "TOP" area on the valve may not be facing upwards and needs to be manually rotated into the position shown.

Note: Should the shroud need to be removed to realign components, firstly remove the outlet connector, then apply pressure to the sides of the shroud, try to slide shroud down and away from the wall until the bottom clip is disengaged. Then, still applying pressure to the sides, slide the shroud up to remove from the clip. (see Maintenance Section for further information)

16 Installation of Dual Outlet Shower Fitting (Spec)

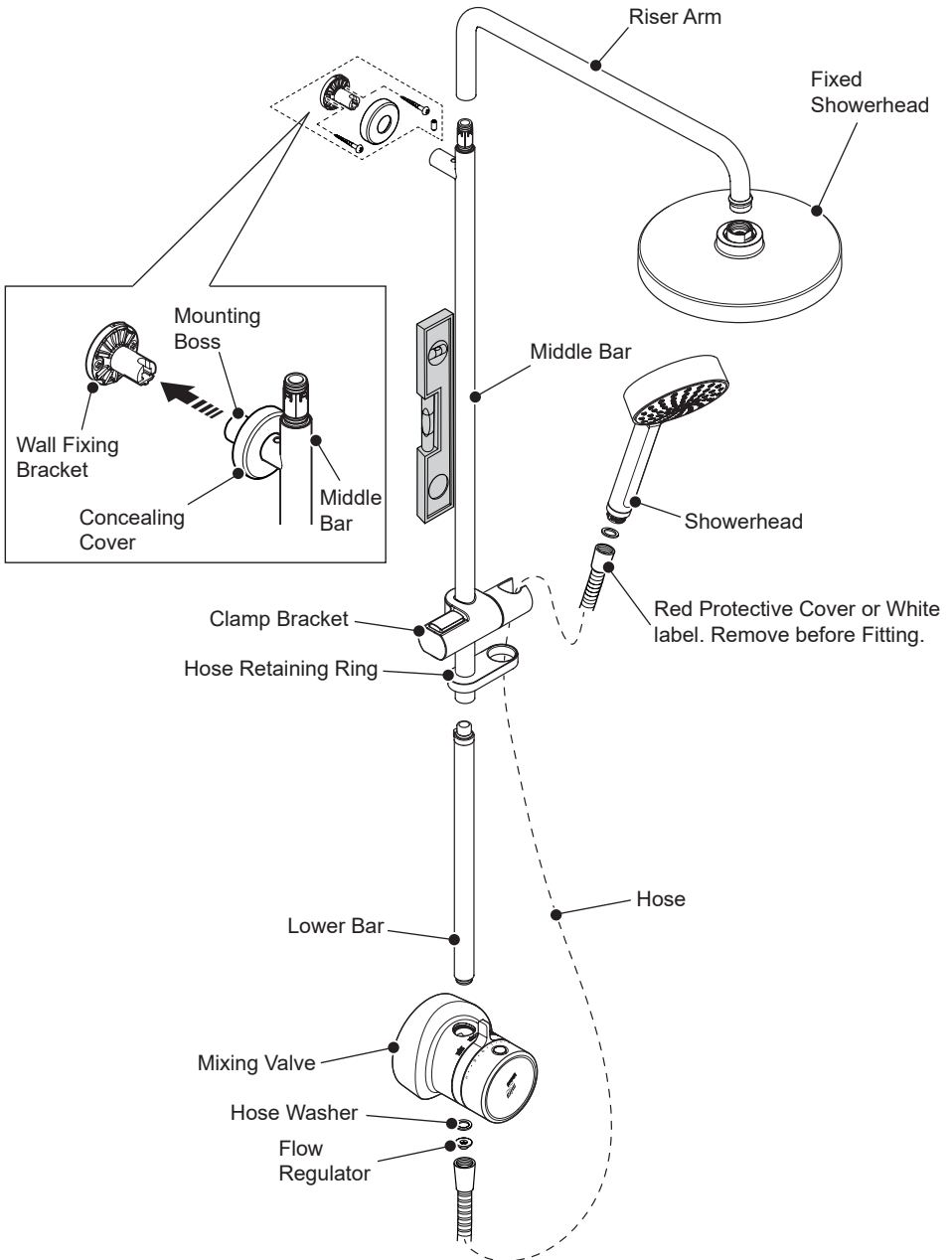

Installation of Dual Outlet Shower Fitting (Retail)

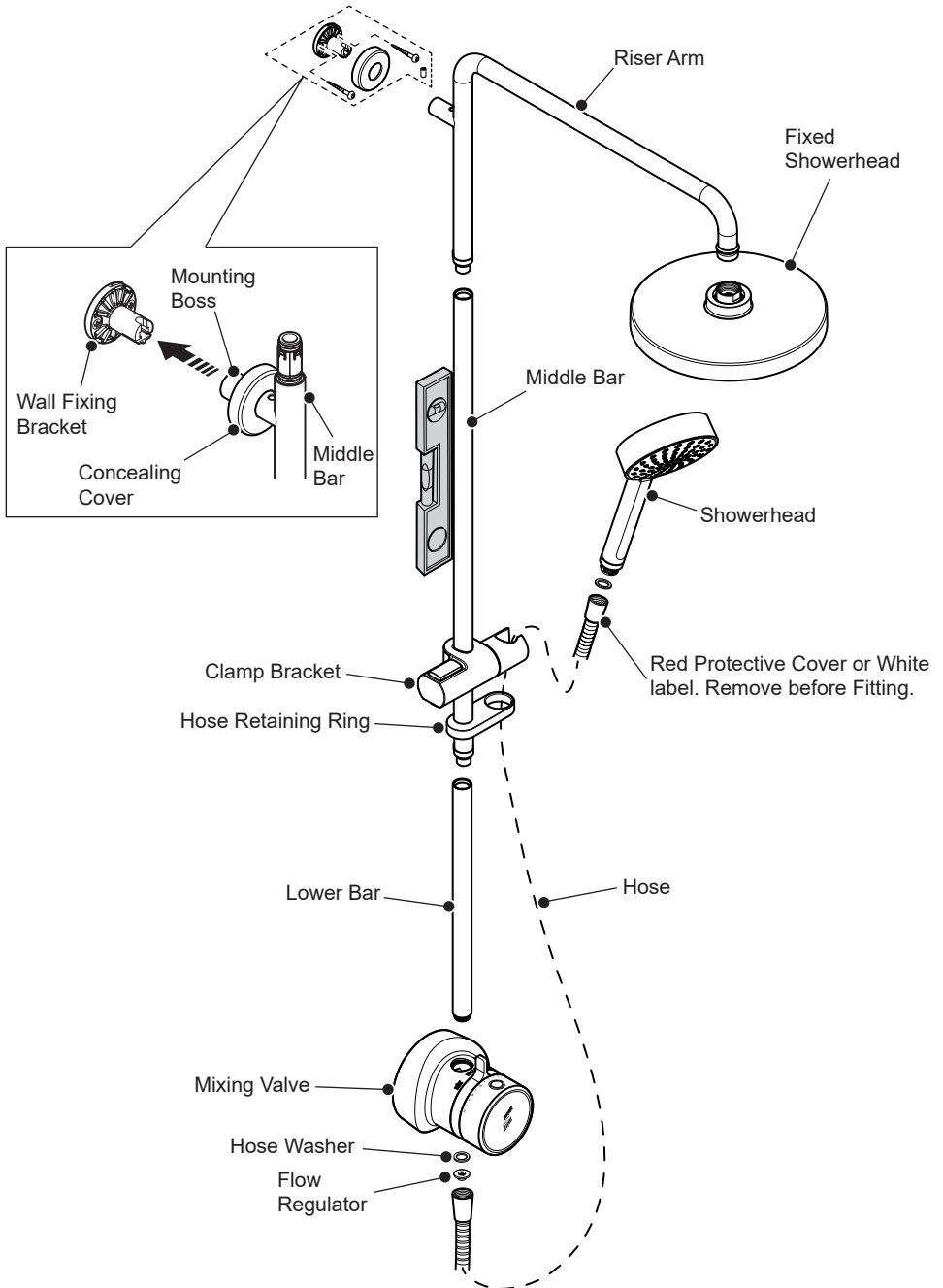

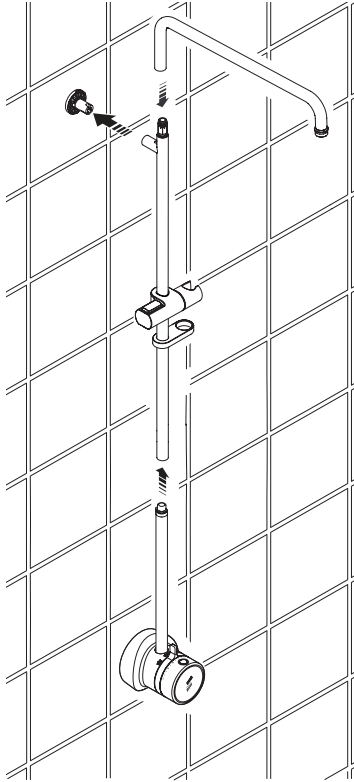
a

Slide the clamp bracket and hose retaining ring onto the middle bar, and then screw the middle and lower bar sections together. Push fit the riser arm to the middle and lower bar section.

Apply a small amount of grease to the two seals to aid installation.

Push the lower bar fully into the top of the mixing valve.

Note: The lower bar must be located correctly, push down firmly to seat it.

Insert the wall fixing bracket into the middle arm mounting boss, then swivel the bar if necessary to reposition the wall fixing bracket against the wall.

Note: The grubscrew mounting hole must be positioned at the top.

Mark the holes for the wall fixing bracket.

Note: Use a spirit level to ensure the bar is vertical.

Remove the wall fixing bracket from the mounting boss then remove the lower bar from the mixing valve.

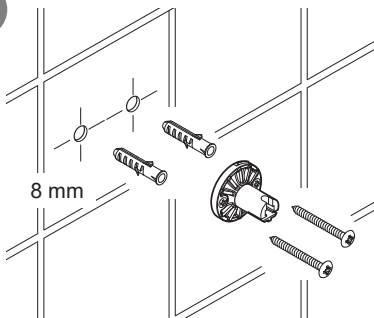
b

Note: When drilling the tiles ensure this is done in the middle or towards the bottom of the marked slots.

Drill two holes to suit the wall fixings, ensuring that the valve is protected from debris. Fix the bracket to the wall.

A small amount of silicone sealant in the wall bracket slots either side of the screw will help prevent abnormal movement of the middle bar.

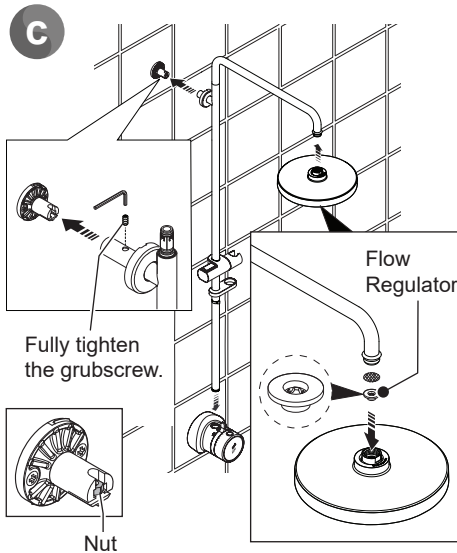

Refit the lower bar into the mixing valve and then put the concealing cover onto the riser arm mounting boss.

Ensure the nut is located correctly then push the riser arm mounting boss onto the wall fixing bracket.

Fit and tighten the grubscrew using a 2.5mm hexagonal key into the hole on top of the mounting boss (see illustration).

Make sure the screw is fully tightened and ensure the riser pipe is completely secured to the wall fixing bracket.

Fit the concealing cover into place.

Screw the fixed shower head onto the riser rail. (Install the flow regulator if required).

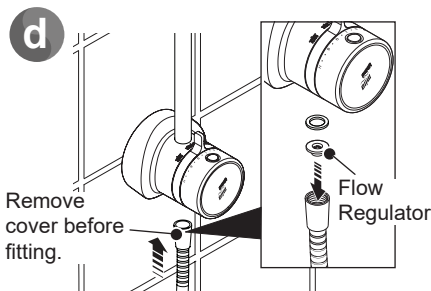

Fit the shower hose onto the bottom outlet of the mixing valve. (Install the flow regulator if required).

Information for Flow Regulators:

For maintained (running) water pressure greater than 0.5 bar, installing a flow regulator can help to reduce:

- Excessive shower force
- Noise due to high or unequal water pressure
- Unstable supply temperature
- Cooler outlet temperatures due to the colder seasons

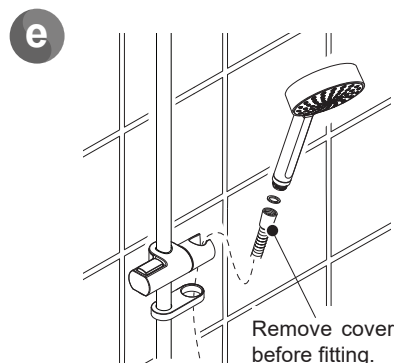

Push the shower hose through the retaining ring and screw it to the showerhead.

Place the showerhead into the clamp bracket, adjusting the angle and height to the users preference.

Warning! Slide bar must not be used as a grab rail.

Commissioning



Before turning water back ON, ensure the product is in the OFF position. Turn product fully anticlockwise, then turn the water back ON.

Maximum Temperature Setting

Before using the shower, the maximum temperature must be checked to make sure that it is at a safe level. It has been preset to a safe showering temperature under ideal conditions at the factory, appropriate for most systems. However, site conditions and personal preference may make it necessary to reset this temperature.

Note: Make sure that the hot water temperature is at least 55°C and that there is sufficient supply.

Caution! Before making any adjustments to the shower, operate the temp control from max hot to cold and make sure hot and cold water flows correctly from the shower outlet. After making any adjustments repeat this process.

1. Turn the temperature handle **clockwise** until it stops and test that the temperature of the water from the shower outlet is hot enough.
2. If not, depress the override button and **carefully** rotate the handle further. If the water temperature is still not hot enough complete the following procedure.
3. Rotate the temperature selector handle back to the override position.
4. Remove the handle by using the blade on the Installation aid, place in between the bottom of the handle and the shroud and twist to unclip the handle.

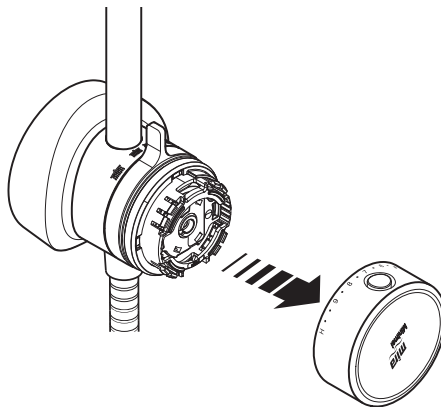
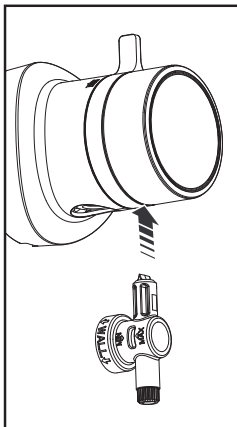

5. Remove the maximum temperature peg from the top of the valve by using a screwdriver. Refit the handle.

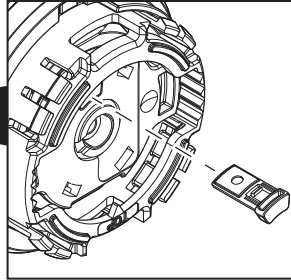
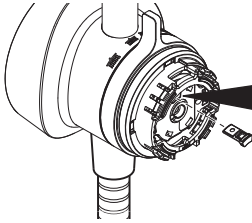

Note: Maximum temperature achievable is 49°C.

Operation

The dual outlet product has outlet selector to choose the desired outlet. User can individually choose the handshower or overhead by rotating the outlet selector.

Important! Read the 'Safety Information' before using your shower.

Note: When diverting from showerhead to overhead a small amount of cold water may initially flow.

Important! DO NOT allow the overhead or handset spray water directly on to the mixing valve. The overhead and handset must be positioned so this does not occur.

On/Off and Temperature Control

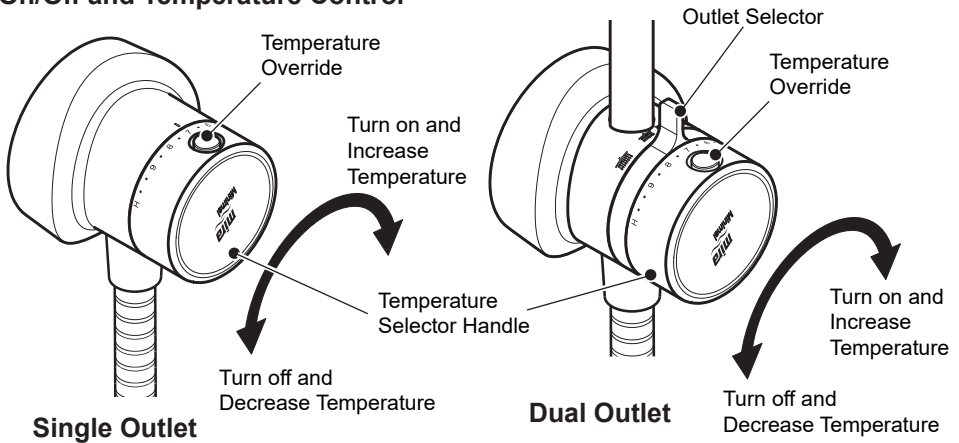

The product turns on as well as adjust the temperature by rotating the temperature handle in clockwise direction. Operate the shower and make sure it delivers cold water initially and then further rotate to increase temperature, for safety reasons, the temperature is limited by an override stop button. To obtain a higher temperature, press the override button on the temperature handle and continue to rotate the handle. Rotate the handle anti-clockwise to turn the product off.



Handle in the **OFF** Position



Handle in the **ON** Position at
MAX TEMPERATURE



Handle in the **ON** Position in
TEMPERATURE OVERRIDE

Note: With some water systems there may be insufficient water flow to operate both together

User Maintenance

WARNING! PLEASE OBSERVE THE FOLLOWING TO REDUCE THE RISK OF INJURY OR PRODUCT DAMAGE:

- DO NOT allow children to clean or perform any user maintenance to the shower unit without supervision.
- If the shower is not to be used for a long period, the water supply to the shower unit should be isolated. If the shower unit or pipework is at risk of freezing during this period, a qualified, competent person should drain them of water.

Filter Cleaning

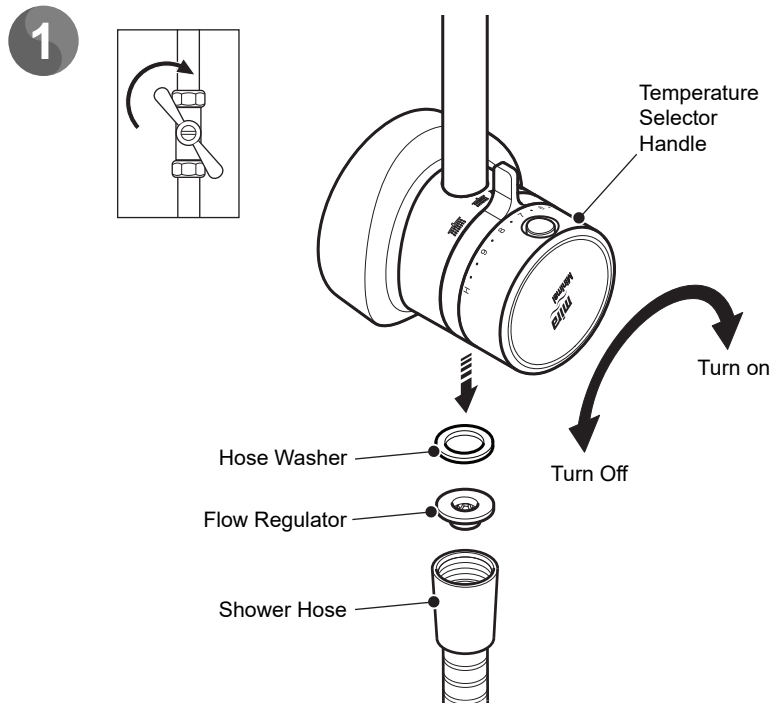

Isolate the water supplies and turn the shower on to relieve the water pressure. Turn the shower off.

Disconnect the hose from the shower unit. Retain all parts carefully for re-installation.

2 Only for Dual Outlet

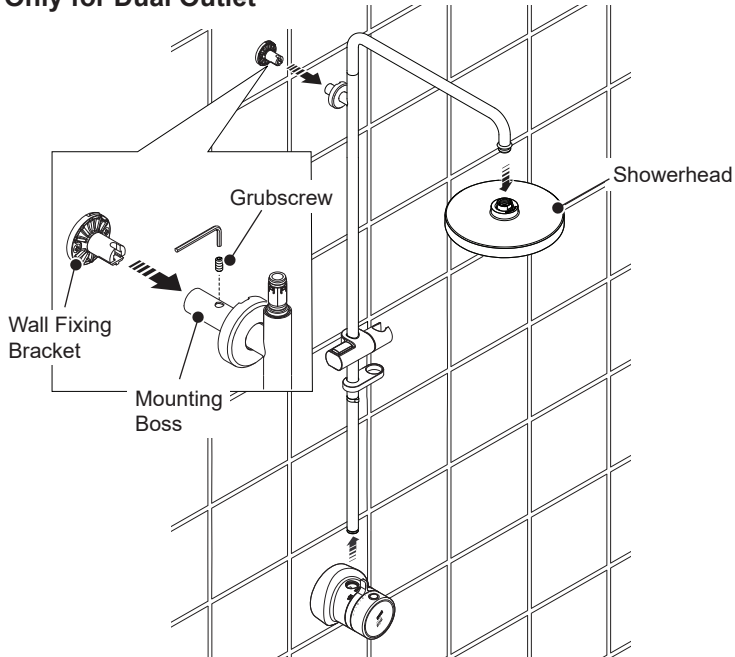

Carefully remove the showerhead from the fittings.

Loosen the grubscrew on top of the mounting boss and carefully remove the shower fittings from the wall fixing bracket then remove the lower bar from the mixing valve.

Retain all parts for re-installation.

3

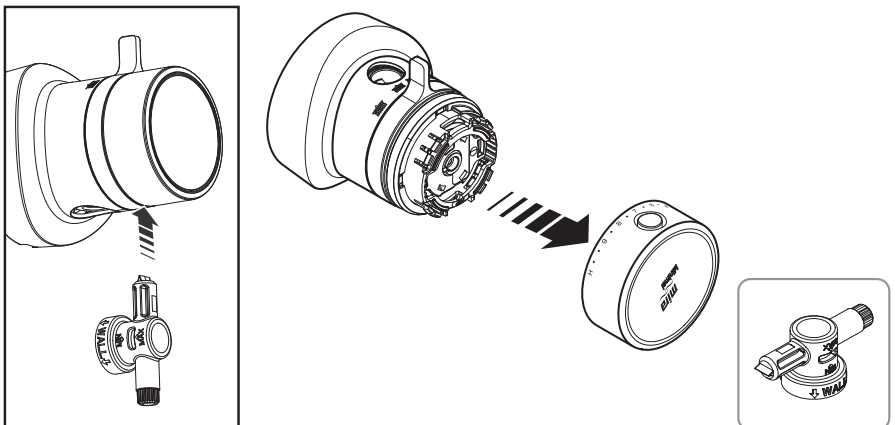

Remove the handle by using the blade on the installation aid, place in between the bottom of the handle and shroud and twist to unclip the handle.

4

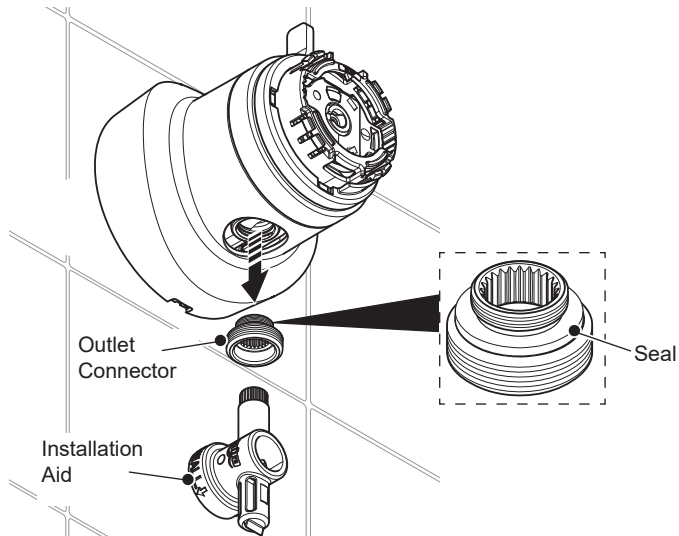

Remove the outlet connector along with the seal from bottom of the valve using the installation aid provided.

5

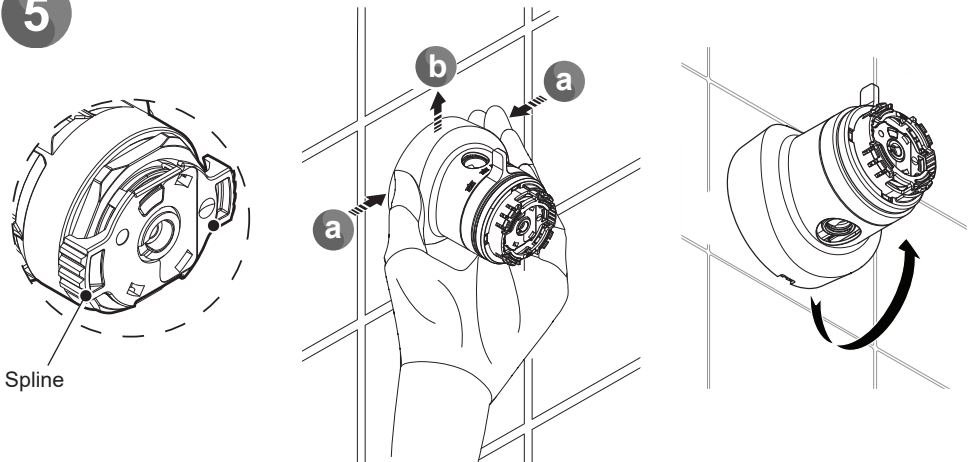

Note: Ensure that the spline is oriented in line as shown above.

Apply pressure to the sides of the shroud, try to slide shroud down and away from the wall until the bottom clip is disengaged. Then, still applying pressure to the sides, slide the shroud up to remove from the clip.

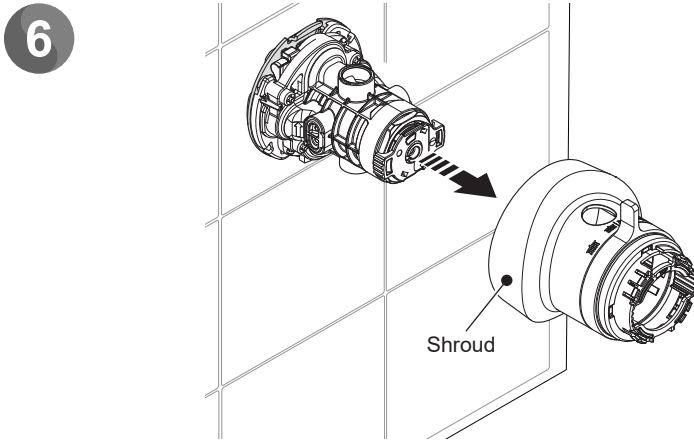

Pull out the shroud from valve assembly.

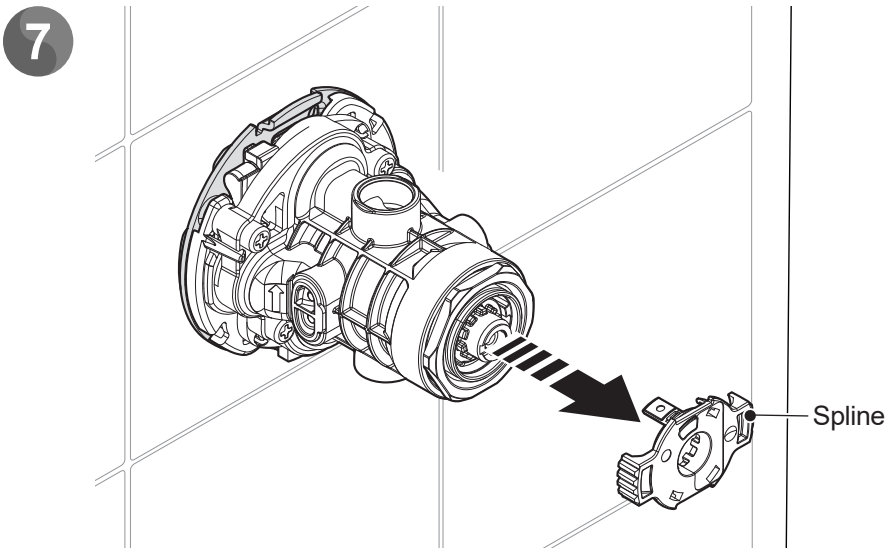

Carefully pull out the spline along with the lug from mixing valve.

8

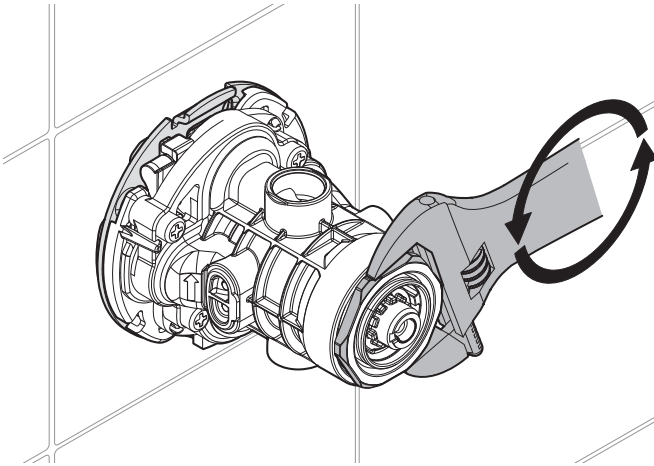

Carefully loosen the hexagonal head nut as shown.

9

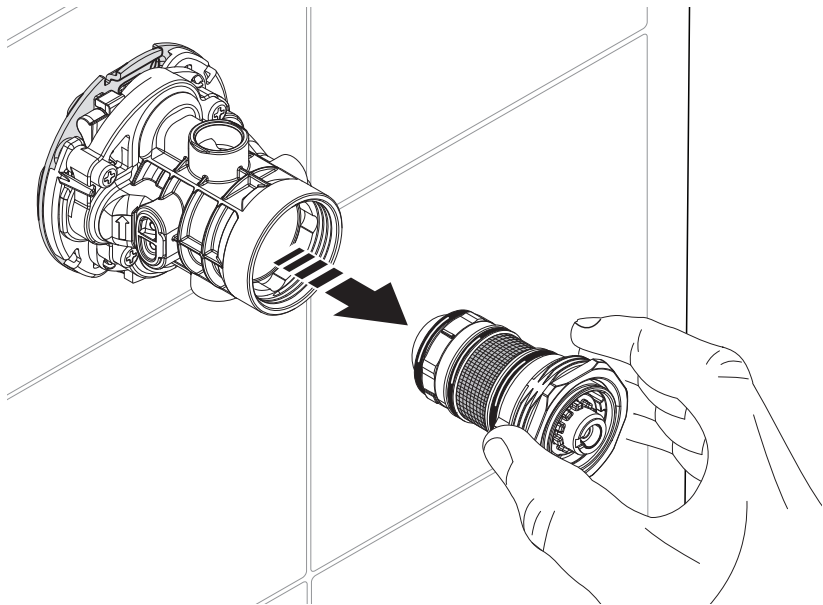

Carefully pull out the cartridge from the valve body.

10

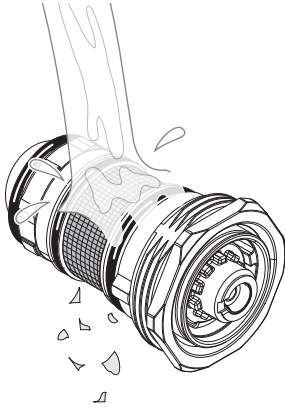

Rinse the filter in clean warm water, removing any dirt or debris.

Replace if the filter mesh is damaged.

11

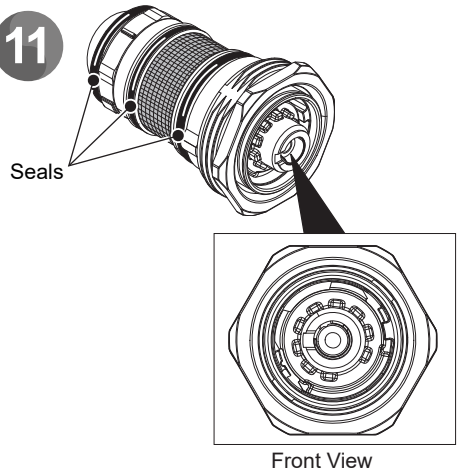

Note: Make sure that the seals are positioned in place and the cartridge locates correctly.

Refit the cartridge and spline in reverse order.

12

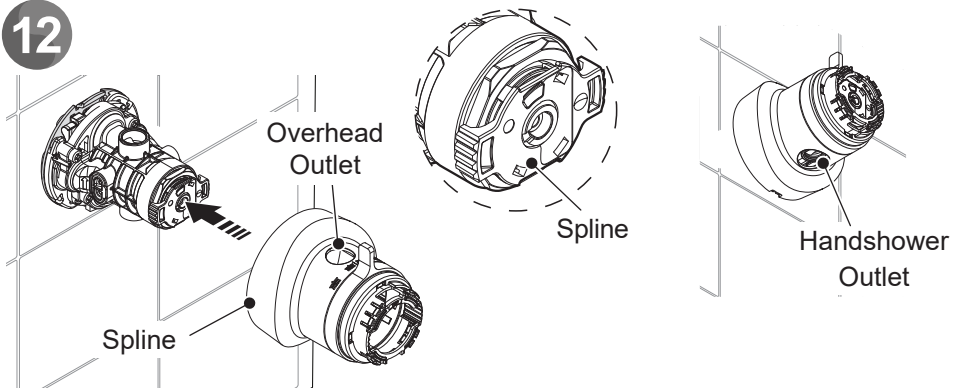

Note: Ensure that the spline is oriented in line as shown above.

Slide the shroud over the valve until shroud touches the clips, ensure outlets are in the correct position and drive features match. The shroud should click and clip into place.

Pull the shroud gently and wobble to ensure its clipped into place.

Refit the outlet connector, handle and shower fittings in reverse order.

Restore the water supplies and check for leaks.

Cleaning

Always read the IMPORTANT SAFETY INFORMATION for your shower.

Cleaning the showerhead

Many household and commercial cleaners, including hand and surface cleaning wipes contain abrasive and chemical substances that can damage plastics, plating and printing and should not be used. These finishes should be cleaned with a mild washing up detergent or soap solution, and then wiped dry using a soft cloth.

De-scaling the Showerhead and inspecting the hose

It is IMPORTANT to keep the Showerhead and Hose clean and free from blockage to make sure your shower performs to its optimum. The showerhead MUST be regularly cleaned and the hose MUST be regularly inspected to ensure there is no internal collapse or blockage that could reduce the flow.

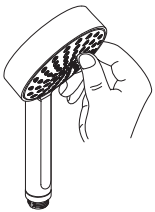

Use your thumb or a soft cloth to wipe any limescale from the soft nozzles.

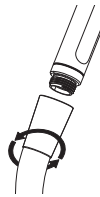
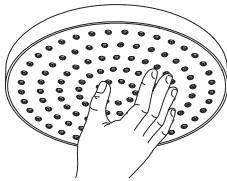

Unscrew the hose from the showerhead and the shower outlet.

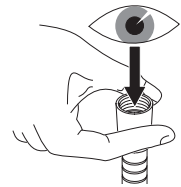

Inspect the hose.

Warning! Failure to keep the showerhead nozzles clear or inspect the hose for blockage or internal/external collapse can restrict the flow rate from the shower. This may cause damage to the shower or result in the temperature delivered to the user rising to unsafe levels with a risk of scalding. You MUST ALWAYS check the temperature before using the shower.

Fault Diagnosis

If you require a Mira trained service engineer or agent, refer to '**Customer Service**'.

Symptom	Cause/Rectification
Water too hot or too cold	Inlets reversed (hot supply to cold supply). Rework inlet pipework. Check filters for any blockage. Check the maximum temperature setting (If you have a combination type boiler it may not be producing sufficient hot water at the desired flow rate). Fit a flow regulator to the shower valve outlet. Installation conditions outside operating parameters. Refer to Specifications and Commissioning .
Poor temperature control	Make sure that the inlet temperature differentials are sufficient, refer to ' Specifications '. If fitted to a combi boiler ensure there is sufficient pressure and flow to deliver a constant hot water inlet supply. Check the shower handset, hose and inlet filters for any blockage and clean where necessary.
Fluctuating or reduced flow	Check the shower handset, hose and filters for any blockage. Make sure that the maintained inlet pressures are nominally balanced and sufficient. Refer to Specifications. Air lock or partial blockage in the pipework.
Water leaking from the shower handset/overhead	Normal for a short period after shut off. Check that the pressures are not in excess of the specifications for this product. There may be occasions where the overhead shower or shower handset empties for a while after the shower has been used, this is due to changes in ambient temperatures and is normal. It is recommended that all outlets are therefore enclosed within the water catchment area.

What to do if something goes wrong

If your product does not work correctly check that it is installed and commissioned in accordance with our instructions. If this does not resolve the issue, contact us for help and advice. Refer to Customer Service page for more details.

Spare Parts

A list of spares for these products are available from the Mira Website, visit website www.mirashowers.com.

Activate your Free* Guarantee

Thank you for choosing Mira. By registering your product, this will act as your proof of purchase and enable us to provide the best possible after sales service.

REGISTER NOW visit the Mira website guarantee page

www.mirashowers.co.uk/support/guarantee.htm

(You will need the Model Name, Product Code and Date of Manufacture. This information can be found on the front page of this guide)

* If you do not activate your guarantee proof of purchase will be required.

Mira has appointed Domestic & General Insurance PLC to provide product registration services and protection plans to accompany its products.

What we do with your information

At Domestic & General we want to reassure you that we use your information both responsibly and securely to provide you with the best possible service. Below we explain what we do with your information and your rights to your information. If you would like any further details you can get in touch with us using the contact details below or visit our website (www.domesticandgeneral.com).

Using your information

Domestic & General Insurance PLC ("we") is the "data controller" of your information. We process two sets of information about you, "Personal Information" (your name, address, contact and payment details) and the "Goods Information" you provide to register your appliance or device (your name, address, contact and goods details). We'll use your information:

(i) As necessary to fulfil our contract with you (including to recover any amounts owing); (ii) for our legitimate interests in: undertaking marketing (about our products and services and those of our third party partners) by post, telephone, email and/or other electronic messaging services; market research; customer surveys; printing services; checking and verifying your identity and contact details; recording your conversations for training, quality and compliance purposes; and for analytics and profiling for marketing purposes; and (iii) where required to do so by law. We may also ask for your consent to some uses of your information.

Sharing your information

From time to time your Personal Information and Goods Information may also be shared with other members of the Domestic & General Group of Companies (Domestic & General Insurance or Services and other future members of the Group whose details we will notify to you ("Group")), where applicable with Kohler Mira Limited which is the subject of your protection policy and with companies acting on our behalf or providing services to us (e.g. the companies we use to carry out repairs, IT & mailing services, storage of paper records and telecommunications). Kohler Mira Limited will process your Personal Information for their legitimate business interests (including marketing and analytics) in accordance with their privacy policy.

Transferring your information

In exceptional cases, we may transfer your information to countries outside the European Economic Area (including the US) which may not have data protection laws which provide the same level of protection as provided in the UK. We have put in place Model Clauses as an appropriate safeguard to ensure that such information is adequately secured and protected and that such transfers meet the requirements of applicable data protection law.

Keeping your information

We keep your Personal Information for six years after you terminate your policy so that we can deal with any claims. Your goods information that we keep for a bit longer, normally 10 years (the average life of an appliance) for health and safety. We also keep your information to send you marketing that you might be interested in, unless we receive a request from you to opt-out of marketing.

Rights to your information

By writing to the Data Protection Officer using the contact details provided below, you have the right to ask us:

- For a copy of the Personal Information we hold about you
- For a copy of the Personal Information you provided to us to be sent to you or a third party in a commonly used, machine readable format
- To update or correct your Personal Information to keep it accurate
- To delete your Personal Information from our records if it is no longer needed for the original purpose; and
- To restrict the processing of your Personal Information in certain circumstances

And you may also:

- Object to us processing your Personal Information, in which case we will either agree to stop processing or explain why we're unable to, and
- Where we rely on your consent, withdraw that consent at any time

Please note that the above rights are not absolute and certain exemptions apply to them. You can also make a complaint to the Information Commissioner (www.ico.org.uk) if you feel your Personal Information has been mishandled.

Marketing

We, along with other members of our Group and Kohler Mira Limited may use your information to tell you about any offers, products or services which may be of interest to you. We may contact you by post, telephone, email and/or other electronic messaging services.

To change your marketing preference, let us know by emailing marketingpreferences@domesticandgeneral.com or by writing to us using the contact details provided below. For Kohler Mira Limited marketing you'll need to contact them directly using their contact details that you'll normally find in their privacy notice.

Contact Details

If you need to contact us about your information or your information rights, or to see a copy of our Model Clauses, please write to Freepost Plus RTKS-CLRA-GRYE, Data Protection Officer, Domestic & General, Leicester House, 17 Leicester Street, Bedworth CV12 8JP or dataprotection@domesticandgeneral.com and we'll be happy to help you.

Notes

Notes

Customer Service

Guarantee

Your product has the benefit of our manufacturer's guarantee which starts from the date of purchase. This guarantee only applies in the United Kingdom and Republic of Ireland.

Activating Your Guarantee

Registering your guarantee is quick and simple. To ensure your product is covered, please register online.



Scan the QR code to activate your guarantee now or call 0800 5978551 within 30 days of purchase (UK only).

What is Covered:

- The guarantee applies solely to the original installation under normal use.
- The product must be installed and maintained in accordance with the instructions given in this guide.
- Servicing must only be undertaken by us or our appointed representative.
- Repair under this guarantee does not extend the original expiry date. The guarantee on any replacement parts or product ends at the original expiry date.
- For shower fittings or consumable items we reserve the right to supply replacement parts only.

The guarantee does not cover:

- Call out charges for non product faults (such as damage or performance issues arising from incorrect installation, improper use, inappropriate cleaning, lack of maintenance, build up of limescale, frost damage, chemical attack, corrosion, system debris or blocked filters) or where no fault has been found with the product.
- Water or electrical supply, waste and isolation issues.
- Routine maintenance or replacement parts to comply with the requirements of Building / Plumbing / Electrical Standards or Schemes.
- Compensation for loss of use of the product or consequential or indirect loss of any kind.
- Damage or defects caused if the product is repaired or modified by persons not authorised by us or our appointed representative.
- Accidental or wilful damage.
- Products purchased ex-showroom display.
- Disinfection or descaling to reduce bacterial growth or contamination.

What to do if something goes wrong

If your product is not working correctly please refer to this manual for fault diagnosis and to check that it is installed and commissioned in accordance with our instructions. If this does not resolve the issue, our Customer Services team are here to help get you back up and running. To help us solve your problem quickly, please have your product name, power rating (if applicable) and date of purchase to hand.

Visit www.mirashowers.co.uk

Visit our website to register your guarantee, book a service visit, diagnose faults and purchase products.

Spares and Accessories

We stock a full range of spare parts and fittings and are all available to purchase either online or over the phone. Our online spare parts selector tool will help you quickly and easily identify the spare part for your product.

Visit www.mirashowers.co.uk/parts-accessories

Replacements and Repairs

In the unlikely event that your product needs a repair, our nationwide repairs and installation team are here to help. You can book a convenient date and time online.



Scan the QR code to book a service visit now or visit www.mirashowers.co.uk/support/repair-services/repair-service

We also offer a comprehensive replacement service for when your product needs a little refresh, visit our website or contact our team for more information on our replacement services.

Help us improve

Your experience is important to us and your review (whether good, bad or otherwise) will be posted on Trustpilot.com immediately to help other people make more informed decisions.

Visit uk.trustpilot.com/review/www.mirashowers.co.uk

Need to get in touch?

UK

T: 0800 001 4040
E: askus@mirashowers.com
www.mirashowers.co.uk

Eire

T: 01 531 9337
E: customerserviceire@mirashowers.com
www.mirashowers.ie

Mira is a registered trade mark of Kohler Mira Limited.

The company reserves the right to alter product specifications without notice.

Registered Office:
Cromwell Road,
Cheltenham,
Gloucestershire
GL52 5EP

EU Importer address
K/E S.A.S.
3 rue de Brennus,
93631, La Plaine Saint-Denis,
France



mira
SHOWERS