

# ***mira***

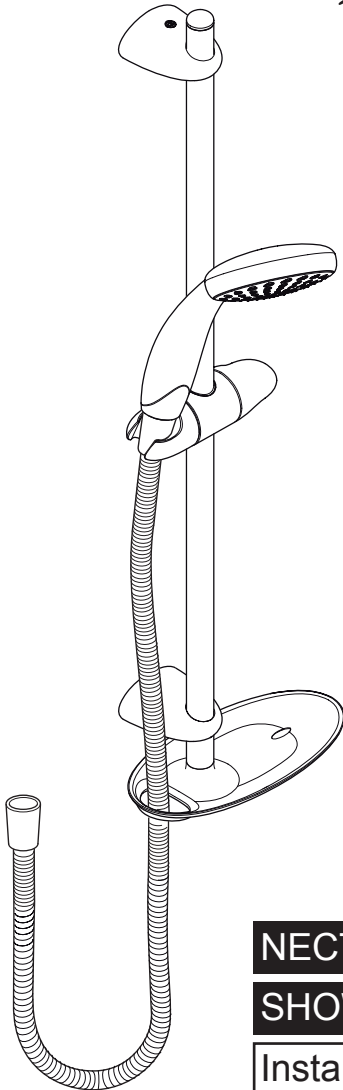

## **SHOWERS**



**NECTAR**

**SHOWER FITTINGS**

**Installation and User Guide**

**These instructions are to be left with the user**

# INTRODUCTION

Thank you for purchasing a quality Mira product. To enjoy the full potential of your new product, please take time to read this guide thoroughly, having done so, keep it handy for future reference.

## Nectar Shower Fittings

The Adjustable Showerhead has four different spray actions and is supplied complete with Shower Hose, Clamp Bracket, Slide Bar Supports, and a Soap Dish.

These shower fittings are designed for use with all Mira products.

Available in chrome and white/chrome finish.

# IMPORTANT SAFETY INFORMATION

## Warning!

1. Products manufactured by us are safe and without risk provided they are installed, used and maintained in good working order in accordance with our instructions and recommendations.

## Caution!

1. Read all of these instructions.
2. Retain this guide for later use.
3. Pass on this guide in the event of change of ownership of the installation site.
4. Follow all warnings, cautions and instructions contained in this guide.
5. Anyone who may have difficulty understanding or operating the controls of any shower should be attended whilst showering. Particular consideration should be given to the young, the elderly, the infirm, or anyone inexperienced in the correct operation of the controls.
6. This appliance is not intended for use by persons (including children) with reduced physical, sensory or mental capabilities, or lack of experience and knowledge, unless they have been given supervision or instruction concerning the use of the appliance by a person responsible for their safety.
7. Children should be supervised to make sure that they do not play with the appliance.
8. **DO NOT** position the showerhead to spray water directly on to the appliance. Eg. When cleaning shower control.
9. **DO NOT** fit any form of flow control in the shower outlet.
10. Having completed the installation, make sure that the user is familiar with the operation of the appliance.
11. Sunburn or skin conditions can increase your sensitivity to hot water.
12. When this product has reached the end of its serviceable life, it should be disposed of in a safe manner, in accordance with current local authority recycling, or waste disposal policy.

# GUARANTEE

## Guarantee

For **domestic installations**, Mira Showers guarantee the products listed in this guide against any defect in materials or workmanship for a period of one year from the date of purchase.

For **non-domestic installations**, Mira Showers guarantee the product against any defect in materials or workmanship for a period of one year from the date of purchase.

For terms and conditions refer to the back cover of this guide.

Recommended Usage	
Domestic	✓
Light Commercial	✓
Heavy Commercial	✗
Healthcare	✗

## Design Application:

EU: 001169197-001

If you experience any difficulty with the installation or operation of your new Shower Fittings, please refer to '**Fault Diagnosis**', before contacting Kohler Mira Ltd. Our telephone and fax numbers can be found on the back cover of this guide.

# PACK CONTENTS



Tick the appropriate boxes to familiarise yourself with the part names and to confirm that the parts are included.

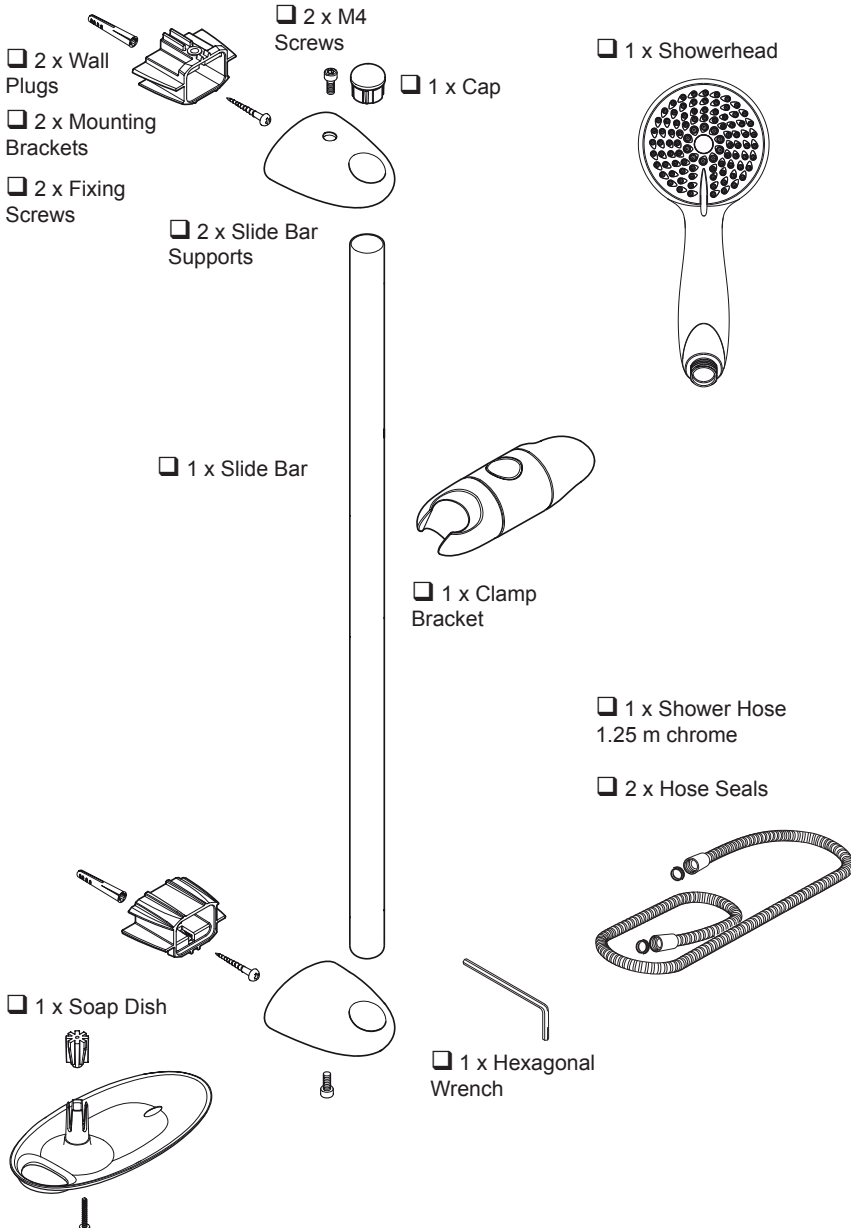

# DIMENSIONS

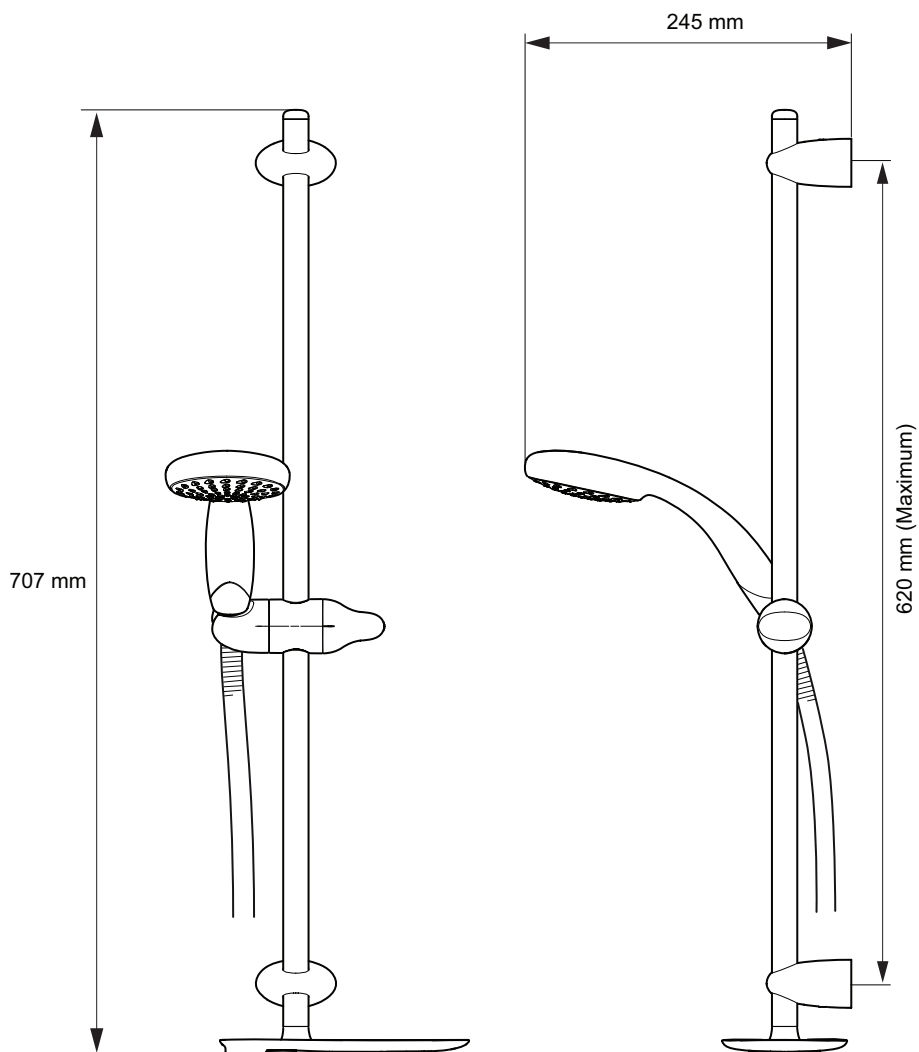

# SPECIFICATIONS

## Pressures

Minimum maintained pressure: **0.1 bar** (10 kPa).

Maximum maintained pressure: **5.0 bar** (500 kPa).

**Warning!** Exceeding the stated maximum maintained pressure could result in excessive spray forces and possible damage to the product.

# INSTALLATION REQUIREMENTS

Installation must be carried out in accordance with these instructions, and must be conducted by designated, qualified and competent personnel.

1. The soap dish supplied **must** be used to stop the showerhead from dropping below the spill-over level of the bath or shower tray. Pass the hose through the soap dish and ensure there is a minimum of 25 mm between the showerhead and bath/tray spill-over level. This will prevent water supply contamination due to back-siphonage.
2. Installations **must** comply with UK Water Regulations/ Bye-laws (Scotland), and Building and Plumbing Regulations in force at the time of installation
3. Avoid layouts where the shower hose will be sharply kinked. This may reduce the life of the hose.
4. **Do not** fit any form of flow control in the shower outlet.
5. **Do not** use excessive force when making connections.
6. **Do not** install the fittings in a position where it could become frozen.

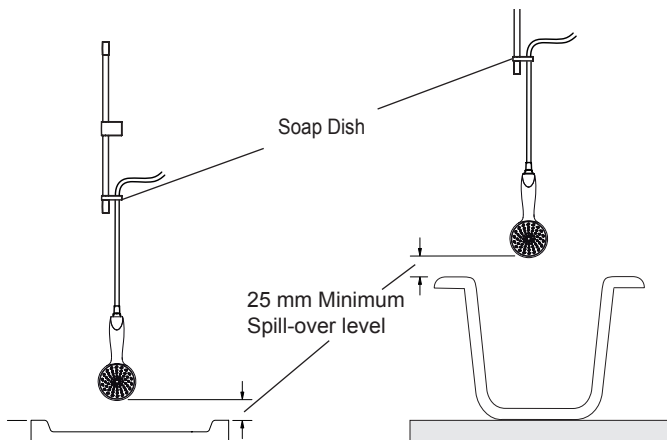

# INSTALLATION

**Note!** For dry lined, stud partition, shower cubicle or laminated panel walls the installer may wish to obtain alternative proprietary cavity fixings. Use of these alternative fixings is beyond the scope of this guide.

Read the section: **Installation Requirements** before proceeding with the installation.

The slide bar should be positioned to one side of the shower control at a convenient height for all the family. It should be positioned so that the showerhead discharges down the centre line of the bath, or across the opening of the shower cubicle. The showerhead should be directed away from the shower control.

1. Decide on a suitable position for the slide bar avoiding buried cables and pipes.
2. Mark the wall fixing hole positions and drill two holes to suit the wall fixings and insert the wall plugs.

**Note!** For new installation optimum fixing centres 600 mm. Replacement installation fixing centres 620 mm maximum.

3. Install the wall plugs and mounting brackets and secure with the screws. Check vertical alignment.

**Note!** The mounting brackets are slotted to aid adjustment.

4. Install the clamp bracket and the slide bar supports onto the slide bar.

**Note!** Some components may already be pre-assembled.

5. Fit the slide bar supports over the mounting brackets. Adjust the slide bar vertically ensuring an equal length of slide bar protrudes from the top and bottom mounting bracket.

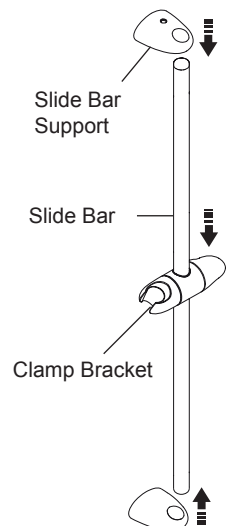
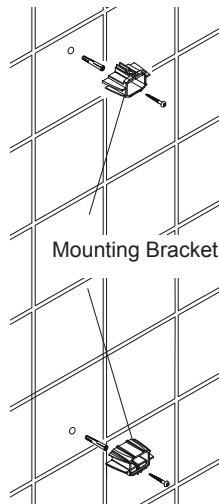

6. Remove the slide bar assembly preventing any movement between the slide bar and slide bar supports.

7. Tighten the two slide bar clamping screws.

**Note!** When tightening the screws **do not** over tighten. Half a turn maximum is all that is required.

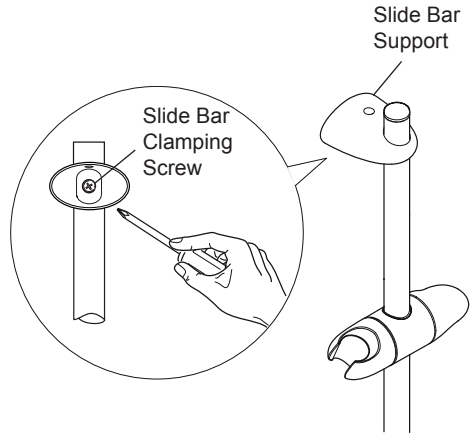

8. Install the slide bar assembly onto the mounting brackets and tighten the 2 x M4 screws

9. Install the end cap.

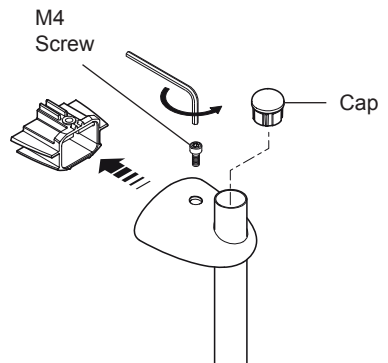

## Soap Dish Installation

1. Install the taper block onto the soap dish.

2. Install soap dish screw into the taper block.

3. Install the soap dish assembly into the slide bar and tighten the soap dish screw.

4. Pass the flexible hose through the soap dish.

5. Install the hose onto the showerhead and the outlet of the shower control or RAC assembly (Make sure the hose seals are fitted) **Do not overtighten.**

6. Place the showerhead onto the clamp bracket assembly.

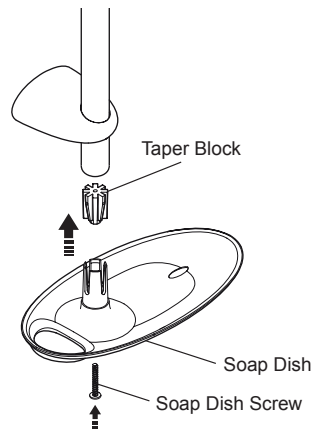



# OPERATION

## Height Adjustment.

The height of the showerhead is easily adjusted by turning the knob on the clamp bracket and gently moving the clamp bracket either up or down the slide bar until the required height is achieved.

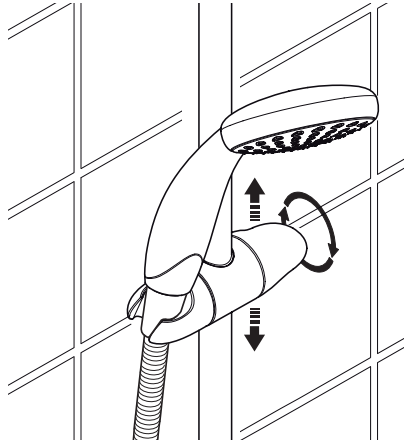

## Selecting Showerhead Spray.

The adjustable showerhead has four different spray actions.

1. To select any of the four spray actions, turn the spray plate anticlockwise from the full clockwise position until it clicks once.

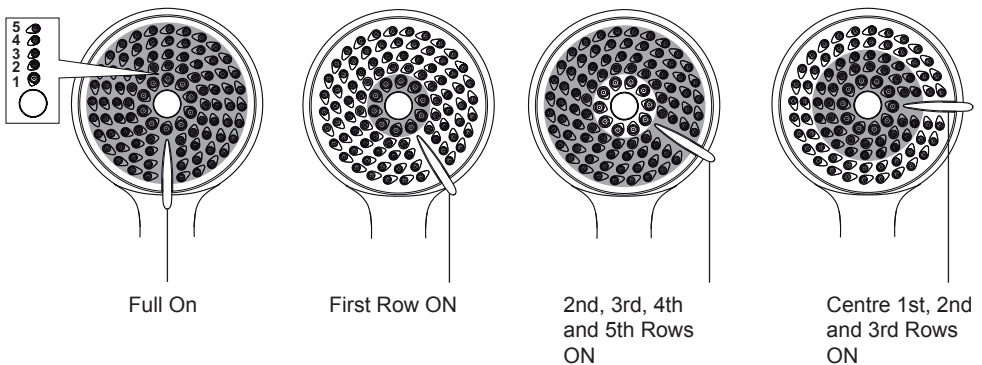

**Note!** The shaded area shows the spray nozzles selected.

# MAINTENANCE

## Cleaning

Many household cleaners contain abrasives and chemical substances, and should not be used for cleaning plated or plastic fittings. These finishes should be cleaned with a mild washing up detergent or soap solution, and then wiped dry using a soft cloth.

1. Use your thumb or a soft cloth to wipe any limescale from the soft rubber nozzles and the front face of the spray plate assembly **Important!** The sprayplate must be regularly cleaned to make sure that the showerhead does not become blocked.

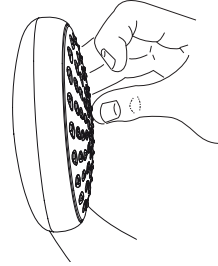

# FAULT DIAGNOSIS

The trouble shooting information tabled below gives details on what you can do as a user, should you encounter difficulties with the shower fittings whilst operating the shower. Before replacing any parts make sure that the underlying cause of the malfunction has been resolved.

Malfunction	Cause	Remedy
No flow or low flow rate from shower fittings.	Spray plate blocked.  Hose blocked or twisted.  Problem with shower control.	Refer to section <b>'Maintenance, Cleaning'</b> .  Clear blockage or release twist in hose or renew hose.  Refer to the shower control Installation and User Guide.
Drip from spray plate assembly in Showerhead.	A small amount of water may be retained in the shower fitting after the shower control has been turned off. This may drain over a few minutes.	This is quite normal. Changing the angle of the showerhead may vary the draining time.
Shower temperature changes when spray action is adjusted.	Adjusting the spray action changes the flow of water. This may affect some shower controls and plumbing installations.	To minimise the effect make sure that the spray plate is clean. Refer to section: <b>'Maintenance, Cleaning'</b> . If the malfunction persists refer to the shower control Installation and User Guide.

## SPARE PARTS

- 632.73 Hose Seal (x2)
- 1603.104 Shower Hose 1.25m (metal) - Chrome
- 1703.078 Slide Bar 680 mm - Chrome
- 1703.127 Slide Bar 680 mm - Brushed Stainless Steel
- 1703.195 Taper Block
- 1703.269 Mounting Pack - components identified 'A'
- 1703.271 End Cap
- 1703.272 Soap Dish
- 1703.273 Slide Bar Support - White
- 1703.274 Slide Bar Support - Chrome <sup>1703.275</sup>  
<sub>1703.276</sub>
- 1703.275 Clamp Bracket - White
- 1703.276 Clamp Bracket - Chrome
- 1703.297 Nectar Showerhead - Chrome
- 1703.298 Nectar Showerhead - White
- 1703.299 Nectar Adjustable Showerhead - Chrome
- 1703.300 Nectar Adjustable Showerhead - White

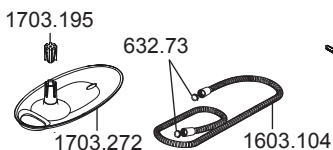
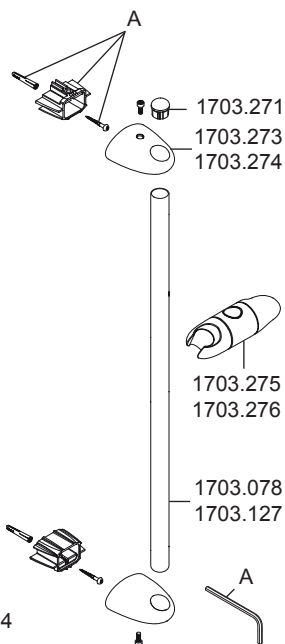

## ACCESSORIES

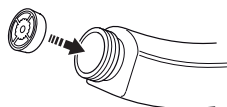

### Flow Regulator (12 L/min - Red) - 1641.059

If your shower has no flow control, you may find operation of the shower on high pressure systems too forceful. Fitting a flow regulator in the showerhead will reduce this.

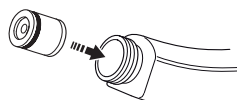

### Checkvalve - 1688.282

To comply with UK Water Regulations you must make provision to prevent the backflow of waste water through the shower.

A hose retaining ring will allow compliance but may restrict full use of the hose.

However, if your mixer shower is already fitted with single inlet checkvalves then fitting the extra showerhead checkvalve will allow compliance without the need for the hose retaining ring.

# CUSTOMER SERVICE

## Guarantee

Your product has the benefit of our manufacturer's guarantee which starts from the date of purchase.

To activate this guarantee, please return your completed registration card, visit our website or free phone 0800 0731248 within 30 days of purchase (UK only).

Within the guarantee period we will resolve defects in materials or workmanship, free of charge, by repairing or replacing parts or product as we may choose.

**This guarantee is in addition to your statutory rights and is subject to the following conditions:**

- The product must be installed and maintained in accordance with the instructions given in this user guide.
- Servicing must only be undertaken by us or our appointed representative. **Note!** if a service visit is required the product must be fully installed and connected to services.
- Repair under this guarantee does not extend the original expiry date. The guarantee on any replacement parts or product ends at the original expiry date.
- For shower fittings or consumable items we reserve the right to supply replacement parts only.

**The guarantee does not cover:**

- Call out charges for non product faults (such as damage or performance issues arising from incorrect installation, improper use, lack of maintenance, build up of limescale, frost damage, corrosion, system debris or blocked filters) or where no fault has been found with the product.
- Water or electrical supply, waste and isolation issues.
- Compensation for loss of use of the product or consequential loss of any kind.
- Damage or defects caused if the product is repaired or modified by persons not authorised by us or our appointed representative.
- Routine maintenance or replacement parts to comply with the requirements of the TMV 2 or TMV 3 healthcare schemes.

## What to do if something goes wrong

If your product does not function correctly when you first use it, contact your installer to check that it is installed and commissioned in accordance with the instructions in this manual.

Should this not resolve the issue, contact our Customer Services Team who will offer you or your installer advice and if applicable arrange for a Service Technician to call.

If the performance of your product declines, check in this manual to see if simple home maintenance is required. If you require further assistance call our Customer Services Team.

## Extended Guarantees

A selection of protection plans are available that enable you to cover repair bills for the life of your policy (excludes Eire). Ring 01922 471763 for more details.

## Helpdesk Service

Our dedicated Customer Services Team is comprehensively trained and can offer help and advice, spare parts, accessories or a service visit. We will need you to have your model name or number, power rating (if applicable) and date of purchase. As part of our quality and training programme calls may be recorded or monitored.

**Mira Showers Website ([www.mirashowers.co.uk](http://www.mirashowers.co.uk))**

From our website you can register your guarantee, download additional user guides, diagnose faults, purchase our full range of accessories and popular spares, refer to our FAQ's and request a service visit.

## Spares and Accessories

We maintain extensive stocks of genuine spares and accessories and aim to provide support throughout the product's expected life. Payment can be made by phone at time of order using most major Credit or Debit cards and we aim to despatch orders within two working days. Items purchased from us are guaranteed for 12 months from date of purchase. For safety reasons spares exposed to mains voltages should only be fitted by competent persons.

**Returns** – items can be returned within one month of date of purchase, providing that they are in good condition and the packaging is unopened. Please obtain authorisation from our Customer Services Team before return. We reserve the right to apply a 15% restocking charge.

## Service / Repairs

We have a nationwide team of Service Technicians who can carry out all service or repair work to your product within the guarantee period and beyond. You have the assurance of a fully trained Mira Technician, genuine Mira spare parts and a 12 month guarantee on any chargeable work done.

Payment should be made directly to the Service Technician who will accept most major Credit or Debit cards.

## To Contact Us

### UK

**Telephone: 0844 571 5000**

Mon to Fri 8:00 am - 5:30 pm, Sat 8:30 am - 3:30 pm

E-mail: [technical@mirashowers.com](mailto:technical@mirashowers.com)

Fax: 01242 282595

By Post: Mira Customer Services Dept, Cromwell Road, Cheltenham, Gloucestershire, GL52 5EP

### Eire

**Telephone: 01 459 1344**

Mon to Fri 9:00 am - 5:00 pm

E-mail: [sales@modernplant.ie](mailto:sales@modernplant.ie)

Fax: Dublin 01 459 2329

By Post: Modern Plant Ltd (Dublin), Otter House, Naas Road, Clondalkin, Dublin 22

Mira is a registered trade mark of  
Kohler Mira Limited.

The company reserves the right to alter  
product specifications without notice.



**mira**  
SHOWERS