

## Technical Specification For Plus series

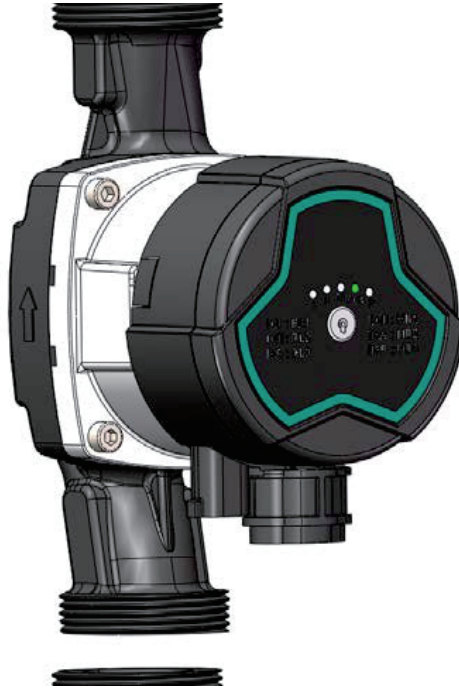

Product Name: Class A Energy Saving-Circulating Pump

Product Model: Plus Upgrade Anti-condensation

(Inrush current : <3A)

Version NO.: A/1

Document NO.: F220AZ25

Applicable Customer: Universal Version

Issue Date: 2024.06.12

Compiled:

Reviewed:

Approved:



## Content

1.	Product Introduction.....	5
1.1	Product Model Description .....	5
1.2	Scope of use .....	5
1.3	Product certification .....	5
2.	Product parameters.....	5
2.1	Basic parameters .....	5
2.2	Motor type.....	6
2.3	Surge current .....	6
2.4	Performance curve.....	7
2.4.1	Plus 4 performance curve .....	7
2.4.2	Plus 5 performance curve .....	7
2.4.3	Plus 6 performance curve .....	7
2.4.4	Plus 7 performance curve .....	8
2.4.5	Plus 7.5 performance curve .....	8
2.4.6	Plus 8 performance curve .....	8
3.	Product application conditions .....	9
3.1	Media requirements.....	9
3.2	Service environment requirements .....	9
3.3	Storage environment requirements.....	9
3.4	Comparison Table of Water Temperature and Inlet Pressure.....	9
4.	Product Installation Description .....	9
4.1	Nameplate parameters .....	9
4.2	Product installation direction diagram.....	10
4.3	Start and stop of pump.....	11
4.4	Illustration of an insulating cotton wrap.....	11
4.5	Panel display diagram explanation.....	12
4.5	Power connection .....	13
4.7.1	Signal connection .....	13
4.7.2	Interface circuit of PWM input signal .....	13
4.7.3	PWM output interface circuit .....	13
4.8	Electric control instructions.....	14
4.8.1	PWM 1 signal input.....	14
4.8.2	PWM 2 signal input.....	14
4.8.3	PWM feedback .....	15
4.8.4	<b>Fault protection description</b> .....	16
5.	Product testing.....	17
5.1	Factory inspection .....	17
5.2	Reliability test .....	18
6.	Packing method.....	18
6.1	Single product packaging .....	18
6.2	Mass production packing.....	18
7.	Instructions for use.....	19

---

7.1	Mobile dismantling .....	19
7.2	Prevention of frost cracking .....	19
7.3	Long term non use of circulating pumps .....	19
7.4	Motor overheating and abnormalities.....	19
7.5	Preventing Children from Touching .....	19
7.6	Installation direction of circulating pump .....	20
7.7	Installation Protection.....	20
7.8	Water hammer impact.....	20
7.9	Power connection leads .....	20
7.10	Prohibit the circulation pump from running out of water.....	20
7.11	Pumped Liquid .....	20
7.12	Scale inhibitors.....	20
7.13	Power grounding .....	20
7.14	Maintenance precautions.....	20
8.	Common fault causes and solutions .....	20
9.	Disclaimer .....	21
Annex	.....	22
a.	Assembly drawing and main part material table .....	22
b.	Installation dimension drawing.....	23
c.	Power interface.....	24

# 1. Product Introduction

## 1.1 Product Model Description

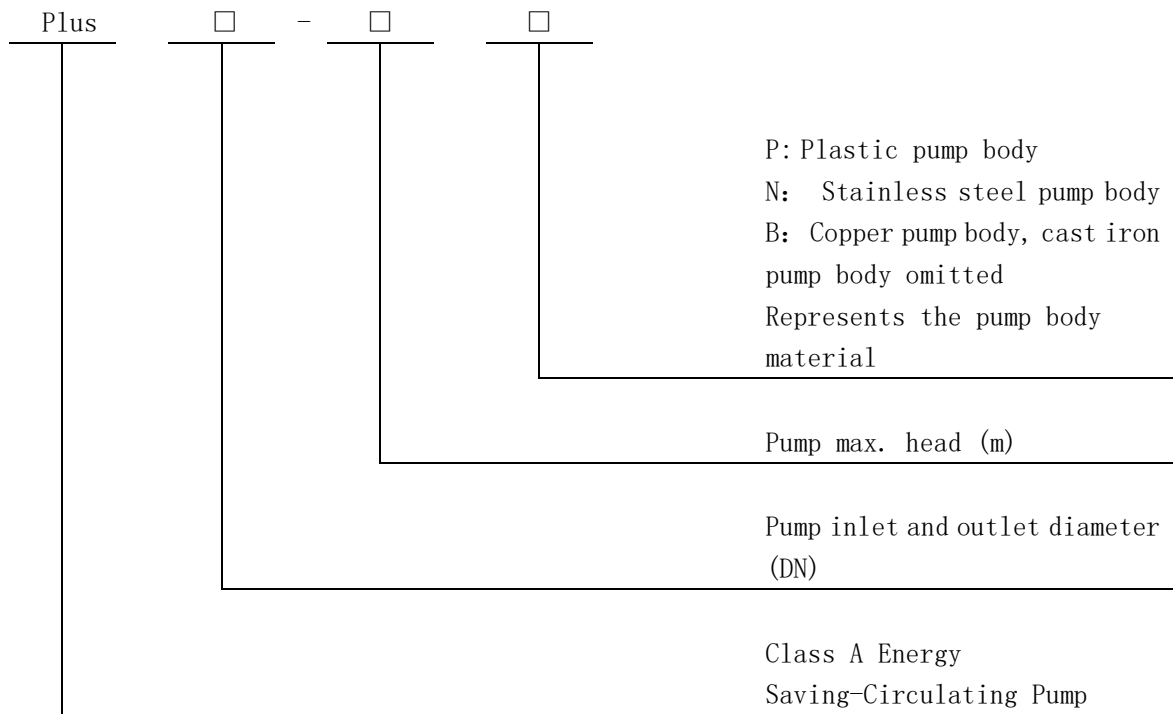

Type key example: Plus 25-8 stands for a pump with nominal diameter (DN) of suction and discharge ports of 25mm, maximum head of 8m, and cast iron pump housing, third-generation products, with functions of 10 shifts + PWM.

## 1.2 Scope of use

It can be used for heating, domestic hot water circulation system, etc

## 1.3 Product certification

The product meets the requirements of GS、CE、EMC certification

Note: RoHS2.0 and REACH are third-party test reports.

# 2. Product parameters

## 2.1 Basic parameters

voltage : 220-240V AC	frequency : 50/60Hz	Design pressure : 1.0MPa
Ingress protection : IP44	Inrush current : <3A	noises : <42dB (A)
vibration : ≤4.5mm/s	Standby power consumption : ≤3W	Insulation rating : H
Temperature rating : TF110	Steering: Clockwise from the impeller inlet	

Model number	Maximum flow (m <sup>3</sup> /h)	Maximum head (m)	Maximum power (W)	EEI:	Rated voltage (V)	Maximum current (A)
Plus 20-4	2.6	4	25	EEI ≤ 0.20-Part2	220-240	0.25
Plus 25-4	2.8	4	25		220-240	0.25
Plus 32-4	3.4	4	25		220-240	0.25
Plus 20-5	2.8	5	33		220-240	0.3
Plus 25-5	3	5	33		220-240	0.3
Plus 32-5	3.6	5	33		220-240	0.3
Plus 20-6	3	6	39		220-240	0.35
Plus 25-6	3.2	6	39		220-240	0.35
Plus 32-6	3.8	6	39		220-240	0.35
Plus 20-7	3.4	7	52		220-240	0.45
Plus 25-7	3.6	7	52		220-240	0.45
Plus 32-7	4.2	7	52		220-240	0.45
Plus 20-7.5	3.6	7.5	60		220-240	0.5
Plus 25-7.5	3.8	7.5	60		220-240	0.5
Plus 32-7.5	4.4	7.5	60		220-240	0.5
Plus 20-8	3.5	8	70	EEI ≤ 0.21-Part2	220-240	0.55
Plus 25-8	3.9	8	70		220-240	0.55
Plus 32-8	4.7	8	70		220-240	0.55

## 2.2 Motor type

Motor type: permanent magnet synchronous motor	Enameled wire material: copper	Magnetic steel material: neodymium iron boron
DC cold resistance of motor at 20 °C: 90.5 ± 5% Ω		Insulation level: H

## 2.3 Surge current

Test conditions:	Surge current	Duration
T=20±5 °C	<3A	<4ms

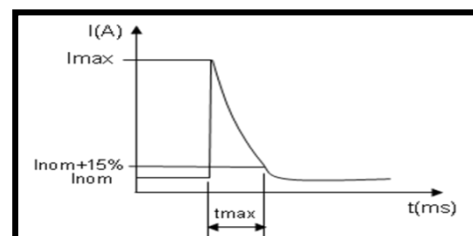

## 2.4 Performance curve

This performance curve is suitable for normal temperature water, such as pump for non-water medium, the hydraulic performance of the pump will be reduced, therefore, in the selection of pump, must consider the characteristics of the liquid medium.

### 2.4.1 Plus XX-4 performance curve

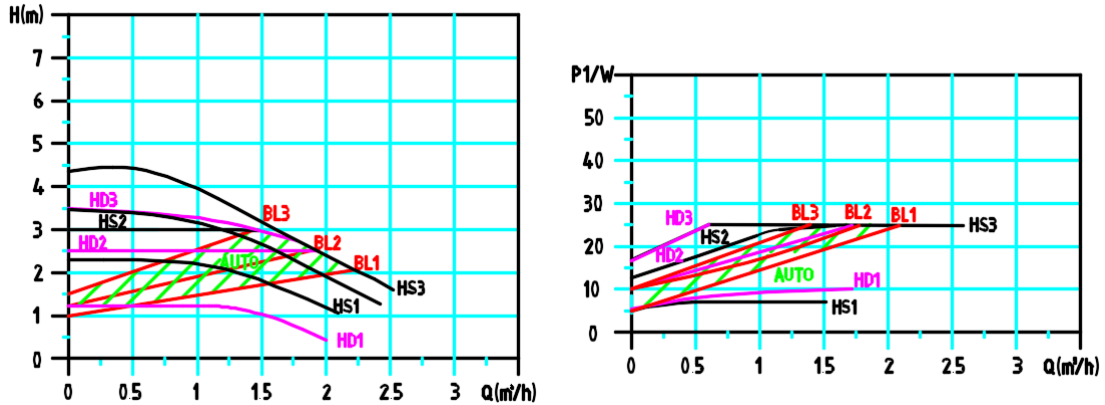

### 2.4.2 Plus XX-5 performance curve

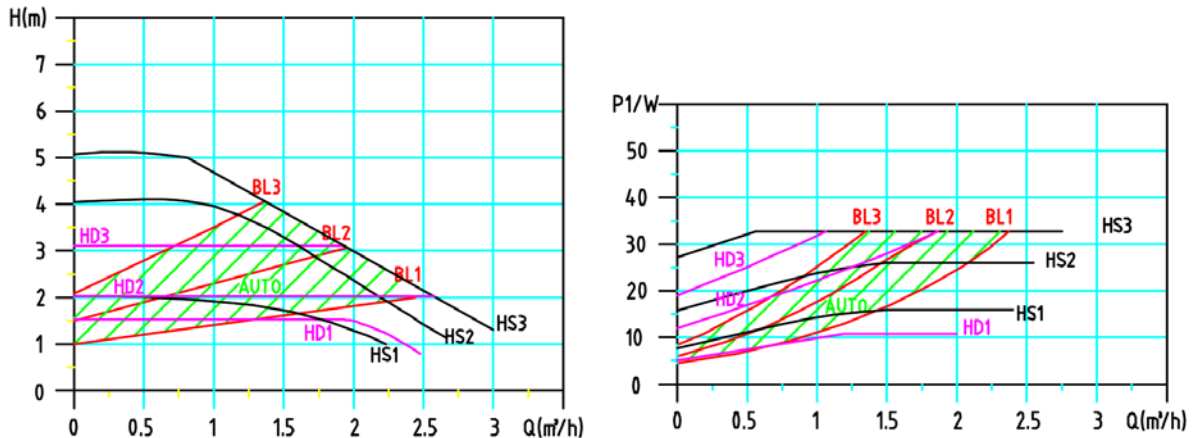

### 2.4.3 Plus XX-6 performance curve

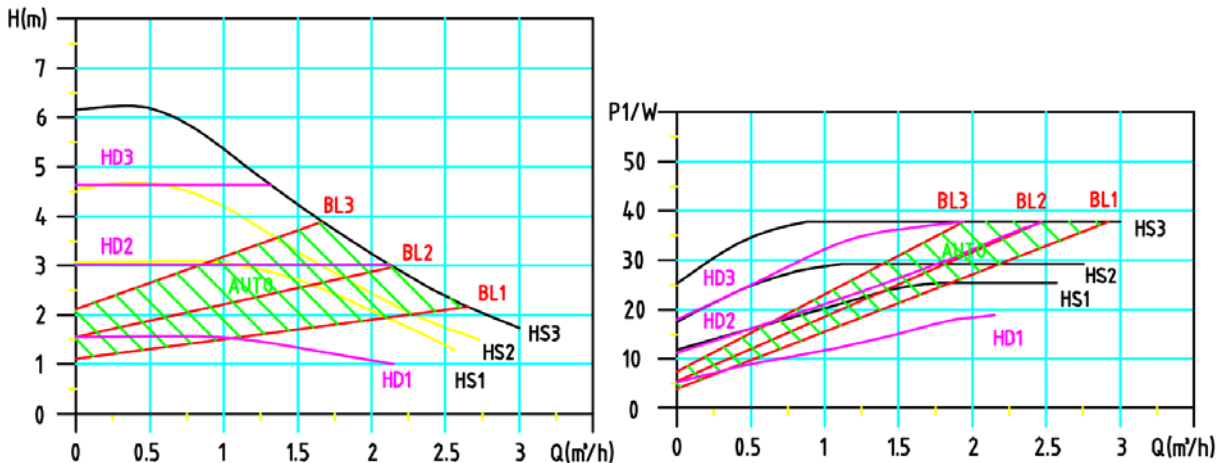

2. 4. 4 Plus XX-7 performance curve

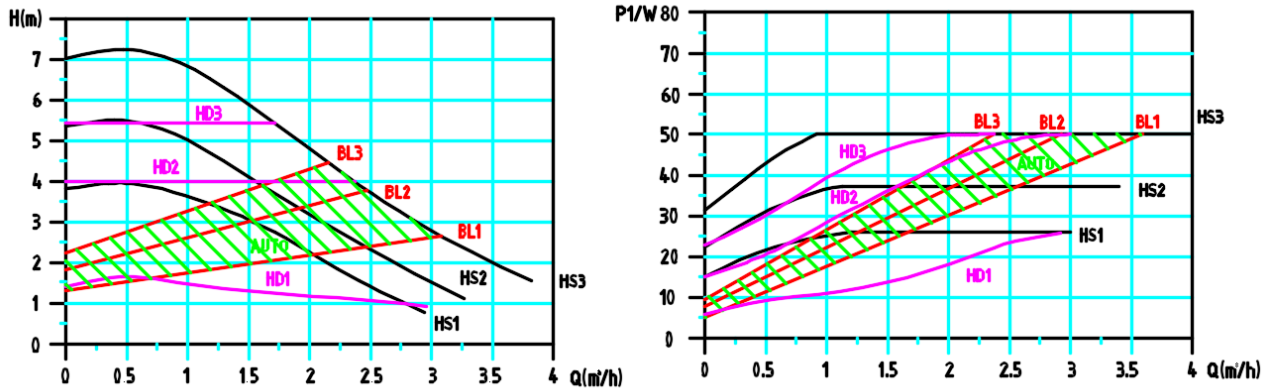

2. 4. 5 Plus XX-7.5 performance curve

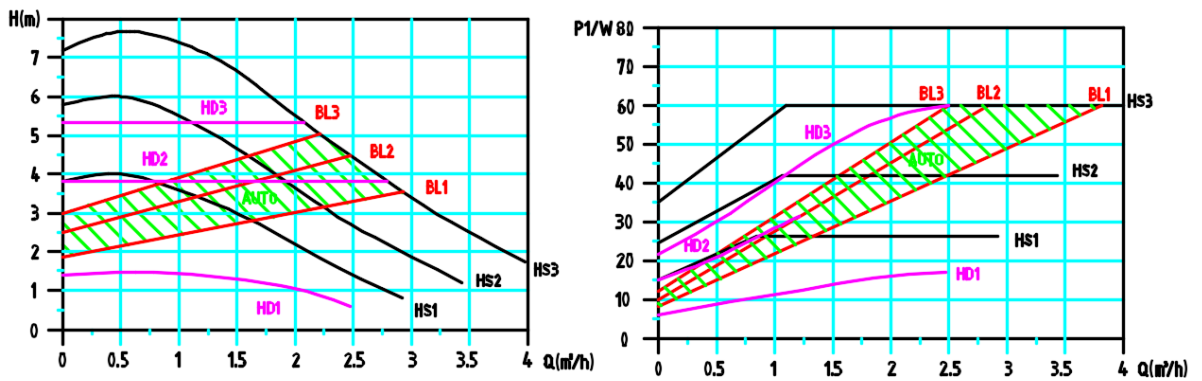

2. 4. 6 Plus XX-8 performance curve

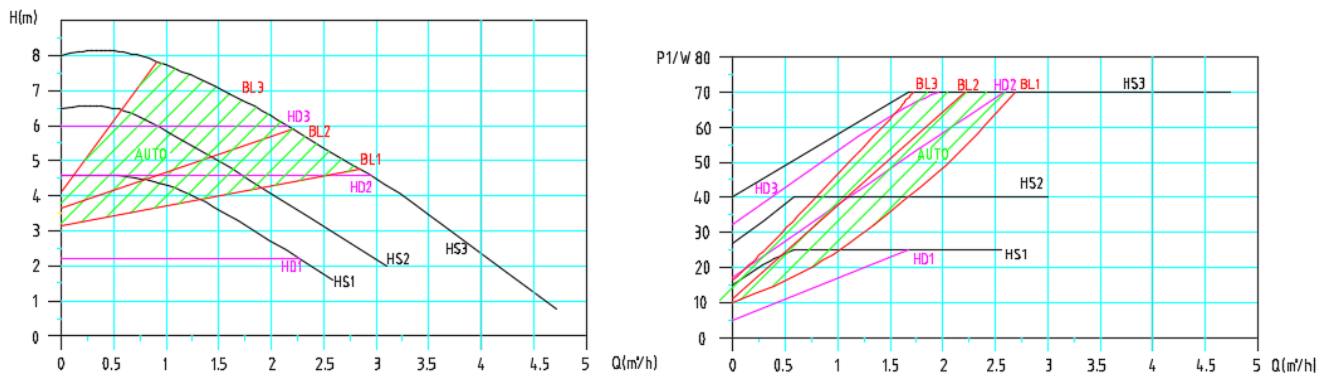

### 3. Product application conditions

Note:When the product is used beyond the scope,the customer needs to discuss with Xihu

#### 3.1 Media requirements

Medium: water or water + glycol ( $\leq 50\%$ ) mixture	Medium temperature: $-20^{\circ}\text{C} \sim 110^{\circ}\text{C}$
PH value of medium: 6.5~8.5	Medium hardness: $\leq 25^{\circ}\text{dH}$
Content of solid impurities in medium: diameter and length direction of solid impurities $\leq 0.1\text{mm}$ , and volume ratio $\leq 0.1\%$ .	

#### 3.2 Service environment requirements

Usage: keep the shaft horizontal	Altitude: $< 1000\text{M}$
Operating ambient temperature: $-30^{\circ}\text{C} \sim +70^{\circ}\text{C}$ (there is no freezing in the pipeline and water pump)	Operating ambient humidity $\leq 95\%$

#### 3.3 Storage environment requirements

Storage ambient temperature: $- 30^{\circ}\text{C} \sim 70^{\circ}\text{C}$ (there is no freezing in the pipeline and water pump)	Humidityof storage environment: $\leq 95\%$
--	---

#### 3.4 Comparison Table of Water Temperature and Inlet Pressure

Liquid temperature	$< 75^{\circ}\text{C}$	$95^{\circ}\text{C}$	$110^{\circ}\text{C}$
Inlet pressure	0.05bar	0.5bar	1.08bar
	0.5 m lift	5 m lift	10.8 m lift

### 4. Product Installation Description

#### 4.1 Nameplate parameters

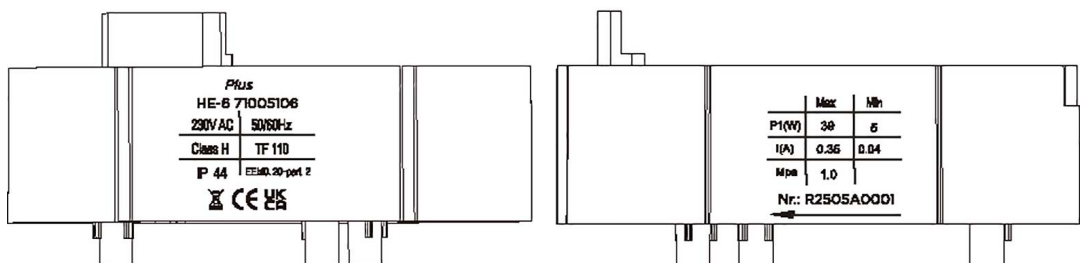

The maximum power and current are changed according to following table

Model	Plus25-4III	Plus25-5III	Plus25-6III	Plus32-7III	PlusXX-7.5III	PlusXX-8III
Maximum power W	25	33	39	52	60	70
Maximum current A	0.25	0.3	0.35	0.45	0.5	0.55
EI	EII ≤ 0.20-Part2					EII ≤ 0.21-Part2

### Product model number



#### 4.2 Product installation direction diagram

When the circulation pump is installed early, the circulation pump shaft must be in a horizontal position, and the allowable installation angle of the circulation pump shaft is  $\pm 5^\circ$ . The installation method of the circulating pump in the system should ensure that there is no large amount of gas in the chamber of the circulating pump to avoid affecting the normal operation of the circulating pump.

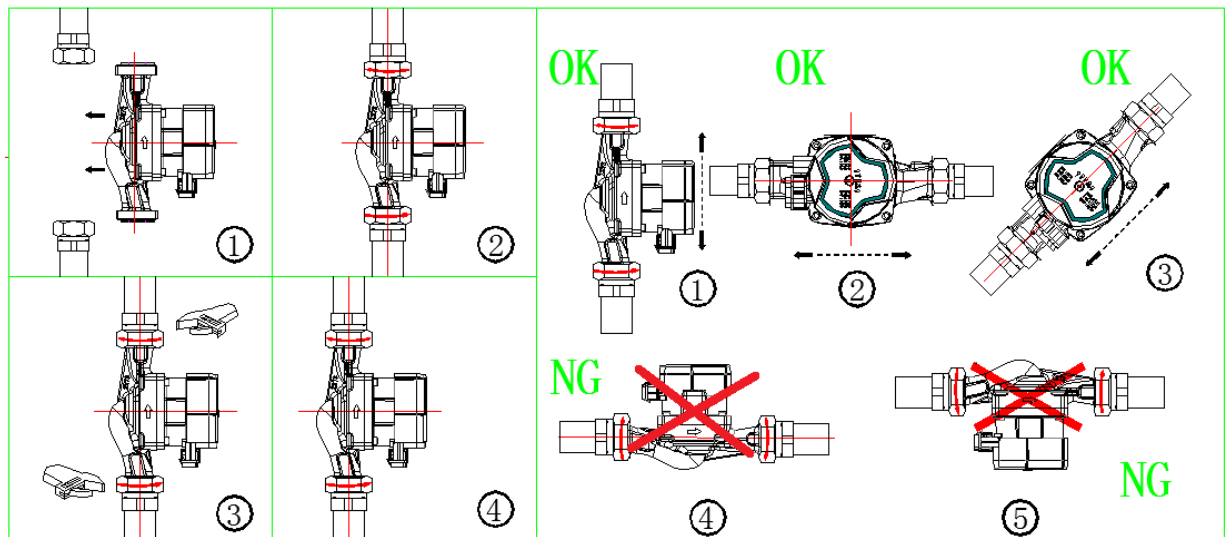

### Terminal box location

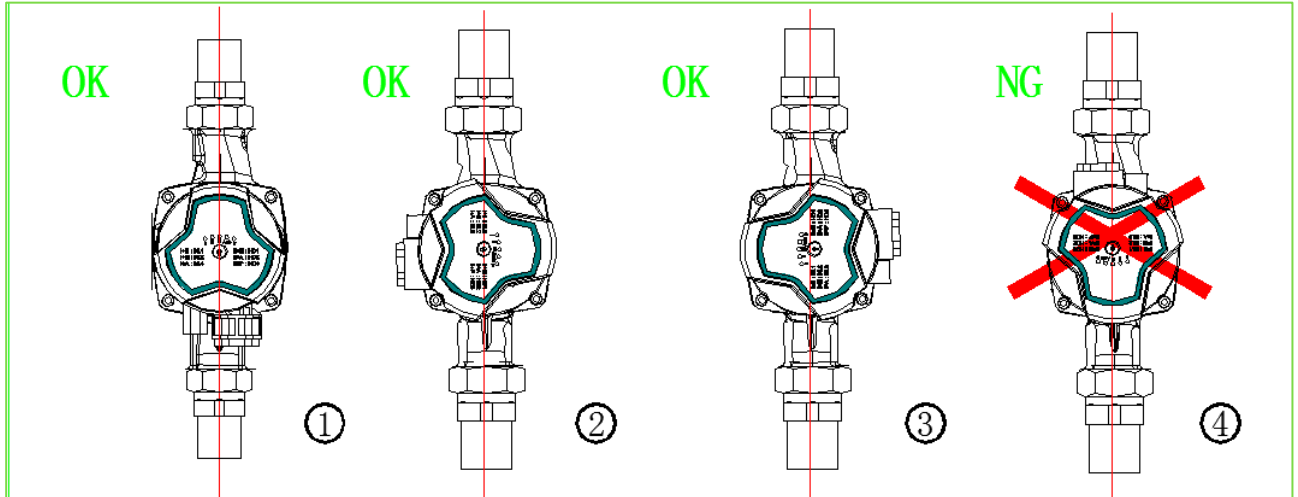

### 4.3 Start and stop of pump

**Starting time:** the starting time of the water pump is less than 3S, that is the time from power on to reaching the maximum speed

**Shutdown time:** the shutdown time of the water pump is less than 1s, that is, the time from power failure to shutdown of the water pump

### 4.4 Illustration of an insulating cotton wrap

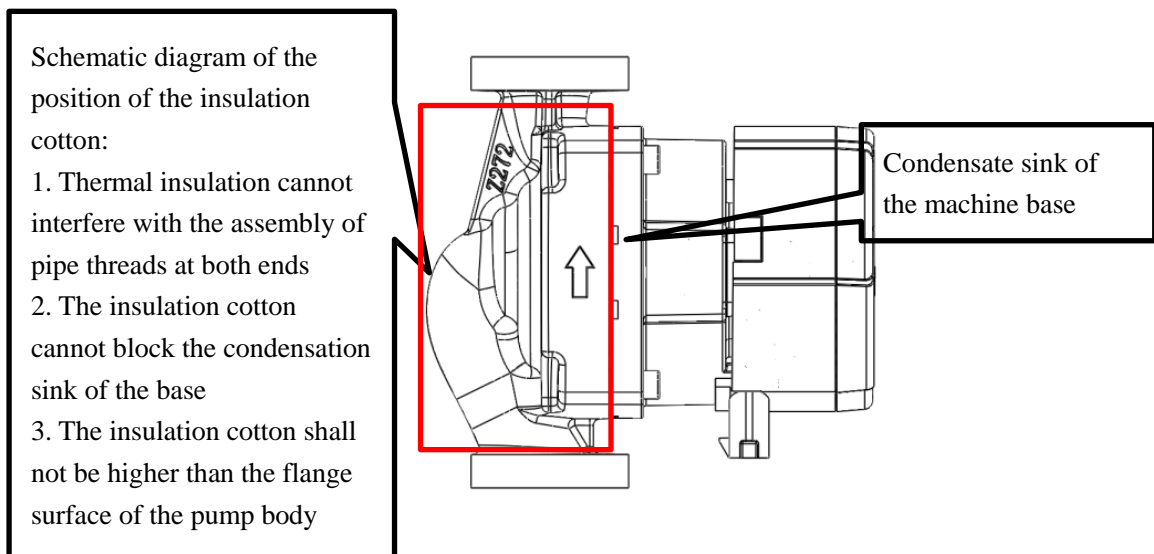

#### 4.5 Panel display diagram explanation

Press the button briefly once to switch the working mode. The default working mode when powered on is Auto. The comparison table between the number of button presses and the working gear of the water pump is shown in the following table

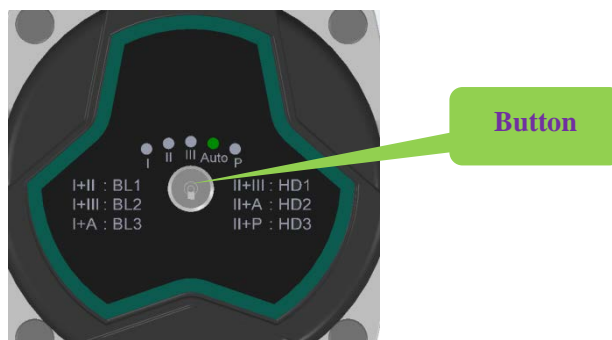

The number of keystrokes	Light area	illustrate	Icon
0	HS3 (Factory settings)	Constant speed high speed	
1	BL1	Proportional pressure at low speed	
2	BL2	Proportional pressure at medium speed	
3	BL3	Proportional pressure at high speed	
4	HD1	Constant pressure and low velocity	
5	HD2	Constant pressure at medium speed	
6	HD3	Constant pressure at high speed	
7	HS1	Constant speed low speed	
8	HS2	Constant speed medium speed	
9	AUTO	Automatically adapts	
/	P	PWM1 control	
		PWM2 control	
Gear Mode Switching Instructions:			

1. The Auto gear is displayed by default.
2. Gear switching: press the button to switch gears;
3. PWM signal switching:
  - 3.1. Conventional mode→PWM1: After the PWM signal is turned on, it will automatically switch into PWM1 mode, disconnect the PWM signal and switch to non-PWM mode, and the gear will be the gear before the PWM signal is turned on (e.g., switch from the third gear to the PWM mode, and when the PWM signal is disconnected, the gear will be restored to the third gear);
  - 3.2. Conventional mode → PWM2: automatically cut into PWM1 mode after turning on the PWM signal, at this time the P file light is on, and then switch to the PWM2 gear by pressing and holding the gear adjustment button 3S, 5 lights are fully on, press and hold the button 3S to switch to PWM1 gear, at this time, the P file light is on, disconnect the PWM signal and cut into the non-PWM mode, and the gear is the gear before the PWM signal is turned on (for example: switch from the third gear to the PWM mode, when the PWM signal is disconnected, the gear will be restored to the third gear);

#### 4.5 Power connection

Power supply: 220~240V AC, frequency: 50/60Hz, power line specifications:3×0.75mm<sup>2</sup>.

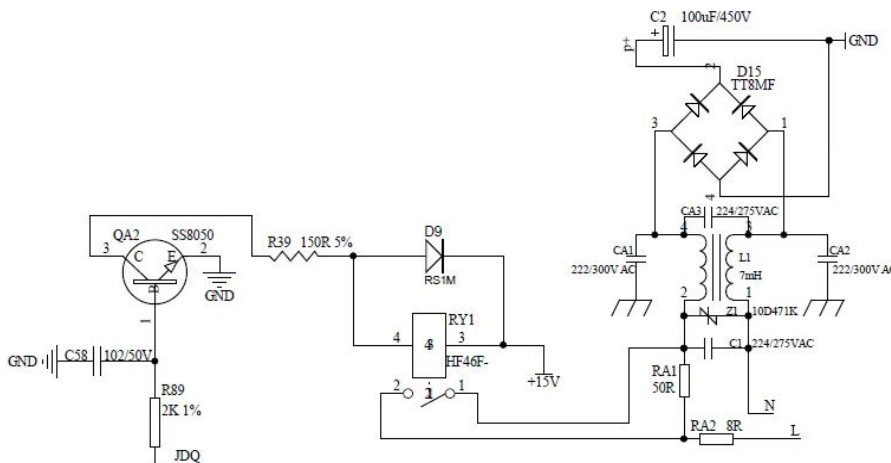

#### 4.7 Signal connection

##### 4.7.1 Signal connection

PWM input signal voltage: 4-24V , PWM input signal frequency: 100-4000Hz;

PWM output signal:pump feedback signal, PWM frequency is 75Hz±5%。

##### 4.7.2 Interface circuit of PWM input signal

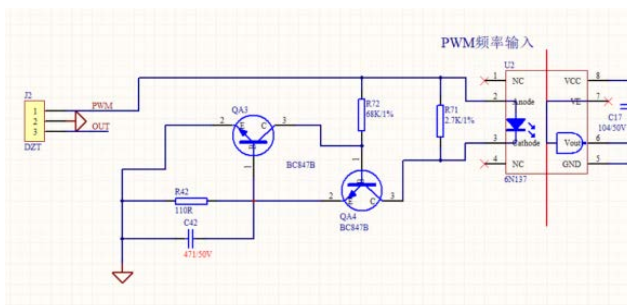

## 4.8 Electric control instructions

### 4.8.1 PWM 1 signal input

Under fixed frequency, different duty cycles correspond to different motor given speed signals. Inverse proportional control mode is adopted. The specific control logic is as follows:

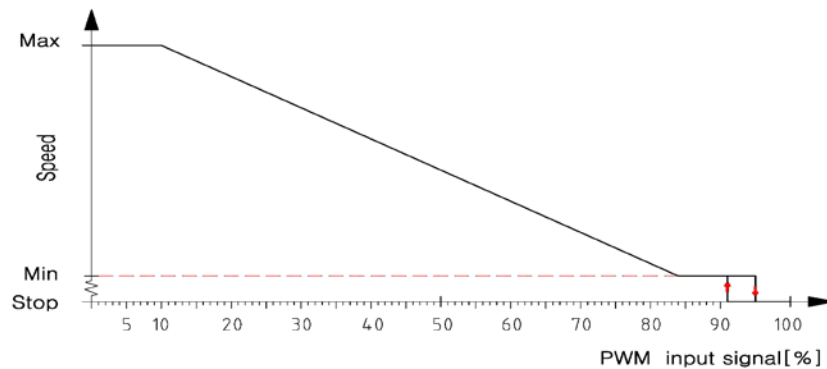

PWM1 Input Signal (%)	Pump Status
$\leq 10$	the pump runs at the highest velocity
$> 10 / \leq 84$	the pump curve will drop from the highest to the lowest
$> 84 / \leq 91$	the pump runs at the lowest velocity
$> 91 / 95$	if the velocity variance point of input signal fluctuates, then it will block the start and stop of the pump according to the principle of magnetic hysteresis
$> 95 / \leq 100$	stand-by, the pump stops
Recognition accuracy	$\pm 1$ (Example: When the PWM input signal is 20%, the actual duty cycle is in the range of 19%-21%)

### 4.8.2 PWM 2 signal input

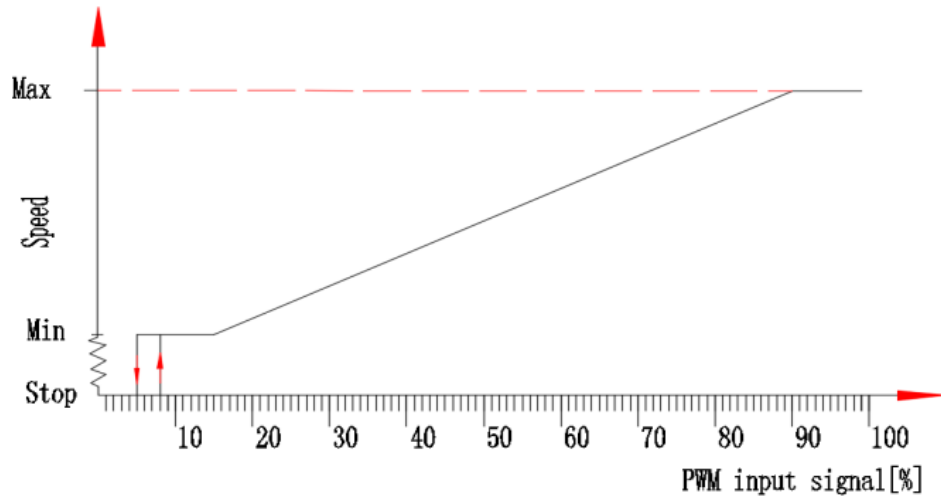

PWM2 Input Signal (%)	Pump status
$\leq 5$	Gear display: 5 lights are fully on, indicating that it is in PWM2 mode Pump status: standby, the pump stops running (the signal line is not connected to the PWM signal, and the pump also stops running)
$>5/ \leq 8$	If the input signal fluctuates near the speed change point, the pump is prevented from starting and stopping according to the hysteresis principle
$>8/ \leq 15$	The water pump operates at the lowest speed
$>15/ \leq 90$	The pump rises linearly from the lowest to the highest
$>90/ \leq 100$	Gear display: 5 lights are fully lit, indicating that in PWM2 mode, pump status: the pump is running at the highest speed
Recognition accuracy	$\pm 1$ (Example: When the PWM input signal is 20%, the actual duty cycle is in the range of 19%-21%)

PWM input signal	parameter
Current isolation in pump	YES
Frequency input	100 – 4000 Hz
Input voltage high level	4.0 – 24 V
Input voltage low level	$\leq 0.7V$
Input current high level	Max 10 mA@100Ohms
Input PWM duty cycle	0 – 100 %
Signal polarity	Fixed changeless
Rise time	$\leq T/1000$

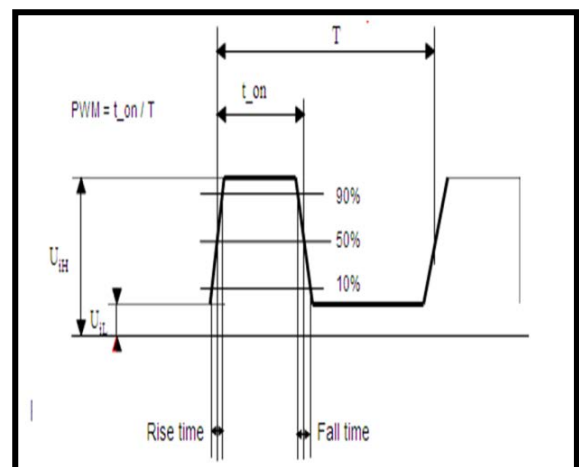

#### 4. 8. 3 PWM feedback

Frequency range:  $75 \pm 5\%$  Hz.

Corresponding relationship between output signal and circulating pump and operating status.

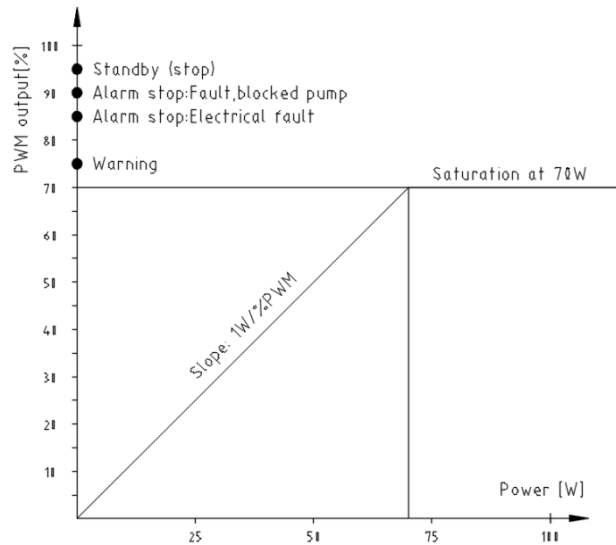

PWM output signal(%)	State	Potential causes
95	Standby (stop)	The pump stops
90	Alarm shutdown, fault (pump stuck) (locked rotor protection)	The water pump does not operate. After the fault disappears, the water pump will operate again. If the fault is not eliminated after 5 restarts, the water pump will not restart again, and it needs to be powered on again.
85	Alarm shutdown, electrical fault (light load protection, phase loss protection, overcurrent protection, over temperature protection, etc.)	The water pump does not run, and the water pump will run again after the fault disappears; Remarks: light load protection and phase loss protection. After the cumulative number of protection reaches 5 times, it will not be restarted, and it needs to be powered on again for operation.
75	Warning (overvoltage protection and undervoltage protection)	The water pump does not operate. In this case, the fault has been detected, but the fault is not critical. It can still work normally after the protection value is restored.
0~70	0-70W (slope 1 W/% PWM) $\pm 1\%$	
Recognition accuracy: $\pm 1$ (Example: When the PWM input signal is 20%, the actual duty cycle is in the range of 19% ~21% )		

#### 4. 8. 4 Fault protection description

**1. Over-voltage protection:** During the power-on test, the detection input voltage is higher than  $270 \pm 10V$ , after 2S it enters the over-voltage protection, the gear I indicator flashes, the pump stops running, when the voltage is restored to  $260V \pm 10V$ , the pump resumes normal operation.

**2. Under-voltage protection:** During the power-on test, the detection input voltage is lower than  $165 \pm 10V$ , after 2S it enters the under-voltage protection, the gear II

indicator flashes, the pump stops running, and when the voltage is restored to  $175V \pm 10V$ , the pump resumes normal operation.

**3. Over-current protection:** When the pump is running, if the hardware current is too large, turn on the over-current protection. The water pump stops working immediately, the gear III indicator flashes, and the water pump restarts after 5s, if the fault is not eliminated, it has been circulating.

**4. Phase loss protection:** when the motor is out of phase, the pump will stop working immediately, the PWM indicator will flash, and the pump will restart after 5s, if the fault is not eliminated, it will be circulated.

**5. Stalled rotor protection:** After the stalled rotor occurs, turn on the stalled rotor protection, the pump stops working, the indicator lights of the I and II gears flash at the same time, and the pump restarts after 5s, if the fault is not eliminated, it has been circulating.

**6. Light load protection:** under HS3 gear, after 10s of power-on operation, start to detect light load protection, power-on operation power is less than 10W and last for 8s, turn on light load protection, AUTO gear indicator flashes, the pump restarts after 5s, after the continuous number of protection reaches 5 times, the pump is completely protected, no longer restarts, and needs to be re-powered.

**7. Over-temperature protection:** When the surface temperature of the IPM module is higher than  $120 \pm 10^\circ C$ , the water pump will be shut down, and the indicators of I and PWM files will flash at the same time. When the IPM surface temperature is below  $100 \pm 10^\circ C$ , the pump resumes normal operation.

**8. Overheat protection:** When the surface temperature of the IPM module is higher than  $110 \pm 10^\circ C$ , the water pump will be reduced to 0.5 times the rated power to operate, and the indicators of I and AUTO gear will flash at the same time, and the temperature will be lower than  $100 \pm 10^\circ C$ , and the water pump will resume normal operation.

## 5. Product testing

### 5.1 Factory inspection

Motor turn to detection	Motor insulation test	Withstand voltage detection
Leakage current detection	Steering detection	Inspection of the tightness of the whole machine
Drive detection	PWM signal detection	NA

## 5.2 Reliability test

High environment temperature and low water temperature runningtest	Low environment temperature and high water temperature runningtest	High temperature environment test
Temperature rise test	High and low voltage starting resistance test	High temperature and humidity test
Aging test	Stall protection durability test	Protection class test
Overvoltage protection durability test	High ring temperature and low water temperature test	Life test
Undervoltage protection durability test	Start/ stop test	/

## 6. Packing method

### 6.1 Single product packaging

carton (1 box of 4 or 8)



### 6.2 Mass production packing

Pallet(number of whole pallet:200)pallet size:length 1155,width 705  
Hight 905

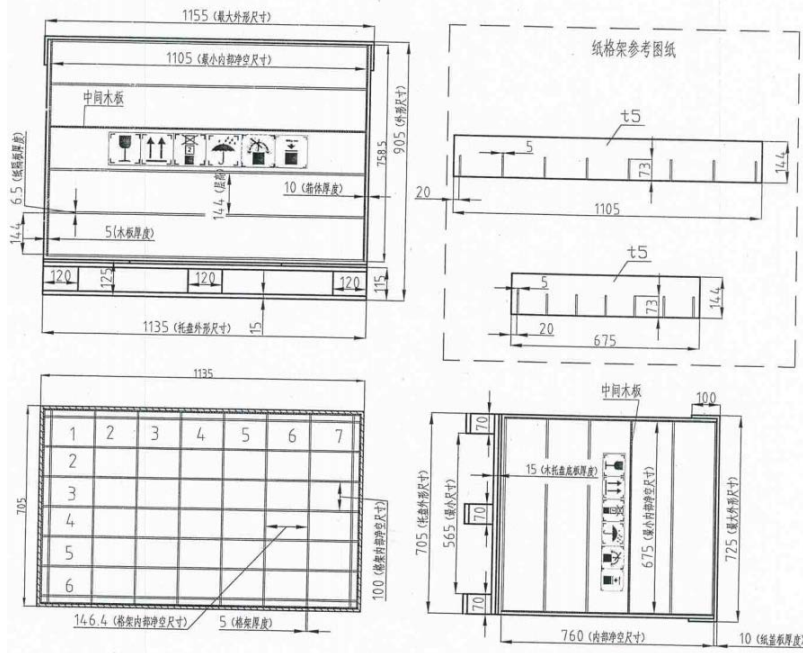

## 7. Instructions for use

### 7.1 Mobile dismantling

The liquid conveyed by the circulation pump may be high-temperature and high-pressure liquid. Before moving or disassembling the circulation pump, the liquid in the system must be drained or the shut-off valves on both sides of the circulation pump must be closed to avoid burns.

### 7.2 Prevention of frost cracking

In winter, if the circulating pump system is not running or the ambient temperature is below 0 °C, the liquid in the pipeline system should be drained to avoid freezing and cracking of the pump body.

### 7.3 Long term non use of circulating pumps

Please close the inlet and outlet water pipe valves of the circulating pump and cut off the power supply of the circulating pump

### 7.4 Motor overheating and abnormalities

Please immediately close the inlet valve of the circulating pump, cut off the power supply of the circulating pump, and contact your local dealer or service center immediately.

### 7.5 Preventing Children from Touching

This product should be placed out of reach of children. After installation, isolation measures should be taken to prevent children from touching it.

#### 7.6 Installation direction of circulating pump

When installing the circulating pump, the shaft of the circulating pump should be kept horizontal, as shown in Chapter 4.2 for specific views.

#### 7.7 Installation Protection

The circulating pump needs to be installed in places that prevent rain, water, and sunlight exposure.

#### 7.8 Water hammer impact

The circulating pump cannot be directly impacted by hard objects, and cannot exceed a 10 kilogram water hammer impact.

#### 7.9 Power connection leads

The motor leads do not have a special anti pulling structural design, please do not directly apply force to avoid wire breakage.

#### 7.10 Prohibit the circulation pump from running out of water

Prevent product wear and tear, generate abnormal sounds, and even burn the machine.

#### 7.11 Pumped Liquid

The medium conveyed by the circulating pump should be a thin, clean, non corrosive, and non explosive liquid, without any solid particles, fibers, or mineral oil. The circulating pump is prohibited from conveying flammable liquids outside of the specifications. If the viscosity of the circulating pump is high, the performance of the circulating pump will decrease. Therefore, when selecting a circulating pump, the viscosity of the liquid medium being transported should be considered.

#### 7.12 Scale inhibitors

It is recommended to use Sentinel X100 scale inhibitor for the circulating pump, with a ratio of water 100: scale inhibitor 3.75.

#### 7.13 Power grounding

The power plug should be strictly grounded, and the grounding pin of the plug should be reliably connected to the grounding hole of the power socket. It is not allowed to change the power grounding without authorization.

#### 7.14 Maintenance precautions

When the circulating pump is working, if the position of the circulating pump is adjusted or there is a movement that touches the circulating pump, the power should be cut off first to prevent accidents.

## 8. Common fault causes and solutions

fault	Cause of occurrence	Exclusion method
Circulating pump	Whether the power supply is disconnected	Check the power connection and determine

cannot start	and the voltage is normal	the voltage
	The fuse in the device is burnt out	Replace the fuse
	Current/current controlled circuit breaker disconnection	Connect the circuit breaker
	Circulating pump malfunction	Replace the circulating pump
	Voltage too low	Check if the power supply is within the specified range
	Circulating pump blocked (stuck)	Remove impurities
Pump running but not under pressure	There is gas in the system	Exhaust the system
	Excessive flow	Reduce the inlet pressure of the circulating pump
There is noise in the circulating pump	There is gas in the circulating pump	System exhaust
	There are impurities and friction in the pump	Clean
	Wear of wiping ring, wiping screen sleeve or bearing mechanical seal	Replace the circulating pump
	Water pump cavitation	Reduce the outlet valve or increase the inlet pressure
Insufficient traffic	The performance of the circulating pump is too low	Selection of high-power circulating pumps
	Pipeline blockage	Clean the pipeline and filter
The circulation pump cannot be controlled	No signal on the signal line	Poor cable contact, reinstall or replace

## 9. Disclaimer

This specification is proposed by Anhui Shinhoo Canned Motor Pump Co., Ltd. Shinhoo has the right to make changes to any matters not covered in the specification. The product should be used within the conditions and scope of use specified in the specification. If it exceeds the conditions and scope of use, it may cause damage or damage to the product. When the usage conditions exceed the product usage conditions, please consult with Shinhoo in advance.

The matters not covered in the circulating pump specification and related explanations are subject to the final interpretation rights of Shinhoo.

**Annex**

a. Assembly drawing and main part material table

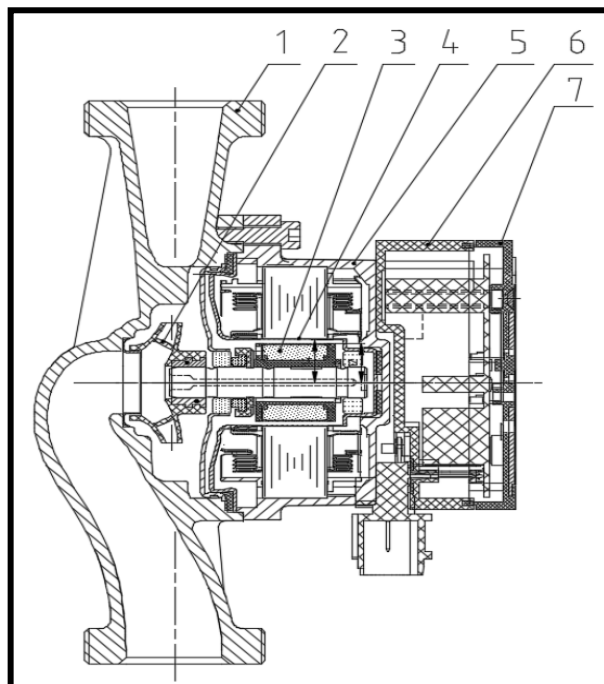

	Part	Part material	Note
1	Pump housing	Cast iron	/
2	Impeller	Composite material	/
3	Rotor assembly	assembly	/
4	Shielding sleeve assembly	SUS304	/
5	Base	aluminum alloy	/
6	Box holder / PCB	Composite material / assembly	/
7	Lid	aluminum alloy + Composite material	/

## b. Installation dimension drawing

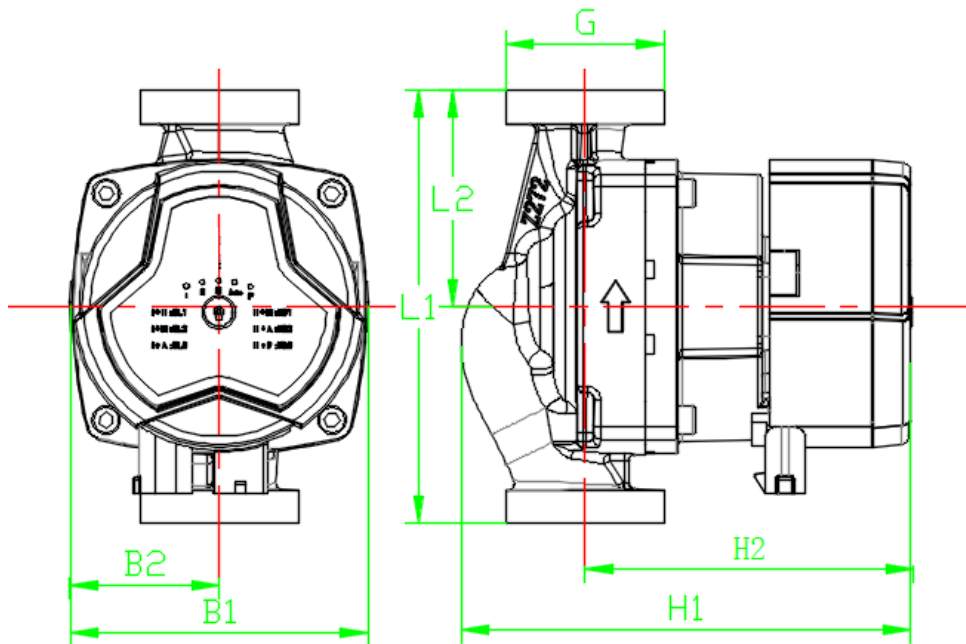

Type	B1	B2	L1	L2	H1	H2	G
Plus 20-X /130	90	45	130	65	135	90	1"

Plus 25-X /130	90	45	130	65	135	90	1 1/2"
Plus 25-X /180	90	45	180	90	135	90	1 1/2"
Plus 32-X /180	90	45	180	90	135	90	2"
Note	X: 4、5、6、7、7.5、8						

c. Power interface

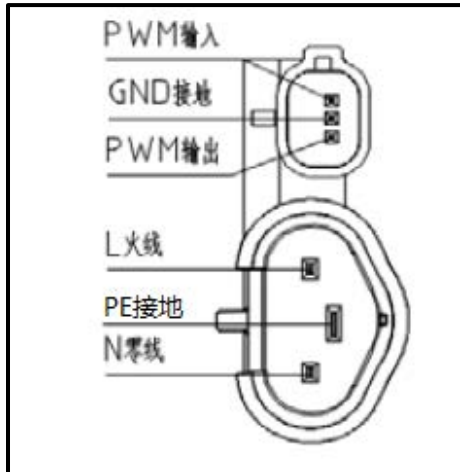

**Warning:**

The Pump must be connected to the ground wire.



d. Power Line Accessories Drawing

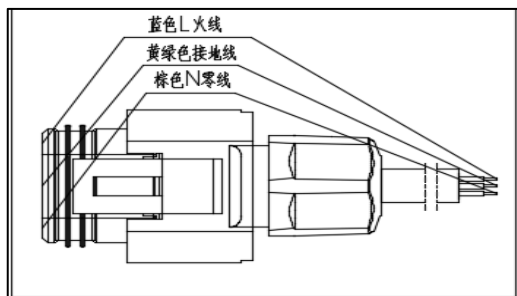

e. Signal Line Accessories Drawing

