



Heat Pump Water Heater Operation and Installation Manual



Model

CURV-HP80M8

CURV-HP110M8

CURV-HP150M8



Please read this manual carefully prior to your use of this water heater.

The appearance of the water heater given in this manual is for reference only.

Don't install and use the product outdoors.



EN 12897:2016

Contents:

Page 2 – Cylinder Schematic diagram

Page 3 – Airflow & Ducting

Page 4 – Mechanical Installation Diagram

Pages 5-7 - Electrical Installation Instructions

Page 8-10 – Operation & Functions

Page 11 – Wi-Fi Connection & Installer Settings

Page 12 - APP Status

Page 13-14 - Checking and Maintenance

Page 15-18 – Fault Codes & Information

Page 19-23 – Flow Diagrams

Page 24-32 – Replacement Parts & Fault Finding

Page 33-38 – Temperature Sensor Resistance Settings.

Description of parts and components

Exploded view

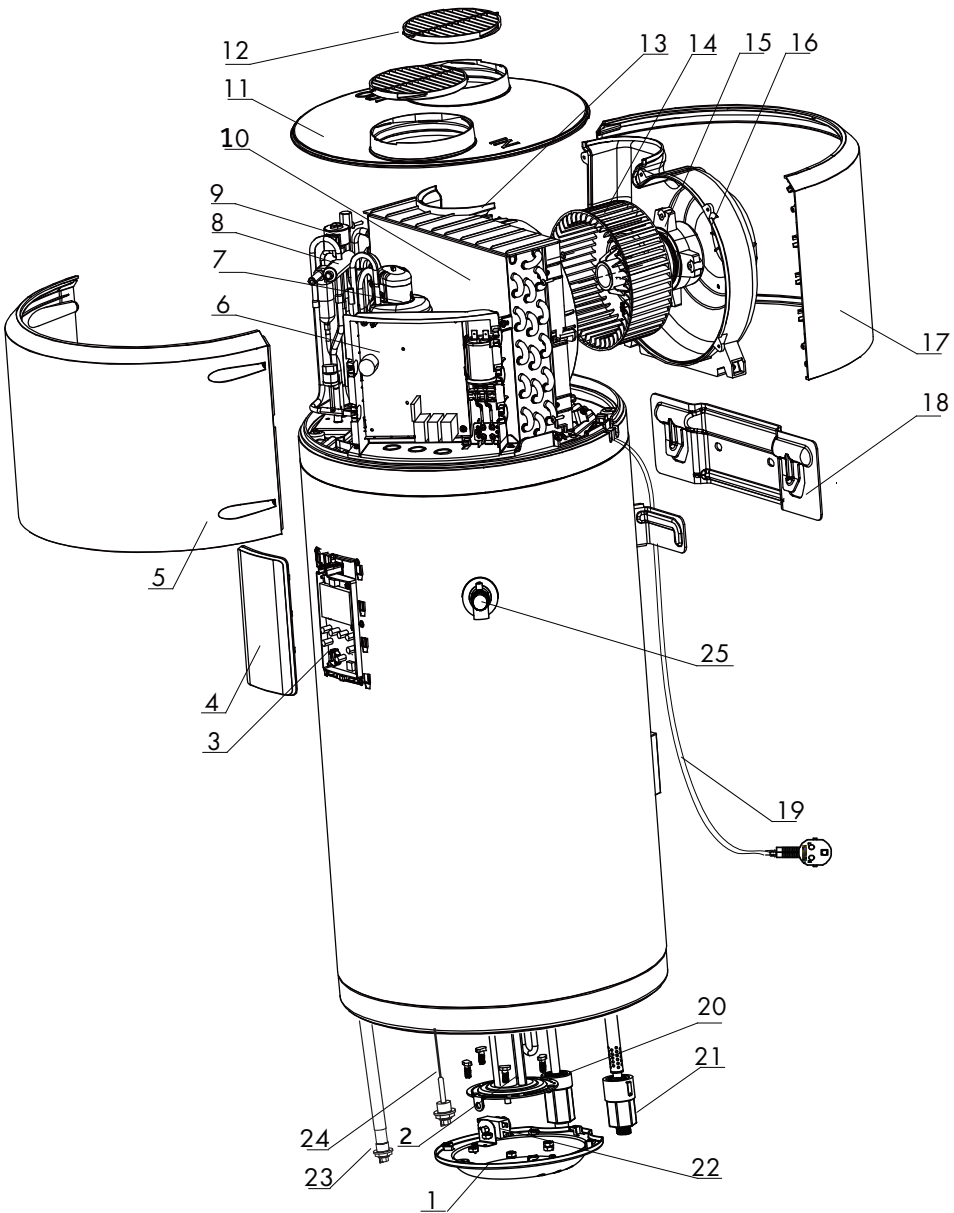





S/N	Description
1	Electric cover
2	Electric heater
3	Display panel
4	Cover for display
5	Front cover
6	Controller panel
7	Compressor
8	Four-way valve
9	Electronic expansion valve
10	Evaporator
11	Top cover
12	Air grille
13	Air channel - front
14	Fan
15	Motor
16	Air channel - back
17	Back cover
18	Support plate
19	Power cord
20	Pipe for water outlet
21	Pipe for water inlet
22	Thermostat
23	Insulated magnesium rod
24	Electronic anode
25	Safety Valve

Installation introduction

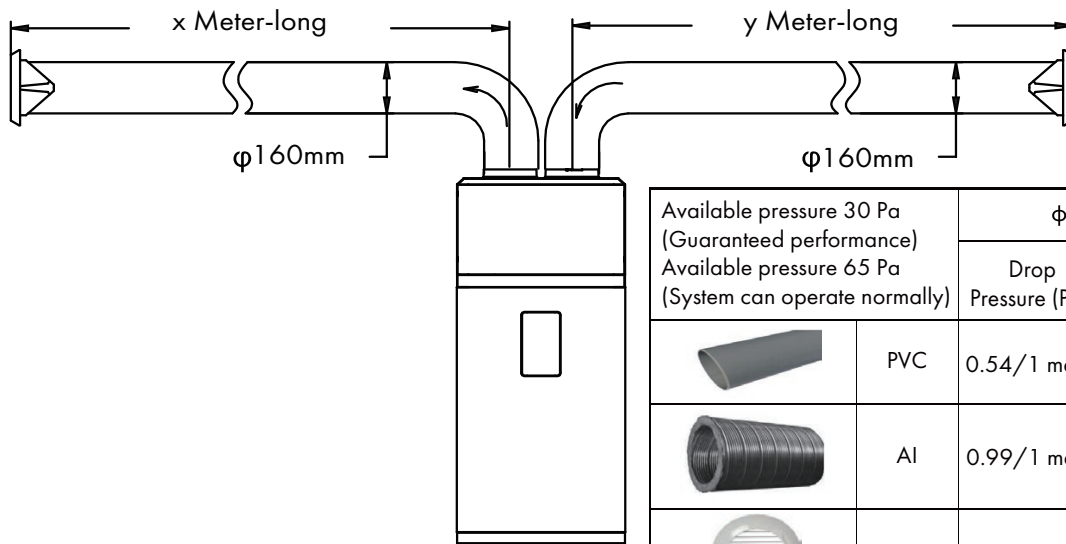
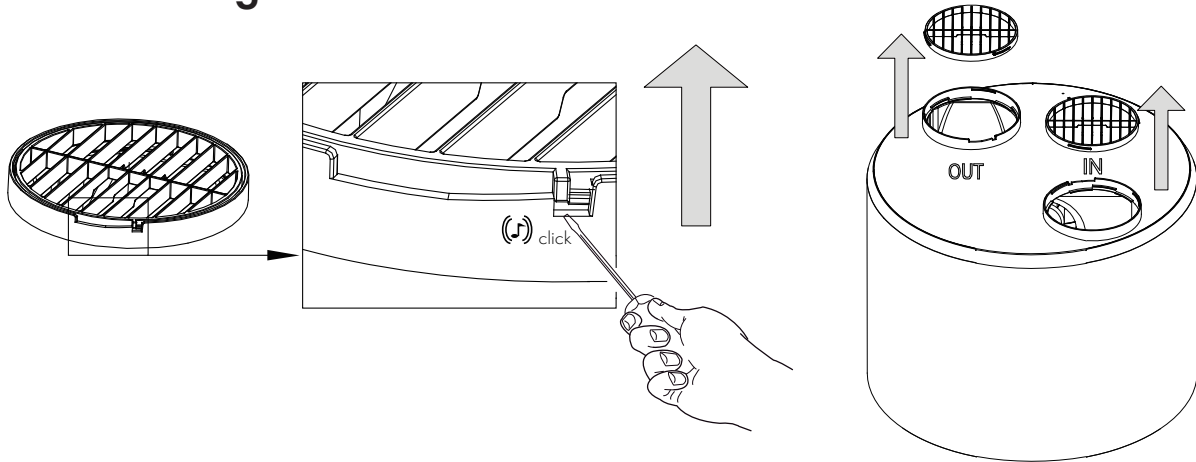
Air connection

- Remove air grille first



Available pressure 30 Pa (Guaranteed performance) Available pressure 65 Pa (System can operate normally)		φ160mm	
		Drop Pressure (Pa)	Equivalent 1m-long
	PVC	0.54/1 meter	1.00
	Al	0.99/1 meter	1.83
	Grille	1.23/unit	2.28
	90° PVC	1.62/unit	3.00
	90° Al	1.27/unit	2.35

Installation suggestions:

$x + y < 40$ m (PVC)

$x + y < 22$ m (Al)

- Install diameter 160mm duct.
- Pressure drops from duct must be lower than or equal to the static pressure of the fan.
- If the pressure drops out of range, the performance of the appliance will be impaired.

In order to ensure the performance of the product, it is recommended that the total length of the air duct should not exceed 22m(Bellows tube) and 40 m (Smooth tube). In this case, the performance will not be guaranteed.

It is recommended that an air grille with a mosquito net be installed at the air inlet of the air guide duct. **The ventilation area shall not be less than 150 cm².**

Installation introduction

Pipeline installation diagram

Installation A

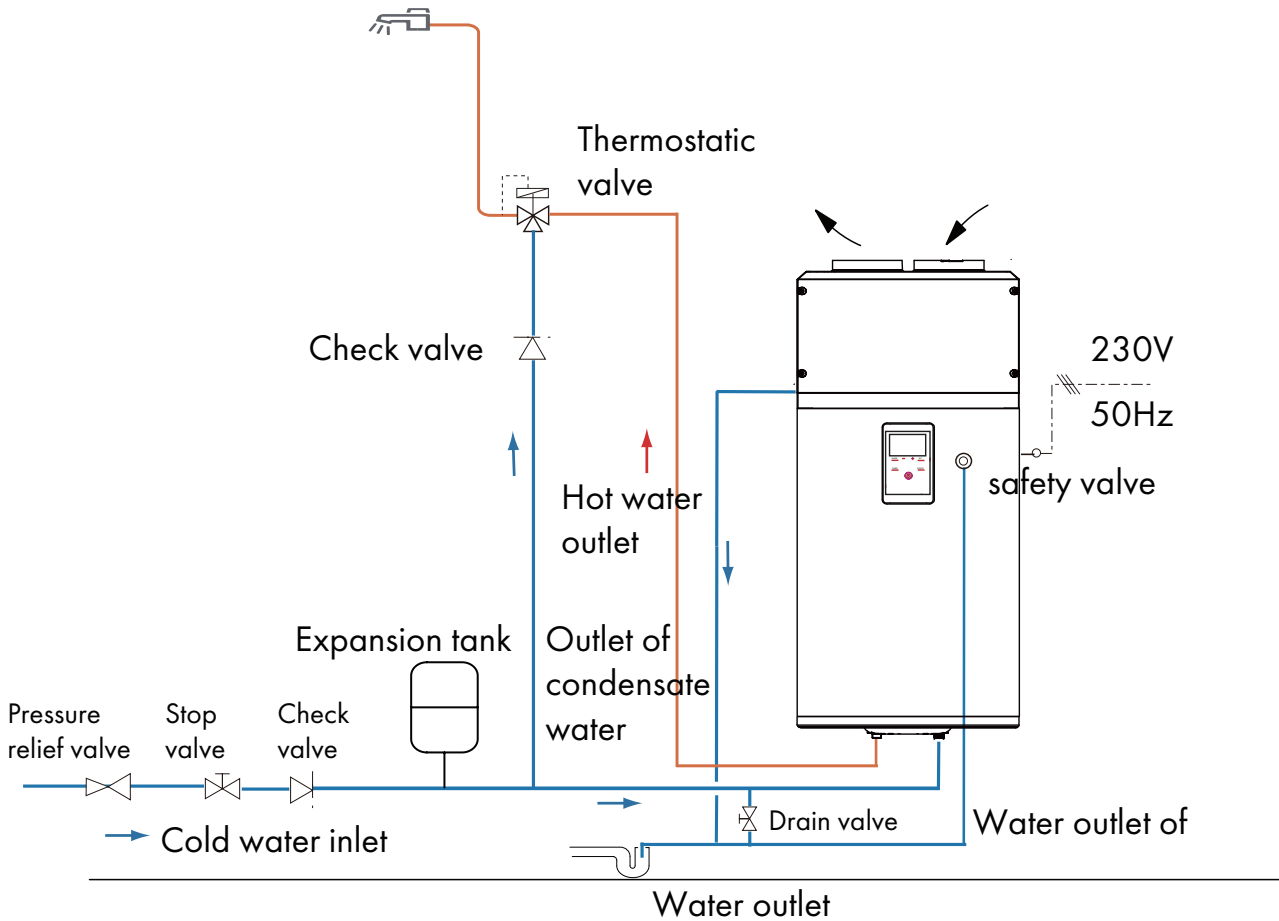

Pressure relief valve, thermostatic valve, stop valve, check valve, expansion tank and combination valve are not included in the accessories, please select proper Fittings in local market;

Installation introduction

Electrical connections precautions

Installation A



WARNING

- Only qualified professionals may carry out electrical connections, always with the power off.
- The earthing shall comply with local standards.
- Water heaters shall be equipped with a dedicated power line and residual current circuit breakers. The action current shall not exceed 30 mA;
- The ground line and the null line of the power supply shall be separated entirely. Connecting the null line to the ground line is not allowed.
- Parameter of the power line: $3 \times 1.5\text{mm}^2$ or more.
- If a power cable is damaged, it shall be replaced by qualified professionals to avoid risks.
- In the case of places and walls where water may be splashed to, installation height of a power socket shall not be less than 1.8 m, and it shall be ensured that water would not be splashed on these places. The socket shall be installed out of children's reach.
- The phase line, zero line and ground line inside a power socket used in your home shall be wired correctly without any wrong positioning or false connection, and internal short circuit shall be avoided. Wrong wiring may cause fire accidents.

Connection to a PV system

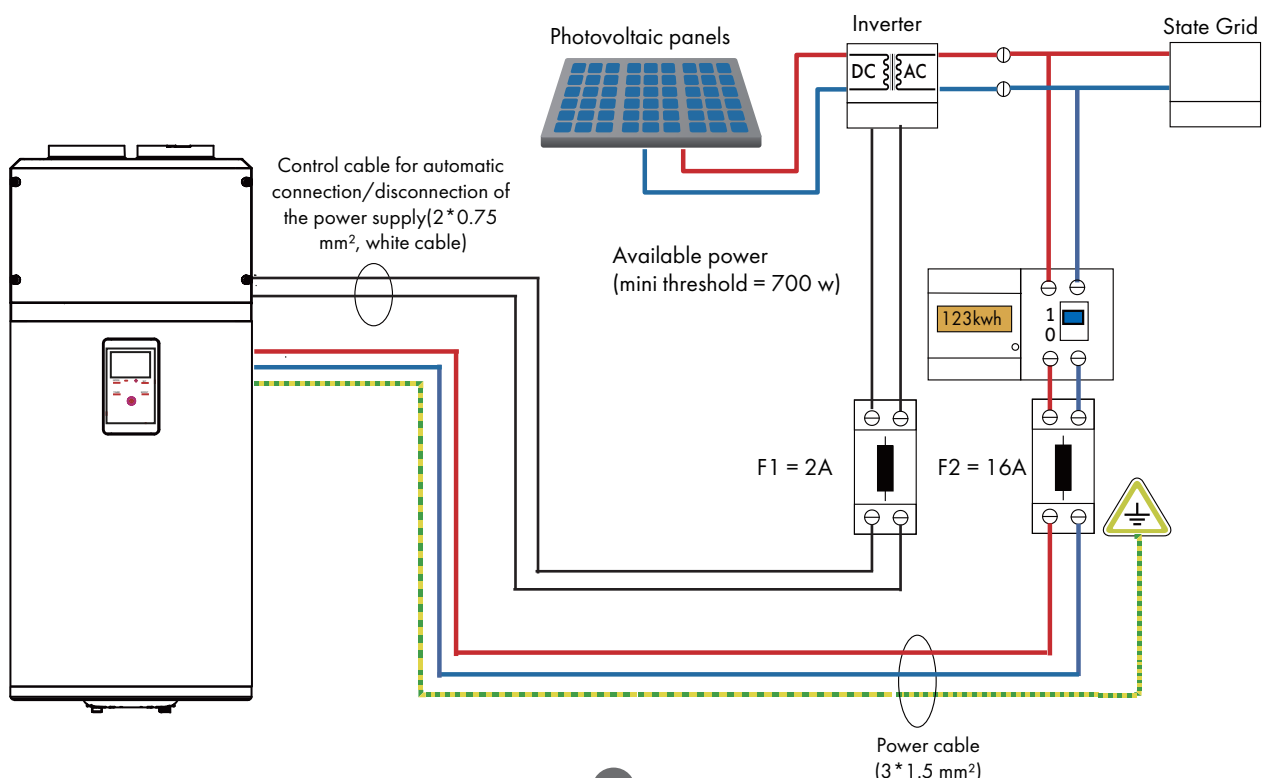

Installation introduction

HC/HP power signal wire connection

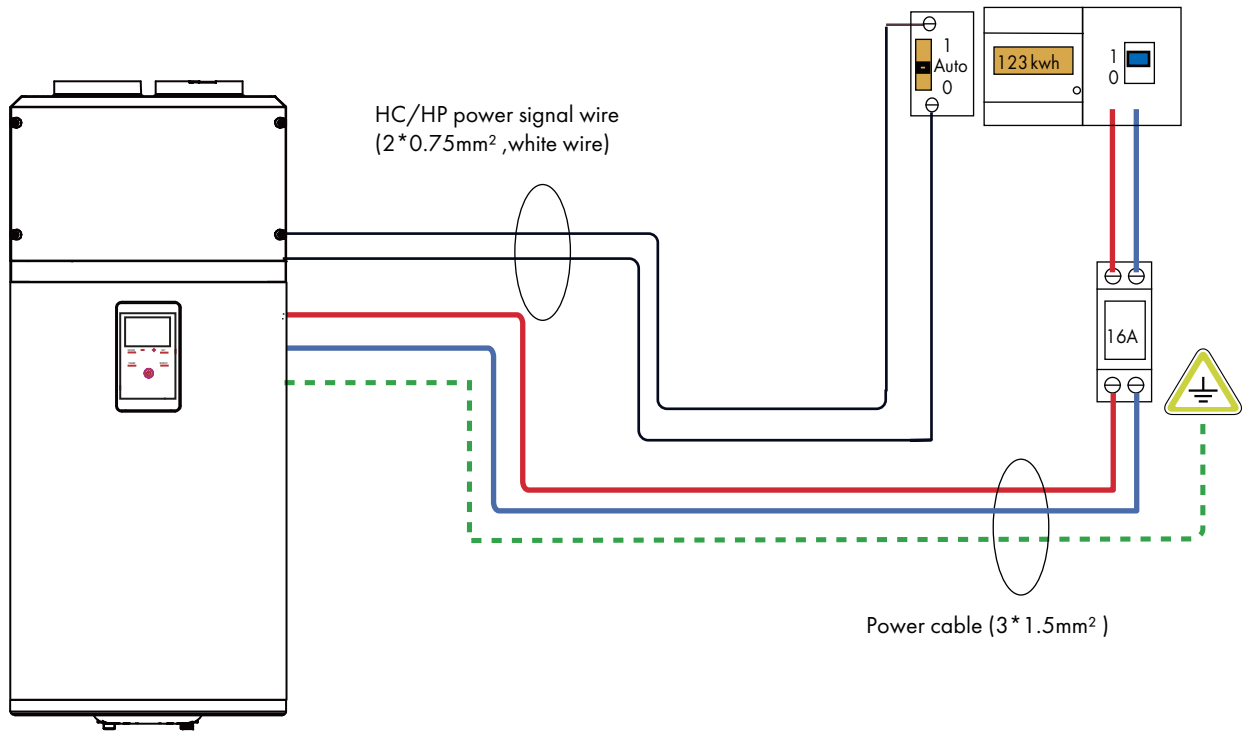

SG signal wire connection

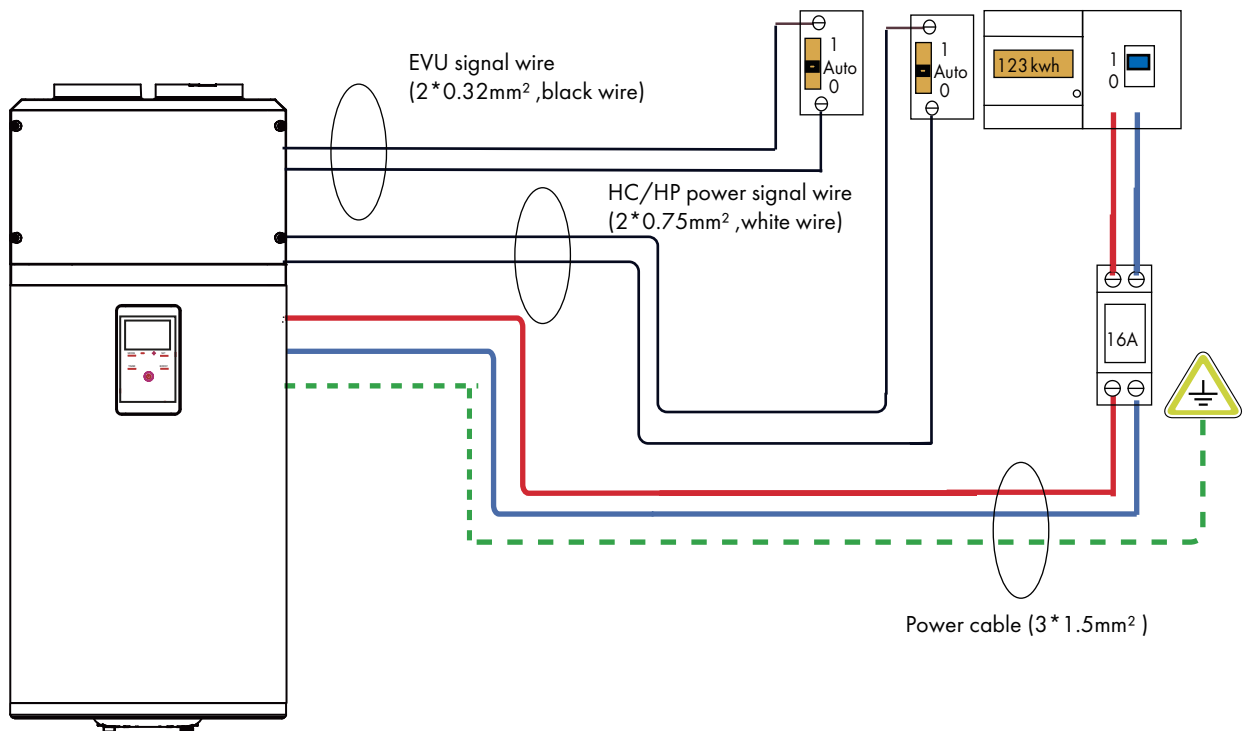

Installation introduction

Wiring diagram

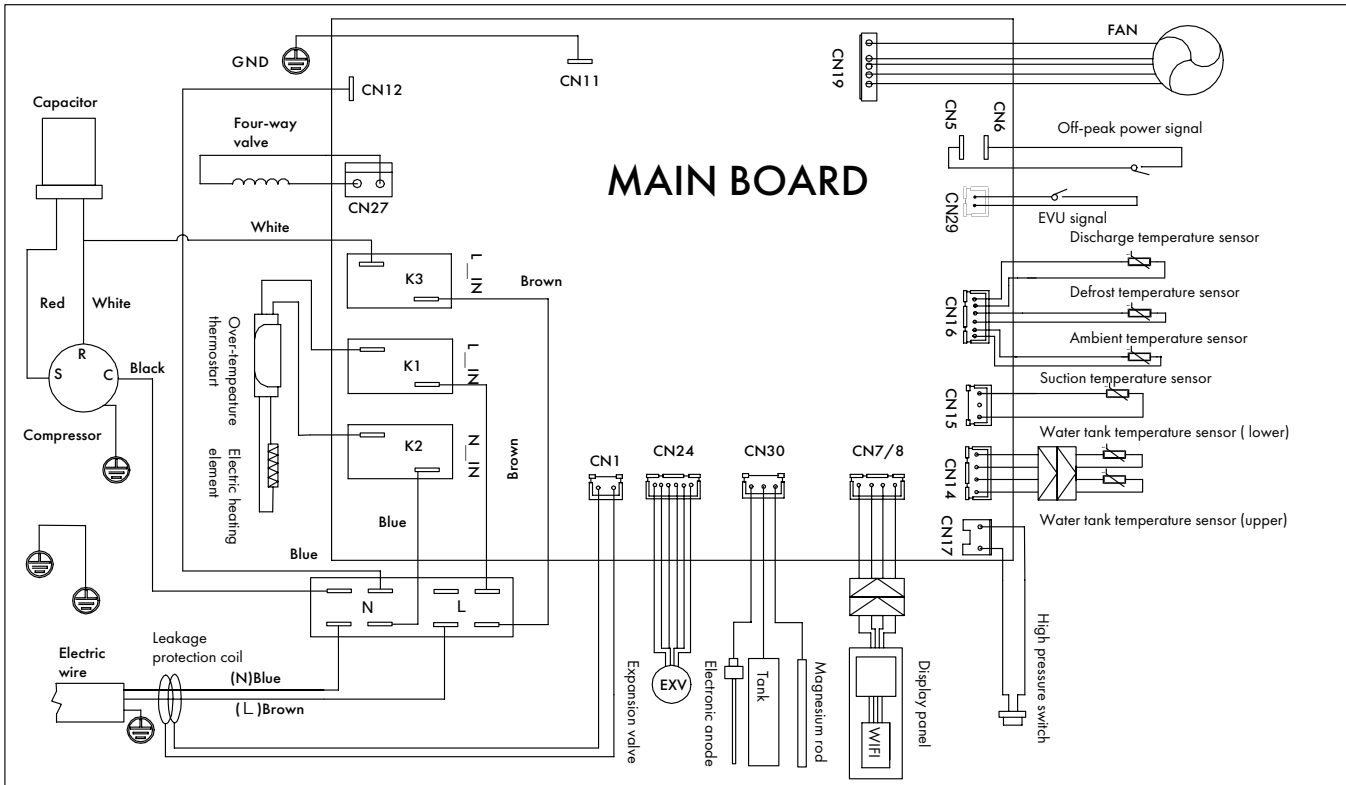

Commissioning

Installers shall use checking list for trial operation of water heaters as per the user manual and make ✓ in .

- Electrical wires are fixed securely?
- Water drain pipes are connected correctly?
- Ground wires are connected securely?
- Supply voltage conforms to relevant electric codes?
- The control panel works well?
- All noises are normal?
- The water tank has been connected with dedicated pressure relief valve (TP valve) and check valve?
- Materials for hot/cold water pipes conform to requirements of use of hot/cold water?
- After the water system is completed, the water tank is filled with water? Is there water drained out of the water outlet of the hot water pipeline?
- After the water pipe of the water system is filled, check the whole water pipeline. There is no leakage?
- After the water system is filled with water, is there water flowing out after pressure is relieved via the automatic safe pressure relief valve?
- After the water system is filled with water and after leakage check, all outdoor water pipelines are applied with heat insulation treatment?
- The drain valve, drain pipe and pressure relief valve drain pipe of the water tank have been connected to the sewage system and the drainage can be carried out well?

Operation and functions

Display

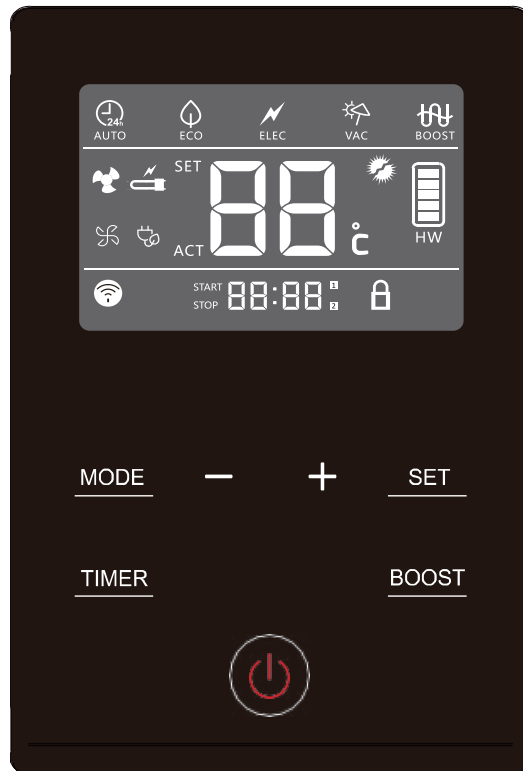





Functions & Protections

- A. Electrical leakage protection
The control system of this machine features an electricity leakage protection function.
- B. 3-minutes protection
When starting the machine after electricity input, the system will start after approximately 3 minutes, which is considered to be normal. When restarting the machine immediately after shutdown, the system goes into the protection mode and starts after approximately 3 minutes, which is considered to be normal.
- C. Automatic defrosting function
The defrosting mode is automatically activated if the outdoor temperature is too low and after the compressor already runs continuously for a certain period.
- D. Overload protection
The working load of the compressor will be heavy if temperature is high in summer. In order to meet hot water requirements of users and to lengthen service life of the compressor, this product automatically adjusts the fan speed to ensure reliable operation of the compressor.
- E. Anti-freezing function
The heat pump starts heating to avoid freezing of the water tank if the temperature in the water tank is too low.
- F. The default temperature setting is 56°C.

Function Introduction

Installer Settings

- To open the installer settings, press  switch off the system, then press  and **SET** at the same time for 5 seconds.
- When the menu is open, press  or  to change the value of the settings.
- Press **SET** to confirm the settings.
- Press  to close the menu.

Parameters	Description	Factory setting	Adjustment range
LP 01, 02 03, 04	<u>Off-peak logic type</u> <ul style="list-style-type: none"> - In four ways using heat pump, should set in the installer settings - 01 Disable function; - 02 switch signals by power companies. - 03 PV signal. - 04 SG signal. 	01	01, 02 03, 04
LL NO, NC	<u>Off-peak signal type</u> <ul style="list-style-type: none"> - When you use off-peak time clock control, first determine the type of signals, Only allow professional installers to operate. - NO corresponds to normally open signal, closed effective - NC corresponds to normally closed signal, open effective - If LP is set to 04, LL can only be set to NO. 	NO	NO, NC
LA 01, 02	<u>Heating method</u> <ul style="list-style-type: none"> - 01: When there is a signal, immediately change the target temperature to set the temperature corresponding to the trough signal, heating according to the initial or thermal insulation heating starting condition, when there is no signal, execute the current setting mode heating logic. - 02: When there is a signal, change the target temperature only within the heating time of the current setting mode, and determine the heating condition (if the current setting mode is set to ECO mode for timed heating, the signal comes during the non-heating period, the target temperature does not jump, and the device does not heat) to determine whether there is no heating signal, and execute the heating logic of the current setting mode. - This parameter is valid only when the LP value is not 01. If LP is set to 04, LA can only be set to 01. 	01	01, 02
Lb 55-75	<u>Target temperature when PV/SG/HC signal is active</u> <ul style="list-style-type: none"> - The temperature setting is adjustable between 55°C and 75°C. - This parameter is valid only when the LP value is not 01. If LP is set to 04, LA can only be set to 01. 	65	55-75
LC 01, 02 03	<u>Heat source selection in PV/SG/HC function</u> <ul style="list-style-type: none"> - 01 Compressor and electric heating work at the same time. - 02 The compressor shall be started first. When the system does not meet the operating conditions, the electric heating can be started. - 03 Only electric heating is operated. - This parameter is valid only when the LP value is not 01. If LP is set to 04, LA can only be set to 01. 	02	01, 02, 03

Installer Settings

Parameters	Description	Factory setting	Adjustment range
AL ON, OFF	<u>Sterilize</u> - This parameter is the switch of sterilization function. - Every once in a while, heat all domestic hot water to 60~75 °C	ON	ON, OFF
AH 60-75	<u>The sterilization target temperature</u> - The sterilization target temperature can be adjusted between 60 and 75 °C	65	60-75
Ad 07, 30 ONCE	<u>Sterilization interval</u> - Sterilization interval can be 7 days, 30 days, only once effective, choose one of the three 07,30,once.	07	07,30, ONCE
AL 00-23	<u>Start time of sterilization</u> - Start sterilization at the set time, only hours can be set.	00:00	00:00-23:00
AA 5-15	<u>Compressor maximum continuous working time</u> - If the maximum continuous working time of the compressor more than Set Time, start auxiliary power.	12	5-15
bt 5-15	<u>Average water temperature starting return difference</u> - When the actual average water temperature is 10°C lower than the set temperature, the heat pump will start again, and the adjustment range is 5-15°C.	10	5-15
bU 5-15	<u>Upper water temperature starting return difference</u> - When the actual upper water temperature is 5°C lower than the set temperature, the heat pump will start again, and the adjustment range is 5-15°C.	5	5-15
FS 00, 01 02	<u>Fan speed function</u> - When the unit is connected with a long air duct resulting in insufficient air volume, the function is used according to actual needs - 00: Disable function - 01: V1 gear (fan speed 750 RPM) - 02: V2 gear (fan speed 800 RPM)	00	00,01,02

Installer settings & WIFI connection

WIFI connection

Your appliance can be connected to your home wireless network and operated remotely using the app. Getting started:

- Ensure your home Wi-Fi network is turned on and that the device is powered on.
- Turn off the device, then press and hold the "-" button to enter the distribution network status. At this point, the Wi-Fi icon will start flashing.

Step 1

Download the CURV Smart life app on the stores, search "CURV Smart App"



Step 2

Create your account on the CURV Smart App or log in if you already have an account.

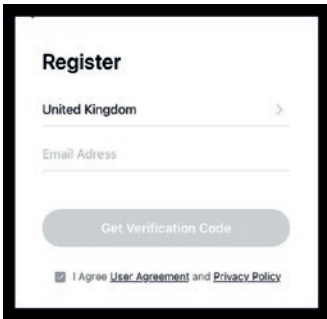

1. When the download is finished, click 'Create New Account'.
2. Enter your email address and press 'Get Code'.
3. You will receive an email with a verification code (If it doesn't appear in your inbox, check your spam/junk folder.)
4. Set your password and click 'Done' to finish.

Add a device

- After logging in, If no devices are currently bound, you can click "Add Device", or tap the "+" icon in the top-right corner to add a device.
- When powered on for the first time, the device will automatically emit a hotspot. Alternatively, you can long-press the power button after turning off the device to enter pairing mode and activate the hotspot. At this point, the APP will display a corresponding hotspot animation. Tap to add the device. Alternatively, scan the QR code on the device and follow instructions on screen.
- Select the target WiFi (choose a 2.4G network), enter the password, and click "Next" to proceed.
- Enter WiFi name and password, and the device will initiate the WiFi pairing and binding process. Once successfully bound, click "Confirm" to access the device control page.

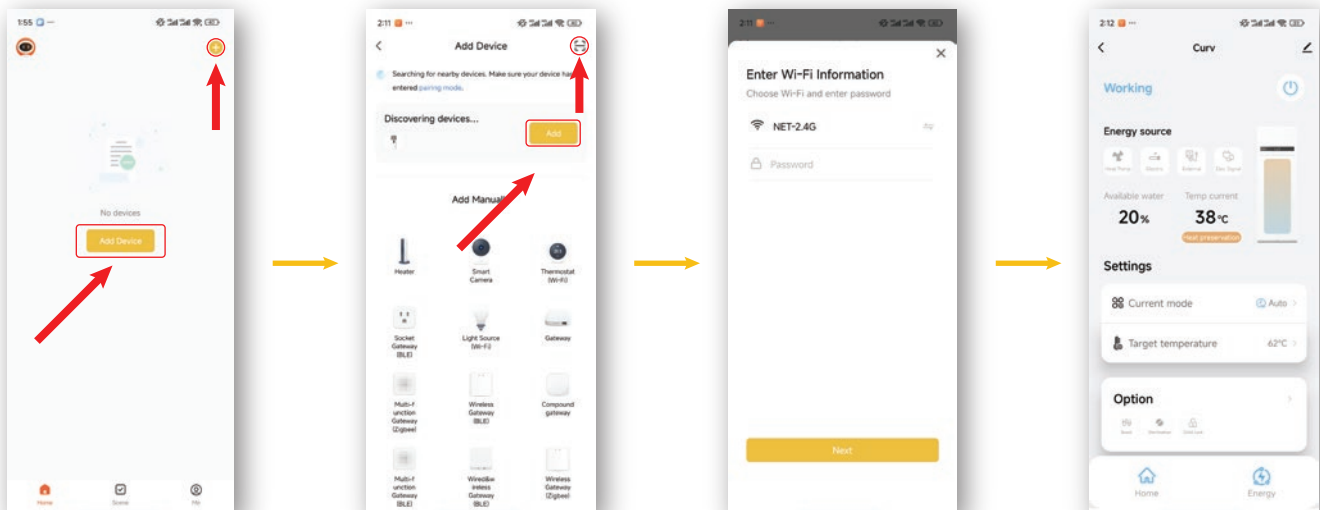

App Status

The Heat Pump is internet-enabled, allowing you to conveniently adjust the temperature and mode using a mobile app. Its one-touch bacteriostasis feature helps ensure your water stays clean and healthy.

Select mode

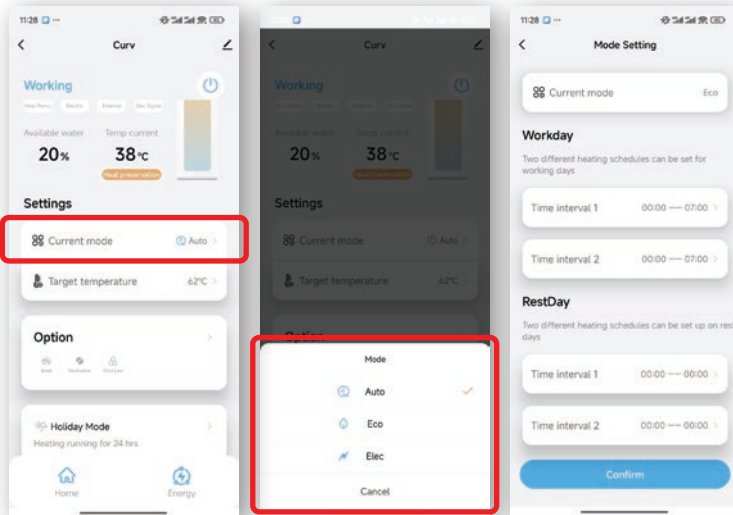

- **Auto Mode:** Once this mode is activated, the device will immediately start the heat pump heating process at any time.
- **ECO Mode:** In this mode, users can customise heating schedules for weekdays and weekends, and optionally enable heating during off-peak electricity hours.
- **Elec Mode:** In this state, the device operates in electric heating mode.

Sterilisation mode

Holiday Mode

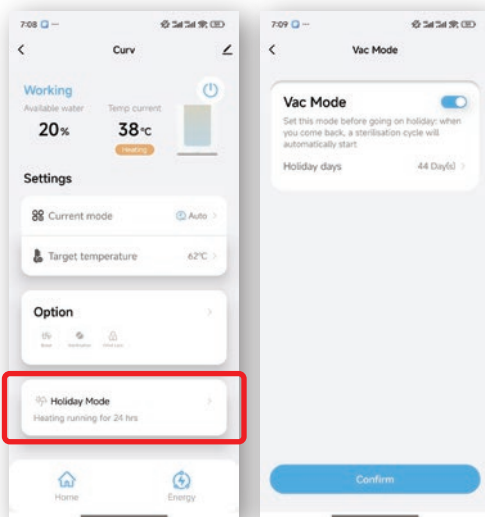

Set the holiday mode before your trip. It will automatically activate the antibacterial function the day before you return, and once sterilisation is complete, the heating system will turn on automatically.

Sterilisation

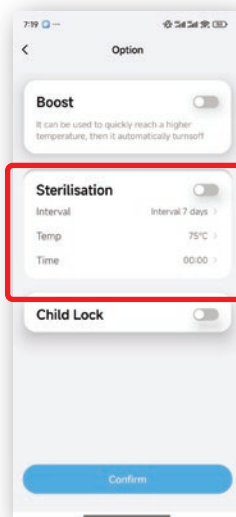

You can set the sterilisation temperature, duration, and frequency, allowing the system to automatically perform cyclic sterilisation for you.

Target Temperature

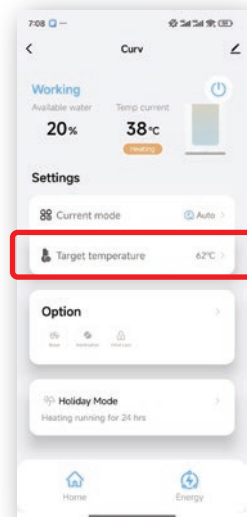

You can adjust the temperature here.

Checking and maintenance



WARNING

- Installation and maintenance of the appliance must be done by a qualified professional.
- Before working on the appliance, Shut down the machine and cut off the power supply.
- Do not touch with wet hands.
- Maintenance operations are important to guarantee optimum performance and extend the life of the equipment.

Checking of the Safety valve

- Operate the safety valve at least once every six months to check if it is running correctly. Otherwise check for blocking and replace the safety valve if necessary.

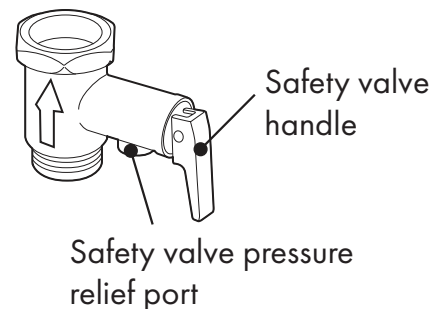

Checking of the hydraulic circuit

- Check the watertightness of the water connections.

Checking of the hydraulic circuit

- Remove the screw in the left with a screwdriver;
- Rotate the top cover counterclockwise until you can take it off.

Checking of the main control board

- Use a screwdriver to remove the screw.

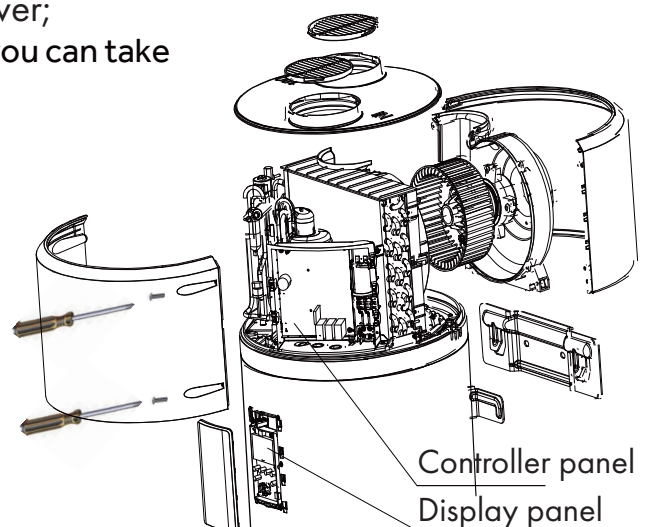

Checking and maintenance

Cleaning of the fan

- Check the cleanliness of the fan one time per year.

Checking of the evaporator



- Because the evaporator fins is very sharp. Risk of injury on your finger.
- Do not damage the fins. Avoid affecting the performance.
- Clean the evaporator at regular intervals using a soft-haired brush.
- If they are bent. Carefully realign the evaporator using a suitable comb.

Checking of the condensates discharge pipe

- Check the pipe cleanliness.
- An obstruction by dust may cause poor condensates flow or even a risk accumulation of water in the heat pump plastic base.

Drain the water tank to empty

- Cut off power supply and shut down water inlet valve, then drain the water tank to empty via the cold water inlet. Please stay away from the cold water inlet if there is hot water inside the water tank to avoid injury.

Faults and protection

Water Quality

Water supply from an unfiltered water source that may be highly conductive or have a high mineral content may void the system warranty.

Therefore, to ensure water quality guidelines are met, the following characteristics should not be exceeded.

Total Dissolved Solids (TDS)

Water Properties	Acceptable Level
Total hardness	200 mg/litre or ppm
Total Dissolved Solids(TDS)	600 mg/litre or ppm
Chloride	200 mg/litre or ppm
Magnesium	10 mg/litre or ppm
Sodium	150 mg/litre or ppm
pH	Min 6.5 to Max 8.5
Electricity conductivity	850 μ S/cm

In areas of poor water quality, it is recommended that a softener, conditioner or similar device be fitted to the water supply.



A breach of this condition may void the warranty in the event of damage caused by water quality exceeding these characteristics.

WARNING

ANODE

The enamel lining cylinder of the water heater is only covered by warranty when the total dissolved solids (TDS) content in water is less than 2500 mg/L and the anode protection equipment is used correctly. If an incorrect colour coded anode is used in the water heater, any resultant faults will not be covered by the warranty. In addition, the use of an incorrect colour coded anode may shorten the life of the water heater cylinder.

The correct colour coded anode is as shown in the following table:

Total Dissolved Solids	Anode colour code
0-40 mg/L	Green
40-150 mg/L	Green or Black
150-400 mg/L	Black
400-600 mg/L	Black or Blue
600-2500 mg/L	Blue
2500 mg/L+	Blue (no cylinder warranty)

Fault type	Action	Digital Indication	Release
Compressor Protection	Operating temperature protection	F2	After fault is solved, switch on power supply for release
	Air exhaust temperature protection	F3	
	Evaporation high temperature protection	F5	
Compressor Over-current Protection	Over-current protection	F6	
Electricity Leakage Alarming	The system will automatically cut off power supply if any line fault occurs	E1	After fault is solved, switch on power supply for release
Over Temperature Alarming	The actual water temperature $\geq 85^{\circ}\text{C}$	E2	
Fault of the Inner Temperature Sensor	If short circuit or circuit break occurs to the sensor	E3	
Fault of the Ambient Temperature Sensor	If short circuit or circuit break occurs to the sensor	E4	
Fault of the Evaporation Temperature Sensor	If short circuit or circuit break occurs to the sensor	E5	
Fault of the Air Exhaust Temperature Sensor	If short circuit or circuit break occurs to the sensor	E6	
Fault of the Air Intake Temperature Sensor	If short circuit or circuit break occurs to the sensor	ED	
Communication Fault	Communication of main control panel and display panel is abnormal	E7	
Pressure Switch Protection	Action of the pressure switch at the exhaust outlet	E8	
Ambient Temperature Protection	Ambient or outdoor temperature $< -7^{\circ}\text{C}$ or $> 45^{\circ}\text{C}$	E9	
Fault of the Solar or Boiler Temperature Sensor	If short circuit or circuit break occurs to the sensor (for HP250M3C)	EE	
Fault of the Off-peak Power Switching Signal	If not received the Off-peak signal when selecting switch signals by power companies	EF	

Fault type	Action	Digital Indication	Release
Transient hardware overcurrent of the press phase current	The MCU detects a low level input at the FO port or a bus current greater than the 19.4A peak threshold set by the MCU internal comparator	P1	Power on or off the device again. The fault is rectified
Press phase current software transient overcurrent	The instantaneous output current is greater than 17A	P2	When the current is less than the set protection value, the system automatically recovers after 20s
The heat sink (IPM)	IPM module temperature $> 100^{\circ}\text{C}$	P3	60 seconds later, the MCU

temperature is too high			detects that the IPM module temperature is lower than 85°C and automatically recovers
Input overflow load	The input current RMS exceeds 18A or the peak output current exceeds 17A	P4	The press automatically recovers after shutdown
undervoltage protection	Bus voltage below 200V lasts for 5ms	P5	If the VDC is greater than or equal to 210V after the compressor is stopped for 20 seconds, the fault is rectified
Over Voltage Protection	PFC voltage or bus voltage VDC greater than 390V for 5ms	P6	After the compressor is stopped for 20 seconds, the fault is rectified if the VDC ≤ 380V
The communication between the main control chip and the driver chip is abnormal	The master control and driver cannot receive data or a data error persists for 2 minutes	P7	After receiving the communication from the other party, it automatically recovers and the fault is eliminated
The current detection on the frequency conversion side is abnormal	Before the press is in operation, there is a 10-20% deviation between the AD value of the incoming voltage detected by the sampling circuit and the AD value of 1.65V	P8	The circuit is repaired and then powered on again
Press out of step	The actual running speed of the compressor is less than 50% or more than 120% of the target speed of the drive for more than 5S	PB	Detect normal fault elimination
Instantaneous Software Overflow on the rectifier Side	The instantaneous value of the input current is greater than 30A for 3 times, and each PWM cycle is detected once	PD	After the press is stopped for 20 seconds, the current is less than 30A and automatically recovers. Power off and restart. The fault is rectified
Transient hardware overcurrent on the rectifier side	The instantaneous input current is greater than 31A for four times	PF	The press automatically recovers when the current is less than 31A after 20 seconds of shutdown. Power off and restart. The fault is rectified
Boiler/solar sensor failure	On the premise that the boiler/solar switch signal is turned on, the sensor is detected to be short and open for 3s	Lb	Detect normal fault elimination

Faults and protection

NO.	Fault Category	Action conditions	Digital indicaiton
1	Communication fault	Communication failure between Wi-Fi module and control board	F0
2	Compressor protection (ring temperature protection)	If the ambient temperature does not meet the operating conditions after the compressor is started for 5 minutes, shut down the compressor. Start auxiliary heating and heat to the set temperature	F2
3	Compressor protection (high exhaust temperature)	Exhaust temperature $\geq 115^{\circ}\text{C}$ for 30s	F3
4	Leakage alarm	When the leakage current is $\geq 15\text{mA}$, cut off the power supply	E1
5	Overtemperature alarm	Fault alarm above 88°C	E2
6	The temperature sensor in the tank is faulty	If short circuit or circuit break occurs to the sensor	E3
7	Ambient temperature sensor fault	If short circuit or circuit break occurs to the sensor	E4
8	Evaporation temperature sensor fault	If short circuit or circuit break occurs to the sensor	E5
9	Suction temperature sensor fault	If short circuit or circuit break occurs to the sensor	Ed
10	Exhaust temperature sensor fault	If short circuit or circuit break occurs to the sensor	E6
11	Communication failure	The communication between the main control board and the display board is abnormal, and the main control board and the remote controller	E7
12	Pressure switch protection	Pressure switch action	E8
13	Ambient temperature protection	When the ambient temperature is detected to be less than -7°C or more than 45°C , the electric heating will start automatically and heat to the set temperature this time.	E9
14	Low voltage switch failure	When judging the low power by the switch signal of the power company, if the low power signal is not received within 24 hours, the switch circuit is considered to be fault.	EF
15	DC fan fault	After receivig the fan start signal, the fan feedback signal is not detected for 30 seconds, and the fan fault is reported.	L7

Fault code identification method

“E1” error code and identification process

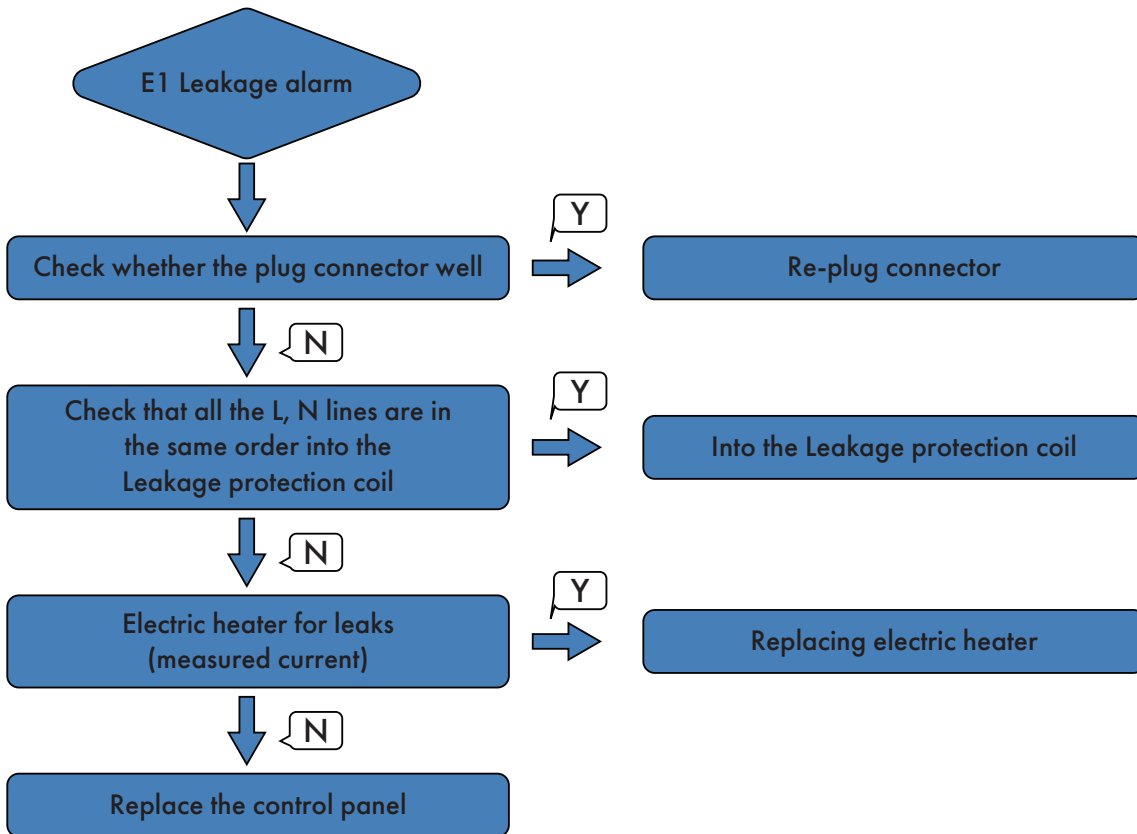

“E2” error code and identification process

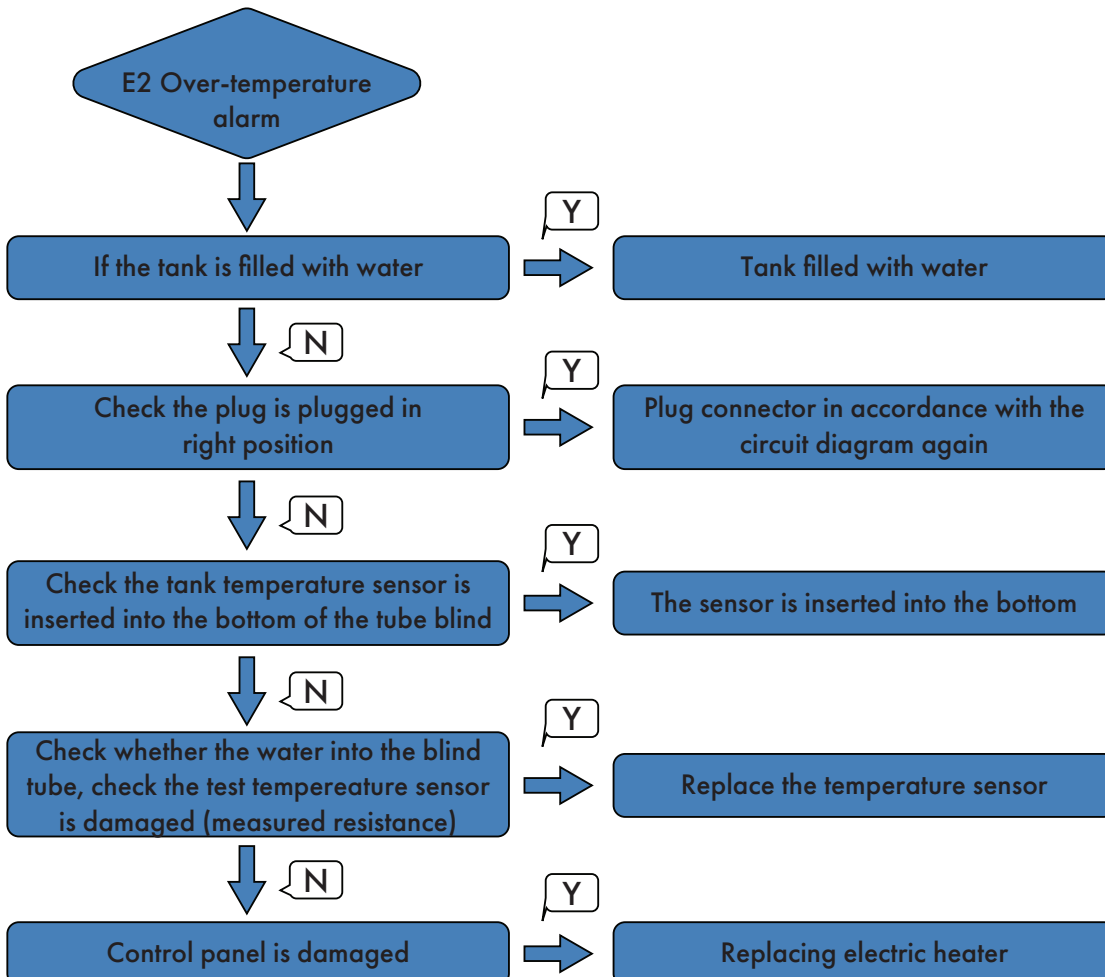

“E3, E4, E5, E6,Ed” error code and identification process

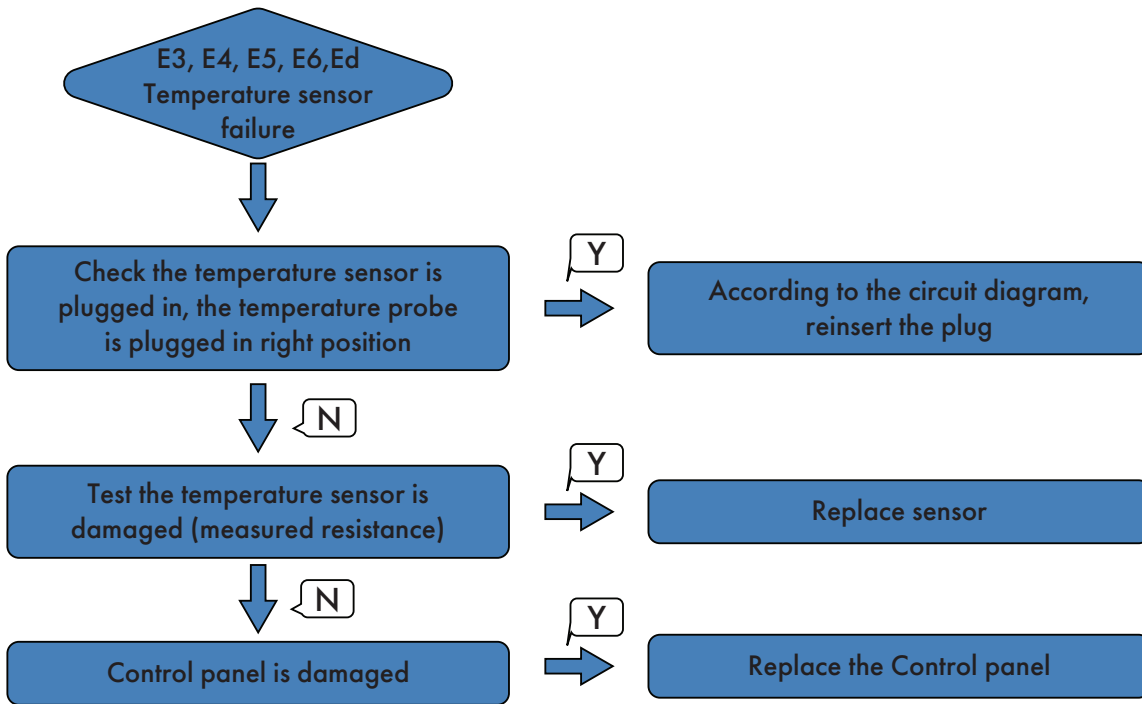

“E7” error code and identification process

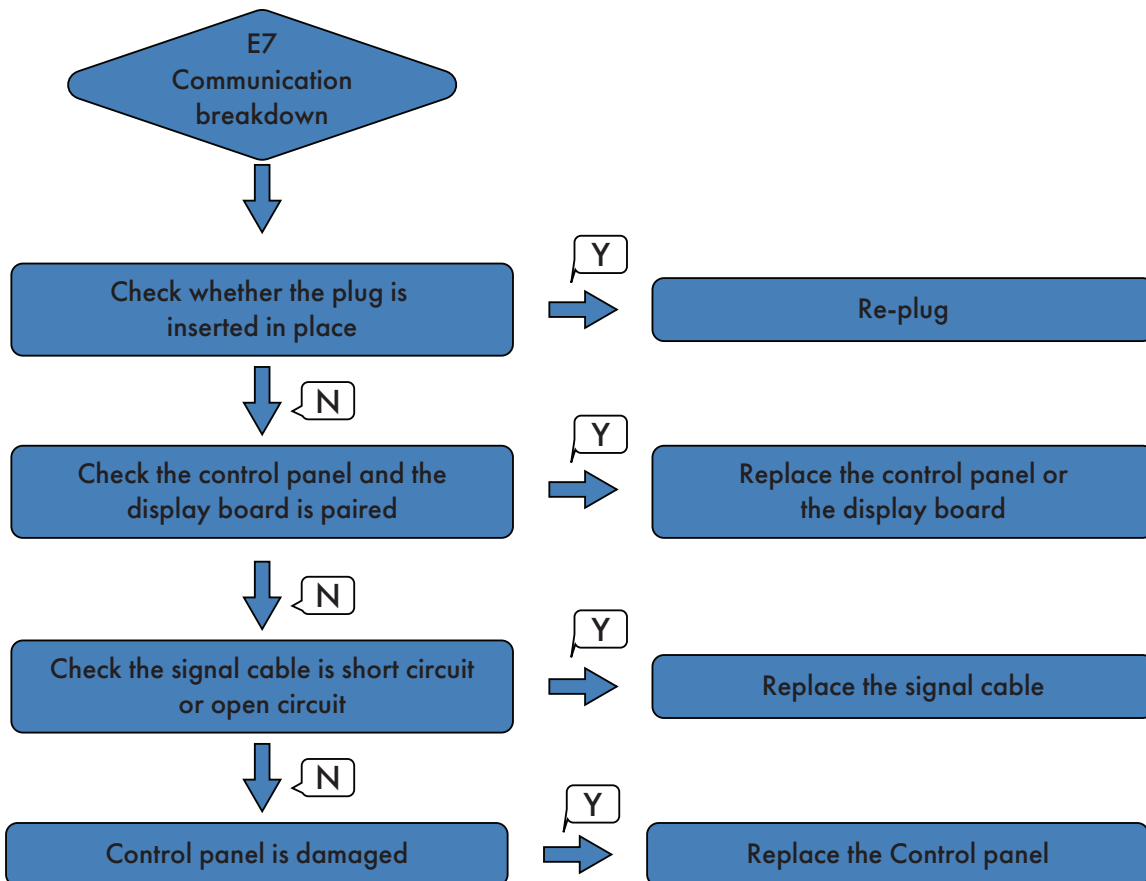

"E8" error code and identification process

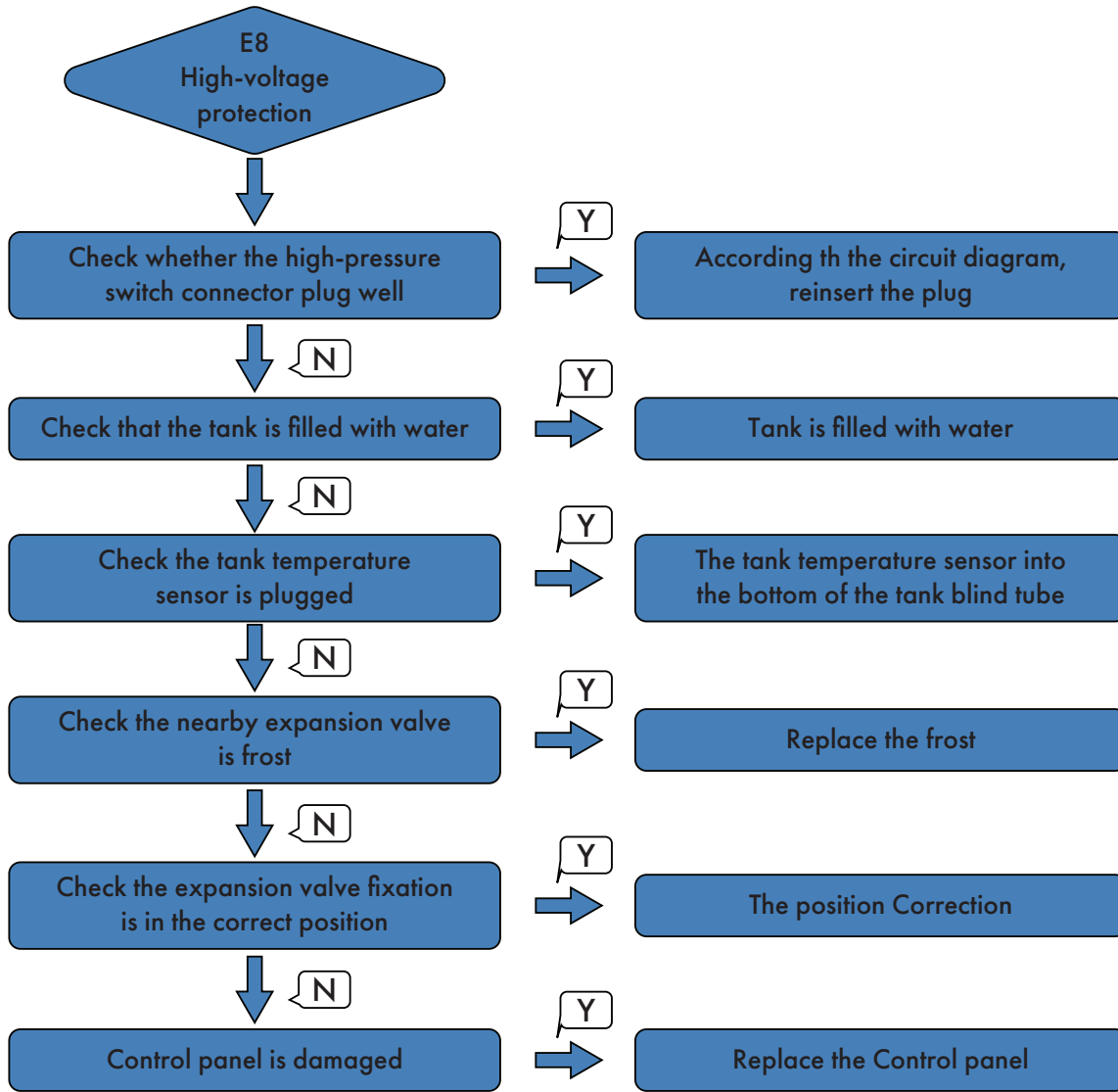

"E9, F2" error code and identification process

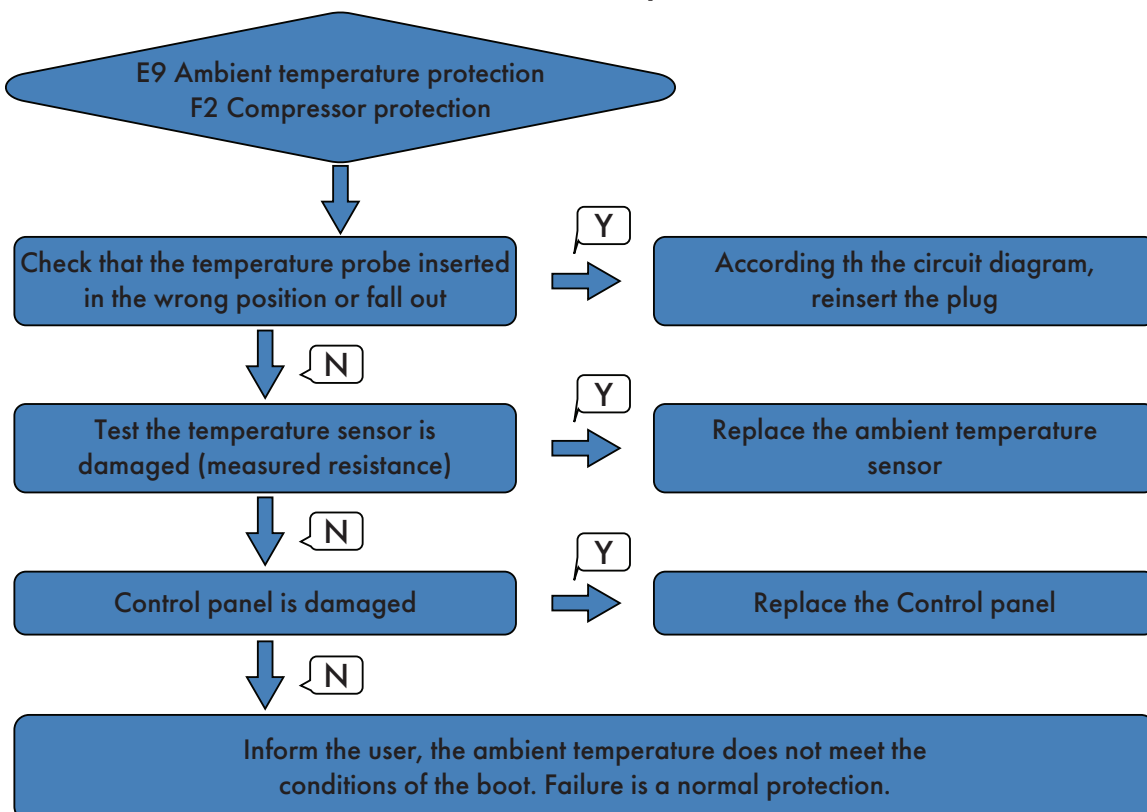

"F3" error code and identification process

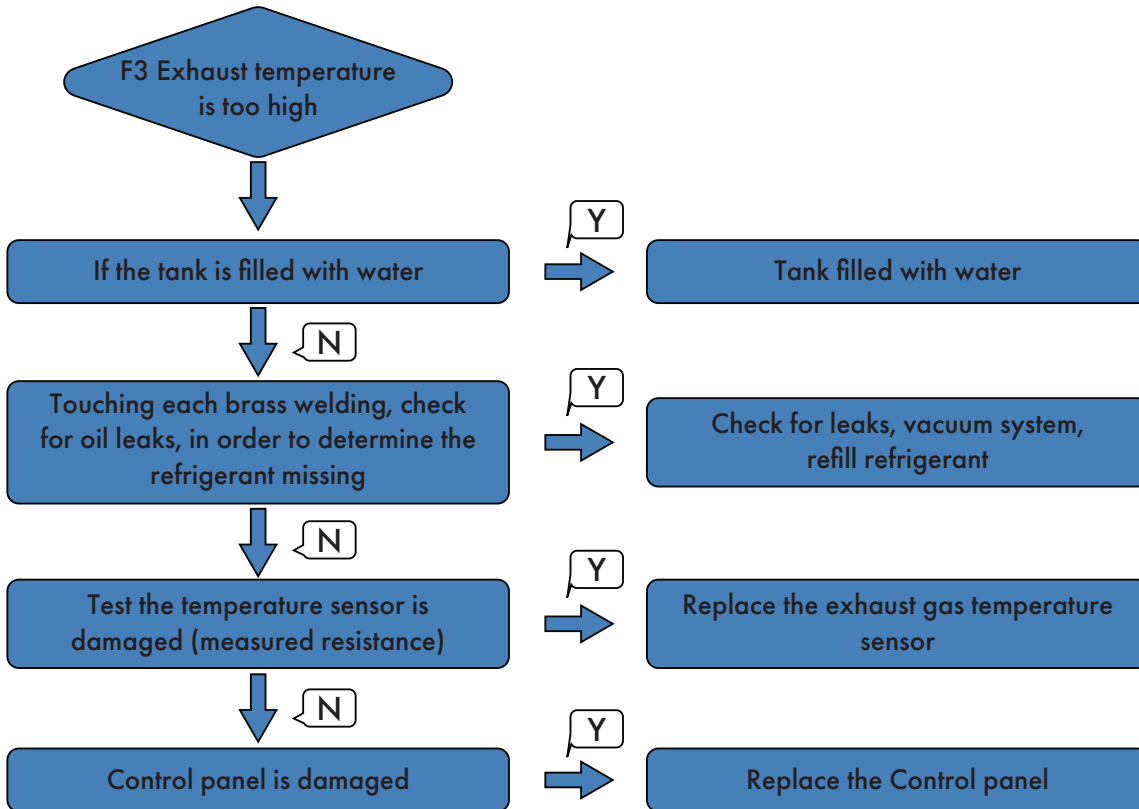

"F5" error code and identification process

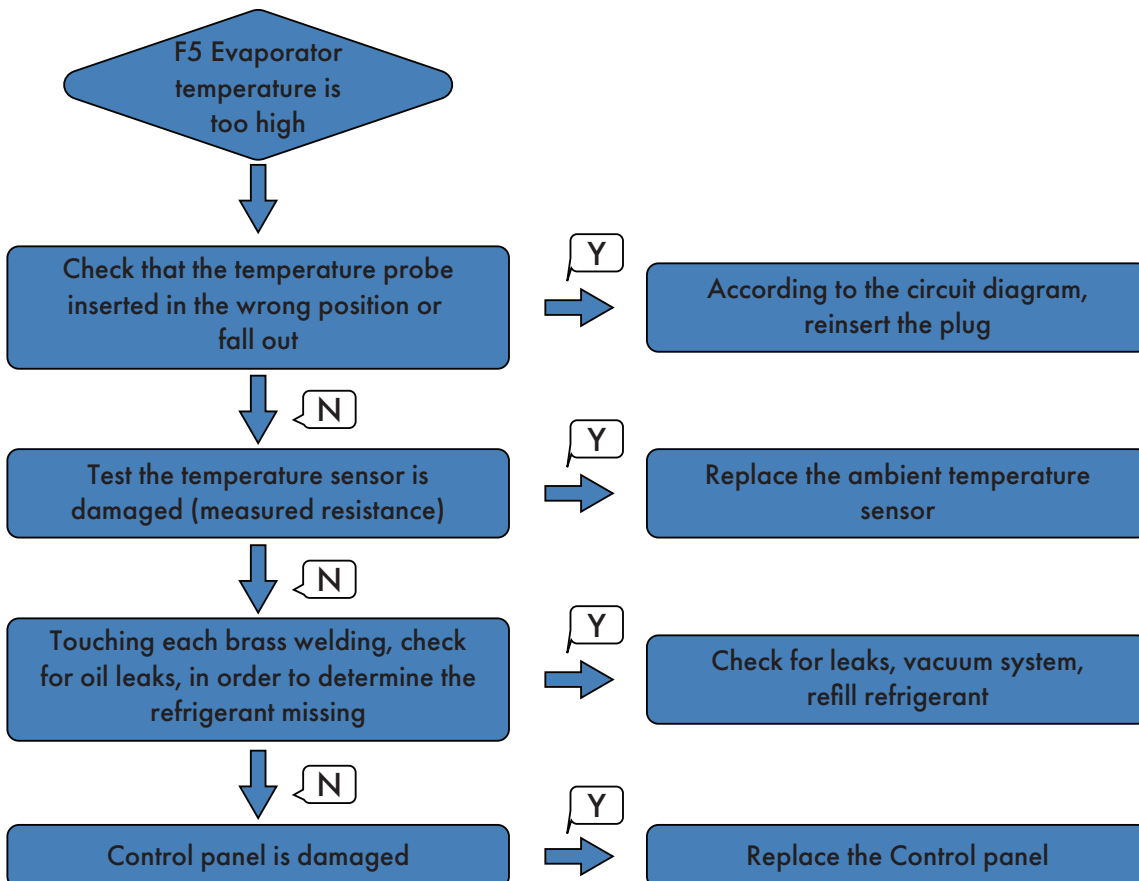

"F6" error code and identification process

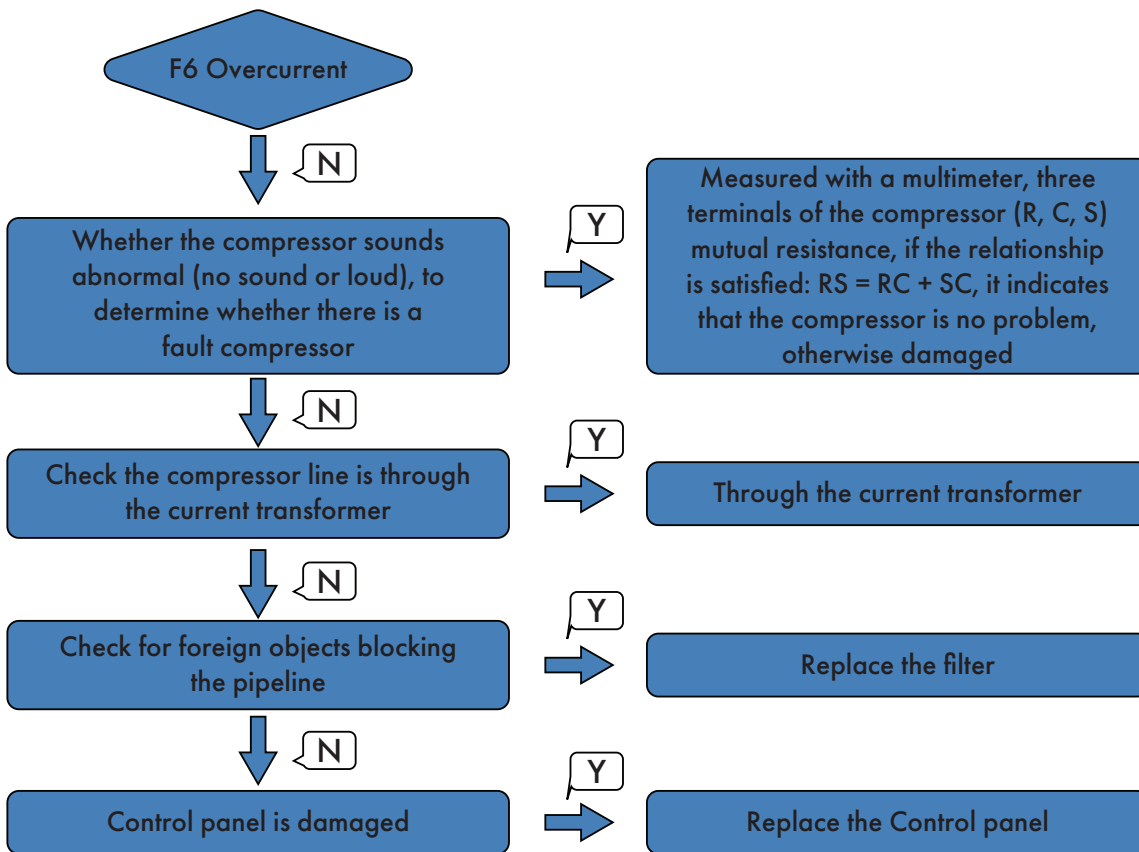

Temperature sensor resistance measurement method

Temperature sensor resistance measurement method (method of measuring the resistance value of the compressor of the same, but is switched to the small resistance of the interface unit).

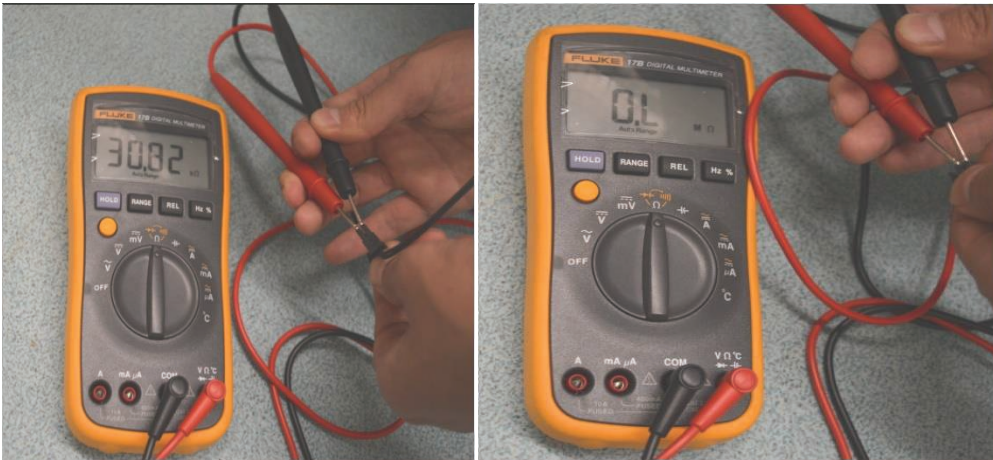

Multimeter set to Ohms, according to the picture of the method of measuring the resistance of the temperature sensor. According to the resistance table, the lower the temperature the smaller the resistance.

Check the signal cable is short-circuited

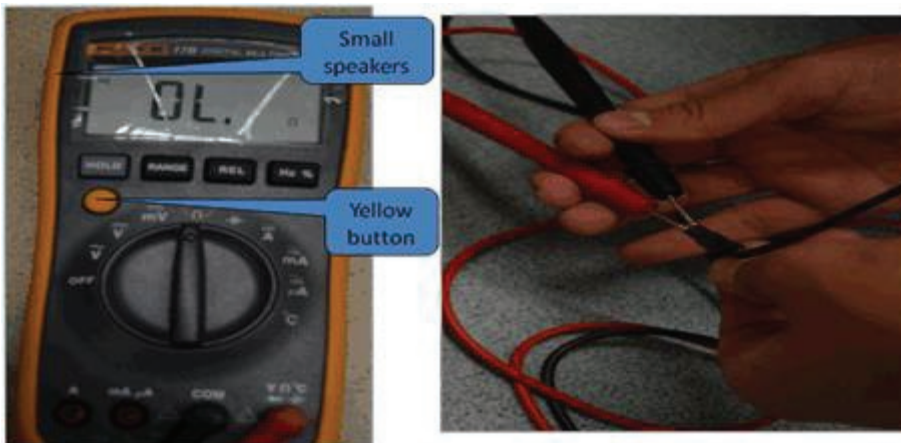

Press the yellow button to switch to the picture, when a short circuit, there is a beep, the resistance is zero.

Check that the power cord L, N lines are in the same order into the leakage protection coil

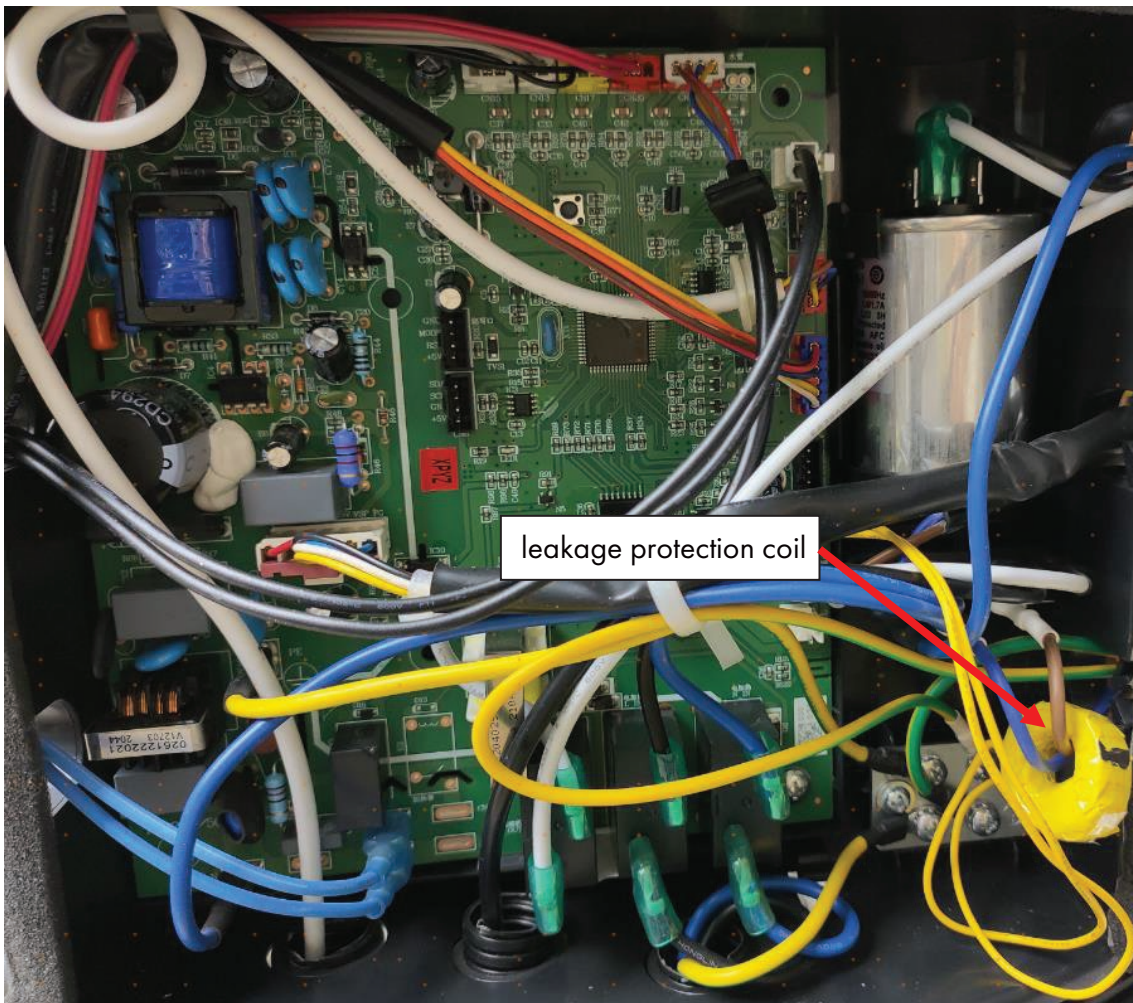

The method of dismantling products

Make sure the power cord is disconnected.

1. Remove the Top Cover

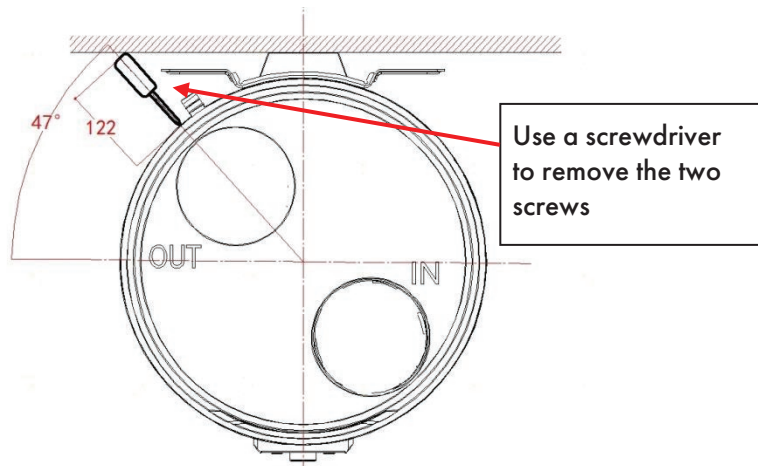

2. Remove the Bottom Cover

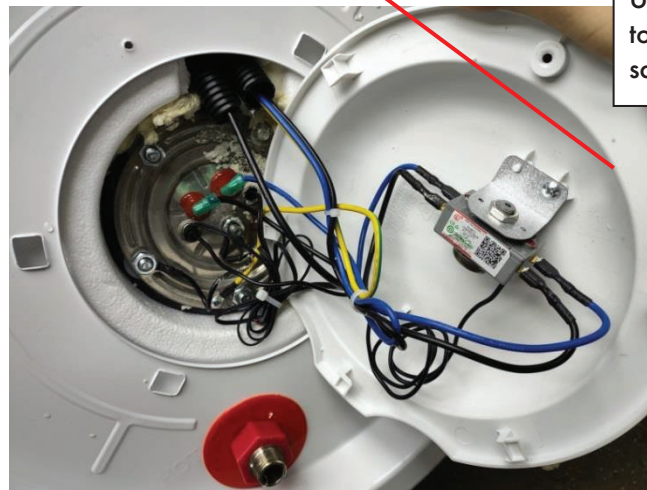

Use a screwdriver to remove the two screws

3. Remove the Air channel and fan

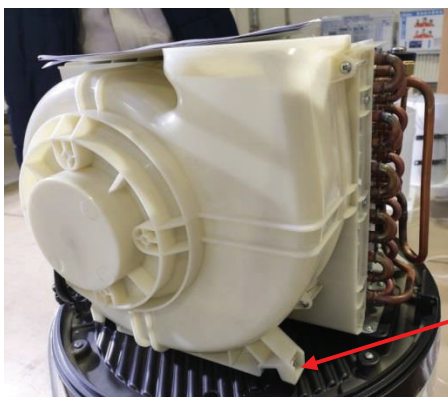

Use a screwdriver to remove the two screws

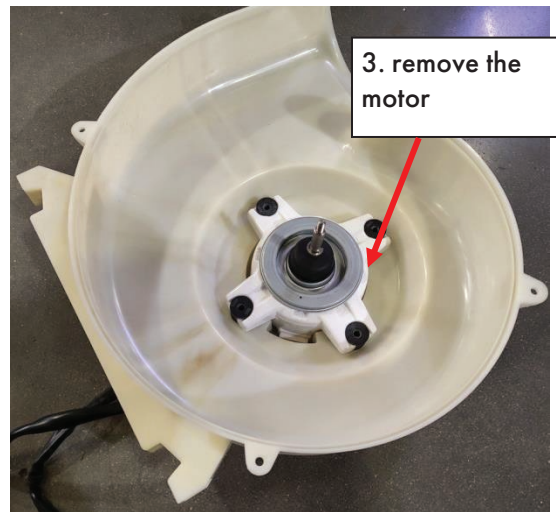
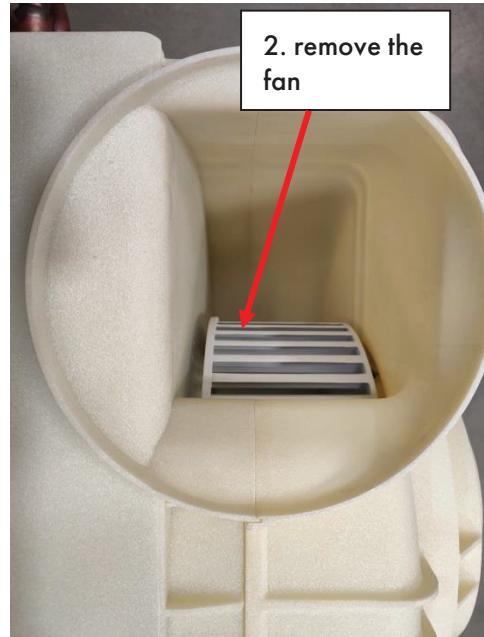
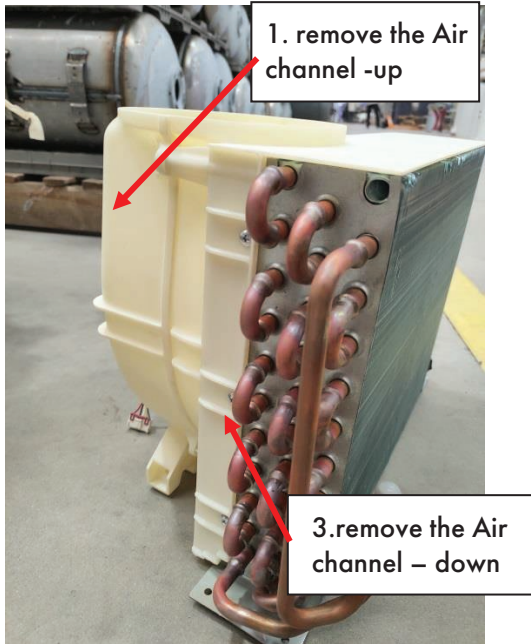

4. Remove the Magnesium rod

Off the power and close the inlet valve, open any outlet valve, exhaust pressure, when no water flows out of time, turn off all the valves.

- ① Remove the magnesium rod cover;
- ② After remove the magnesium rod, according to the consumption of magnesium rod, determine whether you need to replace.

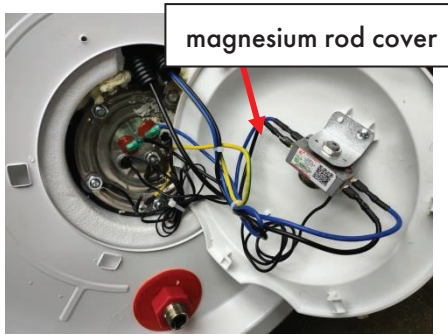

magnesium rod cover



magnesium rod

5. Open the control box

Exhaust, defrosting, and ambient temperature sensors 0040402464

Suction temperature sensor 0040402464G

Controller panel

EVU 0040400419R

Compressor wiring harness 0040403400

Display board wiring 004040092B

Compressor capacitor 0040402549

HC/HP harness 0040400419Q

Heater harness 0040402521A

Heater harness 0040402520A

Ground wire 0040401356B

L, N line 0040402789

Compressor capacitor line 0040403178

6. Remove the Display board box



Use a screwdriver to remove the screw



0040400092CB Display board wiring

0040400419Q WIFI line

0041800214PB
WIFI module



MAC Code

The method of Charge of the refrigerant gas



1. Check the heat pump system refrigerant leakage method:

In the heating process, heat pump input power has remained unchanged;

During heating, the temperature of the water in the tank is constant (ensure that the electric heater is not activated).

2. Leakage check:

If you have confirmed that the system has been leaked, please check it as follows.

Unscrew the maintenance valve nut, access to nitrogen, to maintain pressure 1 MPa.

Apply soap bubbles evenly over the solder joints of the copper tube. Observe the changes in the status of soap bubbles to determine the location of leakage.

After the professionals repair the welding leakage point, check the leakage again with the above method until it is confirmed that the system has no leakage point.









3. Making the vacuum & Gas Charging:

Bleeding from the circuit should take place with a vacuum pump and pressure gauge assembly suitable for R290.

Make sure the vacuum pump is full of oil up to the level indicated by the oil gauge.

1. Connect the manometer on the low pressure service valve of heat pump, and connect the refrigerant cylinder to the other side the manometer.
2. Connect the vacuum pump to the center tap of the manometer.
3. After opened the valves of the vacuum pump, start it and let it run. Create a vacuum for about 20 / 25 minutes;
4. Close the valves of the pump and shut off. Verify that the gauge needle does not move for about 5 minutes.
5. Disconnect the vacuum pump;
6. Open the container of the refrigerant then open the main valve cap pressure gauge and adjust the needle valve until you hear the coolant leak, and release the pin and close the valve of the pipe;
7. Keep under control the weight of the refrigerant tank through the electronic scale;
8. Open the ball valve and to flow the refrigerant gradually;
9. After reaching the mass of gas to be loaded close the tap(0.12kg);
10. Remove the manometer and charging hose from the valve;
11. turn the product in heat pump mode with the detector and check for leaks of refrigerant;
12. Remove the container from the manifold and replace all the equipment.

Repairs common tools

Tools Name	Quantity	Illustration
Spanner	1pc	
Torque Spanner	1pc	
Hexagon Spanner	1pc	
Flathead screwdriver	1pc	
Phillips screwdriver	1pc	
Needle-nose pliers	1pc	
Measuring tape	1pc	
Pressure gauge	1pc	
Vacuum pump	1pc	
Electronic scale	1pc	
Bending device	1pc	

Attachment: Sensor Temperature and Resistance Comparison Table

Ambient-evaporator-suction T sensor:

R25=10K±3%; B25/50=3700K±3%

Temp (°C)	resistance (KΩ)		
	Rmax	R (t) Normal	Rmin
-40	249.020	231.216	213.412
-39	235.632	218.928	202.224
-38	223.031	207.355	191.679
-37	211.149	196.436	181.723
-36	199.933	186.123	172.313
-35	189.335	176.372	163.409
-34	179.314	167.146	154.978
-33	169.836	158.414	146.992
-32	160.867	150.147	139.427
-31	152.381	142.319	132.257
-30	144.350	134.907	125.464
-29	136.519	127.675	118.831
-28	129.381	121.081	112.781
-27	122.638	114.849	107.060
-26	116.268	108.958	101.648
-25	110.249	103.388	96.527
-24	104.563	98.123	91.683
-23	99.190	93.144	87.098
-22	94.111	88.435	82.759
-21	89.311	83.982	78.653
-20	84.518	79.529	74.540
-19	80.484	75.785	71.086
-18	76.428	72.015	67.602
-17	72.591	68.447	64.303
-16	68.963	65.071	61.179
-15	65.530	61.874	58.218
-14	62.283	58.848	55.413
-13	59.210	55.983	52.756
-12	56.300	53.269	50.238
-11	53.547	50.699	47.851
-10	50.940	48.264	45.588
-9	48.472	45.957	43.442
-8	46.134	43.770	41.406
-7	43.918	41.697	39.476
-6	41.819	39.731	37.643
-5	39.830	37.868	35.906
-4	37.944	36.100	34.256
-3	36.157	34.423	32.689
-2	34.462	32.832	31.202
-1	32.854	31.322	29.790
0	31.362	29.920	28.478
1	29.881	28.527	27.173
2	28.507	27.234	25.961
3	27.202	26.006	24.810

4	25.965	24.840	23.715
5	24.788	23.731	22.674
6	23.672	22.678	21.684
7	22.610	21.676	20.742
8	21.601	20.723	19.845
9	20.642	19.817	18.992
10	19.730	18.955	18.180
11	18.864	18.135	17.406
12	18.039	17.354	16.669
13	17.254	16.611	15.968
14	16.507	15.903	15.299
15	15.797	15.229	14.661
16	15.120	14.587	14.054
17	14.476	13.975	13.474
18	13.862	13.392	12.922
19	13.277	12.836	12.395
20	12.720	12.306	11.892
21	12.189	11.801	11.413
22	11.683	11.319	10.955
23	11.200	10.858	10.516
24	10.739	10.419	10.099
25	10.300	10.000	9.700
26	9.894	9.600	9.306
27	9.505	9.217	8.929
28	9.134	8.852	8.570
29	8.779	8.503	8.227
30	8.441	8.170	7.899
31	8.116	7.851	7.586
32	7.805	7.546	7.287
33	7.509	7.255	7.001
34	7.225	6.976	6.727
35	6.953	6.710	6.467
36	6.692	6.454	6.216
37	6.443	6.210	5.977
38	6.204	5.976	5.748
39	5.976	5.753	5.530
40	5.756	5.538	5.320
41	5.546	5.333	5.120
42	5.345	5.136	4.927
43	5.151	4.947	4.743
44	4.967	4.767	4.567
45	4.788	4.593	4.398
46	4.618	4.427	4.236
47	4.455	4.268	4.081
48	4.298	4.115	3.932
49	4.147	3.968	3.789
50	4.004	3.829	3.654

51	3.863	3.692	3.521
52	3.729	3.562	3.395
53	3.601	3.438	3.275
54	3.478	3.318	3.158
55	3.359	3.203	3.047
56	3.246	3.093	2.940
57	3.136	2.987	2.838
58	3.031	2.885	2.739
59	2.930	2.787	2.644
60	2.833	2.693	2.553
61	2.739	2.602	2.465
62	2.649	2.515	2.381
63	2.562	2.431	2.300
64	2.478	2.350	2.222
65	2.398	2.273	2.148
66	2.320	2.198	2.076
67	2.246	2.126	2.006
68	2.174	2.057	1.940
69	2.104	1.990	1.876
70	2.038	1.926	1.814
71	1.974	1.864	1.754
72	1.912	1.805	1.698
73	1.853	1.748	1.643
74	1.795	1.692	1.589
75	1.739	1.639	1.539
76	1.686	1.588	1.490
77	1.634	1.538	1.442
78	1.585	1.491	1.397
79	1.537	1.445	1.353
80	1.490	1.400	1.310
81	1.445	1.357	1.269
82	1.402	1.316	1.230
83	1.361	1.276	1.191
84	1.321	1.238	1.155
85	1.281	1.200	1.119
86	1.244	1.165	1.086
87	1.209	1.131	1.053
88	1.173	1.097	1.021
89	1.140	1.065	0.990
90	1.107	1.034	0.961
91	1.076	1.004	0.932
92	1.045	0.975	0.905
93	1.016	0.947	0.878
94	0.987	0.920	0.853
95	0.960	0.894	0.828
96	0.934	0.869	0.804
97	0.907	0.844	0.781

98	0.883	0.821	0.759
99	0.859	0.798	0.737
100	0.836	0.776	0.716
101	0.814	0.755	0.696
102	0.791	0.734	0.677
103	0.771	0.715	0.659
104	0.750	0.695	0.640
105	0.731	0.677	0.623

Exhaust T sensor :

R80=50KΩ±3%, B25/80=4450±3%

Temp (°C)	resistance (KΩ)		
	Rmax	R (t) Normal	Rmin
-30	12318.968	11021.678	9724.388
-29	11551.311	10343.407	9135.504
-28	10835.229	9710.234	8585.239
-27	10167.003	9118.935	8070.867
-26	9543.200	8566.532	7589.865
-25	8960.652	8050.276	7139.901
-24	8416.430	7567.624	6718.818
-23	7907.828	7116.224	6324.620
-22	7432.345	6693.901	5955.457
-21	6987.666	6298.642	5609.618
-20	6571.650	5928.583	5285.516
-19	6187.164	5586.374	4985.585
-18	5826.712	5265.313	4703.915
-17	5488.692	4964.004	4439.315
-16	5171.616	4681.148	4190.680
-15	4874.100	4415.539	3956.978
-14	4594.858	4166.054	3737.249
-13	4332.694	3931.647	3530.600
-12	4086.494	3711.346	3336.198
-11	3855.222	3504.244	3153.266
-10	3637.915	3309.498	2981.082
-9	3433.673	3126.321	2818.969
-8	3241.661	2953.980	2666.299
-7	3061.098	2791.790	2522.482
-6	2891.257	2639.114	2386.971
-5	2731.460	2495.357	2259.253
-4	2581.076	2359.962	2138.848
-3	2439.514	2232.412	2025.310
-2	2306.222	2112.221	1918.220
-1	2180.688	1998.938	1817.187
0	2094.972	1921.993	1749.014
1	1975.099	1813.265	1651.431
2	1863.127	1711.646	1560.165
3	1758.449	1616.593	1474.737
4	1660.513	1527.611	1394.709
5	1568.817	1444.250	1319.683
6	1482.897	1366.096	1249.295
7	1402.336	1292.773	1183.210
8	1326.746	1223.935	1121.124
9	1255.774	1159.265	1062.756

54	145.099	138.255	131.411
55	139.078	132.613	126.148
56	133.336	127.229	121.122
57	127.858	122.089	116.320
58	122.630	117.181	111.732
59	117.641	112.494	107.347
60	112.879	108.018	103.157
61	108.332	103.741	99.150
62	103.989	99.654	95.319
63	99.841	95.748	91.655
64	95.879	92.014	88.149
65	92.091	88.443	84.795
66	88.472	85.028	81.584
67	85.011	81.761	78.511
68	81.703	78.636	75.569
69	78.538	75.645	72.752
70	75.510	72.781	70.052
71	72.614	70.040	67.466
72	69.842	67.415	64.988
73	67.189	64.901	62.613
74	64.649	62.493	60.337
75	62.216	60.185	58.154
76	59.886	57.973	56.060
77	57.653	55.852	54.051
78	55.515	53.820	52.125
79	53.465	51.870	50.275
80	51.500	50.000	48.500
81	49.684	48.206	46.728
82	47.940	46.484	45.028
83	46.267	44.832	43.397
84	44.659	43.246	41.833
85	43.114	41.723	40.332
86	41.629	40.260	38.891
87	40.203	38.856	37.509
88	38.831	37.506	36.181
89	37.513	36.209	34.905
90	36.244	34.962	33.680
91	35.025	33.764	32.503
92	33.851	32.612	31.373
93	32.722	31.504	30.286
94	31.636	30.439	29.242
95	30.590	29.413	28.236
96	29.583	28.427	27.271
97	28.614	27.478	26.342

98	27.680	26.564	25.448
99	26.781	25.685	24.589
100	25.914	24.838	23.762
101	25.080	24.023	22.966
102	24.275	23.237	22.199
103	23.500	22.481	21.462
104	22.753	21.752	20.751
105	22.031	21.049	20.067
106	21.336	20.372	19.408
107	20.667	19.720	18.773
108	20.020	19.091	18.162
109	19.397	18.485	17.573
110	18.795	17.900	17.005
111	18.215	17.337	16.459
112	17.655	16.793	15.931
113	17.114	16.268	15.422
114	16.593	15.763	14.933
115	16.090	15.275	14.460
116	15.603	14.804	14.005
117	15.133	14.349	13.565
118	14.681	13.911	13.141
119	14.243	13.488	12.733
120	13.821	13.080	12.339
121	13.412	12.685	11.958
122	13.019	12.305	11.591
123	12.638	11.938	11.238
124	12.271	11.584	10.897
125	11.917	11.242	10.567
126	11.573	10.911	10.249
127	11.243	10.593	9.943
128	10.923	10.285	9.647
129	10.614	9.988	9.362
130	10.315	9.701	9.087
131	10.028	9.425	8.822
132	9.750	9.158	8.566
133	9.481	8.900	8.319
134	9.222	8.651	8.080
135	8.972	8.411	7.850
136	8.731	8.180	7.629
137	8.498	7.957	7.416
138	8.273	7.741	7.209
139	8.055	7.533	7.011
140	7.846	7.333	6.820
141	7.628	7.125	6.621

142	7.417	6.923	6.429
143	7.213	6.728	6.243
144	7.014	6.538	6.062
145	6.822	6.355	5.888
146	6.636	6.178	5.719
147	6.455	6.006	5.556
148	6.280	5.839	5.398
149	6.111	5.678	5.244
150	5.946	5.521	5.096

Tank temperature sensor:

$B0/100=3970K \pm 2\%$, $R_{25^{\circ}C}=49.12K \Omega \pm 2\%$

Temp (°C)	resistance (KΩ)			Temp (°C)	resistance (KΩ)		
	Rmax	R (t) Normal	Rmin		Rmax	R (t) Normal	Rmin
-30	895.026	861.099	827.172	17	71.407	70.434	69.462
-29	841.216	809.827	778.438	18	68.167	67.27	66.373
-28	790.949	761.905	732.861	19	65.091	64.265	63.438
-27	743.979	717.102	690.225	20	62.17	61.41	60.65
-26	700.073	675.199	650.324	21	59.396	58.697	57.999
-25	659.017	635.994	612.971	22	56.76	56.119	55.477
-24	620.611	599.3	577.989	23	54.255	53.668	53.08
-23	584.671	564.943	545.215	24	51.875	51.337	50.799
-22	551.024	532.761	514.498	25	49.611	49.12	48.629
-21	519.514	502.607	485.699	26	47.5	47.011	46.521
-20	489.992	474.339	458.686	27	45.491	45.004	44.517
-19	462.36	447.83	433.3	28	43.577	43.093	42.609
-18	436.45	422.962	409.473	29	41.754	41.274	40.793
-17	412.145	399.623	387.1	30	40.018	39.542	39.065
-16	389.336	377.71	366.084	31	38.364	37.891	37.419
-15	367.922	357.128	346.334	32	36.786	36.318	35.85
-14	347.812	337.789	327.767	33	35.282	34.819	34.356
-13	328.917	319.611	310.306	34	33.849	33.391	32.933
-12	311.156	302.516	293.876	35	32.48	32.028	31.576
-11	294.458	286.436	278.415	36	31.175	30.728	30.282
-10	278.751	271.304	263.856	37	29.929	29.489	29.048
-9	263.97	257.057	250.143	38	28.741	28.306	27.871
-8	250.058	243.64	237.223	39	27.605	27.176	26.748
-7	236.957	231.001	225.044	40	26.521	26.098	25.676
-6	224.616	219.088	213.56	41	25.484	25.068	24.652
-5	212.985	207.856	202.727	42	24.494	24.085	23.675
-4	202.022	197.264	192.506	43	23.548	23.145	22.742
-3	191.683	187.27	182.857	44	22.644	22.247	21.851
-2	181.93	177.838	173.746	45	21.779	21.389	20.999
-1	172.727	168.934	165.14	46	20.951	20.568	20.184
0	164.04	160.524	157.009	47	20.16	19.783	19.405
1	155.848	152.579	149.311	48	19.403	19.032	18.661
2	148.11	145.071	142.032	49	18.677	18.313	17.949
3	140.799	137.974	135.15	50	17.983	17.625	17.267
4	133.887	131.262	128.638	51	17.318	16.967	16.617
5	127.351	124.913	122.475	52	16.68	16.336	15.993
6	121.17	118.906	116.641	53	16.068	15.732	15.396
7	115.323	113.221	111.118	54	15.484	15.155	14.825
8	109.788	107.837	105.886	55	14.922	14.599	14.277
9	104.548	102.738	100.929	56	14.385	14.069	13.753
10	99.587	97.909	96.231	57	13.868	13.559	13.25
11	94.887	93.332	91.777	58	13.374	13.071	12.768
12	90.435	88.995	87.554	59	12.899	12.602	12.306
13	86.215	84.881	83.548	60	12.443	12.153	11.863
14	82.214	80.98	79.746	61	12.006	11.722	11.438
15	78.42	77.28	76.139	62	11.586	11.308	11.03
16	74.821	73.767	72.714	63	11.184	10.912	10.639

Temp	resistance (K Ω)			Temp	resistance (K Ω)		
($^{\circ}$ C)	Rmax	R (t) Normal	Rmin	($^{\circ}$ C)	Rmax	R (t) Normal	Rmin
64	10.797	10.53	10.264	107	2.77	2.664	2.559
65	10.425	10.164	9.903	108	2.694	2.591	2.487
66	10.067	9.812	9.557	109	2.62	2.519	2.417
67	9.724	9.474	9.224	110	2.549	2.45	2.351
68	9.394	9.149	8.905	111	2.481	2.383	2.286
69	9.076	8.837	8.597	113	2.349	2.256	2.162
70	8.771	8.537	8.303	114	2.287	2.196	2.104
71	8.478	8.248	8.019	115	2.228	2.138	2.048
72	8.196	7.971	7.747	116	2.169	2.081	1.993
73	7.924	7.704	7.484	117	2.113	2.027	1.94
74	7.663	7.448	7.233	118	2.058	1.974	1.889
75	7.411	7.201	6.991	119	2.006	1.923	1.839
76	7.169	6.963	6.757	120	1.955	1.873	1.792
77	6.936	6.734	6.533	121	1.905	1.825	1.745
78	6.712	6.514	6.317	122	1.857	1.779	1.701
79	6.495	6.302	6.109	123	1.812	1.735	1.658
80	6.287	6.098	5.909	124	1.766	1.691	1.615
81	6.086	5.901	5.716	125	1.723	1.649	1.575
82	5.893	5.712	5.53	126	1.681	1.608	1.536
83	5.706	5.529	5.352	127	1.64	1.569	1.498
84	5.527	5.353	5.179	128	1.599	1.53	1.46
85	5.354	5.184	5.014	129	1.561	1.492	1.424
86	5.187	5.021	4.855	130	1.523	1.456	1.389
87	5.027	4.864	4.701	131	1.487	1.421	1.355
88	4.871	4.712	4.553	132	1.451	1.386	1.321
89	4.722	4.566	4.411	133	1.416	1.353	1.289
90	4.577	4.425	4.273	134	1.383	1.32	1.258
91	4.438	4.289	4.14	135	1.35	1.289	1.228
92	4.303	4.158	4.012	136	1.318	1.257	1.197
93	4.174	4.032	3.889	137	1.286	1.227	1.168
94	4.049	3.91	3.77	138	1.255	1.198	1.14
95	3.929	3.792	3.656	139	1.225	1.168	1.111
96	3.813	3.679	3.545	140	1.195	1.14	1.084
97	3.7	3.569	3.438	141	1.166	1.111	1.056
98	3.592	3.464	3.336	142	1.137	1.084	1.03
99	3.487	3.362	3.236	143	1.109	1.056	1.004
100	3.386	3.264	3.141	144	1.081	1.03	0.978
101	3.288	3.168	3.048	145	1.053	1.003	0.953
102	3.194	3.077	2.959	146	1.026	0.977	0.927
103	3.103	2.988	2.873	147	0.999	0.951	0.903
104	3.016	2.903	2.79	148	0.973	0.925	0.878
105	2.932	2.821	2.711	149	0.946	0.9	0.854
106	2.85	2.742	2.634	150	0.919	0.874	0.829

Project ● ●
eürv