



NOT1735
09.24

Saniplus UP



 INSTALLATION INSTRUCTIONS

CE



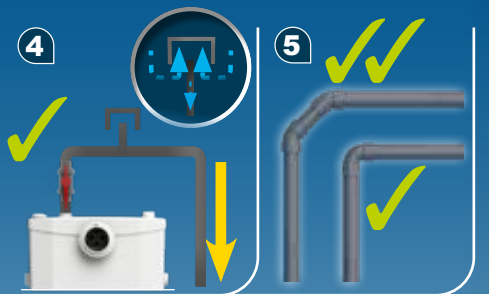
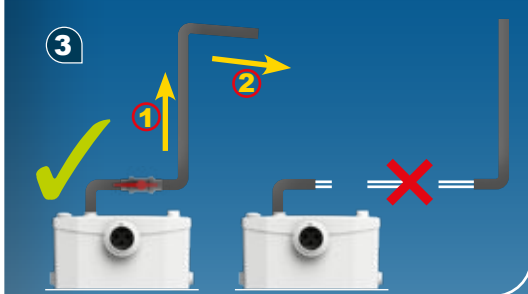
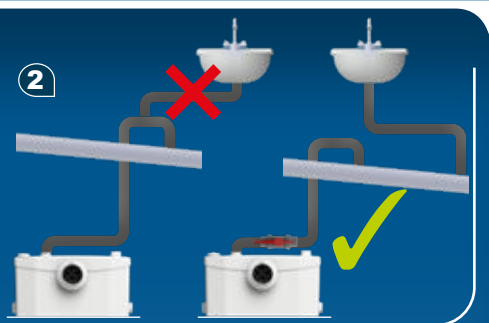
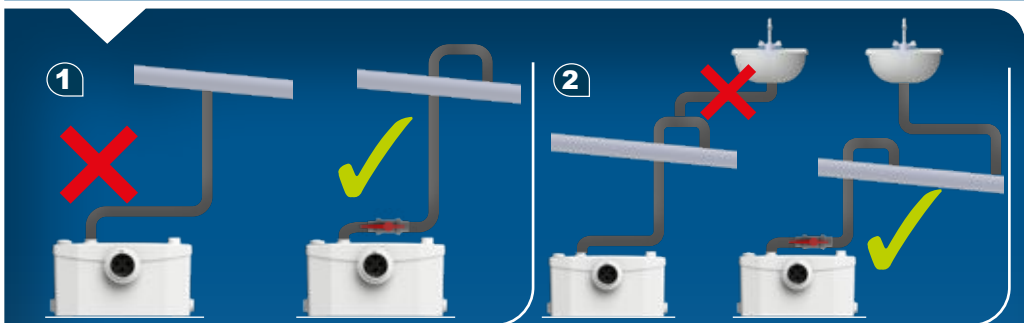
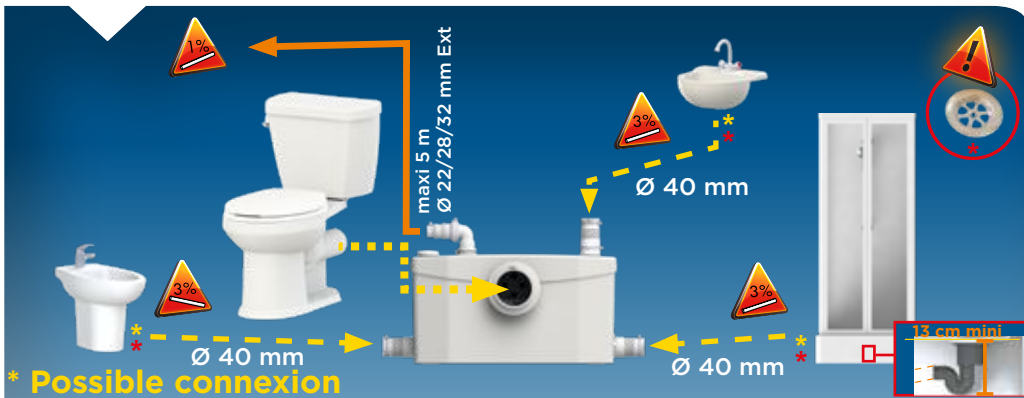

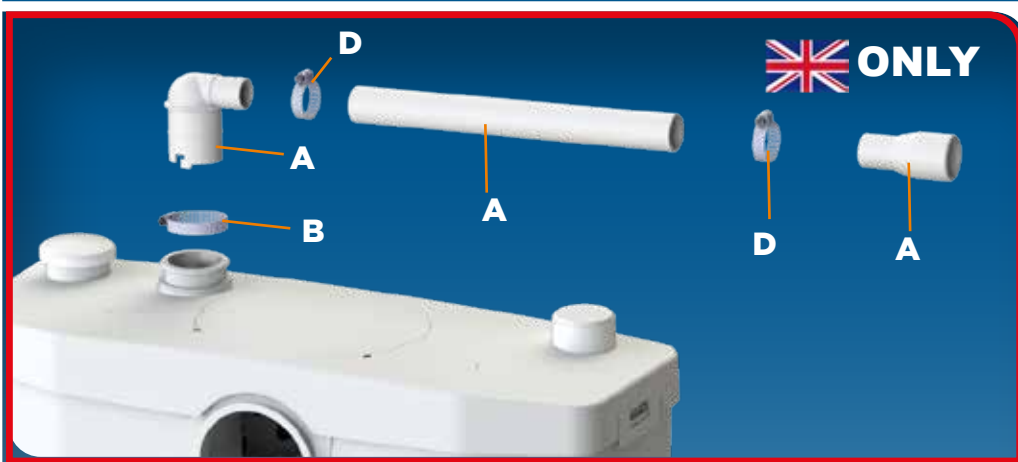
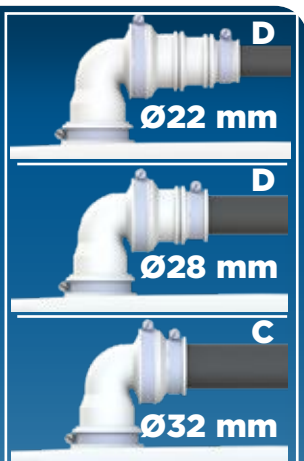
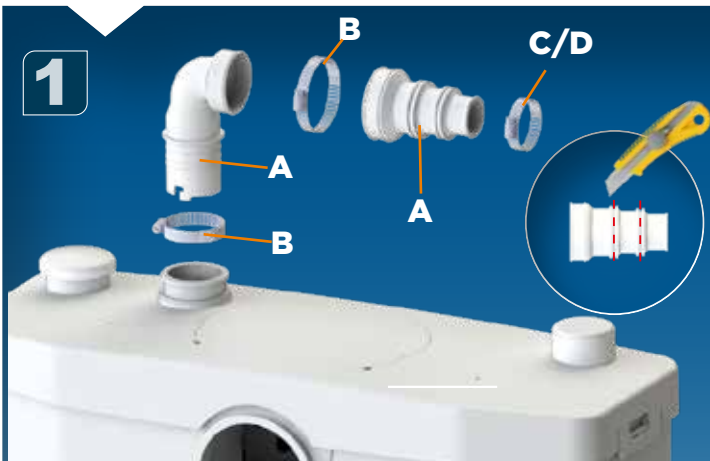
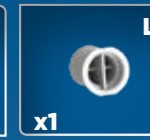
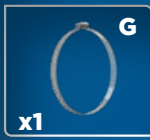
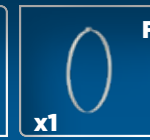
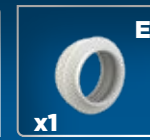
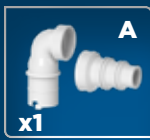

2



3

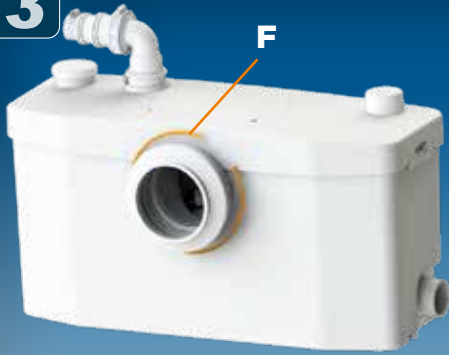

4



5



6



7



8

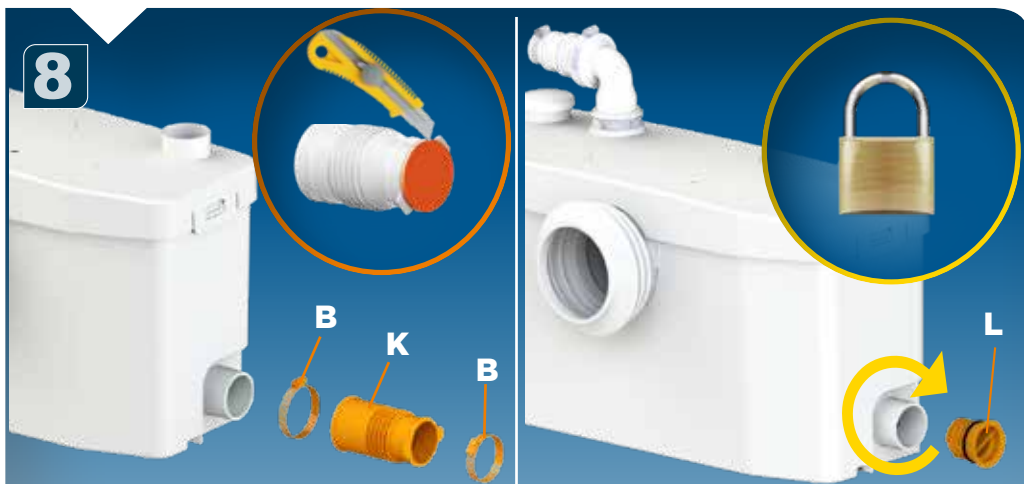

9



1



MAINTENANCE



2



3



4

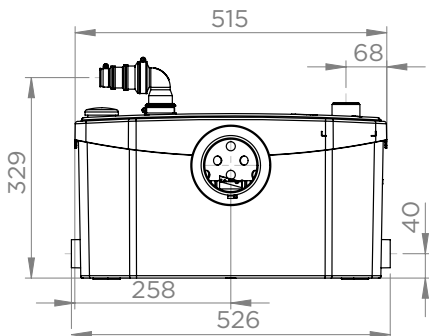
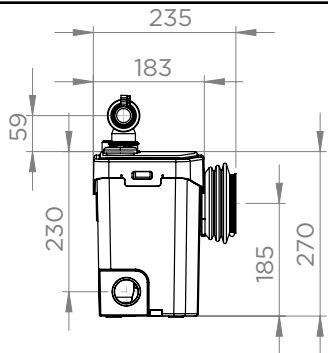

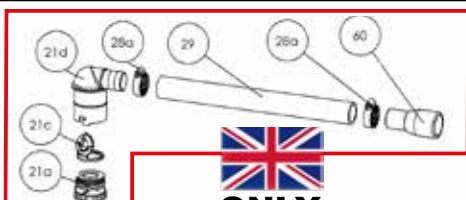

ONLY

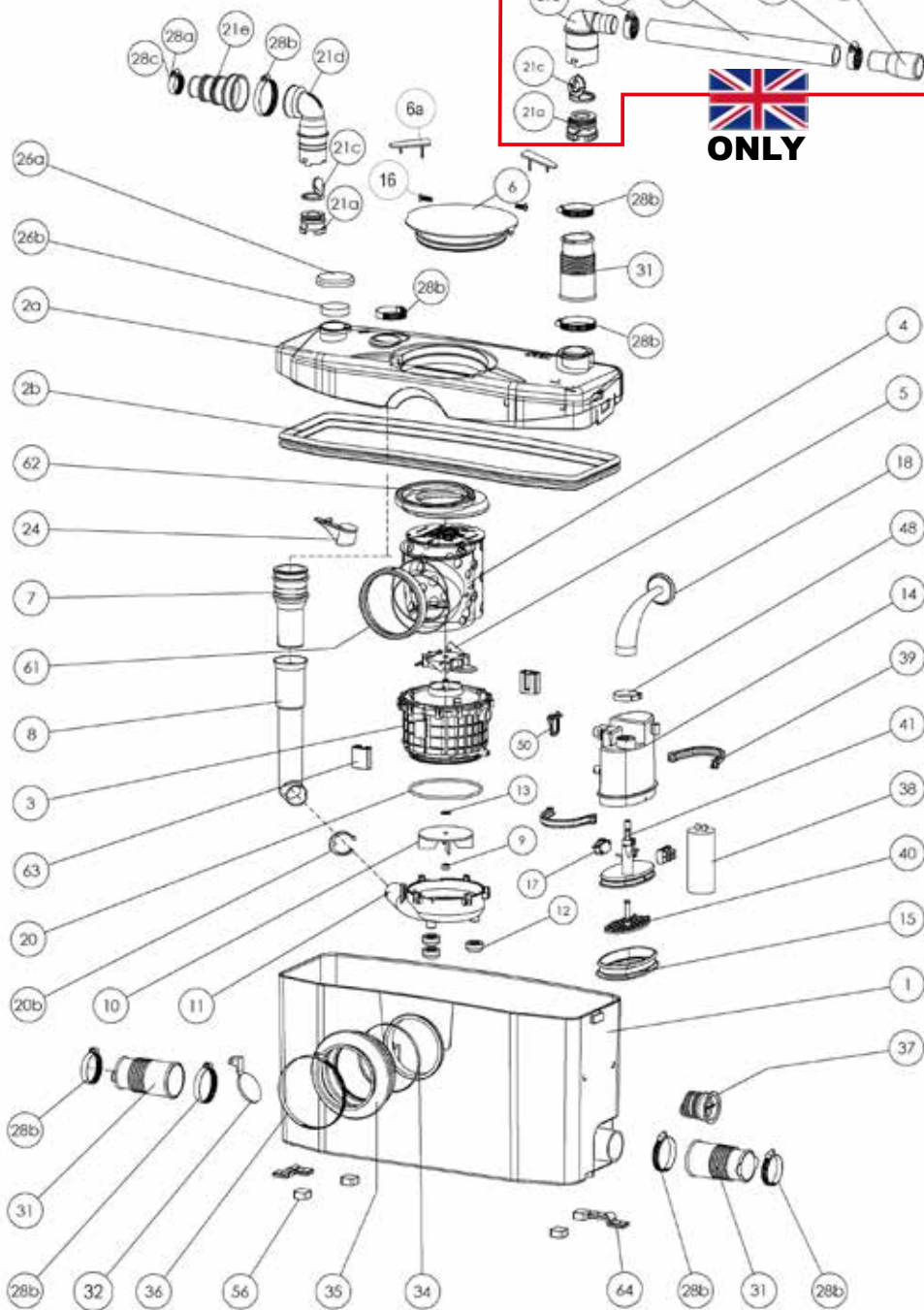

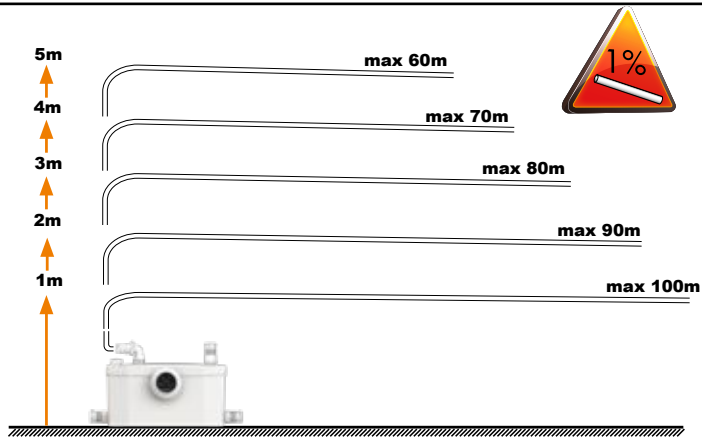
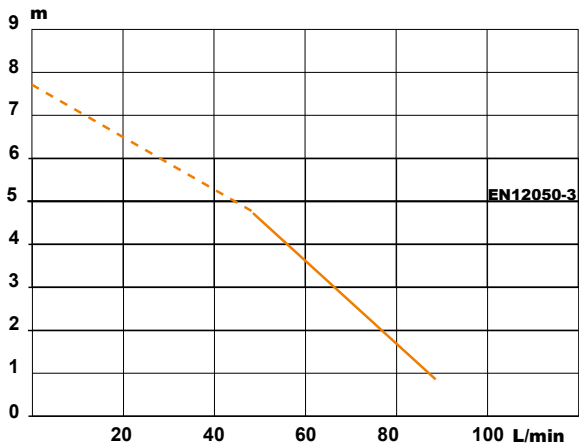

SANIPLUS UP IP68

P30

220-240 V - 50 Hz - 1,9 A - 400 W - IP68 - \oplus - (class 1)

6.4 kG

SERVICE HELPLINES

United Kingdom
Tel. 08457 650011 (Call from a land line)

Ireland
Tel. 1850 23 24 25 (LOW CALL)
Fax. + 353 46 97 33 093

Service information : www.sfa.biz

