

SANTON

Speediboil

Boiling Water 'On Tap'

Drinking Water



Speediboil Boiling Water Heaters

Commercial Boiling Water Heaters – available in 2.5, 5.0 and 7.5 litre capacities

Santon is one of the leading brands in the UK for water heating. For commercial applications, boiling water heaters have a number of advantages over traditional methods. For example, one of our smallest 2.5 litre units can supply over 150 cups of boiling water in one hour. The time saved in constantly boiling kettles to make drinks is vastly reduced, and the time spent waiting for a kettle to boil is removed completely. The Speediboil provides instant hot water.

Performance

Speediboil provides a cost effective solution for a variety of commercial applications including canteens, offices, workshops, hairdressers and waiting rooms.

Installation

Ease of installation has long been a trademark of Santon products and this range is no exception. Full fitting instructions and easily accessible plumbing fittings provide a quick and easy solution.



Technical Specification

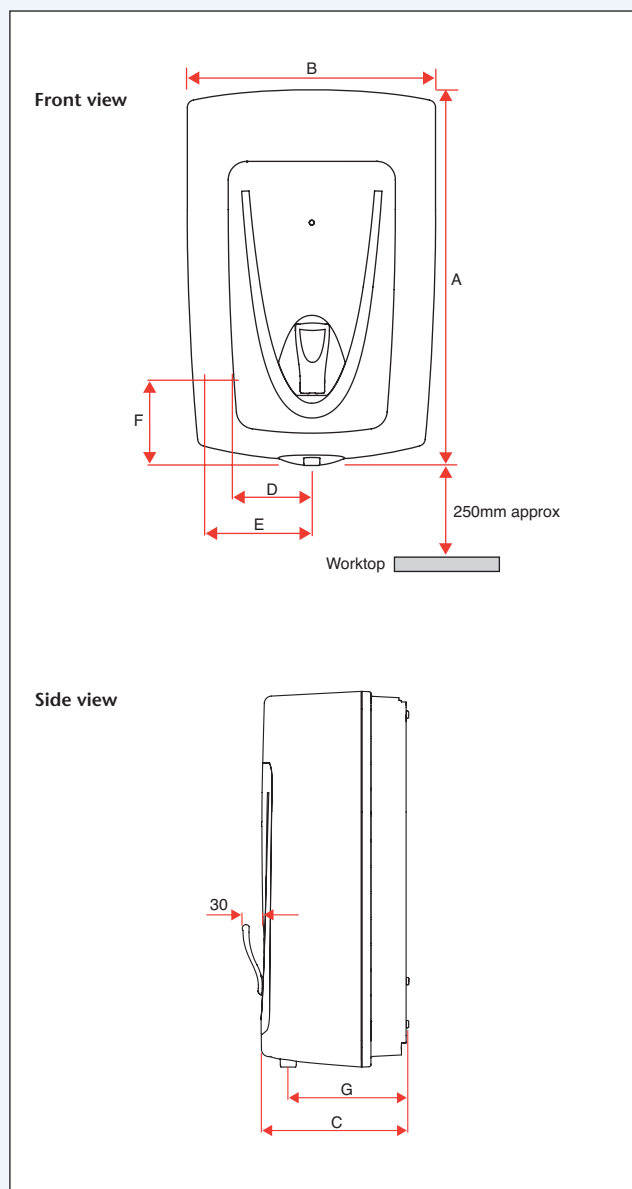

Specification

Ratings

2.5kW @ 240V, all capacities.

Outer Casing

White ABS moulding.

Thermal Insulation

CFC/HCFC free (ODP zero) pre-moulded polystyrene and thermoplastic blend.

Water Container

Moulded Polyphenylene Sulphide. Removable steam condensation chamber for maintenance access.

Heat Unit

Low watts density Superloy element for long life.

Thermostat

Electronic to control water temperature up to boiling point.

Safety Features

All models are low-pressure vented. Dry start protection by self-resetting bi-metal thermal cut-out. Boil dry protection by manually-resettable disc-type bi-metal cut-out.

Installation

Installation

Speediboil units have a fixing template and hook-on brackets for wall mounting, ideally over a draining board or drip-tray. 150mm clearance should be allowed around the unit for maintenance (refer to instructions).

Plumbing

Cold water feed should be taken directly from the mains – min pressure 0.5 bar (7psi) max pressure 10 bar (145psi). Bottom or rear entry using 15mm push-fit connections.

Electrical

Supply (bottom or rear entry) can be taken from a suitable ring final circuit via a fused spur but must be via a double-pole linked isolating switch with a minimum break capacity of 10.5A. All electrical work must comply with the latest IEE wiring regulations.

Approvals

BEAB approved. CE Marked.

Manufactured in the UK in a BS EN ISO 9001:2008, ISO 14001:2004 and BS OHSAS 18001:2007 registered factory.

Guarantee

2 years product guarantee from date of purchase with on-site service support. Full details are contained in the installation instructions supplied with each unit.



Ordering Guide

Model	A (mm)	B (mm)	C (mm)	D (mm)	E (mm)	F (mm)	G (mm)	Weight Full (kg)
2.5 litre	445	290	190	80	115	105	150	8.4
5.0 litre	510	335	200	100	130	105	160	11.8
7.5 litre	510	335	262	100	130	105	230	15.4

Ordering Guide

Capacity of Speediboil	Number of 167ml cups at one time	Number of 250ml mugs at one time	Product Code
2.5 litres	14	10	94 200 001
5.0 litres	29	20	94 200 002
7.5 litres	44	30	94 200 003



heateam is Santon's very own service division. With us on your side, you can be sure that your customers are in the very best hands. Totally committed to quality and safety, heateam is open 7 days a week, for 363 days a year, and offers:

- **Dedicated Trade Advice Line** – our helpful and qualified specialists are always on hand to help you with even the most complex technical query.
- **Installer Priority Call-Outs** – our 280 strong team of specifically trained expert heating engineers covers the UK, no one is better qualified to look after Santon's products for the duration of the guarantee.
- **Fully Stocked Vans** – a nationwide fleet of vans, fully stocked with spare parts – meaning we can repair our appliances on the first visit in 95% of call-outs.
- **Exclusive Service Plans** – heateam also offer Santon's customers a range of exclusive annual service plans.

Opening Times: Monday-Friday 8am-6pm, weekends and Bank Holidays* 8.30am-2pm.

*excluding Christmas Day and New Year's Day.

Simply call **0844 8711535** or visit our website at www.heateam.co.uk



Santon, Hurricane Way, Norwich, Norfolk, NR6 6EA

Specification Advice Hotline

Tel: 01603 420128 Fax: 01603 420229

E-mail: specifier@santon.co.uk

After Sales Service

Tel: 0844 871 1530 Fax: 0844 871 1528

E-mail: santonservice@heateam.co.uk

Website

www.santon.co.uk

The pace of product development is such that we reserve the right to change product specifications without notice. We do, however, strive to ensure that all information in this catalogue is accurate at the time of going to publication.

Products

Unvented Water Heating

PremierPlus | Aquaheat | Aquaheat SS | Aqualine

Solar Unvented Water Heating

PremierPlus Solar

Vented Water Heating

Aquarius | Taps

Drinking Water

Speediboil

Hand Hygiene

EV 2008 | Aqua-dri

Instantaneous Water Heating

PowerPack

Combination Storage

R Unit

Immersion

Industrial