

3 in 1 Single Handle Tap Installation Guide

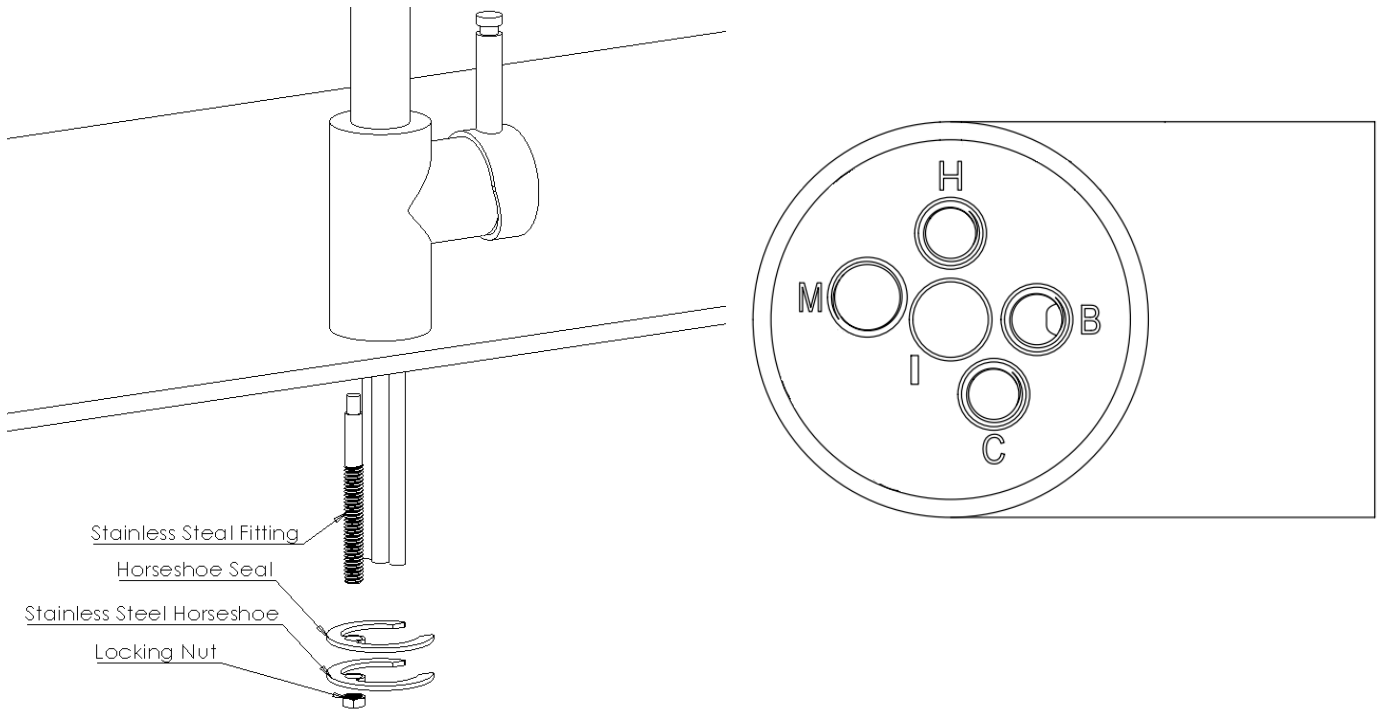

Feed the tails through the countertop and screw fitting into thread 'M'. Slide on horseshoe fittings as shown and tighten with the locking nut.

Fitting	Description
I	Pre-Installed Silicone Hose Connects to Barb Fitting on Boiler Tank with Fixing Clip
B	Flexi Hose (Blue Stripe (Water to Boiler)) Connected 'To' Filter
C	Flexi Hose (Blue Stripe (Max 3Bar)) Connected to Incoming Main Cold
H	Flexi Hose (Red Stripe (Max 3Bar)) Connected to Incoming Domestic Hot
M	Fixing Thread

General care instructions for all kitchen tap finishes

Dry completely with a soft cloth after each use.

Clean regularly with warm water or a mild pH-neutral liquid soap and then polish with a clean, soft, lint-free cloth. A Microfibre cloth is ideal as it is gentle but effective for cleaning without scratching and needs only to be dampened with water to clean the product.

Avoid getting household bleach or cleaners on to your fittings when using on surrounding surfaces. Any splashes should be immediately rinsed with clean water and dried and should not be allowed to remain on the metal finishes.

Under no circumstances should harsh cleaning agents containing acidic, caustic, or abrasive components such as bleach, alcohol or vinegar-based substances be used.

Do not use abrasive cloths, scouring pads, scrub sponges, steel wool etc. as they may damage the surface.

To avoid dye and 'patterning' transfer from wet cloths, avoid hanging them over the spout of the tap. Porous surfaces such as nickel and pewter may be affected by chemicals in or on the cloth.

Failure to Follow These Instructions Could Invalidate Your Warranty

Installation/Maintenance Manual

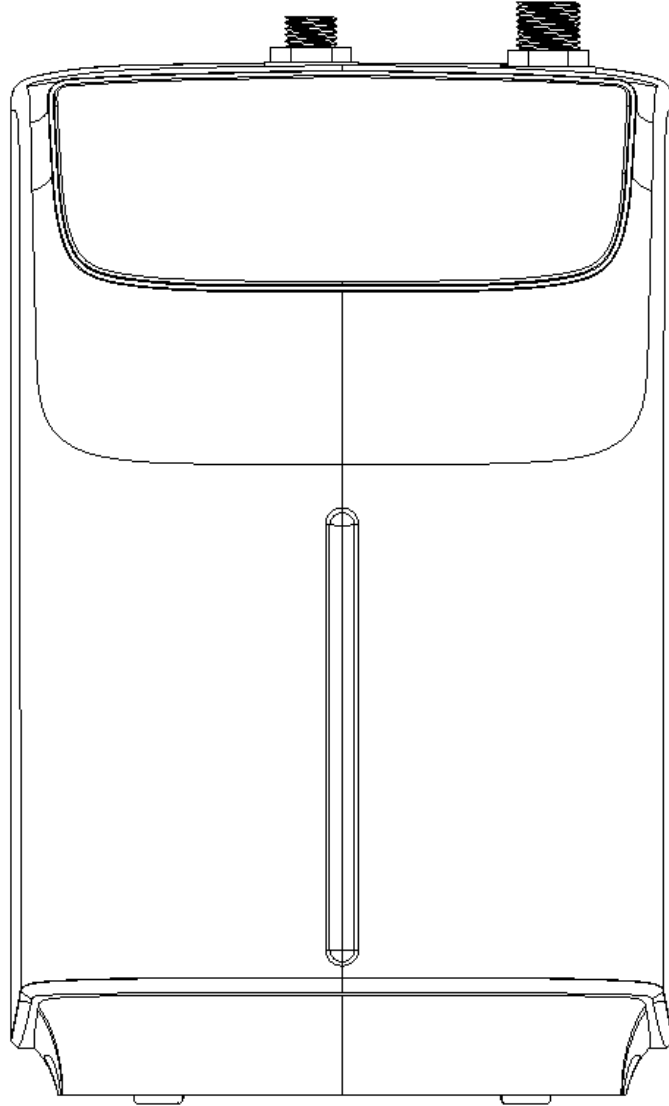

Thank you for purchasing our product; to keep your system compliant and prolong the life, you must read the following instructions carefully & keep up with filter changes as instructed to prevent malfunction

We are delighted that you have chosen our instant boiler and tap. This unique electronic instant hot water appliance will save you time and effort when requiring near boiling water for making tea and coffee and we are sure you will discover many new uses each day.

For your safety, please read and follow our step-by-step guide to the installation, operation and care for the electronic instant hot water appliance and you will soon be making that first cup of coffee or tea from your new appliance.

This electronic instant hot water appliance is not intended for commercial use.

IMPORTANT NOTICE: This product can cause harm if installed incorrectly and should only be installed by a competent person, if you feel for any reason unsure about the installation, please contact a qualified plumber or electrician to install the appliance.

Make sure all electrical wiring and connections conform to local standards.

A standard 220/240v grounded 13 amp switched electrical socket outlet is required within range for the electronic instant hot water appliance.

Alteration to the 13amp fused moulded plug supplied will invalidate your warranty.

Make sure all water connections conform to local standards.

The Maximum working pressure for this system is 3 bar if unsure consult a qualified plumber.

The specific water filter provided with this system is provided to protect the unit only, as well as preventing debris flowing into the system it also helps prevent the build up of scale on the internal components

The water filter must be connected to the electronic instant hot water appliance. Failure to change filter every 6 months (less if you live in a hard water area, check with local water authority) will invalidate your warranty. During any issues proof of purchases for filters will be requested.

The instant hot water appliance is an open vented system appliance it is important never to restrict pipework. The spout acts as the vented outlet.

⚠ WARNING

Failure to follow the above advice and the following instructions will invalidate your warranty.

PLEASE READ ALL INSTRUCTIONS CAREFULLY

When using all electrical appliances, basic safety precautions should always be followed including the information below:

⚠ DANGER

To protect against electrical shock, do not place cord, plugs or unit near or in water or other liquids and do not operate the electronic instant hot water appliance controls or power socket with wet hands.

Check the power rating of your electronic instant hot water appliance is suitable for the power rating of the electrical circuit it is being installed on.

Do not operate or install the electronic instant hot water appliance if it appears to have missing parts, be damaged / faulty e.g., damaged cord, plug.

Do not use outdoors or in a damp area.

Do not use the electronic instant hot water appliance for anything other than the intended **Domestic** use.

The electronic instant hot water appliance must be installed vertically as shown on front cover with inlet and outlet connections at the top of appliance.

Ensure the front of the unit is visible, unobstructed and the front controls can be easily reached.

Do not attempt to open, modify or service this electronic instant hot water appliance. Repairs should be carried out by Authorised Service personnel. Opening the unit will void the guarantee.

For servicing purposes, the services provided by the customer should have means of isolation. These should terminate with ½" BSP male fitting for the hot female and a ½" BSP male thread that can accept a flat face for both main feeds.

A switched socket outlet is required to power up the boiler tank, this must be fitted in accordance with the current IET Wiring Regulations.

This electronic instant hot water appliance is not intended for use by persons (including children) with reduced physical, sensory, or mental capabilities, or lack of experience and knowledge, unless they have been given supervision or instruction concerning use of appliance by a person responsible for their safety. Children should be supervised to ensure that they do not play with the electronic instant hot water appliance or instant hot water tap, a safety spring back is used to control the flow of the near boiling water for additional safety.

PLEASE READ ALL INSTRUCTIONS PRIOR TO INSTALLATION.

Installation

When installing the electronic instant hot water appliance, provide approximately 10cm to 15cm of air space on the sides of the unit for air circulation and approximately 2.5cm from the rear surface.

The environment humidity should be in the range of 10% to 60%. Be sure there is no dew.

Do not power up the boiler tank until all pipework is complete and checked to ensure there are no leaks.

It is recommended that a qualified person installs this system.

Install the tap using the instructions provided with the tap.

Position the boiler tank in a suitable position close to the tap, ensuring that the silicone hose **(10)** can be connected without being stretched, restricted, or twisted.

Make sure the filter is fitted close to the boiler tank allowing space for a small amount of pipe between the filter and the boiler tank.

The boiler tank is fitted with a 3/8" male thread for outlet and a 1/2" male thread for the inlet.

Fasten the 1/2" Female BSP to 6mm Push Fit **(6)** to the to the inlet of the boiler tank (Blue). Do not over tighten as this will cause the washer to split and the system will leak.

Fasten the 3/8" to Barb **(8)** to the outlet of the boiler tank (Red), making sure to include the washer **(9)**. Do not over tighten as this will cause the washer to split and the system will leak.

The incoming mains cold & domestic hot water supplies should have isolation means and terminate with ½" BSP male threads, close to the tap flexible tails.

Fasten the Flexi Hose (Blue Stripe (Max 3Bar)) **(1)** to the incoming main cold with a wrench.

Fasten the Flexi Hose (Red Stripe (Max 3Bar)) **(2)** to the incoming domestic hot with a wrench.

Fasten the Flexi Hose (Blue Stripe (Water to Boiler)) **(3)** to the 1/2" Male BSP to 6mm Push Fit **(4)**.

Ensure the hoses have no twists or kinks and do not overtighten when fastening.

The 1m PE Pipe **(5)** must be cut into two lengths before installation. The length will depend on your positioning of the filter and boiler tank. When cutting the PE pipe make sure there is no swarf in the pipe as this **will** restrict flow through the boiler tank.

You will need to run the first length of the PE pipe from the 1/2" Male BSP to 6mm Push Fit **(4)** to the filter.

Then run the other length of the PE pipe from the filter to the 1/2" Female BSP to 6mm Push Fit **(6)** on the boiler tank.

To secure the PE Pipe into the push fit pieces, push into the hole until it stops. Then pull it to make sure it is fitted properly.

Attach the Pre-Installed Silicone Hose **(10)** to the Barb Fitting **(8)**. Make sure the hose is snug around the fitting and secure by sliding the fixing clip **(9)** over the barb. DO NOT reduce the length or extend the Pre-Installed Silicone Hose.

Priming

Before powering up the boiler tank you must first prime the boiler tank and make sure there are no leaks.

Open the isolation valves attached to the mains supply to allow water flow. Then press and turn the hot water handle on the tap until water begins to flow from the spout. This may take around 90 seconds. The water will not be hot as we haven't supplied power to the tank yet.

Please ensure that water is flowing from the tap before turning on the boiler to ensure the unit is filled fully before heating the water.

Due to the system being an open vented system, it requires the safety mechanism to be operated to introduce new water to the system.

The boiler tank is now primed.

Check all connections for leaks. If there is a sign of leakage, make sure the connection has been tightened sufficiently. Press and turn the hot water handle again to ensure all leaks have been dealt with.

If you try to power on the tank before priming the display will read an 'E3' error message. This is because there is no water in the tank.

Powering On

Connect the plug to a nearby power socket and turn on at the switch.

Touch the illuminated, red on/off button

You should begin to see activity on the display of your boiler tank.

The left of the display will show the current temperature of the water inside the tank. The right of the display will show the temperature it is set to heat up to.

As a safety feature, the tank will not begin heating up until you chose a desired temperature by toggling the illuminated red 'Set Temp.' button until you reach the temperature you want. Available temperatures are, 75°C, 85°C, 90°C, 95°C or 98°C. This will only be required during set up or when it is powered on again.

Once heating has started the display will flash, the left-hand temperature will rise until it matches the set temp.

If you see an error message on the display 'E4' then please unplug and plug the boiler back into the power socket. If the issue persists, please contact the service centre.

If the tank is left on but has no water inside, then the boiler tank will automatically shut off after 5 minutes until it has been primed again using the instructions set out earlier.

When the water inside the boiler tank drops 2° below the temperature threshold, it will automatically begin to reheat the water till it reaches the set target.

If the electronic instant hot water appliance is not being used for long periods of time i.e.:

Over 7 days, to save power we recommend you switch off using “ON/OFF” switch.

Prior to turning back on, operate the handle for 3 minutes to allow fresh water to flow through the system.

Over 14 days, follow the Environment guidelines and disconnect the tank.

Environment

The boiler tank must not be exposed to below freezing temperatures. If for whatever reason, there is a possibility of this happening you must drain the system of water. Shut off the mains and isolate the boiler tank system. Disconnect from the power supply and allow the tank to cool for at least 1 hour. Once cooled, disconnect the inlet supply and tip upside down into the sink to empty of water.

To reinstall, repeat installation instructions above.

You should regularly perform visual checks on the operation of the tank and look for any leaks in the system. If you find a leak you may either need to re-tighten the connections or replace any split rubber washers, silicone tubes, or flexi tails that may be causing the leaks.

Filter replacement indicator

To the right of the display shows the life consumed of the filter, gradually the bars will illuminate, starting with green. If you live in a hard water area, once the 4th bar illuminates the filter should be changed, for other areas the filter must be changed when the 6th red bar first becomes illuminated.

Reset Life of Filter

After changing the filter with a new one, Press and hold on the ‘Set Temp’ button for around 5 seconds until a beep sound is heard and the bar showing on the display disappears, the life of filter is reset.

PROBLEM	POSSIBLE CAUSE	WHAT TO DO
Water and Steam is spitting from the instant hot water tap spout	Faulty Component	Turn off the unit and contact the manufacturer
	Limescale Build up, due to lack of filter change	
	Air in the system	See guide on page 7
Water is not hot	The electronic instant hot water appliance is unplugged	Make sure the electronic instant hot water appliances plugged in and connected to a grounded electric outlet
		Make sure that the circuit breaker and fuse are working correctly

Water is too hot	Water temperature setting is set to high temperature	Re-set the temperature to the lower temperature
Water is dripping from the instant hot water tap spout.	The expansion chamber isn't draining the system correctly due to very small draw off water	Draw off 0.5L of water to clear and prime the system. Avoid less than 150ml draw offs of water
	The spout is blocked	Remove and clean the aerator
	Air in the system	Follow guide on next page
Slow flow from the spout	Water filter may be clogged from impurities in the inlet mains water	The water filter must be changed every 6 months or less if in a hard water area, otherwise this will void the guarantee
	Limescale Build up	
Water does not flow straight away	The electronic instant hot water appliance is designed for non-pressurised operation and there will be a slight delay till the near boiling water appears	After a large volume of water has been drawn off there may be a slightly longer delay in the water appearing from the instant hot water tap spout
No water flowing	Water valves have been turned off	Turn on all water valves
No water flowing	Inlet pipes have been blocked or twisted	Ensure the pipes are non-twisted or kinked to restrict flow
		Remove and clean the aerator
		Remove the electronic instant hot water appliance as per the descaling instructions and flush through all pipes to ensure water flow

PROBLEM	WHAT TO DO
Water continues to flow more than 5 seconds after handle release	<p>It is advisable to isolate the water supply to the 3 in 1 tap before commencing, prior to doing so fill a pouring jug with water (this will be needed at a later stage to prime the filter)</p> <p>The next step would be to remove the filter from its housing by twisting, have a cloth at hand to place under the filter housing to collect any excess water (the amount of water should be minimal)</p> <p>Hold the filter in the sink and slowly pour water into the top opening, as you are doing this, air bubbles will probably be visible, continue until the air bubbles disappear (1 litre of water should suffice, be sure to pour slowly)</p> <p>Keeping the filter upright slowly replace into the housing, twisting until the arrows line up.</p>
PROBLEM CAUSE	Turn the water supply to the 3 in 1 tap back on and test the flow, the problem should now be solved.
Air Trapped Inside Filter	<p>It is advisable to operate taps slowly when first used after the water supply has been isolated, to avoid splashing from the mixture of air and water!</p> <p>Once the filter has been primed the problem should not return, due to the fact that the water heater has an internal expansion vessel to cope with the water temperature rise, on rare occasions air can be trapped which gradually makes its way to the filter. Generally, all air is pushed out of the system on the initial install or within 24hrs, but it is not uncommon for air to be trapped for up to several weeks.</p>

Disclaimer

In extremely rare circumstances, there is a possibility for the unit to over boil, overheat or produce steam. In this event, ensure to immediately turn off the unit. If it is safe to do so, operate the boiler handle to reduce the steam and stop the heating process (there may still be some steam present during the start of the process) and contact the manufacturer – Ellsi Limited as listed on the label on the rear of the unit.

Ellsi Limited, Flixborough industrial estate, Scunthorpe, dn15 8sl

For Safety, steam may be produced via the spout for up to 15 minutes before the safety overrides will stop power to the unit. This is to comply with G3 of the Building Regulations

Guarantee

We take special care to select high quality materials and use manufacturing techniques that allow us to create products incorporating design and durability. This boiler has a manufacturer’s guarantee of 2 years against manufacturing defects, from the date of purchase (if bought in store) or date of

delivery (if bought online), at no additional cost for normal (non-professional or commercial) household use.

To make a claim under this guarantee, you must present your proof of purchase and proof of filter purchases/changes (this may also include others such as a sales receipt, purchase invoice or other evidence admissible under applicable law), please keep your proof of purchase in a safe place. For this guarantee to apply, the product you purchased must be new, it will not apply to second hand or display products. Unless stated otherwise by applicable law, any replacement product issued under this guarantee will only be guaranteed until expiry of the original period guarantee period.

This guarantee covers product failures and malfunctions provided the product was used for the purpose for which it is intended and subject to installation, cleaning, care and maintenance in accordance with the information contained in these terms and conditions, in the user manual and standard practice, provided that standard practice does not conflict with the user manual.

This guarantee does not cover defects and damage caused by normal wear and tear or damage that could be the result of improper use, faulty installation or assembly, neglect, accident, misuse, or modification of the product.

Unless stated otherwise by applicable law, this guarantee will not cover, in any case, ancillary costs (shipping, movement, costs of uninstalling and reinstalling, labour etc), or direct and indirect damage. If the product is defective, we will, within a reasonable time, replace or refund.

Rights under this guarantee are enforceable in the country in which you purchased this product. Guarantee related queries should be addressed to the store you purchased this product from. The guarantee is in addition to and does not affect your statutory rights.