

**STUART**

**PH 45 ES CI, PH 75 ES CI, PH 95 ES CI Pumps**

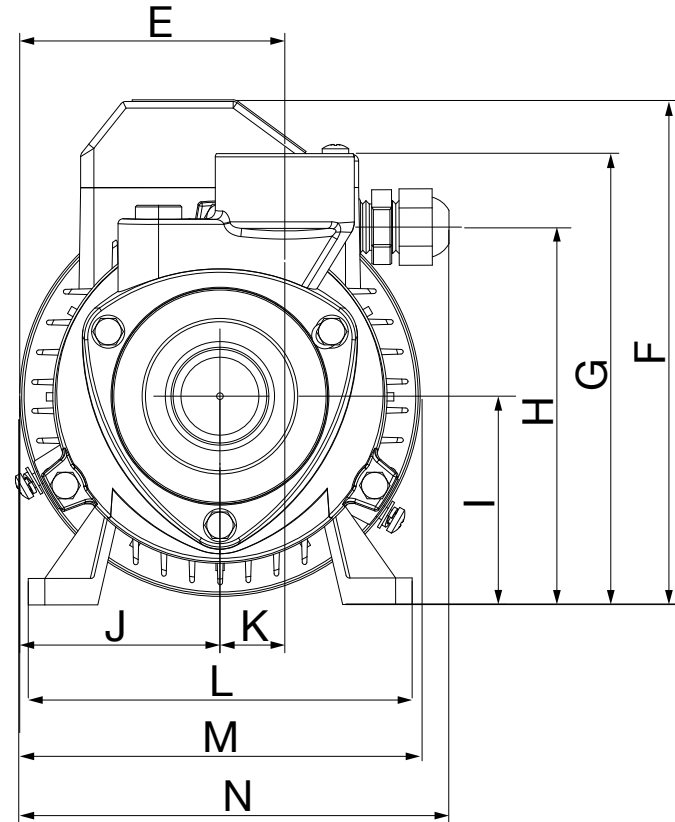
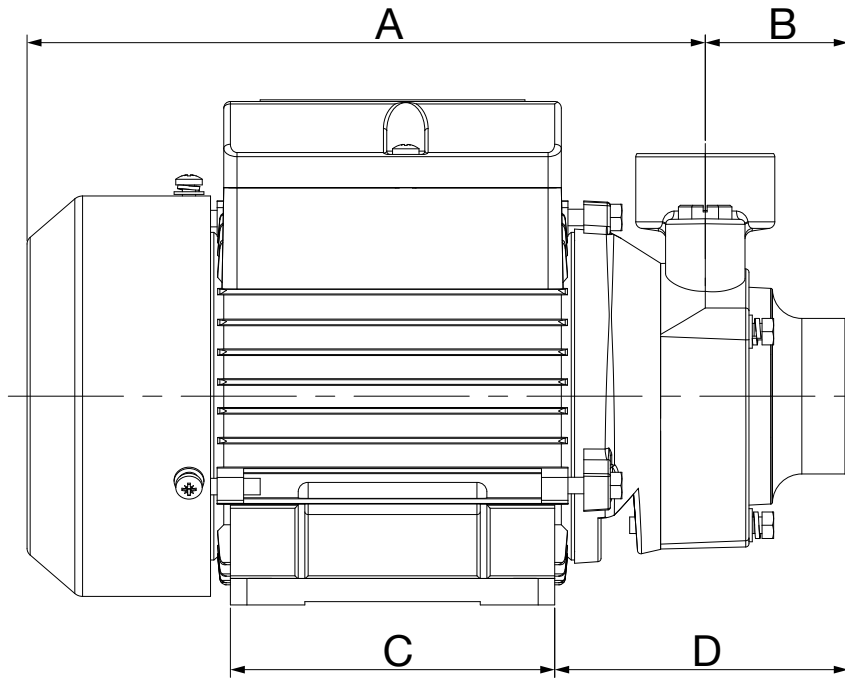

| Model    | PH 45 ES CI | PH 75 ES CI | PH 95 ES CI |
|----------|-------------|-------------|-------------|
| Dim. 'A' | 205         | 234         | 234         |
| Dim. 'B' | 43          | 49          | 46.5        |
| Dim. 'C' | 98          | 112         | 112         |
| Dim. 'D' | 89          | 101         | 98.3        |
| Dim. 'E' | 80.1        | 93.5        | 88.6        |
| Dim. 'F' | 152         | 177         | 177         |
| Dim. 'G' | 136         | 154         | 157         |
| Dim. 'H' | 114         | 134         | 134         |
| Dim. 'I' | 63          | 71          | 71          |
| Dim. 'J' | 60.5        | 70.5        | 70.5        |
| Dim. 'K' | 19.6        | 23.5        | 18.5        |
| Dim. 'L' | 116         | 134         | 134         |
| Dim. 'M' | 121         | 140         | 140         |
| Dim. 'N' | 130         | 145         | 145         |

Dimensions in millimetres

Stuart Turner Ltd own the copyright within this document. The document may be printed for personal use only. The document must not be altered, reproduced or utilised in any way without written permission from Stuart Turner Ltd, Henley-on-Thames, Oxfordshire, RG9 2AD, England. Stuart Turner Limited reserves the right to amend specifications without notice.

Stuart Turner Ltd, Henley-on-Thames, Oxfordshire RG9 2AD Tel: +44 (0) 1491 572655 Fax: +44 (0) 1491 573704

TechAssist Helpline +44 (0) 800 969 80

www.stuart-turner.co.uk

Issue: 2119/1