

stuart

Diver 35 & Diver 45 Submersible Pumps

The Diver 35 & Diver 45 submersible pumps offer a solution to lifting clean fresh water for high head (pressure) requirements.

Incorporating a floating switch to protect against running dry, these products feature stainless steel motor shells and are compact and easy to install.

Boostamatic options are also supplied with an automatic control module.



Diver 35 & 45

Diver 35 & 45 Boostamatic



Features

- Fully automated - no switch setting necessary
- A built in 'no water' safety cut out
- No pulsing when operating
- Nitrile/carbon/ceramic long life seal
- Stainless steel motor shell
- External float switch
- 25 mm hose connector
- Boostamatic control module options

Application

- These pumps are ideal for clean water applications where pressure is needed, such as sprinklers or pumping up to storage tanks
- Boostamatic control module options are ideal for irrigation or water supply applications where the pump can be located in a well or pond for example

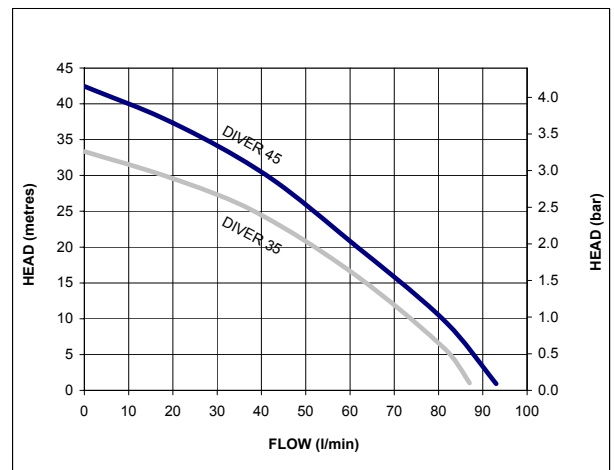

For further advice on selecting the correct pump call or e-mail info@stpumps.co.uk

pumpassist
HELPLINE +44 (0) 844 98 000 97

stuart

Pump Model		Diver 35 46585	Diver 45 46586	Diver 35 Boostamatic 46611	Diver 45 Boostamatic 46612
General	Guarantee	1 year			
Features	Pump type	Submersible			
	Mechanical seal	Nitrile / Carbon / Ceramic			
	Automatic and manual mode	✓	✓	✓	✓
	Automatic float switch	✓	✓	✓	✓
	Control module	n/a	n/a	✓	✓
Performance	Maximum head (closed valve)	34 metres	42 metres	34 metres	42 metres
	Maximum immersion depth	10 metres			
	Minimum immersion depth	300 mm			
	Performance @ 20 l/min	29 metres	35 metres	29 metres	35 metres
	Performance @ 60 l/min	15 metres	21 metres	15 metres	21 metres
	Maximum flow	88 l/min	94 l/min	88 l/min	94 l/min
	Min / Max water temperature	Min 4 °C / Max 35 °C			
Connections	Pump connections	G 1 female			
	Control module (Boostamatic only)	n/a		G 1 male	
	Hose Connector	25 mm male			
Motor	Type	Induction, auto-reset thermal trip			
	Duty rating	Continuous			
Electrical	Power supply / phase / frequency	230 V a.c. / 1 / 50 Hz			
	Current (full load)	3.7 Amps	4.7 Amps	3.7 Amps	4.7 Amps
	Power consumption	774 Watts	1012 Watts	774 Watts	1012 Watts
	Fuse rating	13 Amps			
	Power cable (pre-wired)	15 metres			
Physical	Enclosure protection	IPX8			
	Width	164 mm			
	Height (excluding hoses)	350 mm	387 mm	350 mm	387 mm
	Weight (including fittings)	8.7 Kg	9.2 Kg	8.7 Kg	9.2 Kg

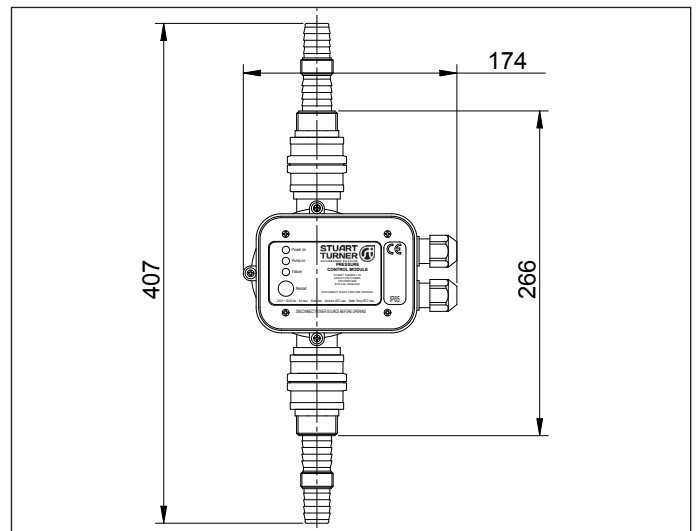
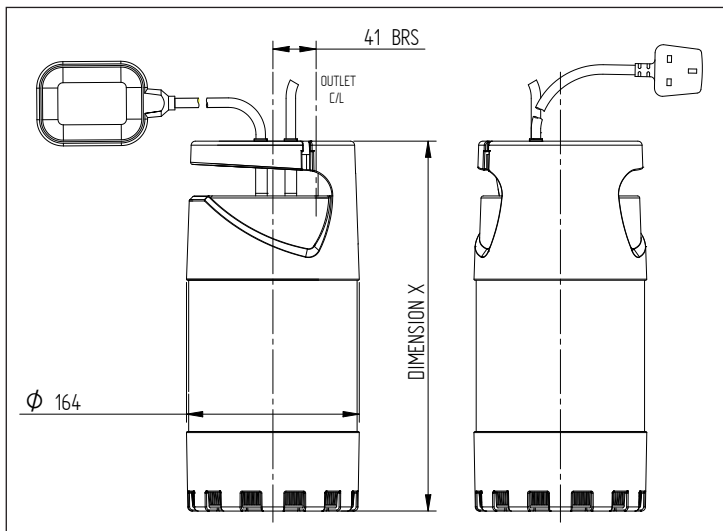

Pump Description	Dim. 'X'
Diver 35 / Diver 35 Boostamatic	350 mm
Diver 45 / Diver 45 Boostamatic	387 mm

Diver 35 Boostamatic Control Module
Diver 35 Boostamatic Control Module

Stuart Turner Limited reserves the right to amend specifications without notice.