

STORMBOOST

Mains Boosting Pump

STORMBOOST boosts existing mains water pressure by up to 2.5 bar and a maximum flow rate of 12 litres per minute.

The **STORMBOOST** Pump is designed to be connected directly to the incoming cold water mains and activates automatically when a tap is opened or a shower is switched on, boosting mains water pressure and flow throughout the property.

Featuring a highly reliable induction motor and a high quality brass pump head, **STORMBOOST** is supplied with two anti-vibration connection hoses and an extended 5 year warranty.



Features

- 5 year warranty
- Mains pressure boosted by up to 2.5 bar
- Max pump output flow rate of 12 litres/min
- Patented integral bypass
- Switches on/off automatically
- High quality, robust brass pump body and impeller
- Anti-vibration connection hoses included
- Quiet operation
- Dry run protection

Applications

- Boosting mains water pressure to properties using a combi-boiler
- Ideal for properties with a single bathroom

Performance

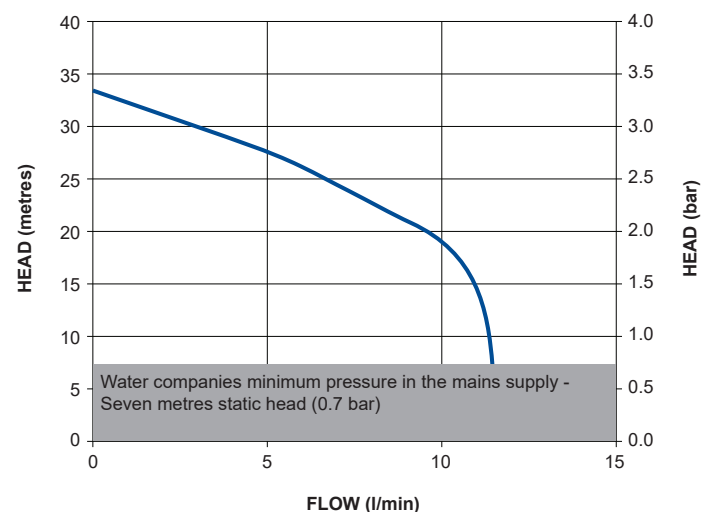

Model		STORMBOOST 47708
General	Warranty	5 years (upon registration with proof of purchase)
	WRAS	WRAS Approved Product
	Kiwa	Kiwa Reg 4 Certified
	Conformity certification	UKCA CE
Technical Features	Pump type	Peripheral
	Mounting	Floor or plinth
	Anti-vibration feet	●
	Anti-vibration flexible hoses	●
	Dry run protection	●
	Typical noise*	48 dB(A)
Performance	Maximum head – closed valve	3.2 bar (32 metres)
	Maximum flow	12 litres/min
	Maximum working pressure**	600 kPa (6.0 bar)
	Max ambient air temperature	40 °C
	Min / Max water temperature	Min 4 °C / Max 23 °C
	Flow switch sensitivity	0.6 litres/min (approx)
Construction	Pump head	Brass
	Pump impeller	Brass
	Pump head mechanical seal	EPDM / PTFE / Al Oxide
Connections	Pump inlet / outlet	G ¾ M
	Anti-vibration hoses	G ¾ F – 15mm push-fit (205 mm long)
Motor	Type	Induction (thermal trip/auto reset)
	Duty rating	Continuous (S1)
Electrical	Power supply (Vac/Ph/Hz)	165–265 V a.c. / 1 / 50–60 Hz
	Power consumption (P1)	340 Watts
	Current (full load)	1.5 Amps
	Fuse rating	5 Amps
	Power cable length	1.5 metres
Physical	Enclosure protection	IPX4
	Length	215 mm
	Width	148 mm
	Height – excluding hoses	262 mm
	Weight – including fittings	6.2 kg

* The equivalent continuous A-weighted sound pressure level at a distance of 1 metre from the pump.

** The maximum pressure that can be applied to the pump under any installation conditions.

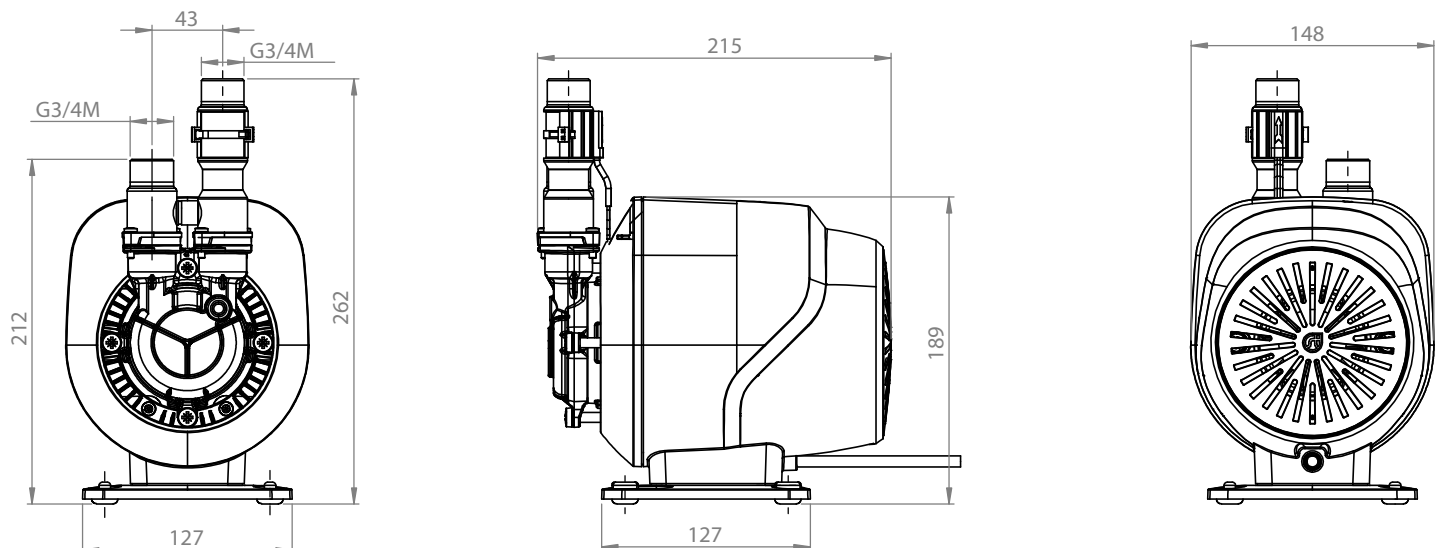

Stuart Turner Limited reserves the right to amend specifications without notice.

Stuart Turner Ltd, Henley-on-Thames, Oxfordshire RG9 2AD Tel: +44 (0) 1491 572655

TechAssist Helpline +44 (0) 800 31 969 80

www.stuart-turner.co.uk

Issue 2024-01-01