

# ecoFIT pure

412 - 435

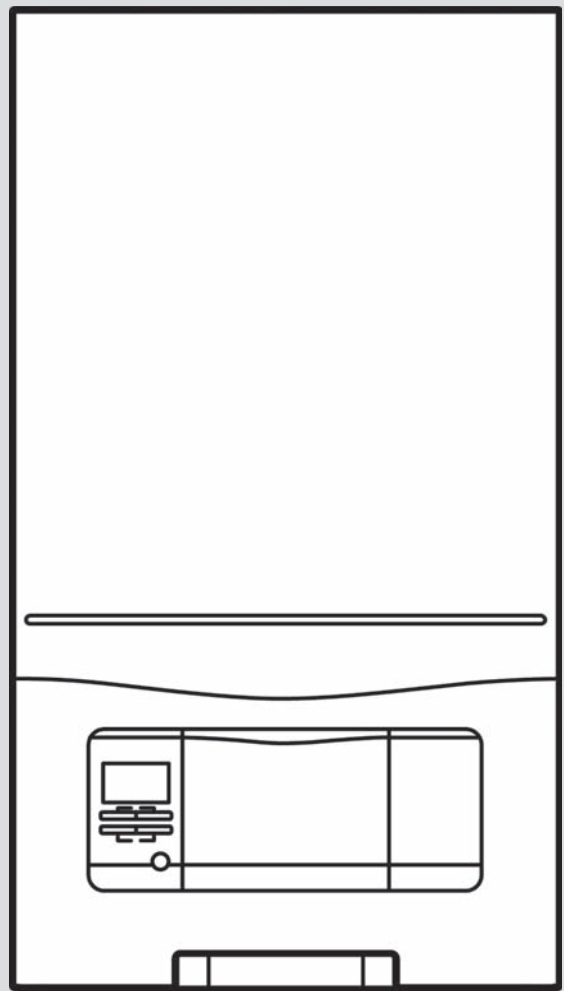

# Installation and maintenance instructions

## Contents

<b>1</b>	<b>Safety</b> .....	<b>3</b>	9.3	Filling the condensate trap .....	28
1.1	Intended use .....	3	9.4	Switching on the product .....	28
1.2	Qualification .....	3	9.5	Flushing the heating installation for the first time ("cold") .....	28
1.3	General safety information .....	3	9.6	Filling the heating installation .....	28
1.4	Regulations (directives, laws, standards) .....	5	9.7	Checking the gas setting .....	28
1.5	List of relevant standards for Great Britain and Ireland .....	5	9.8	Thoroughly flushing the heating installation ("hot") .....	30
<b>2</b>	<b>Guarantee and Customer Service</b> .....	<b>6</b>	9.9	Checking leak-tightness .....	30
<b>3</b>	<b>Technical data</b> .....	<b>7</b>	9.10	Checking the heating mode .....	30
<b>4</b>	<b>Notes on the documentation</b> .....	<b>11</b>	<b>10</b>	<b>Adapting the unit to the heating installation</b> .....	<b>30</b>
<b>5</b>	<b>Product description</b> .....	<b>11</b>	10.1	Burner anti-cycling time .....	30
5.1	CE marking .....	11	<b>11</b>	<b>Handing over to the end user</b> .....	<b>31</b>
5.2	Hot Water Association .....	11	<b>12</b>	<b>Inspection and maintenance</b> .....	<b>32</b>
5.3	Information on the data plate .....	11	12.1	Complete Service Interval Record section .....	32
5.4	Functional elements .....	12	12.2	Using original seals .....	32
5.5	Safety Devices .....	12	12.3	Observing inspection and maintenance intervals .....	32
<b>6</b>	<b>Set-up</b> .....	<b>13</b>	12.4	Checking the CO <sub>2</sub> content .....	32
6.1	Checking the scope of delivery .....	13	12.5	Setting the CO <sub>2</sub> content .....	32
6.2	Dimensions .....	13	12.6	Removing the gas-air mixture unit .....	32
6.3	Installation site .....	13	12.7	Cleaning the heat exchanger .....	33
6.4	Minimum clearances .....	14	12.8	Checking the burner .....	33
6.5	Air/flue pipe .....	14	12.9	Checking the ignition electrode .....	33
6.6	Using the mounting template .....	17	12.10	Cleaning the condensate trap .....	34
6.7	Wall-mounting the product .....	17	12.11	Installing the gas-air mixture unit .....	34
6.8	Removing/installing the front casing .....	18	12.12	Completing inspection and maintenance work .....	34
6.9	Removing/installing the side section .....	18	<b>13</b>	<b>Troubleshooting</b> .....	<b>34</b>
<b>7</b>	<b>Installation</b> .....	<b>19</b>	13.1	Eliminating faults .....	34
7.1	Preparing for installation .....	19	13.2	Calling up and clearing the fault memory .....	34
7.2	Installing the heating pump .....	19	13.3	Resetting parameters to factory settings .....	34
7.3	Heating water supply in the open heating system .....	19	13.4	Preparing the repair work .....	34
7.4	Heating water supply in the sealed heating system .....	20	13.5	Replacing defective components .....	35
7.5	Connecting the heating flow and heating return .....	20	13.6	Checking the product for leak-tightness .....	36
7.6	Check compliance with the local gas group .....	20	<b>14</b>	<b>Decommissioning the product</b> .....	<b>36</b>
7.7	Gas connection .....	21	<b>15</b>	<b>Recycling and disposal</b> .....	<b>36</b>
7.8	Connecting the condensate discharge pipe .....	21	<b>Appendix</b> .....	<b>37</b>	
7.9	Flue installation .....	23	<b>A</b>	<b>Inspection and maintenance work</b> .....	<b>37</b>
7.10	Electrical installation .....	23	<b>B</b>	<b>Overview of diagnostics codes</b> .....	<b>38</b>
<b>8</b>	<b>Operation</b> .....	<b>26</b>	<b>C</b>	<b>Status codes – Overview</b> .....	<b>41</b>
8.1	Operating concept .....	26	<b>D</b>	<b>Overview of fault codes</b> .....	<b>42</b>
8.2	Installer level overview .....	26	<b>E</b>	<b>Wiring diagram</b> .....	<b>44</b>
8.3	Calling up the installer level .....	26	<b>F</b>	<b>Wiring diagram, 30 kW</b> .....	<b>45</b>
8.4	Live Monitor (status codes) .....	26	<b>G</b>	<b>Commissioning Checklist</b> .....	<b>46</b>
8.5	Using check programmes .....	26	<b>H</b>	<b>Commissioning Flow Chart</b> .....	<b>50</b>
<b>9</b>	<b>Start-up</b> .....	<b>27</b>	<b>Index</b> .....	<b>51</b>	
9.1	Carrying out the initial start-up .....	27			
9.2	Checking and treating the heating water/filling and supplementary water .....	27			

# 1 Safety

## 1.1 Intended use

The product is intended as a heat generator for open and sealed heating installations and for domestic hot water generation.

Improper use of any kind is prohibited.

Intended use also includes the following:

- use of the product only in mobile homes that are made, transported once and permanently situated in Great Britain and Ireland. After the transportation of the mobile home to its destination the complete product must be checked for leak-tightness again
- validity of the product only for Great Britain and Ireland and for the gas types in Great Britain and Ireland as listed on the data plate
- Installing and operating the product only in conjunction with accessories for the air/flue pipe which are listed in the other applicable documents and comply with the type of unit
- Using the product while observing the accompanying operating, installation and maintenance instructions for the product along with all other components of the installation
- Installing and setting up the product while observing the product and system approval
- Observing all inspection and maintenance conditions listed in the instructions
- Installing while observing the IP code

The following is classed as improper use:

- Using the product in vehicles, such as mobile homes or caravans. Units that are not classed as vehicles are those that are installed in a fixed and permanent location (known as "fixed installation").
- Any direct use in industrial or commercial processes
- Any use other than those described in these instructions and any use that goes beyond what is described here

## 1.2 Qualification

The person carrying out the work described here must have completed professional training. The competent person must demonstrably have all of the knowledge, skills and capabilities that are required in order to carry out the work mentioned below.

The following work must only be carried out by competent persons who are sufficiently qualified to do so:

- Set-up
- Dismantling
- Installation
- Start-up
- Inspection and maintenance
- Repair
- Decommissioning
- ▶ Proceed in accordance with current technology.
- ▶ Use the correct tool.

The above-mentioned work must always only be carried out by persons with sufficient qualifications.

This product can be used by children over eight years old and also by persons with limited physical, sensory or mental capabilities or insufficient experience and/or knowledge if they are supervised or have been provided with instructions on how to safely use the product, and they understand the risks resulting from using the product. Children must not play with the product. Cleaning and user maintenance work must not be carried out by children unless they are supervised.

## 1.3 General safety information

The following sections convey important safety information. It is essential to read and observe this information in order to prevent risk of death, risk of injury, material damage or environmental damage.

### 1.3.1 Gas

If you smell gas:

- ▶ Avoid rooms that smell of gas.
- ▶ If possible, open doors and windows fully and ensure adequate ventilation.
- ▶ Do not use naked flames (e.g. lighters, matches).



- ▶ Do not smoke.
- ▶ Do not use any electrical switches, mains plugs, doorbells, telephones or other communication systems in the building.
- ▶ Close the emergency control valve or the main isolator.
- ▶ If possible, close the gas stopcock on the product.
- ▶ Warn other occupants in the building by yelling or banging on doors or walls.
- ▶ Leave the building immediately and ensure that others do not enter the building.
- ▶ Notify the gas supply company or the Emergency Service Provider +44 (0) 800 111999 by telephone once you are outside of the building.

### 1.3.2 Flue gas

Flue gases may cause poisoning, while hot flue gases may also cause burns. Flue gases must therefore never be allowed to escape uncontrollably.

What to do if you smell flue gas in the property:

- ▶ Open all accessible doors and windows fully to provide ventilation.
- ▶ Switch off the product.
- ▶ Check the flue gas routes in the product and the flue gas diversions.

To prevent flue gas exit:

- ▶ Only operate the product if the air/flue pipe has been completely installed.
- ▶ With the exception of short periods for testing purposes, only operate the product when the front casing is installed and closed.
- ▶ If you operate the product with an empty condensate trap / siphon, then flue gas may escape into the room air.
- ▶ In order to operate the product, ensure that the condensate trap / siphon is always full.

To ensure that the seals are not damaged:

- ▶ Instead of grease, use only water or commercially available soft soap to aid installation.

### 1.3.3 Electricity

The power supply terminals L and N remain live even if the unit main switch is switched off.

To prevent electric shocks, proceed as follows before working on the product:

- ▶ Disconnect the product from the power supply by switching off all power supplies at all poles (electrical partition with a contact gap of at least 3 mm, e.g. fuse or circuit breaker) or remove the mains plug (if present).
- ▶ Secure against being switched back on again.
- ▶ Wait at least three minutes until the condensers have discharged.
- ▶ Check that there is no voltage.

### 1.3.4 Weight

To prevent injuries when transporting the product:

- ▶ Make sure that the product is transported by at least two people.

### 1.3.5 Explosive and flammable substances

To prevent explosions and fire:

- ▶ Do not use the product in storage rooms that contain explosive or flammable substances (such as petrol, paper or paint).

### 1.3.6 High temperatures

To prevent burns:

- ▶ Only carry out work on components once they have cooled down.

To prevent material damage that is caused by heat transfer:

- ▶ Only solder connectors if the connectors are not yet screwed to the service valves.

### 1.3.7 Heating water

Both unsuitable heating water and air in the heating water may cause material damage to the product and in the heat generator circuit.

- ▶ Check the quality of the heating water. (→ Page 27)
- ▶ If you use non-diffusion-tight plastic pipes in the heating installation, ensure that no air gets into the heat generator circuit.

### 1.3.8 Neutralisation device

To prevent contamination of the waste water:

- ▶ Check whether a neutralising unit must be installed in accordance with national regulations.



- 
- ▶ Observe local regulations on neutralising condensate.

### **1.3.9 Frost**

To prevent material damage:

- ▶ Do not install the product in rooms prone to frost.

### **1.3.10 Safety devices**

- ▶ Install the necessary safety devices in the installation.

## **1.4 Regulations (directives, laws, standards)**

- ▶ Observe the national regulations, standards, directives, ordinances and laws.

## **1.5 List of relevant standards for Great Britain and Ireland**

- ▶ Observe the national regulations, standards, directives, ordinances and laws.



You can find a list of relevant standards at:  
<https://www.vaillant.co.uk/standards>



## Guarantee Registration

Thank you for installing a new Vaillant appliance in your home.

Vaillant appliances are manufactured to the very highest standard so we are pleased to offer our customers a comprehensive guarantee.

To maintain your guarantee, the boiler must be serviced annually by a competent person who holds the required qualifications in accordance with the rules in force of the country where the product is installed and in accordance with the manufacturer's recommendations.

We recommend you complete your guarantee registration as soon as possible.

### **Sales Support:**

Telephone: 0345 602 0262

### **Technical Enquiries:**

Telephone: 0344 693 3133

Email: [technical@vaillant.co.uk](mailto:technical@vaillant.co.uk)

### **General Enquiries:**

Telephone: 0345 602 2922

### **Training Enquiries:**

Telephone: 0345 601 8885

Email: [training.enquiriesuk@vaillant-group.com](mailto:training.enquiriesuk@vaillant-group.com)

### **Spares Enquiries:**

Telephone: 01773 596 615

### **To register your Vaillant appliance visit:**

<https://self-service.vaillant.co.uk/warranty-registration>



Vaillant is a licensed member of the Benchmark Scheme. Benchmark places responsibilities on both manufacturers and installers. The purpose is to ensure that customers are provided with the correct equipment for their needs, that it is installed, commissioned and serviced in accordance with the manufacturer's instructions by a competent person approved at the time by the Health and Safety Executive and that it meets the requirements of the appropriate Building Regulations. The Benchmark Checklist can be used to demonstrate compliance with Building Regulations and should be provided to the customer for future reference.

Installers are required to carry out installation, commissioning and servicing work in accordance with the Benchmark Code of Practice which is available from the Heating and Hotwater Industry Council who manage and promote the Scheme. Benchmark is managed and promoted by the Heating and Hotwater Industry Council.



### 3 Technical data

#### Technical data – General

	VU 126/6-3 OV (H-GB)	VU 156/6-3 OV (H-GB)	VU 186/6-3 OV (H-GB)
Gas category	I <sub>2H</sub>	I <sub>2H</sub>	I <sub>2H</sub>
Diameter of the gas pipe	1/2 inch	1/2 inch	1/2 inch
Diameter of the heating connections	3/4 inch	3/4 inch	3/4 inch
Expansion relief valve connection pipe (min.)	15 mm	15 mm	15 mm
Condensate discharge pipe (min.)	21.5 mm	21.5 mm	21.5 mm
G20 gas supply pressure	2.0 kPa (20.0 mbar)	2.0 kPa (20.0 mbar)	2.0 kPa (20.0 mbar)
Gas flow at P max. – hot water (G20)	1.6 m <sup>3</sup> /h	1.9 m <sup>3</sup> /h	2.7 m <sup>3</sup> /h
Gas flow at P max. – heating mode (G20)	1.3 m <sup>3</sup> /h	1.6 m <sup>3</sup> /h	1.9 m <sup>3</sup> /h
Gas flow at P min. (G20)	0.480 m <sup>3</sup> /h	0.480 m <sup>3</sup> /h	0.533 m <sup>3</sup> /h
CE number (PIN)	CE-0063CP3646	CE-0063CP3646	CE-0063CP3646
SAP 2009/2012 annual efficiency (%)	89.8	89.8	89.7
Flue gas mass rate in heating mode at P min.	2.08 g/s	2.08 g/s	2.31 g/s
Flue gas mass rate in heating mode at P max.	5.5 g/s	6.9 g/s	8.3 g/s
Flue gas mass rate in hot water handling mode at P max.	6.9 g/s	8.3 g/s	11.6 g/s
Flue gas temperature (80 °C/60 °C) at P max.	55 °C	55 °C	60 °C
Flue gas temperature (80 °C/60 °C) at P min.	55 °C	55 °C	55 °C
Flue gas temperature (50 °C/30 °C) at P max.	43 °C	48 °C	51 °C
Flue gas temperature (50 °C/30 °C) at P min.	32 °C	32 °C	34 °C
Flue gas temperature in hot water handling mode	71 °C	71 °C	69 °C
Flue gas temperature when overheating	105 °C	105 °C	105 °C
Released system types	C13, C33, C43, C53	C13, C33, C43, C53	C13, C33, C43, C53
Nominal efficiency at 80/60 °C	99.1 %	98.9 %	98.8 %
Nominal efficiency at 50/30 °C	104.0 %	104.0 %	104.0 %
Nominal efficiency at 40/30 °C	106.0 %	106.0 %	106.0 %
Nominal efficiency in partial load operation (30%) at 40/30 °C	109.9 %	109.9 %	109.8 %
NOx class	6	6	6
Product dimensions, width	375 mm	375 mm	375 mm
Product dimensions, depth	295 mm	295 mm	295 mm
Product dimensions, height	602 mm	602 mm	602 mm
Net weight	22 kg	22 kg	22 kg
Weight when filled with water	26 kg	26 kg	26 kg

	VU 256/6-3 OV (H-GB)	VU 306/6-3 OV (H-GB)	VU 356/6-3 OV (H-GB)
Gas category	I <sub>2H</sub>	I <sub>2H</sub>	I <sub>2H</sub>
Diameter of the gas pipe	1/2 inch	1/2 inch	1/2 inch
Diameter of the heating connections	3/4 inch	3/4 inch	3/4 inch
Expansion relief valve connection pipe (min.)	15 mm	15 mm	15 mm
Condensate discharge pipe (min.)	21.5 mm	21.5 mm	21.5 mm
G20 gas supply pressure	2.0 kPa (20.0 mbar)	2.0 kPa (20.0 mbar)	2.0 kPa (20.0 mbar)
Gas flow at P max. – hot water (G20)	3.2 m <sup>3</sup> /h	3.8 m <sup>3</sup> /h	3.8 m <sup>3</sup> /h
Gas flow at P max. – heating mode (G20)	2.7 m <sup>3</sup> /h	3.2 m <sup>3</sup> /h	3.8 m <sup>3</sup> /h
Gas flow at P min. (G20)	0.648 m <sup>3</sup> /h	0.756 m <sup>3</sup> /h	0.762 m <sup>3</sup> /h
CE number (PIN)	CE-0063CP3646	CE-0063CP3646	CE-0063CP3646
SAP 2009/2012 annual efficiency (%)	89.7	89.8	–
Flue gas mass rate in heating mode at P min.	2.81 g/s	3.27 g/s	3.30 g/s
Flue gas mass rate in heating mode at P max.	11.5 g/s	13.8 g/s	16.1 g/s
Flue gas mass rate in hot water handling mode at P max.	13.8 g/s	16.1 g/s	16.1 g/s
Flue gas temperature (80 °C/60 °C) at P max.	77 °C	86 °C	90 °C
Flue gas temperature (80 °C/60 °C) at P min.	55 °C	56 °C	56 °C
Flue gas temperature (50 °C/30 °C) at P max.	62 °C	60 °C	62 °C
Flue gas temperature (50 °C/30 °C) at P min.	35 °C	37 °C	37 °C
Flue gas temperature in hot water handling mode	68 °C	75 °C	75 °C
Flue gas temperature when overheating	95 °C	104 °C	104 °C
Released system types	C13, C33, C43, C53	C13, C33, C43, C53	C13, C33, C43, C53
Nominal efficiency at 80/60 °C	98.8 %	99.2 %	97.5 %
Nominal efficiency at 50/30 °C	104.0 %	104.0 %	100.2 %
Nominal efficiency at 40/30 °C	106.0 %	106.0 %	106.0 %
Nominal efficiency in partial load operation (30%) at 40/30 °C	109.7 %	109.8 %	108.5 %
NOx class	6	6	6
Product dimensions, width	375 mm	375 mm	375 mm
Product dimensions, depth	295 mm	295 mm	295 mm
Product dimensions, height	602 mm	602 mm	602 mm
Net weight	22 kg	22 kg	23 kg
Weight when filled with water	26 kg	27 kg	28 kg

#### Technical data – G20 power/load G20

	VU 126/6-3 OV (H-GB)	VU 156/6-3 OV (H-GB)	VU 186/6-3 OV (H-GB)
Maximum heat output	12 kW	15 kW	18 kW
Effective output range (P) at 40/30 °C	4.8 to 13.0 kW	4.8 to 16.2 kW	5.3 to 19.5 kW

	VU 126/6-3 OV (H-GB)	VU 156/6-3 OV (H-GB)	VU 186/6-3 OV (H-GB)
Effective output range (P) at 50/30 °C	4.7 to 12.8 kW	4.7 to 15.9 kW	5.2 to 19.1 kW
Effective output range (P) at 80/60 °C	4.5 to 12.2 kW	4.5 to 15.2 kW	5.0 to 18.3 kW
Domestic hot water heat output (P)	4.4 to 15.0 kW	4.4 to 18.0 kW	4.9 to 25.2 kW
Maximum heat input – heating (Q max.)	12.3 kW	15.3 kW	18.4 kW
Minimum heat input – heating (Q min.)	4.5 kW	4.5 kW	5.0 kW
Maximum heat input – hot water (Q max.)	15.3 kW	18.4 kW	25.7 kW
Minimum heat input – hot water (Q min.)	4.5 kW	4.5 kW	5.0 kW

	VU 256/6-3 OV (H-GB)	VU 306/6-3 OV (H-GB)	VU 356/6-3 OV (H-GB)
Maximum heat output	25 kW	30 kW	35 kW
Effective output range (P) at 40/30 °C	6.5 to 27.0 kW	7.6 to 32.4 kW	7.6 to 37.8 kW
Effective output range (P) at 50/30 °C	6.4 to 26.5 kW	7.4 to 31.8 kW	7.0 to 35.8 kW
Effective output range (P) at 80/60 °C	6.1 to 25.4 kW	7.1 to 30.2 kW	7.2 to 34.8 kW
Domestic hot water heat output (P)	6.0 to 30.0 kW	7.0 to 35.0 kW	7.1 to 35.0 kW
Maximum heat input – heating (Q max.)	25.6 kW	30.6 kW	35.7 kW
Minimum heat input – heating (Q min.)	6.1 kW	7.1 kW	7.2 kW
Maximum heat input – hot water (Q max.)	30.6 kW	35.7 kW	35.7 kW
Minimum heat input – hot water (Q min.)	6.1 kW	7.1 kW	7.2 kW

### Technical data – Heating

	VU 126/6-3 OV (H-GB)	VU 156/6-3 OV (H-GB)	VU 186/6-3 OV (H-GB)
Max. flow temperature adjustment range (default setting: 75 °C)	10 to 80 °C	10 to 80 °C	10 to 80 °C
Maximum permissible pressure	0.25 MPa (2.50 bar)	0.25 MPa (2.50 bar)	0.25 MPa (2.50 bar)
Nominal water flow (ΔT = 20 K)	530 l/h	655 l/h	788 l/h
Nominal water flow (ΔT = 30 K)	353 l/h	436 l/h	525 l/h
Approximate value for the condensate volume (pH value between 3.5 and 4.0) at 50/30 °C	1.23 l/h	1.53 l/h	1.84 l/h

	VU 256/6-3 OV (H-GB)	VU 306/6-3 OV (H-GB)	VU 356/6-3 OV (H-GB)
Max. flow temperature adjustment range (default setting: 75 °C)	10 to 80 °C	10 to 80 °C	10 to 80 °C
Maximum permissible pressure	0.25 MPa (2.50 bar)	0.25 MPa (2.50 bar)	0.25 MPa (2.50 bar)
Nominal water flow (ΔT = 20 K)	1,094 l/h	1,313 l/h	1,535 l/h

	VU 256/6-3 OV (H-GB)	VU 306/6-3 OV (H-GB)	VU 356/6-3 OV (H-GB)
Nominal water flow ( $\Delta T = 30 \text{ K}$ )	729 l/h	876 l/h	1,023 l/h
Approximate value for the condensate volume (pH value between 3.5 and 4.0) at 50/30 °C	2.55 l/h	3.06 l/h	3.65 l/h

#### Technical data – Electrics

	VU 126/6-3 OV (H-GB)	VU 156/6-3 OV (H-GB)	VU 186/6-3 OV (H-GB)
Electrical connection	230 V / 50 Hz	230 V / 50 Hz	230 V / 50 Hz
Built-in fuse (slow-blow)	T2/2A, 250V	T2/2A, 250V	T2/2A, 250V
Max. electrical power consumption	23 W	29 W	35 W
Standby electrical power consumption	2 W	2 W	2 W
IP rating	IPX4D	IPX4D	IPX4D

	VU 256/6-3 OV (H-GB)	VU 306/6-3 OV (H-GB)	VU 356/6-3 OV (H-GB)
Electrical connection	230 V / 50 Hz	230 V / 50 Hz	230 V / 50 Hz
Built-in fuse (slow-blow)	T2/2A, 250V	T2/2A, 250V	T2/2A, 250V
Max. electrical power consumption	35 W	44 W	50 W
Standby electrical power consumption	2 W	2 W	2 W
IP rating	IPX4D	IPX4D	IPX4D

## 4 Notes on the documentation

- ▶ Always observe all operating instructions enclosed with the installation components.
- ▶ Store these instructions and all other applicable documents for further use.

These instructions apply only to:

### Product article number

	Article number	Gas Council Number
VU 126/6-3 OV (H-GB) ecoFIT pure 412	0010020400	41-694-08
VU 156/6-3 OV (H-GB) ecoFIT pure 415	0010020401	41-694-09
VU 186/6-3 OV (H-GB) ecoFIT pure 418	0010020402	41-694-10
VU 256/6-3 OV (H-GB) ecoFIT pure 425	0010020403	41-694-11
VU 306/6-3 OV (H-GB) ecoFIT pure 430	0010020404	41-694-12
VU 356/6-3 OV (H-GB) ecoFIT pure 435	0010020405	41-694-19

## 5 Product description

### 5.1 CE marking



The CE marking shows that the products comply with the basic requirements of the applicable directives as stated on the declaration of conformity.

The declaration of conformity can be viewed at the manufacturer's site.

### 5.2 Hot Water Association

Vaillant is a full member of the Hot Water Association and promotes the scheme in association with its cylinder range. Details are available on the web site [www.vaillant.co.uk](http://www.vaillant.co.uk)



### 5.3 Information on the data plate

The data plate is mounted on the underside of the product at the factory.

The data plate keeps record of the country in which the product is to be installed.

Information on the identification plate	Meaning
	Barcode with serial number

Information on the identification plate	Meaning
Serial number	For quality control purposes; 3rd and 4th digits = year of production For quality control purposes; 5th and 6th digits = week of production For identification purposes; 7th to 16th digits = product article number For quality control purposes; 17th to 20th digits = place of manufacture
ecoFIT pure	Product designation
2H, G20 – 2 kPa (20 mbar)	Factory setting for type of gas and gas connection pressure
Cat.	Unit category
Condensing technology	Efficiency class of the boiler in accordance with EC Directive 92/42/EEC
Type: Xx3(x)	Permissible flue gas connections
PMS	Maximum water pressure in heating mode
PMW	Maximum water pressure in hot water handling mode
V/Hz	Electrical connection
W	Max. electrical power consumption
IP	Level of protection
	Heating mode
P <sub>n</sub>	Nominal heat output range in heating mode
P <sub>nc</sub>	Nominal heat output range in heating mode (condensing technology)
P	Nominal heat output range in hot water handling mode
Q <sub>n</sub>	Nominal heating load range in heating mode
Q <sub>nw</sub>	Nominal heating load range in hot water handling mode
T <sub>max.</sub>	Max. flow temperature
NOx	NOx class for the product
Code (DSN)	Specific product code
	Read the instructions.
GC no.	Gas council number

## 5.4 Functional elements

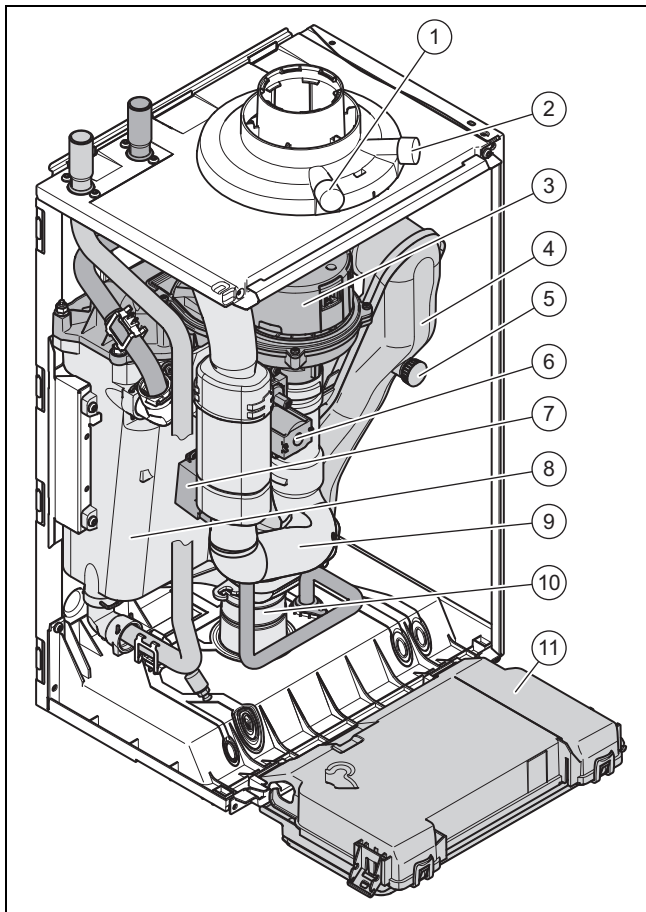

- |   |   |    |  |
|---|---|----|--|
| 1 | Supply air test point<br>(for the upper air/flue<br>connection)   | 5  | Flue gas analysis point<br>(for the rear air/flue<br>connection) |
| 2 | Flue gas analysis point<br>(for the upper air/flue<br>connection) | 6  | Gas valve assembly   |
| 3 | Fan/gas-air mixture   | 7  | Ignition transformer   |
| 4 | Flue pipe   | 8  | Heat exchanger   |
|   |   | 9  | Air intake pipe  |
|   |   | 10 | Condensate trap  |
|   |   | 11 | Electronics box  |

## 5.5 Safety Devices

### 5.5.1 Electrical Supply Failure

The boiler will not work without an electrical supply. Normal operation of the boiler should resume when the electrical supply is restored.

Reset any external controls, to resume normal operation of the central heating.

If the boiler does not resume normal operation press the reset button. If the boiler does not resume normal operation after this call your Installation/ Servicing company or Vaillant service.

### 5.5.2 Overheating Safety

The boiler software is designed to recognise the potential for an overheat lockout and will shutdown before this happens. To restart the boiler, press the reset button on the boiler interface.

If the boiler fails to resume normal operation and all external controls are calling for heat, then call your Installation/ Servicing company or Vaillant service.

### 5.5.3 Frost protection

The appliance has a built in frost protection device that protects the boiler from freezing. With the gas and electric supplies ON and irrespective of any room thermostat setting, the frost protection device will operate the pump when the temperature of the boiler water falls below 12 °C.

A timer is used so that the temperature can be checked periodically. After 10 minutes the pump will be stopped if the temperature is higher than 10 °C or has already reached 35 °C. The burner will activate if the boiler temperature does not reach 10 °C after 30 minutes or at any time if the temperature drops to 5 °C.

The burner will switch off when the temperature reaches 35 °C.

### 5.5.4 Condensate Drain Blockage

As a safety feature the boiler will stop working if the condensate drain becomes blocked. During freezing conditions this may be due to the forming of ice in the condensate drain external to the house. Release an ice blockage by the use of warm cloths on the pipe. After pressing reset the boiler should restart.

## 6 Set-up

### 6.1 Checking the scope of delivery

- ▶ Check that the scope of delivery is complete and intact.

#### 6.1.1 Scope of delivery

Number	Designation
1	Heat generator
1	Unit mounting bracket
1	Flue adapter
1	Gas stopcock
1	Gas pipe
1	Condensate discharge hose
1	Mounting template
1	Enclosed documentation

## 6.2 Dimensions

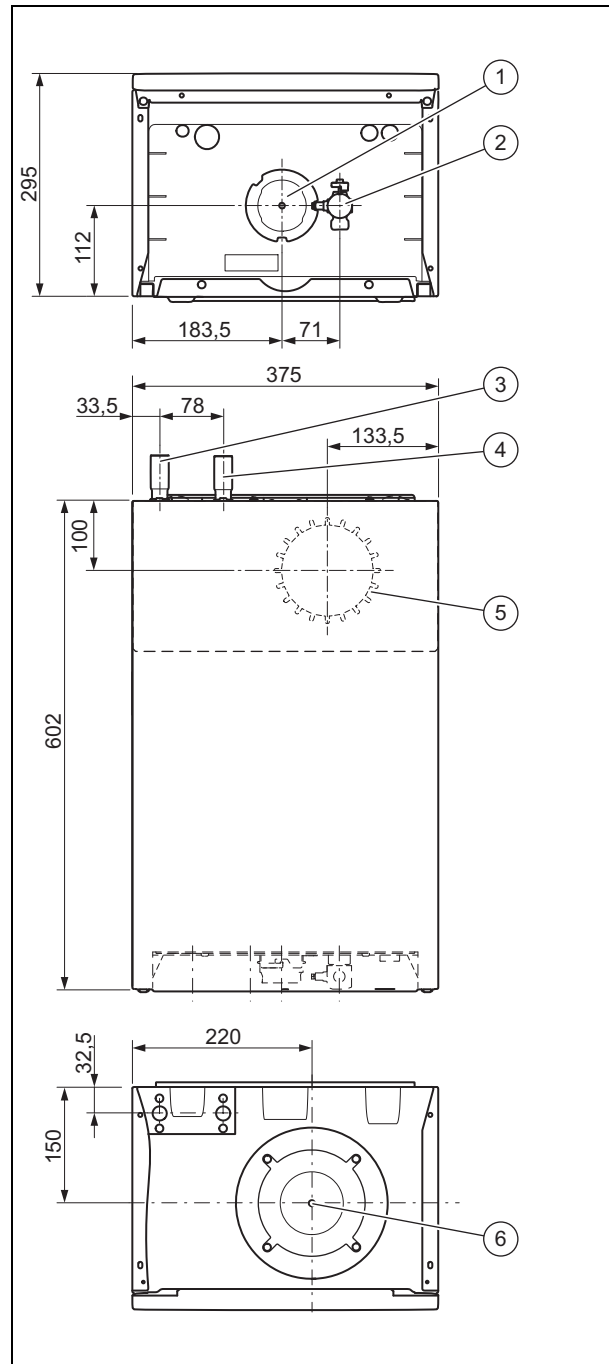

- |   |                      |   |                          |
|---|----------------------|---|--------------------------|
| 1 | Condensate discharge | 4 | Heating flow             |
| 2 | Gas connection       | 5 | Rear air/flue connection |
| 3 | Heating return       | 6 | Top air/flue connection  |

### 6.3 Installation site

This boiler is not suitable for outdoor installation. This boiler may be installed in any room. However if the boiler is being installed in a room containing a bath or shower it must only be installed in zones 2 or 3. In GB this is the current I.E.E. WIRING REGULATIONS and BUILDING REGULATIONS. In IE reference should be made to the current edition of I.S.813 "Domestic Gas Installations" and the current ETCI rules.

If the boiler is to be installed in a timber frame building it should be fitted in accordance with the current version of the Institute of Gas Engineers document IGE/UP/7. If in doubt seek advice from local gas undertaking or the manufacturer.

## 6.4 Minimum clearances

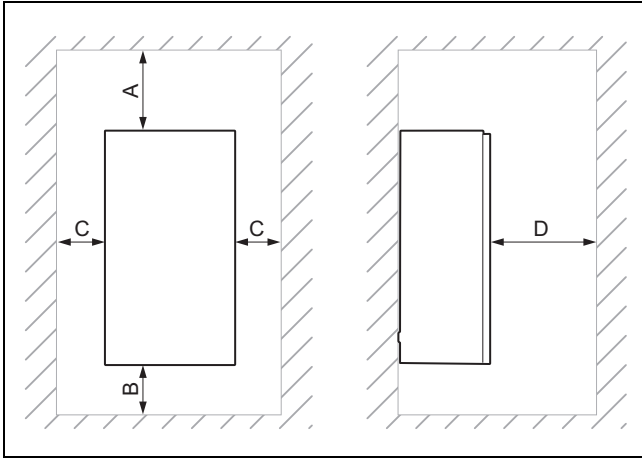

	Minimum clearance
A	150 mm (top air/flue connection) 75 mm (rear air/flue connection)
B	150 mm
C	5 mm (70 mm, if the side sections have to be removed)
D	500 mm

The boiler and flue are suitable for installation onto and through combustible materials provided that:

1. Minimum 5 mm clearance is maintained around the circumference of the flue (air intake).
2. The combustible surface and fixings are suitable for supporting the load.
3. The minimum clearances from the boiler case are maintained.

### 6.4.1 Compartment Ventilation

The boilers are very high efficiency appliances.

As a consequence the heat loss from the appliance casing during operation is very low.

Compartment ventilation is not required as the products are only certified, and can only be fitted with a concentric flue system.

## 6.5 Air/flue pipe

### 6.5.1 Regulation

Different flue outlet configurations can be carried out.

- Consult the installation manual for air/flue gas systems for more information about the other possibilities and associated accessories.

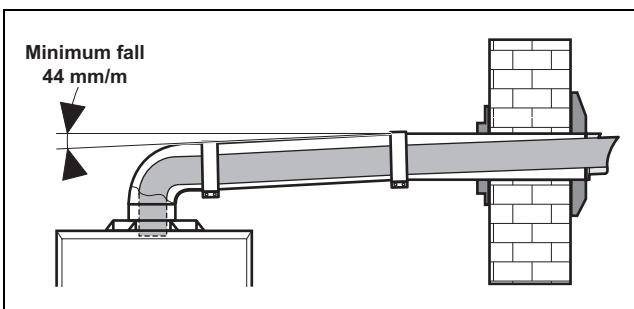

- Standard flue terminal kits have an in-built fall back to the boiler to drain the condensate. These can be fitted

level between the appliance and the termination position. All other extended flues must have a fall of at least 44 mm/m.

The maximum length of the flue outlet is defined according to its type (for example C13).

- Whatever the kind of flue system chosen, observe the minimum distances to position the flue terminals.
- To install the flue, refer to the separate flue instruction supplied with your appliance.
- Explain these requirements to the user of the appliance.

In GB the minimum acceptable siting dimensions for the terminal from obstructions, other terminals and ventilation openings are shown in diagram overleaf.

In IE the minimum distances for flue terminal positioning must be those detailed in I.S. 813 "Domestic Gas Installations".

The terminal must be exposed to the external air, allowing free passage of air across it at all times.

Being a condensing boiler some plumbing may occur from the flue outlet. This should be taken into consideration when selecting the position for the terminal.

## 6.5.2 Position of the air/flue terminal

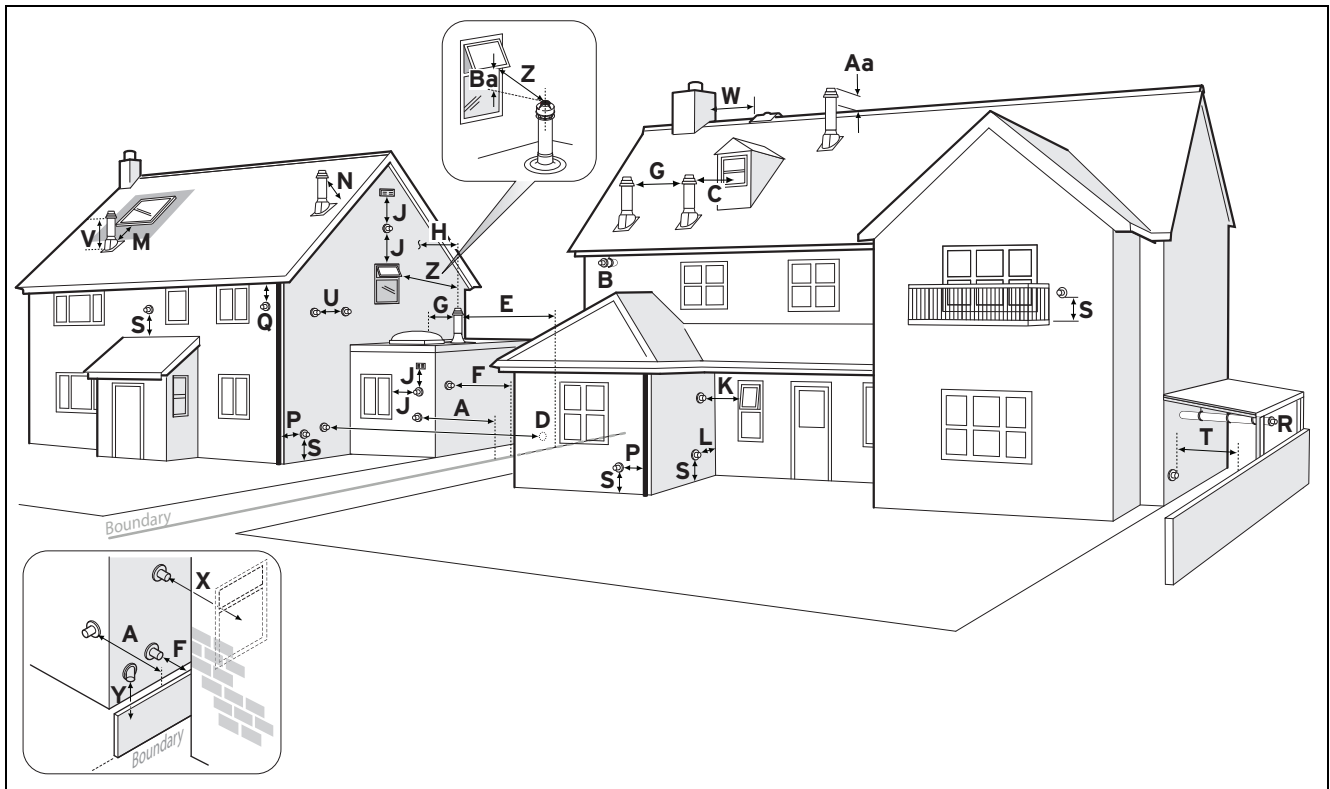

### 6.5.2.1 Positioning the terminal of a fan-supported flue system

	Installation site	Dimensions
A	Adjacent to a boundary.	300 mm
B <sup>1)</sup>	The dimension below eaves, balconies and car ports can be reduced to this value, as long as the flue terminal is extended to clear any overhang. External flue joints must be sealed with a suitable silicon sealant.	25 mm
C	Between a vertical flue terminal and a window or dormer window on a roof.	1,500 mm
D	Between terminals facing each other.	1,200 mm
E	Vertical flue clearance, adjacent to a boundary line.	300 mm
F <sup>2)</sup>	Distance to a boundary line, unless it will cause a nuisance. BS 5440:Part 1 recommends that care is taken when siting terminal in relation to boundary lines.	600 mm
G	Minimum clearance from a skylight to a vertical flue or to another vertical flue.	Min. 300 mm
H	Vertical flue clearance, to noncombustible building material. Vertical flue clearance to combustible building material.	500 mm 1,500 mm
J	Above, below and either side of an opening door, air vent or opening window.	300 mm
K	Diagonally to an opening door, air vent or opening window.	600 mm
L <sup>2)</sup>	To an internal or external corner.	200 mm
M	Below a Velux window. Above or to either side of the Velux window.	2,000 mm 600 mm
N	From a pitched roof. In regions with heavy snowfall.	400 mm 500 mm
P	From vertical drain pipes and soil pipes.	25 mm
Q	Below eaves. Below gutters, pipe and drains.	200 mm 75 mm
	<p>1) There should be no ventilation/opening in the eaves within 300 mm distance of the terminal.</p> <p>2) These dimensions comply with the building regulations, but they may need to be increased to avoid wall staining and nuisance from pluming depending on site conditions.</p> <ul style="list-style-type: none"> <li>- Terminals must be positioned so to avoid combustion products entering the building.</li> <li>- Support the flue at approximately one metre intervals and at a change of direction, use suitable brackets and fixings.</li> <li>- Installations in car ports are not recommended.</li> <li>- The flue cannot be lower than 1 metre from the top of a lightwell due to the build up of combustion products.</li> <li>- Dimensions from a flue terminal to a fanned air inlet to be determined by the ventilation equipment.</li> </ul>	

	Installation site	Dimensions
R	The dimension below eaves, balconies and car ports can be reduced to this value, as long as the flue terminal is extended to clear any overhang. External flue joints must be sealed with suitable silicon sealant.	25 mm
S	Above adjacent ground or balcony.	300 mm
T <sup>2)</sup>	Distance to a surface facing a terminal, unless it will cause a nuisance. BS 5440: Part 1 recommends that care is taken when siting terminals in relation to surfaces facing a terminal.	600 mm
U	Clearance alongside another terminal.	300 mm
V	Above roof level.	300 mm
W	Minimum to vertical structure on roof, roof vent.	Min. 300 mm
X	Minimum to opening in adjacent building.	Min. 2000 mm
Y	Minimum at an angle to a boundary which is not less than 300 mm to the terminal	Min. 600 mm
Z	Minimum measured to the nearest corner of the OPEN window	Min. 600 mm
Aa	No more than this value above ridge.	Max. 300 mm
Ba	Not less than this value below the opening window	Min. 300 mm
	1) There should be no ventilation/opening in the eaves within 300 mm distance of the terminal. 2) These dimensions comply with the building regulations, but they may need to be increased to avoid wall staining and nuisance from pluming depending on site conditions. <ul style="list-style-type: none"> <li>– Terminals must be positioned so to avoid combustion products entering the building.</li> <li>– Support the flue at approximately one metre intervals and at a change of direction, use suitable brackets and fixings.</li> <li>– Installations in car ports are not recommended.</li> <li>– The flue cannot be lower than 1 metre from the top of a lightwell due to the build up of combustion products.</li> <li>– Dimensions from a flue terminal to a fanned air inlet to be determined by the ventilation equipment.</li> </ul>	

### 6.5.2.2 Horizontal terminal positioning

BS 5440-1 recommends that fanned flue chimney terminals should be positioned as follows:

- a) at least 2 m from an opening in the building directly opposite, and
- b) so that the products of combustion are not directed to discharge directly across a boundary if the products are likely to cause a nuisance to a neighbour or discharge over a walkway or patio.

For IE see current issue of IS 813.

For boilers covered within this manual.

Dimensions B and R:

These clearances may be reduced to 25 mm without affecting the performance of the boiler. In order to ensure that the condensate plume does not affect adjacent surfaces the terminal should be extended as shown below.

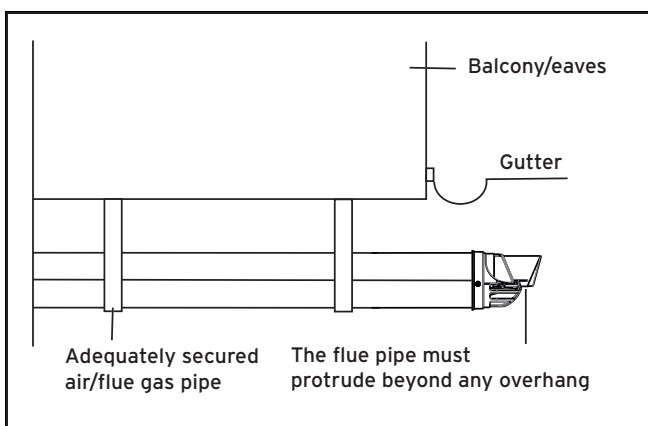

You can use a plume management kit to enable the termination point to be positioned and directed away from the building fabric.

## 6.5.3 Flue Configuration Description

### 6.5.3.1 Horizontal Concentric Flue $\varnothing$ 60/100 mm or $\varnothing$ 80/125 mm (C13 type installation)

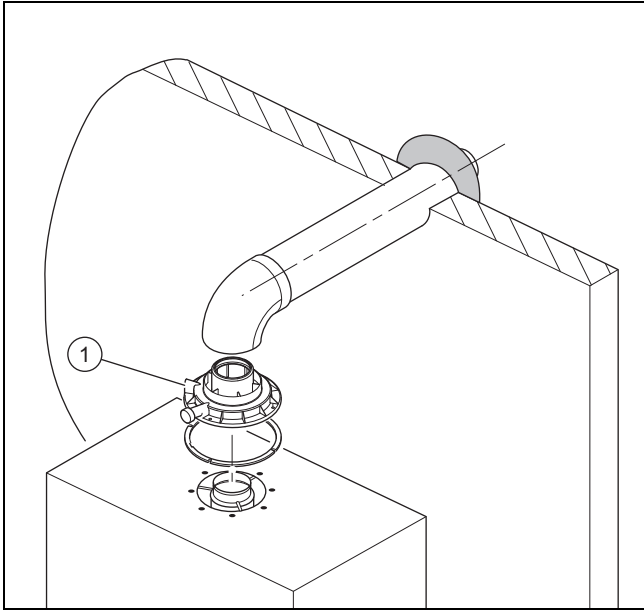

1 Gasket (fitted)



#### Note

If the terminal is at less than 1.80 m from the ground, you must install a terminal protection kit.

Consult the separate installation manual for air/flue gas systems supplied with your appliance for all possibilities and associated accessories and how to install the flue system.

### 6.5.3.2 Terminal protection

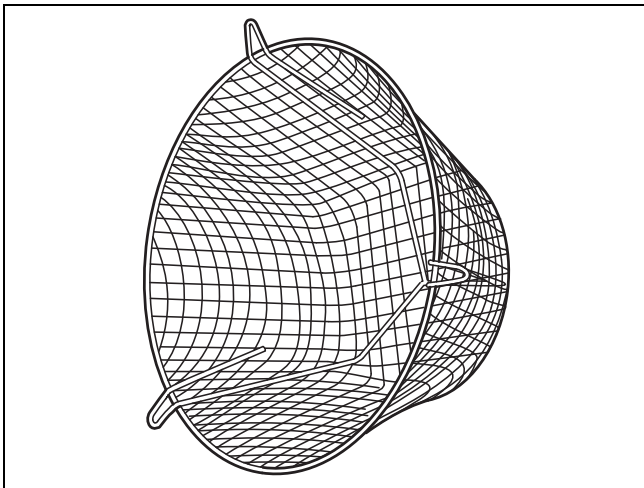

A terminal guard is required if persons could come into contact with the terminal or the terminal could be subject to damage.

If a terminal guard is required, it must be positioned to provide minimum of 50 mm clearance from any part of the terminal and be central over the terminal.

The guard should be similar to that shown in the figure.

### 6.5.3.3 Vertical Concentric Flue $\varnothing$ 60/100 mm or $\varnothing$ 80/125 mm (C33 type installation)

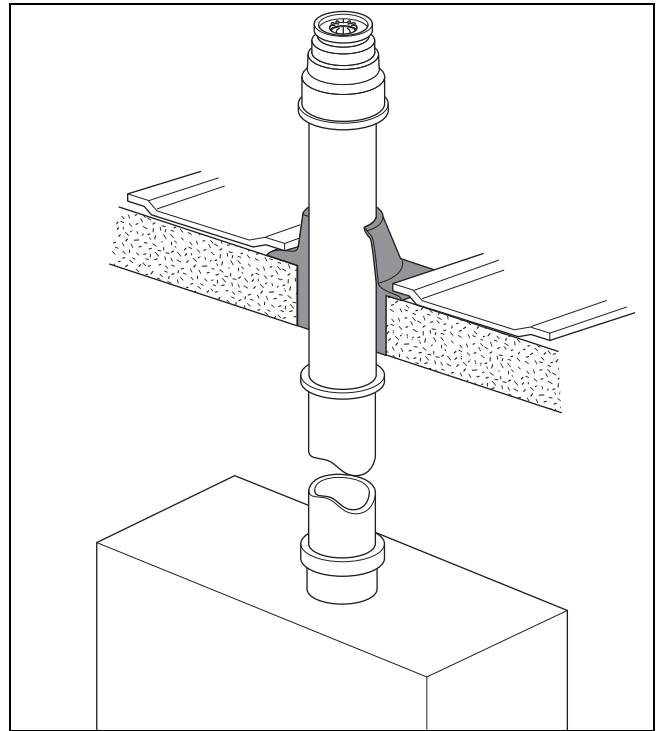

Consult the separate installation manual for air/flue gas systems supplied with your appliance for all possibilities and associated accessories and how to install the flue system.

## 6.6 Using the mounting template

- ▶ Use the mounting template to ascertain the locations at which you need to drill holes.

## 6.7 Wall-mounting the product



#### Note

If you are using the rear air/flue connection, install the air/flue pipe before you wall-mount the product.

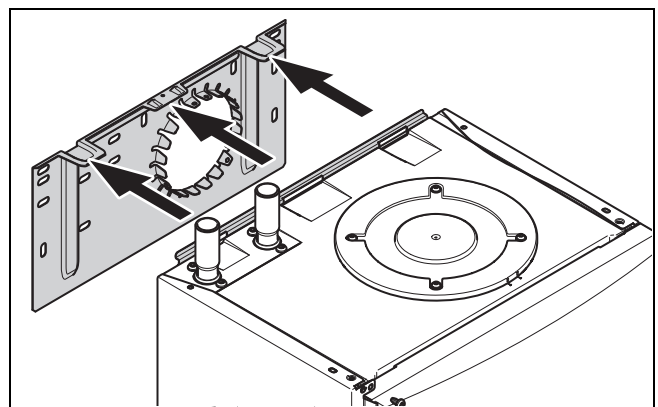

1. Check the load-bearing capacity of the wall.
2. Note the total weight of the product.
3. Only use fixing material that is permitted for the wall.
4. If required, ensure that mounting apparatus on-site has sufficient load-bearing capacity.
5. Wall-mount the product as described.

## 6.8 Removing/installing the front casing

### 6.8.1 Removing the front casing

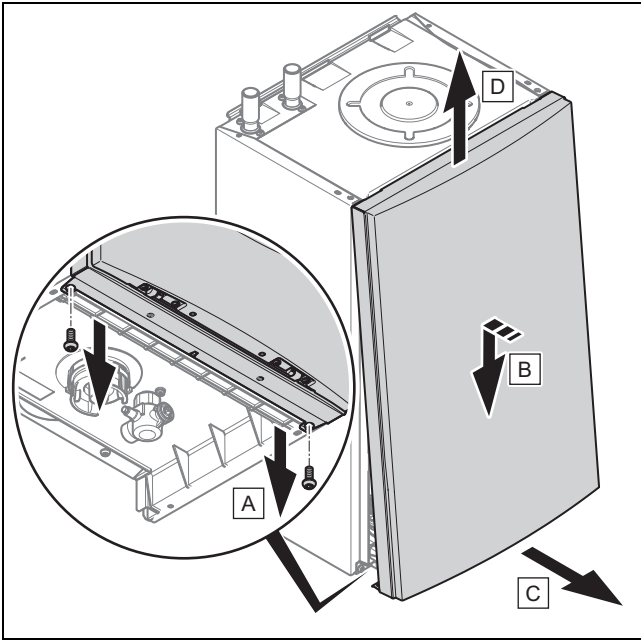

### 6.8.2 Installing the front casing

- ▶ Refit the components in the reverse order.

## 6.9 Removing/installing the side section

### 6.9.1 Removing the side section



#### Caution.

**Risk of material damage caused by mechanical deformation.**

Removing **both** side sections may cause mechanical distortion in the product, which may cause damage to the piping, for example, and potentially result in leaks.

- ▶ Always only remove **one** side section – never both side sections at the same time.



#### Note

If there is sufficient lateral clearance (at least 70 mm), you can remove the side section to facilitate maintenance or repair work.

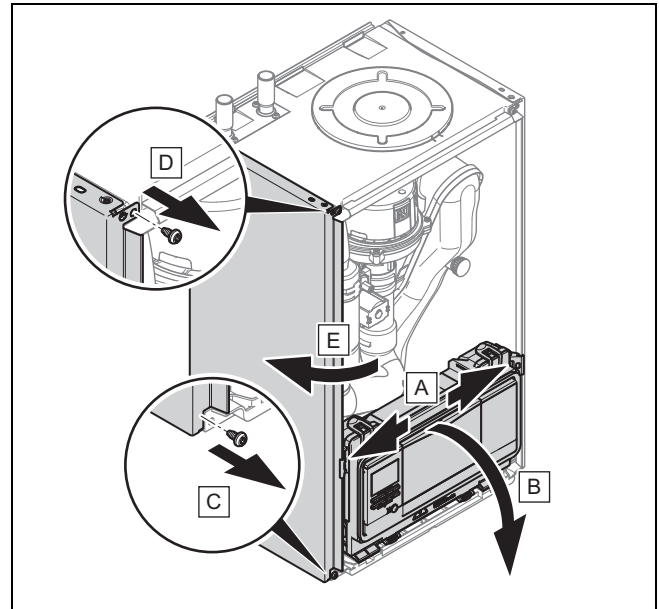

### 6.9.2 Installing the side section

- ▶ Refit the components in the reverse order.

## 7 Installation

### 7.1 Preparing for installation

- ▶ Make sure that the existing gas meter and the pipelines are capable of passing the rate of gas supply required.
- ▶ Consider the maximum heat output given in DHW mode.
- ▶ Install the following components:
  - Draining cocks at the lowest points in the heating installation (→ current version of "BS 2879")
  - A bypass that is at least 1.5 m away from the product
  - A stopcock in the gas pipe
  - Where applicable, a flow regulator valve to adjust the flow rate
- ▶ Install the connection pipes such that they are free from mechanical stress.
- ▶ If you use non-diffusion-tight plastic pipes in the heating installation, ensure that no air gets into the heat generator circuit.
- ▶ Only solder connectors if the connectors are not yet screwed to the service valves.
- ▶ Only bend connection pipes if they have not yet been connected to the product.
- ▶ Flush the heating installation thoroughly before installing the product.
- ▶ Check the leak-tightness of the gas valve assembly using a pressure of  $\leq 11$  kPa (110 mbar).

### 7.2 Installing the heating pump

#### Pressure loss from the product

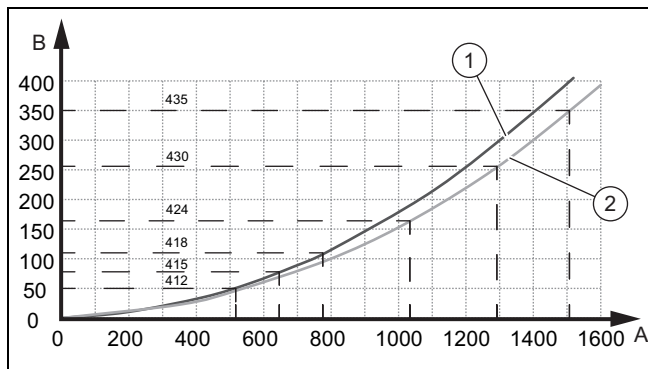

A	Flow rate [l/h]	1	Pressure loss – ecoFIT pure 412 - 418
B	Pressure loss [mbar]	2	Pressure loss – ecoFIT pure 424 - 435

The flow rate must not fall below the value in the diagram.

- ▶ Only use pumps that have an in-rush current  $\leq 10/15$  A.
- ▶ When designing/selecting the pump, note the pressure loss of the product.
- ▶ Install the pump in the heating flow.
- ▶ Install isolation valves upstream and downstream of the pump.
- ▶ Set the pump so that the temperature difference between the flow and return is no more than 20 °C when the maximum flow temperature is set.

- The flow rate specified in the technical data is reached.

### 7.3 Heating water supply in the open heating system

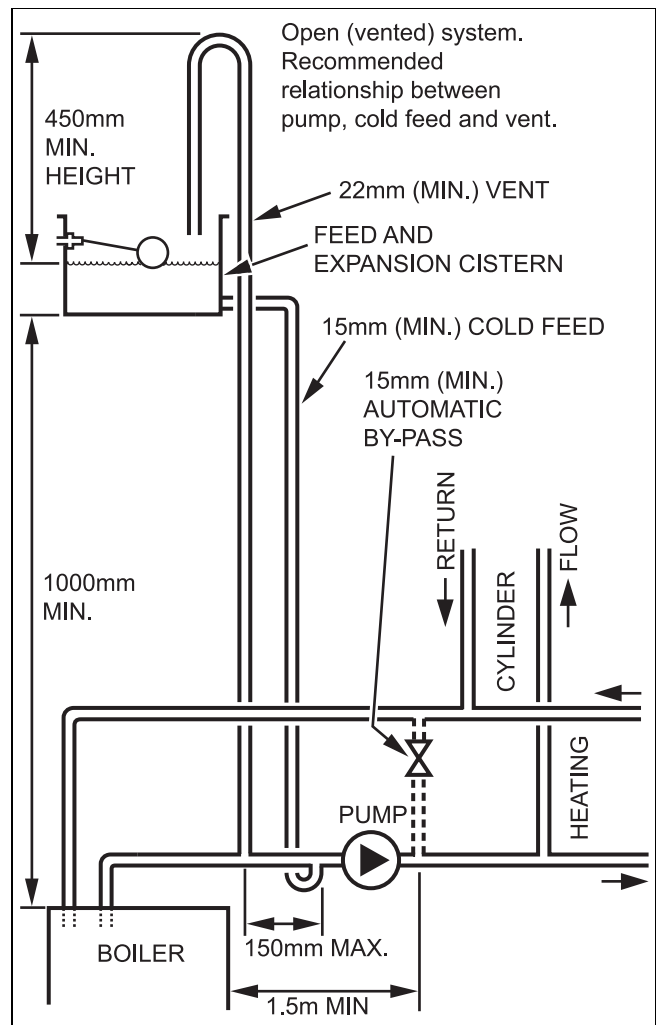

- ▶ Connect the product to a supply/expansion tank as shown in the figure.
  - The tank must not be more than 27 m (90 ft) above the product.
  - The open vent pipe must be installed with an upward gradient and must not be blocked.
  - Supply pipe diameter:  $\geq 15$  mm
  - The relative positions of the pump, supply and open vent pipe must be as shown in the figure.

**Condition:** Combined supply and open vent pipe

- ▶ Install the line in accordance with "BS 5449".
  - Diameter:  $\geq 22$  mm

## 7.4 Heating water supply in the sealed heating system

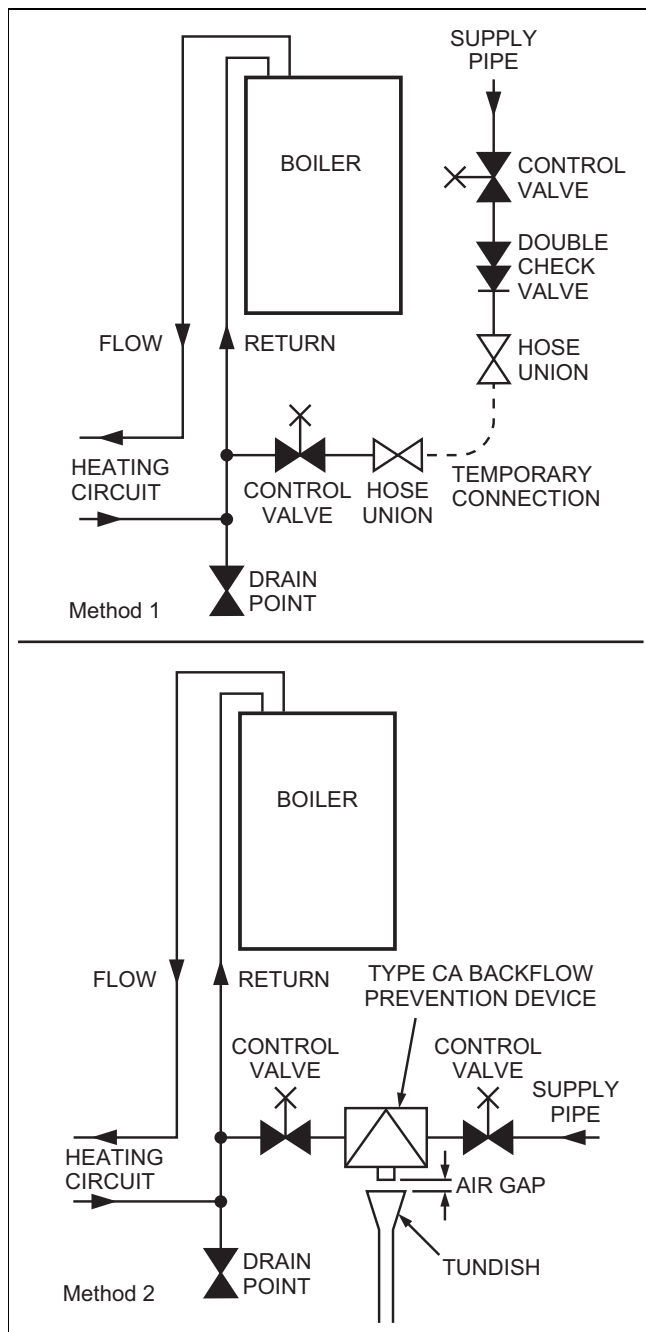

A safety valve must be fitted to a sealed system. It shall be preset, non-adjustable with a lift pressure of 3 bar, incorporating seating of a resilient material, a test device and a connection for drain. The drain from the safety valve must be routed outside the building, must not discharge above an entrance or window or any type of public access area, be clear of any electrical fittings and positioned so that any discharge can be seen.

A diaphragm type expansion vessel, conforming to the current issue of BS 4814 (see also BS 7074 Part 1 and 2) must be connected at a point close to the inlet side of the circulating pump, see the diagrammatic layout, above unless laid down differently by the manufacturer. The expansion vessel volume depends on the total water system volume and the initial system design pressure. For any system an accurate calculation of vessel size is given in the current issue of BS 5449 and BS 7074 Part 1. Example: For an initial design pressure of 0.7 bar, the minimum total vessel volume required is  $0.063 \times \text{Total System Volume}$ .



### Note

A higher initial design pressure requires a larger volume expansion vessel.

In GB, guidance on vessel sizing is also given in the current issue of BS 5449 and BS 7074 Part 1. In IE refer to the current edition of I.S. 813 "Domestic Gas Installations". The charge pressure must not be less than the static head of the system, that is, the height of the highest point of the system above the expansion vessel.

A pressure gauge with a set pointer and covering at least 0 to 4 bar (0 to 60 lb/in<sup>2</sup>) shall be fitted permanently to the system in a position where it can be seen when filling the system.

## 7.5 Connecting the heating flow and heating return

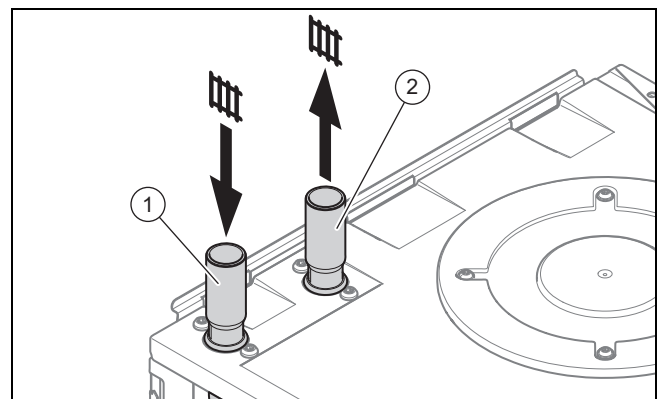

- 1 Heating return connection      2 Heating flow connection

1. Establish the heating connections in accordance with the applicable standards.
2. Check whether the connections (→ Page 30) are leak-tight.

## 7.6 Check compliance with the local gas group

The product's combustion has been factory tested and is preset for operation with the gas group indicated on the data plate.

The product is only authorised to be operated with natural gas.

- ▶ Check the information about the gas type indicated on the data plate and compare this with the gas type available at the installation site.

**Condition:** The product design is **not compatible** with the local gas group

- ▶ Do not start up the product.

**Condition:** The product design is **compatible** with the local gas group

- ▶ Proceed as described below.

## 7.7 Gas connection

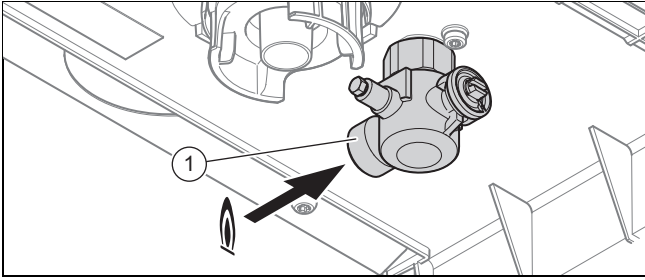

1. Establish the gas connection (1) in accordance with the applicable standards.
2. Purge the gas pipe before start-up.
3. Check the entire gas pipe properly for leak-tightness.

## 7.8 Connecting the condensate discharge pipe

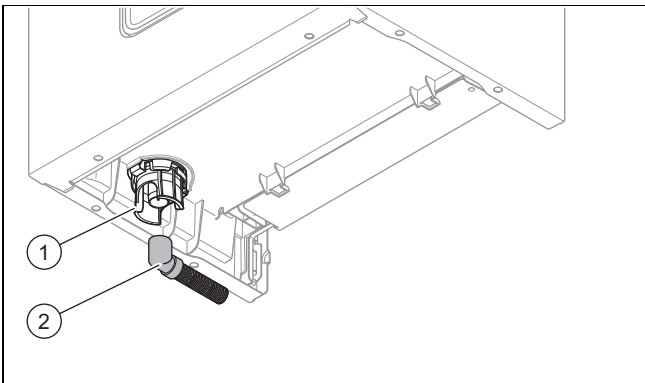

- ▶ Follow the instructions listed here and observe the legal and local regulations on condensate discharge.
- ▶ Use PVC or any other material that is suitable for draining the non-neutralised condensate.
- ▶ If you cannot guarantee that the materials from which the drain pipework is made are suitable, install a system for neutralising the condensate.



### Note

The condensate drain pipework must have a continuous fall (45 mm per metre) and should whenever possible terminate at a suitable drain point within the heated envelope of the building that will remain frost free under long periods of low external temperatures.

- ▶ Connect the condensate traps (1). Use the supplied drain hose (2) for this.



### Note

Ensure that the connection between the condensate discharge pipe and the drain hose is not air-tight.

- ▶ Connect a condensate discharge pipe (21.5 mm, not included in the scope of delivery) to the drain hose (2).
- ▶ During installation remove all burrs from inside of cut pipe work and avoid excessive adhesive which may trap small pockets of water close to the pipe wall which can freeze and build into a larger ice plug.
- ▶ For any installation the condensate must be free flowing and not be possible for air back-pressure to prevent water flow.

- ▶ As with other pipe work insulate the condensate discharge pipe to minimise any risk of freezing and beware when crossing cavities that the fall is maintained and the pipe sleeved.

You can find further information in specification "BS 6798" for installing and maintaining gas-fired boilers with a nominal heat input below 70 kW.

## 7.8.1 Condensate discharge systems

It is not necessary to provide extra traps in the discharge pipe as there is already a trap inside the boiler. Fitting an extra trap may cause the boiler siphon to work incorrectly. Refer to BS5546 or BS6798 for further advice on disposal of boiler condensate.

### 7.8.1.1 Direct Connection to internal soil and vent stack

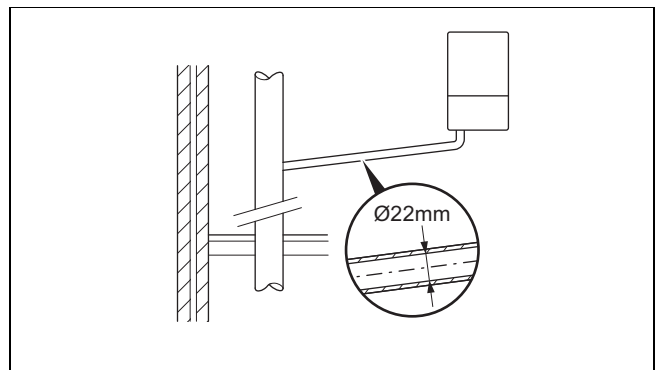

Preferred option

### 7.8.1.2 Direct connection to external soil and vent stack

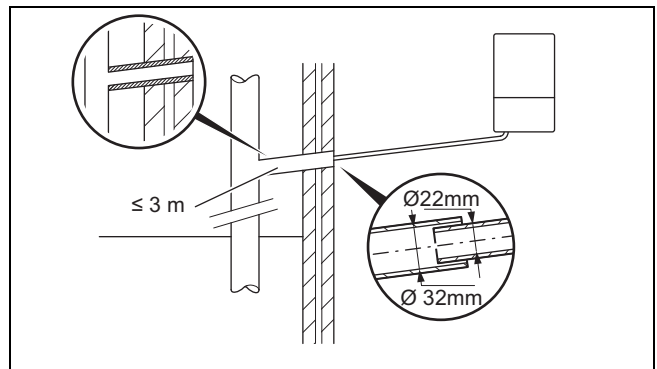

### 7.8.1.3 External termination to gully or hopper

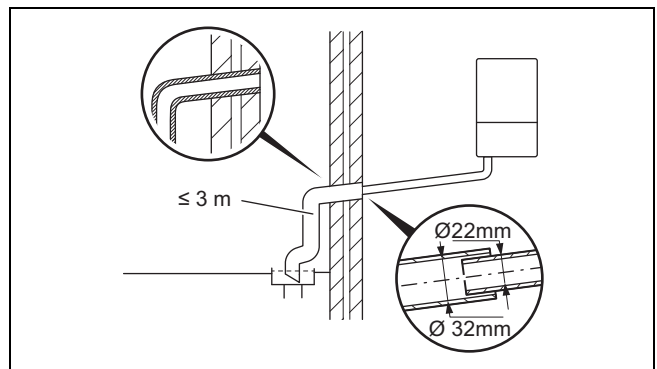

Best practice

**7.8.1.4 Internal termination into combined sink waste**

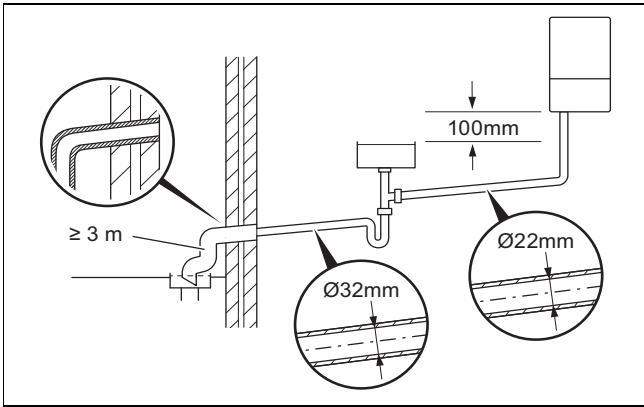

Preferred option for external termination

**7.8.1.5 External termination into soakaway**

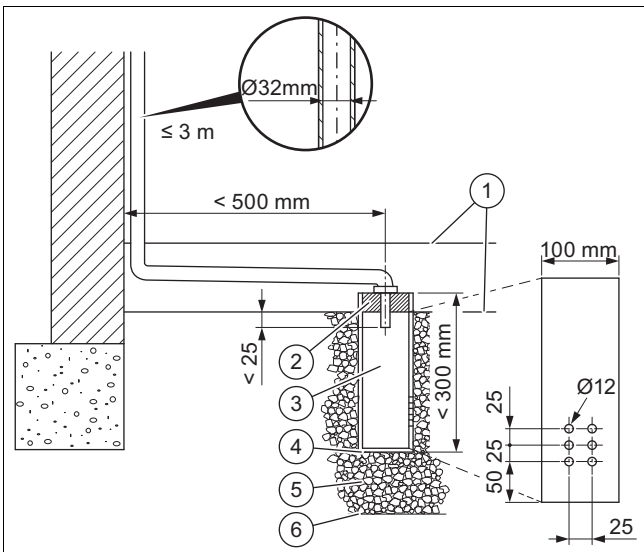

- |   |                               |   |                           |
|---|-------------------------------|---|---------------------------|
| 1 | Ground (either/or)            | 4 | Bottom of sealed tube     |
| 2 | Seal                          | 5 | Limestone chippings       |
| 3 | Plastic tube, 100 mm diameter | 6 | Hole depth 400 mm minimum |

Least preferred option, must not terminate in rain water drain

**7.8.1.6 Internal termination downstream of sink waste**

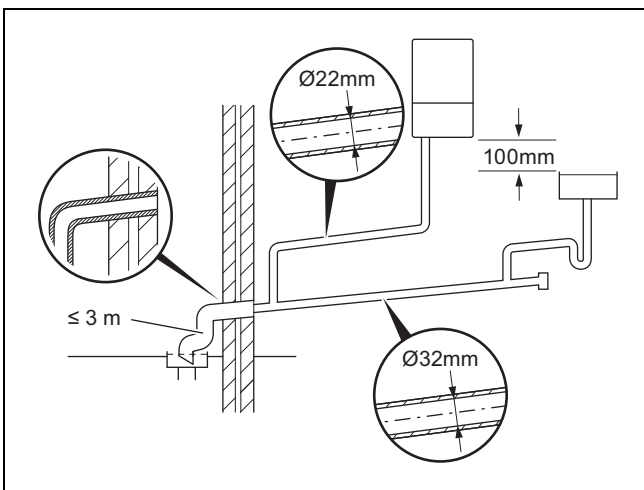

Open end of pipe direct into gulley below ground level but above water level

Susceptible to siphonage, must terminate in a gulley

**7.8.1.7 External termination into rain water down pipe**

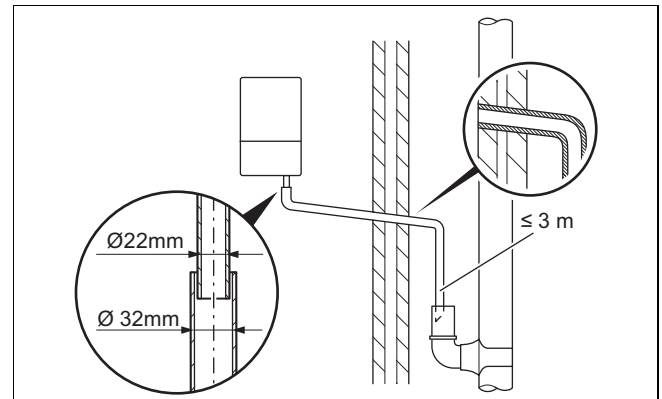

NB only combined foul/rainwater drain

**7.8.1.8 Additional methods of introducing air breaks**

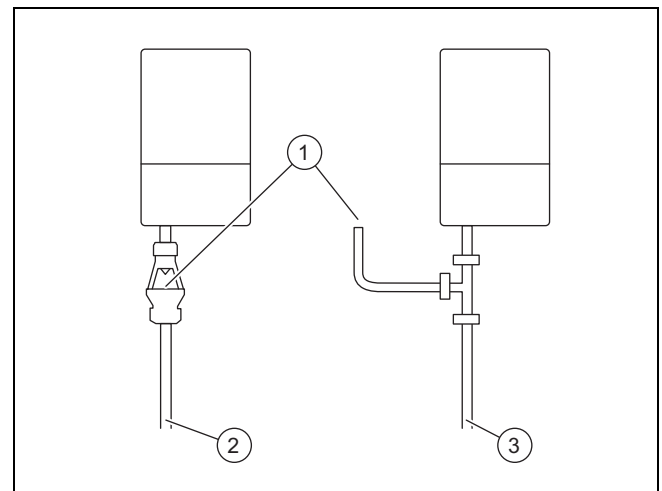

- |   |                 |   |              |
|---|-----------------|---|--------------|
| 1 | Air break       | 3 | Using a pipe |
| 2 | Using a tundish |   |              |

**7.8.1.9 Connection of condensate pump**

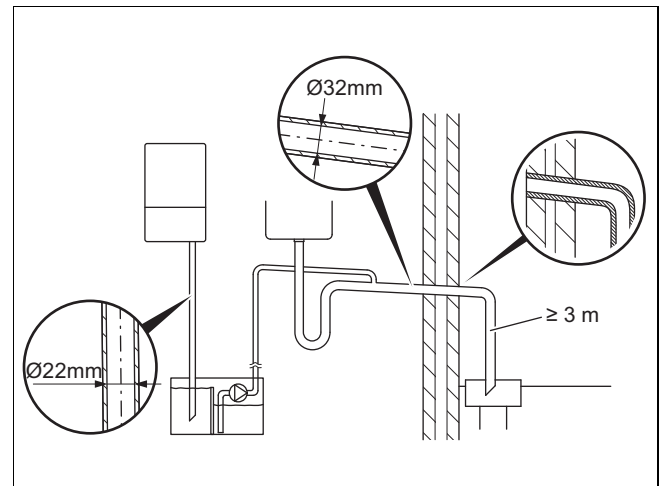

Preferred option for external connection

## 7.9 Flue installation

### 7.9.1 Installing and connecting the air/flue pipe

1. You can find out which air/flue pipes may be used by consulting the enclosed set-up instructions for the air/flue system.
2. Observe the information on positioning the air/flue terminal.

**Condition:** Installation in damp rooms

- ▶ You must connect the product to a room-sealed air/flue system. The combustion air must not be taken from the installation site.
3. Install the air/flue pipe using the set-up instructions.

## 7.10 Electrical installation

Only qualified electricians may carry out the electrical installation.

The product must be earthed.



### **Danger!**

#### **Risk of death from electric shock!**

Continuous voltage is present at power supply terminals L and N even when the unit is switched off using the standby button.

- ▶ Switch off the power supply.
- ▶ Secure the power supply against being switched on again.

### 7.10.1 Opening the electronics box

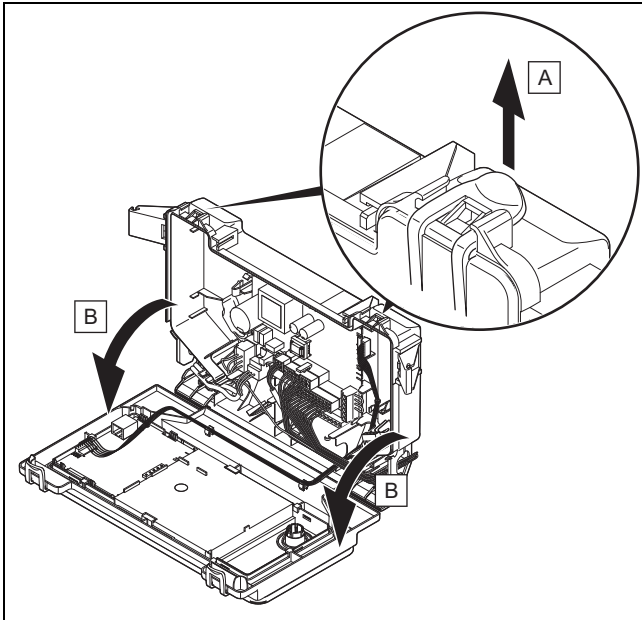

### 7.10.2 Cable route

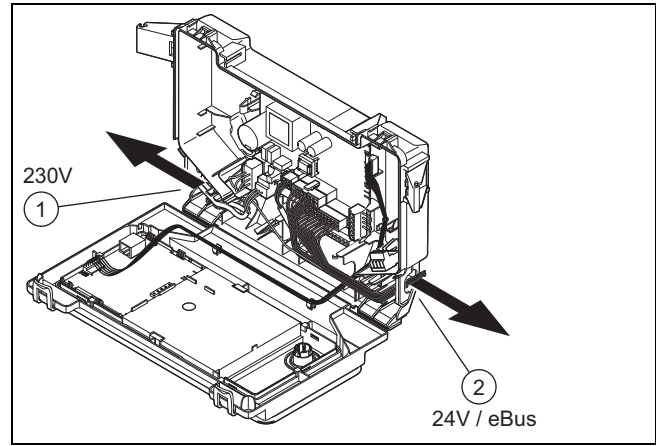

1 230 V cable route

2 24-V cable or eBUS cable route

### 7.10.3 General information about connecting cables



#### **Caution.**

#### **Risk of material damage caused by incorrect installation.**

Mains voltage at incorrect terminals and plug terminals may destroy the electronics.

- ▶ Do not connect any mains voltage to the eBUS (+/-) and RT 24 V terminals.
- ▶ Only connect the connection cable to the terminals marked for the purpose.

1. Route the connection cables of the components to be connected through the grommet provided on the underside of the product on the left.
2. Ensure that the grommet is plugged in correctly and that the cables have been routed correctly.
3. Ensure that the grommets envelop the connection cables tightly and with no visible gaps.
4. Use strain reliefs.
5. If required, shorten the connection cables.

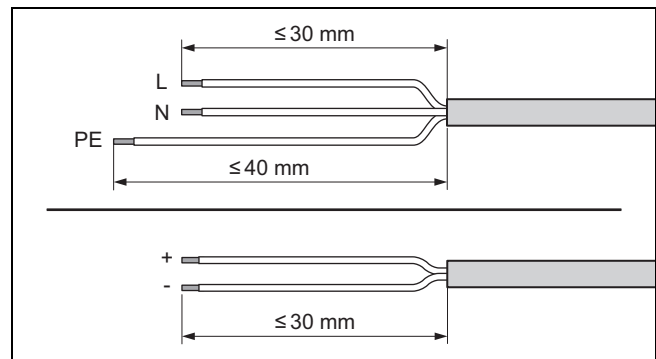

6. Strip the flexible cables as shown in the figure. In doing so, ensure that the insulation on the individual conductors is not damaged.
7. Only strip inner conductors just enough to establish stable connections.
8. To avoid short circuits resulting from loose individual wires, fit conductor end sleeves on the stripped ends of the conductors.

9. Screw the respective plug to the connection cable.
10. Check whether all conductors are inserted mechanically securely in the terminals of the plug. Remedy this if necessary.
11. Plug the plug into the associated PCB slot.
  - In doing so, observe the wiring diagram in the appendix.

#### 7.10.4 Establishing the power supply

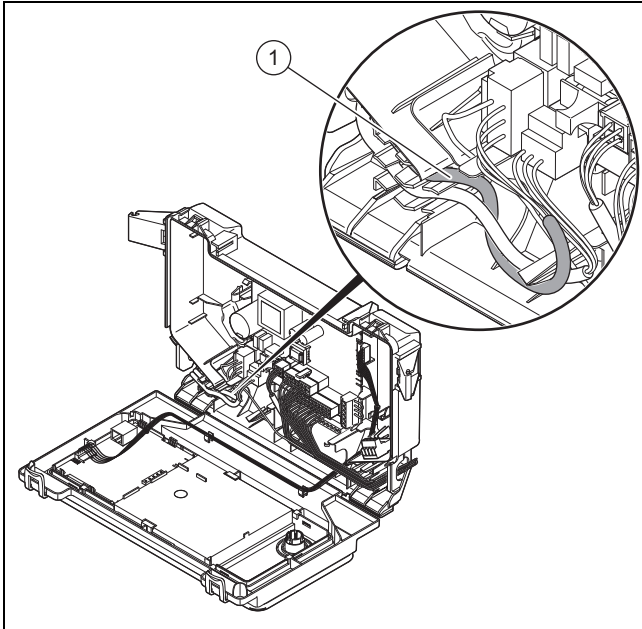

1. Observe all valid regulations.
2. Ensure that the nominal mains voltage is 230 V.
3. Do not interrupt the mains supply with a time switch or programmer.
4. Set up a fixed connection and install a partition with a contact gap of at least 3 mm (e.g. fuses or power switches).
5. Isolation should preferably be by a double pole switched fused spur box having a minimum contact separation of 3mm on each pole. The fused spur box should be readily accessible and preferably adjacent to the boiler. It should be identified as to its use.
6. Provide one common power supply for the boiler and for the corresponding control:
  - Power supply: Single-phase, 230 V, 50 Hz
  - Fuse protection:  $\leq 3$  A
7. Open the electronics box. (→ Page 23)
8. Observe the routing of the power supply cable (1) in the electronics box in order to guarantee that there is no strain.

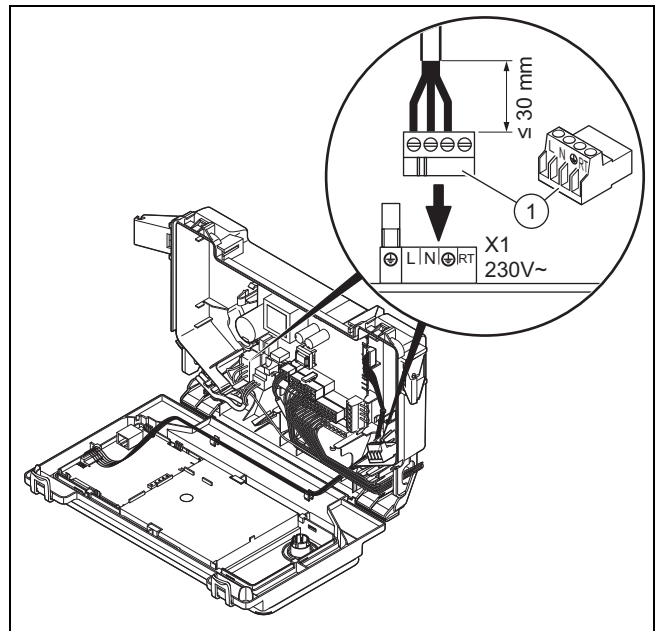

9. Connect the cables. (→ Page 23)
10. Close the electronics box.
11. Make sure that access to the power supply is always available and is not covered or blocked.

#### 7.10.5 Connecting the heating pump

- ▶ Connect the heating pump to the boiler; see the wiring diagram in the appendix.

#### 7.10.6 Connecting controls to the electronics

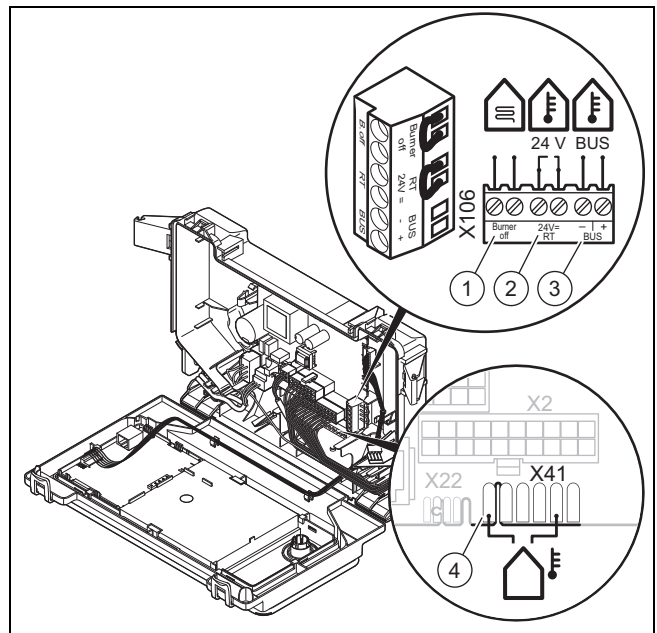

- |  |                                       |
|--|---------------------------------------|
| 1 Safety thermostat for underfloor heating | 3 eBUS control or radio receiver unit |
| 2 24 V control                             | 4 Outdoor temperature sensor, wired   |

1. Ensure that the product is voltage-free.
2. Connect the cables. (→ Page 23)
3. Connect the individual components depending on the installation type.

**Condition:** If installing a multi-circuit control.

- ▶ Change the pump mode **d.18** from Eco (intermittent pump operation) to Comfort (continuous pump operation).

**Condition:** When connecting a control (230 V).

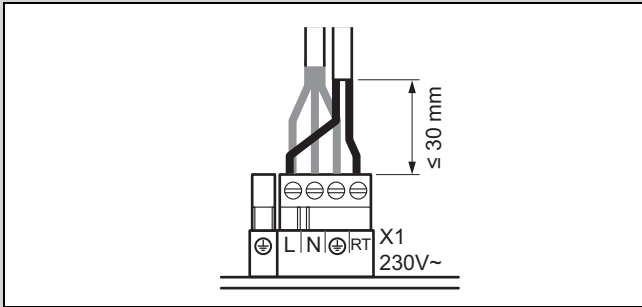

- ▶ Connect the control to the main plug.

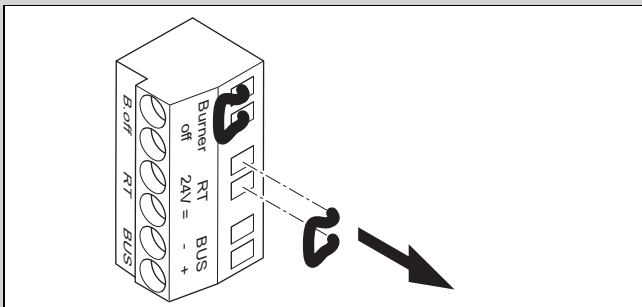

- ▶ Remove the bridge from the **24V=RT** plug.

**Condition:** 230 V 3-wire connection

- ▶ Ensure that the control is designed for a maximum nominal current of 7 A.
- ▶ Connect the boiler only using the set with article number 0020244337 (Installation Kit, 3-wire, Vaillant).
  - When connecting, observe the instructions for the set.
- ▶ Connect the control to the main plug X1.
  - Terminal assignment: L – Phase, N – neutral conductor, ⊕ – earth
- ▶ Draw the end user's attention to the fact that the following features are present with this installation type.
  - ◁ The frost protection function is deactivated. If the product is installed in a room where there is a risk of frost and it has not been protected by a room thermostat, install an additional frost protection thermostat.
  - ◁ The pump programmes are not active.
  - ◁ If the product is switched off, the display is switched off.
  - ◁ Each time the unit is started, the fan runs for 20 seconds.
  - ◁ Residual heat in the heating return may result in the product blocking the burner for 10 minutes.

4. Close the electronics box.

## 8 Operation

### 8.1 Operating concept

The operating concept and the display and setting facilities of the operator level are described in the operating instructions.

An overview of the display and setting options in the installer level can be found in the section "Overview of the installer level". (→ Page 26)

### 8.2 Installer level overview

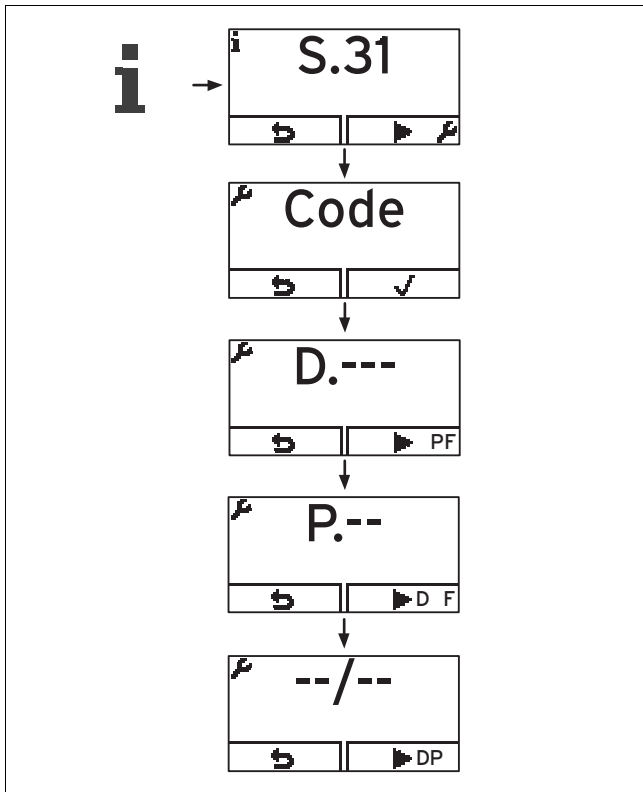

### 8.3 Calling up the installer level

1. Only call up the installer level if you are a competent person.
2. Press and ("i") at the same time.  
 < S.xx appears in the display (current unit status).
3. Press to access the installer level.  
 < Code and -- appear in the display.
4. Set the value 17 (code) and confirm by pressing .
5. Press to access the check programmes (P) and the fault codes (F) and to return to the diagnostics codes (D).
6. Use or to set the required value and confirm by pressing .
7. Confirm by pressing .
8. Press to cancel a setting or exit the installer level.

### 8.4 Live Monitor (status codes)

Menu → Live monitor

Status codes in the display provide information on the product's current operating status.

Status codes – Overview (→ Page 41)

### 8.5 Using check programmes

Call up the installer level + 1 x

Display	Meaning
P.00	<p>Purging check programme:            The internal pump is cyclically actuated.            The heating circuit and the hot water circuit are purged via the automatic air vent (the cap of the automatic air vent must be released).</p> <p>1 x : Start heating circuit purging            2 x  ( → ): Start domestic hot water circuit purging            3 x  ( → ): Restart heating circuit purging            1 x  (Cancel): End purge programme</p> <p><b>Note</b>            The purge programme runs for 7.5 min per circuit and then terminates.            Purging the heating circuit:            Prioritising diverter valve in heating position, actuation of internal pump for 9 cycles: 30 sec. on, 20 sec. off. Display: <b>Active heating circuit</b>.            Purging the hot water circuit:            After the above-mentioned cycles have run or the right-hand selection button has been pressed again: Prioritising diverter valve in the domestic hot water position, actuation of the internal pump as above. Display: <b>Active hot water circuit</b>.</p>
P.01	<p>Maximum load check programme:            After successful ignition, the product is operated at maximum heat input.</p>
P.02	<p>Minimum load check programme:            After successful ignition, the product is operated at minimum heat input.</p>
P.06	<p>Filling mode check programme:            The prioritising diverter valve is moved to the mid-position. The burner and pump are switched off (to fill or drain the product).</p>

## 9 Start-up

### 9.1 Carrying out the initial start-up

Initial start-up must be carried out by a customer service technician or an authorised competent person using the benchmark checklist. The benchmark checklist in the appendix (→ Page 46) of the installation instructions must be filled out and stored carefully along with the unit's documentation.

- ▶ Carry out the initial start-up using the benchmark checklist in the appendix.
- ▶ Fill out and sign the benchmark checklist.

### 9.2 Checking and treating the heating water/filling and supplementary water



#### Caution.

**Risk of material damage due to poor-quality heating water**

- ▶ Ensure that the heating water is of sufficient quality.

- ▶ Before filling or topping up the installation, check the quality of the heating water.

#### Checking the quality of the heating water

- ▶ Remove a little water from the heating circuit.
- ▶ Check the appearance of the heating water.
- ▶ If you ascertain that it contains sedimentary materials, you must desludge the installation.
- ▶ Use a magnetic rod to check whether it contains magnetite (iron oxide).
- ▶ If you ascertain that it contains magnetite, clean the installation and apply suitable corrosion-inhibition measures, or fit a magnetic filter.
- ▶ Check the pH value of the removed water at 25 °C.
- ▶ If the value is below 6.5 or above 8.5, clean the installation and treat the heating water.
- ▶ Ensure that oxygen cannot get into the heating water.

#### Checking the filling and supplementary water

- ▶ Before filling the installation, measure the hardness of the filling and supplementary water.

#### Treating the filling and supplementary water

- ▶ Observe all applicable national regulations and technical rules when treating the filling and supplementary water.

Provided the national regulations and technical rules do not stipulate more stringent requirements, the following applies:

You must treat the heating water in the following cases

- If the entire filling and supplementary water quantity during the operating life of the system exceeds three times the nominal volume of the heating installation, or
- If the guideline values listed in the following table are not met, or
- If the pH value of the heating water is less than 6.5 or more than 8.5.

Total heating output	Water hardness at specific system volume <sup>1)</sup>					
	≤ 20 l/kW		> 20 l/kW ≤ 50 l/kW		> 50 l/kW	
kW	ppm CaCO <sub>3</sub>	mol/ m <sup>3</sup>	ppm CaCO <sub>3</sub>	mol/ m <sup>3</sup>	ppm CaCO <sub>3</sub>	mol/ m <sup>3</sup>
< 50	< 300	< 3	200	2	2	0.02
> 50 to ≤ 200	200	2	150	1.5	2	0.02
> 200 to ≤ 600	150	1.5	2	0.02	2	0.02
> 600	2	0.02	2	0.02	2	0.02

1) Nominal capacity in litres/heating output; in the case of multi-boiler systems, the smallest single heating output is to be used.



#### Caution.

**The use of unsuitable heating water may cause aluminium corrosion and a resulting lack of leak-tightness.**

In contrast to steel, grey cast iron or copper, for example, aluminium reacts with alkaline heating water (pH value > 8.5) to produce substantial corrosion.

- ▶ When using aluminium, make sure that the pH value of the heating water is between 6.5 and a maximum of 8.5.



#### Caution.

**Risk of material damage if the heating water is treated with unsuitable additives.**

Unsuitable additives may cause changes in the components, noises in heating mode and possibly subsequent damage.

- ▶ Do not use any unsuitable antifreeze and corrosion inhibitors, biocides or sealants.

No incompatibility with our products has been detected to date with proper use of the following additives.

- ▶ When using additives, follow the manufacturer's instructions without exception.

We accept no liability for the compatibility of any additive or its effectiveness in the rest of the heating system.

#### Additives for cleaning measures (subsequent flushing required)

- Adey MC3+
- Adey MC5
- Fernox F3
- Sentinel X 300
- Sentinel X 400

#### Additives intended to remain permanently in the installation

- Adey MC1+
- Fernox F1
- Fernox F2
- Sentinel X 100
- Sentinel X 200

### Additives for frost protection intended to remain permanently in the installation

- Adey MC ZERO
  - Fernox Antifreeze Alphi 11
  - Sentinel X 500
- ▶ If you have used the above-mentioned additives, inform the end user about the measures that are required.
- ▶ Inform the end user about the measures required for frost protection.

### 9.3 Filling the condensate trap

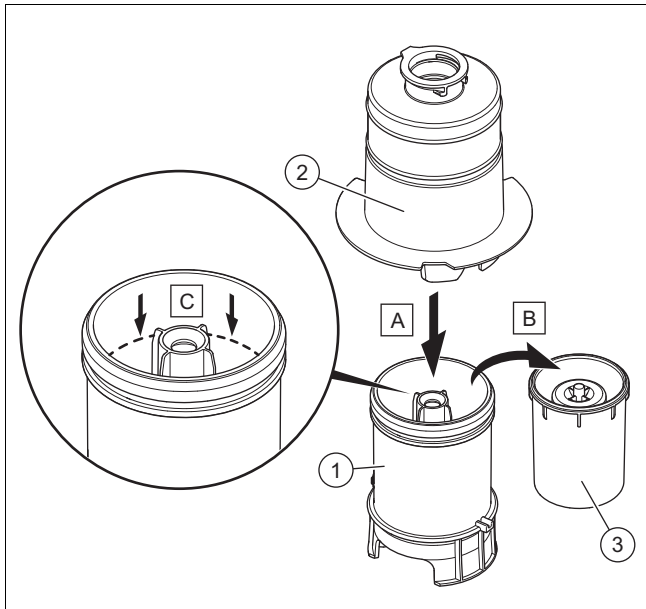

1. Unclip the lower section of the condensate trap (1) from the upper section of the condensate trap (2).
2. Remove the float (3).
3. Fill the lower section of the condensate trap with water up to 10 mm below the upper edge of the condensate discharge pipe.
4. Re-insert the float (3).



#### Note

Check whether the float is present in the condensate trap.

5. Clip the lower section of the condensate trap (1) into the upper section of the condensate trap (2).

### 9.4 Switching on the product

- ▶ Switch on the product via the main switch installed on-site.

### 9.5 Flushing the heating installation for the first time ("cold")



#### Note

The complete heating system must be flushed at least twice: Once with cold water and once with hot water in accordance with the following instructions.

1. Check whether all thermostatic radiator valves and both service valves on the product are open.
2. Connect a hose to the drain valve that is located at the lowest position in the heating system.
3. Open the radiator valves and the drain valves so that the water can drain quickly. Start at the next point in the installation and open the purging valves on the radiators so that the contaminated water can completely drain.
4. Close the drain cocks.
5. Refill the heating system with water.
6. Close the filling valve and the cold water tap.

### 9.6 Filling the heating installation

- ▶ Fill the heating installation with the maximum possible volume flow.

### 9.7 Checking the gas setting

Only a qualified competent person is authorised to implement the settings on the gas valve assembly.

Each destroyed seal must be replaced.

The CO<sub>2</sub> adjusting screw must be sealed.

Never modify the factory setting of the gas pressure regulator of the gas valve assembly.

#### 9.7.1 Checking the air/flue pipe/flue gas recirculation

1. Check the flue gas installation is intact in accordance with the latest gas safe technical bulletin and information supplied in the installation instructions.
2. For extended flue gas installations check for flue gas recirculation using the air analysis point.
3. Use a flue gas analyser.
4. If you discover unusual levels of CO or CO<sub>2</sub> in the supply air, search for the leak in the flue system or for signs of flue gas recirculation..
5. Eliminate the damage properly.
6. Check again whether the supply air contains any CO or CO<sub>2</sub>.
7. If you cannot eliminate the damage, do not start up the product.

#### 9.7.2 Checking the gas flow rate

The gas flow rate has been set during production and does not require adjustment. With the front casing fitted check the gas flow rate of the boiler as follows:

- ▶ Start up the product with the check programme **P.01**.
- ▶ In addition, ensure that maximum heat can be dissipated into the heating system by turning up the room thermostat.
- ▶ Wait at least 5 minutes until the boiler has reached its operating temperature.

- ▶ Ensure that all other gas appliances in the property are turned off.
- ▶ Measure the gas flow rate at the gas meter.
- ▶ Compare the measured values with the corresponding values in the table.

Q <sub>nw</sub> from the data plate	H gas in m <sup>3</sup> /h		
	Nom.	+5%	-10%
15.3	1.62	1.70	1.46
18.4	1.95	2.05	1.76
24.7	2.61	2.74	2.35
25.7	2.72	2.86	2.45
28.6	3.03	3.18	2.73
30.6	3.24	3.40	2.92
35.7	3.78	3.97	3.40

**Condition:** Gas flow rate not in the permissible range

- ▶ Check all of the piping and ensure that the gas flow rates are correct.
- ▶ Only put the product into operation once the gas flow rates have been corrected.

**Condition:** Gas flow rate in the permissible range

- ▶ End the check programme **P.01**.
- ▶ Allow the boiler to cool down by allowing pump overrun to operate for a minimum of 2 minutes.
- ▶ Record the boiler maximum gas flow rate onto the Benchmark gas boiler commissioning checklist.

### 9.7.3 Checking the gas connection pressure (gas flow pressure)

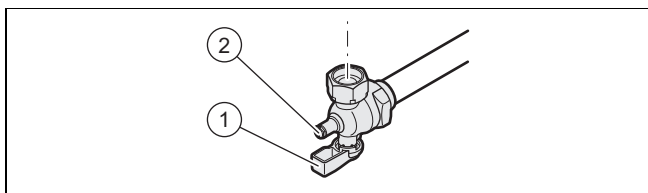

1. Ensure that the gas inlet working pressure can be obtained with all other gas appliances in the property working.
2. Close the gas stopcock **(1)**.
3. Undo the sealing screw on the test nipple **(2)**.
4. Connect a manometer to the test nipple **(2)**.
5. Open the gas stopcock **(1)**.
6. Start up the product with check programme **P.01** (system with eBUS control) or **P.03** (installation without eBUS control).
7. In addition, ensure that maximum heat can be dissipated into the heating system by turning up the room thermostat.
8. With the boiler operating at full load check that the gas inlet working pressure at the reference test point **(2)** complies with the requirements.

Permissible gas flow pressure for operation with	
Natural gas H	1.3 to 2.3 kPa (13.0 to 23.0 mbar)

9. Should the pressure recorded at the reference test point in the boiler be lower than indicated check if there is any blockage in the pipework or if the pipework is undersized.

**Condition:** Gas flow pressure **not** in the permissible range



#### Caution.

#### Risk of material damage and operating faults caused by incorrect gas connection pressure.

If the gas connection pressure lies outside the permissible range, this can cause operating faults in and damage to the product.

- ▶ Do not make any adjustments to the product.
- ▶ Do not start up the product.

- ▶ If you cannot correct the failure, notify the gas supply company and proceed as follows:
- ▶ End check programme P.01.
- ▶ Allow the boiler to cool down by allowing pump overrun to operate for a minimum of two minutes.
- ▶ Close the gas stopcock.
- ▶ Remove the pressure gauge and retighten the sealing screw **(2)** for the measuring nipple.
- ▶ Open the gas stopcock **(1)**.
- ▶ Check the test nipple for gas tightness.
- ▶ Close the gas stopcock **(1)**.
- ▶ Install the front casing. (→ Page 18)
- ▶ Disconnect the product from the electrical installation.
- ▶ You must not start up the boiler.

**Condition:** Gas flow pressure **in** the permissible range

- ▶ End the check programme **P.01**.
- ▶ Allow the boiler to cool down allowing pump overrun to operate for a minimum of two minutes.
- ▶ Close the gas stopcock **(1)**.
- ▶ Remove the pressure gauge and retighten the sealing screw **(2)** for the measuring nipple.
- ▶ Open the gas stopcock **(1)**.
- ▶ Check the test nipple for gas tightness.
- ▶ Remove the front casing. (→ Page 18)
- ▶ Reset boiler controls for normal operation.
- ▶ Record the appliance gas inlet working pressure (kPa resp. mbar) in the Benchmark gas boiler commissioning checklist.

### 9.7.4 Checking the CO<sub>2</sub> content

1. Start up the product with check programme **(P.01)**. Overview of the check programmes (→ Page 26)
2. Wait until the value that is read is stable.
  - Waiting period for reading a stable value: 5 min

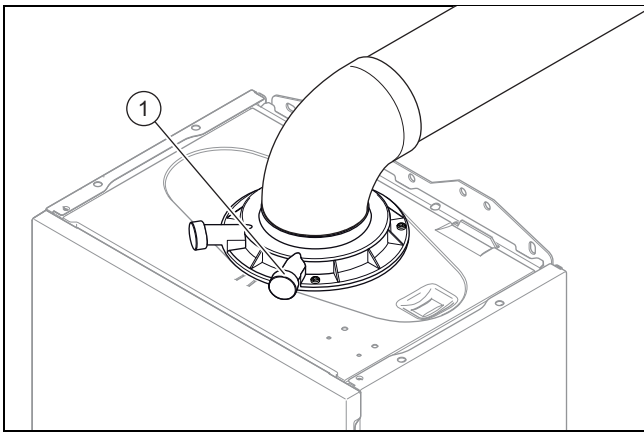

3. Unscrew the cover from the flue gas analysis point (1).
4. Measure the CO<sub>2</sub> content at the flue gas analysis point (1).
5. Compare the measured value with the corresponding value in the table.

Checking the CO <sub>2</sub> content	Removed front casing	Fitted front casing
	Natural gas H	Natural gas H
CO <sub>2</sub> at full load	9.0 ±1.0 vol. %	9.2 ±1.0 vol. %
CO at full load	≤ 250 ppm	≤ 250 ppm
CO/CO <sub>2</sub>	≤ 0.0031	≤ 0.0031

- ◁ The value is OK.
- ▽ The value is not OK; you cannot start up the product.
  - ▶ Inform Customer Service.

### 9.8 Thoroughly flushing the heating installation ("hot")

1. Operate the appliance until the boiler and the heating system are up to temperature.
2. Check the heating system for leaks.
3. Connect a hose to the drain valve located at the lowest position of the heating system.
4. Shut off the boiler, open the drain valve and all purge valves on the radiators and allow the water to flow out of the heating system and the boiler quickly and fully.
5. Close the drain valve.
6. Fill the heating system again with water as described in Filling the heating installation and Purging the heating installation.
7. Install the front casing.

### 9.9 Checking leak-tightness

- ▶ Check the gas pipe, the heating circuit and the hot water circuit for leak-tightness.
- ▶ Check that the air/flue pipe has been installed correctly.

**Condition:** Room-sealed operation

- ▶ Check whether the vacuum chamber has been closed tightly.

### 9.10 Checking the heating mode

1. Activate the heating mode on the user interface.
2. Turn all thermostatic valves on the radiators until they are fully open.
3. Allow the product to operate for at least 15 minutes.
4. Purge the heating installation.
5. Call up the **Live Monitor**.

– **Menu → Live Monitor**

Status codes – Overview (→ Page 41)

- ◁ If the product is working correctly, the display shows **S.04**.

## 10 Adapting the unit to the heating installation

You can reset/change the system parameters.

Overview of diagnostics codes (→ Page 38)

### 10.1 Burner anti-cycling time

To prevent frequent switching on and off of the burner and thus prevent energy losses, an electronic restart lockout is activated for a specific period each time the burner is switched off. The burner anti-cycling time is only active for the heating mode. Domestic hot water mode during a burner anti-cycling time does not affect the time function element.

#### 10.1.1 Setting the burner anti-cycling time

- ▶ Set the burner anti-cycling time via the diagnostics code.

Overview of diagnostics codes (→ Page 38)

T <sub>Flow</sub> (target) [°C]	Set maximum burner anti-cycling time [min]						
	1	5	10	15	20	25	30
30	2.0	4.0	8.5	12.5	16.5	20.5	25.0
35	2.0	4.0	7.5	11.0	15.0	18.5	22.0
40	2.0	3.5	6.5	10.0	13.0	16.5	19.5
45	2.0	3.0	6.0	8.5	11.5	14.0	17.0
50	2.0	3.0	5.0	7.5	9.5	12.0	14.0
55	2.0	2.5	4.5	6.0	8.0	10.0	11.5
60	2.0	2.0	3.5	5.0	6.0	7.5	9.0
65	2.0	1.5	2.5	3.5	4.5	5.5	6.5
70	2.0	1.5	2.0	2.5	2.5	3.0	3.5
75	2.0	1.0	1.0	1.0	1.0	1.0	1.0

T <sub>Flow</sub> (target) [°C]	Set maximum burner anti-cycling time [min]					
	35	40	45	50	55	60
30	29.0	33.0	37.0	41.0	45.0	49.5
35	25.5	29.5	33.0	36.5	40.5	44.0
40	22.5	26.0	29.0	32.0	35.5	38.5
45	19.5	22.5	25.0	27.5	30.5	33.0
50	16.5	18.5	21.0	23.5	25.5	28.0
55	13.5	15.0	17.0	19.0	20.5	22.5
60	10.5	11.5	13.0	14.5	15.5	17.0
65	7.0	8.0	9.0	10.0	11.0	11.5
70	4.0	4.5	5.0	5.5	6.0	6.5

T <sub>Flow</sub> (target) [°C]	Set maximum burner anti-cycling time [min]					
	35	40	45	50	55	60
75	1.0	1.0	1.0	1.0	1.0	1.0

### 10.1.2 Resetting the remaining burner anti-cycling time

- ▶ Press the reset button.

## 11 Handing over to the end user

- ▶ At the time of commissioning complete all relevant sections of the Benchmark commissioning checklist, located at the rear of this document.
- ▶ For IE: Complete a “Declaration of Conformity” to indicate compliance to I.S. 813. An example of this is given in the current edition of I.S. 813.
- ▶ When you have finished the installation, affix the enclosed sticker (which requests that the user reads the instructions) to the front of the product in the end user's language.
- ▶ Draw attention, to the current issue of the Gas Safety (Installation and Use) Regulations, Section 35, which imposes a duty of care on all persons who let out any property containing a gas appliance in the UK.
- ▶ Explain to the end user how the safety devices work and where they are located.
- ▶ Inform the end user how to handle the product.
- ▶ In particular, draw attention to the safety warnings that the end user must follow.
- ▶ Inform the end user that they must have the product maintained in accordance with the specified intervals.
- ▶ Pass all of the instructions and documentation for the product to the end user for safe-keeping.
- ▶ Inform the end user about measures taken to ensure the supply of combustion air and flue gas guiding, and instruct the operator that he must not make any changes.
- ▶ Inform the end user that they must not store or use explosive or highly flammable substances (such as petrol, paper or paint) in the installation room of the product.
- ▶ Complete and sign off the Benchmark commissioning check list.
- ▶ Complete and sign off the guarantee documentation.

## 12 Inspection and maintenance

### 12.1 Complete Service Interval Record section

- ▶ After servicing, complete the relevant Service Interval Record section of the Benchmark Checklist located on the inside back pages of this document.

### 12.2 Using original seals

If you replace components, use only the enclosed original seals; additional sealing materials are not required.

### 12.3 Observing inspection and maintenance intervals

- ▶ Adhere to the minimum inspection and maintenance intervals. The inspection may require maintenance to be carried out earlier, depending on the results.
  - Inspection and maintenance work (→ Appendix)

### 12.4 Checking the CO<sub>2</sub> content

1. Start up the product with check programme (P.01). Overview of the check programmes (→ Page 26)
2. Wait until the value that is read is stable.
  - Waiting period for reading a stable value: 5 min

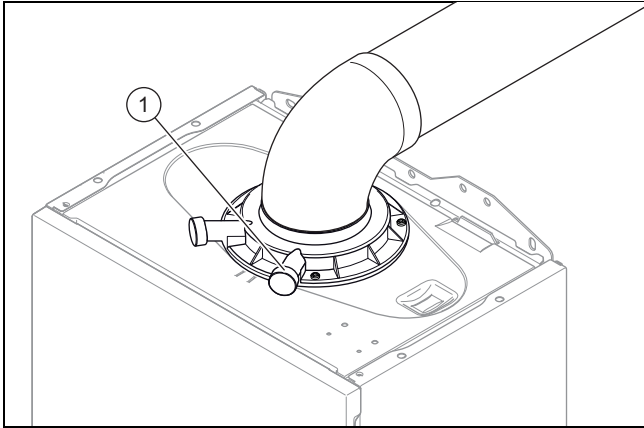

3. Unscrew the cover from the flue gas analysis point (1).
4. Measure the CO<sub>2</sub> content at the flue gas analysis point (1).
5. Compare the measured value with the corresponding value in the table.

Checking the CO <sub>2</sub> content	Removed front casing	Fitted front casing
	Natural gas H	Natural gas H
CO <sub>2</sub> at full load	9.0 ±1.0 vol. %	9.2 ±1.0 vol. %
CO at full load	≤ 250 ppm	≤ 250 ppm
CO/CO <sub>2</sub>	≤ 0.0031	≤ 0.0031

◁ The value is OK.

▽ The value is not OK; you cannot start up the product.

- ▶ Set the CO<sub>2</sub> content. (→ Page 32)

## 12.5 Setting the CO<sub>2</sub> content

Condition: CO<sub>2</sub> content needs adjustment

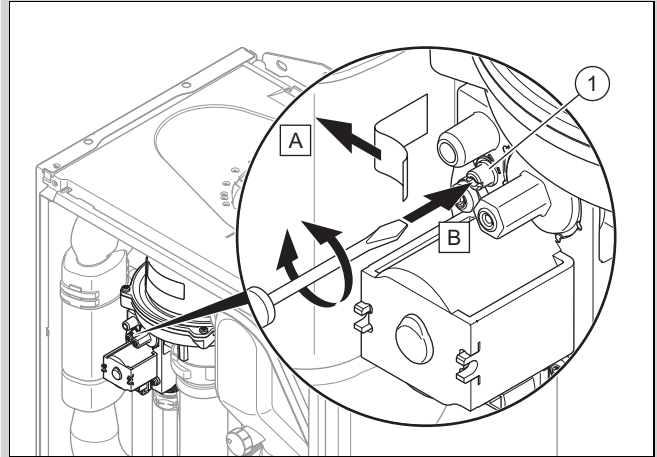

- ▶ Remove the sticker.
- ▶ Turn the screw (1) to set the CO<sub>2</sub> content (value with front casing removed).
  - ◁ To increase the CO<sub>2</sub> content: Turn anti-clockwise
  - ◁ To decrease the CO<sub>2</sub> content: Turn clockwise
- ▶ Only carry out the adjustment in increments of 1/8 turn and wait approximately 1 minute after each adjustment until the value has stabilised.
- ▶ Compare the measured value with the corresponding value in the table.

Setting the CO <sub>2</sub> content	Removed front casing	Fitted front casing
	Natural gas H	Natural gas H
CO <sub>2</sub> at full load	9.0 ±0.2 vol. %	9.2 ±0.2 vol. %
Set for Wobbe index W <sub>0</sub>	14.09 kW-h/m <sup>3</sup>	14.09 kW-h/m <sup>3</sup>
O <sub>2</sub> at full load		4.5 ±1.8 vol. %
CO at full load	≤ 250 ppm	≤ 250 ppm
CO/CO <sub>2</sub>	≤ 0.0028	≤ 0.0028

▽ If the setting is not in the specified adjustment range, you must not start up the product.

- ▶ Inform Customer Service.

- ▶ Check whether the air-quality requirements with regard to carbon monoxide are fulfilled.
- ▶ Install the front panel.

## 12.6 Removing the gas-air mixture unit



### Note

The gas-air mixture unit consists of three main components:

- Fan
- Gas valve assembly
- Burner hood

1. Switch off the product via the main switch.
2. Close the gas stopcock.
3. Remove the front casing. (→ Page 18)

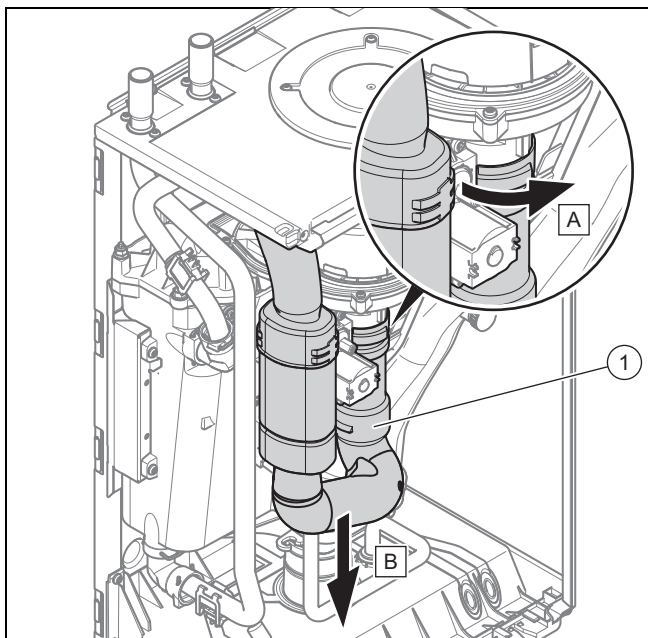

4. Remove the air intake pipe (1).

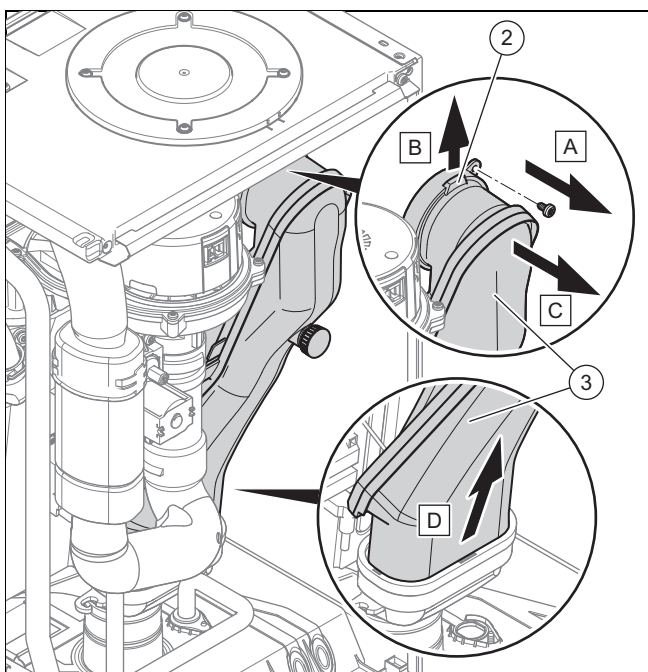

5. Push the clip (2) upwards.
6. Remove the flue pipe (3).

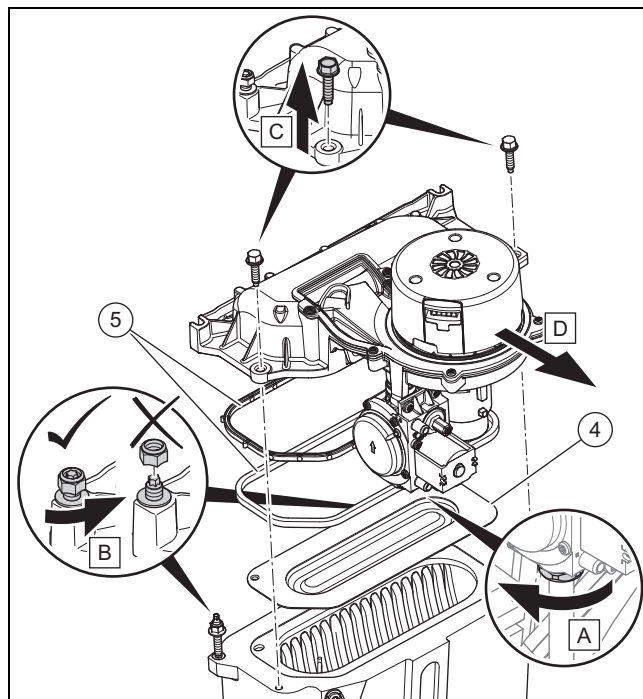

7. Remove the plugs from the gas valve assembly.
8. Remove the gas-air mixture unit .
9. Remove both burner seals (5) from the burner hood.
10. Remove the burner (4).

### 12.7 Cleaning the heat exchanger

1. Check the heat exchanger for damage and dirt.
2. If required, clean and replace the heat exchanger.
3. Protect the open electronics box from spraying water.

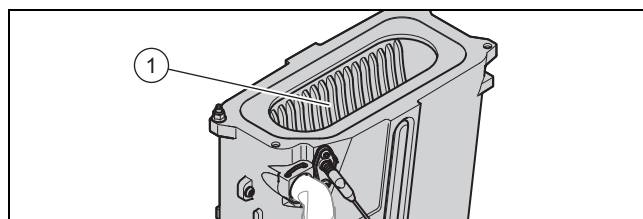

4. Clean the ribs of the heat exchanger (1) with water.  
 < The water runs out via the condensate tray.

### 12.8 Checking the burner

1. Check the surface of the burner for damage. If you see any damage, replace the burner.
2. Install the two new burner seals.

### 12.9 Checking the ignition electrode

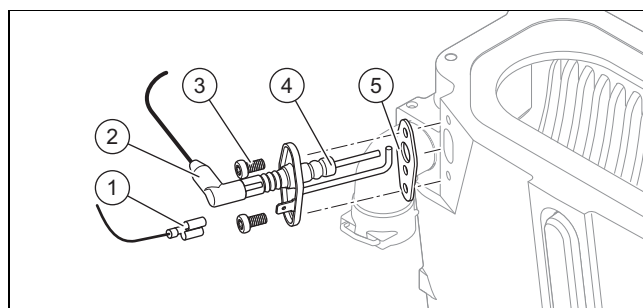

1. Disconnect the connection (2) and the earth cable (1).
2. Remove the fixing screws (3).

3. Carefully remove the electrode from the combustion chamber.
4. Check that the electrode ends (4) are undamaged.
5. Check the electrode distance.
  - Clearance for the ignition electrodes: 3.5 to 4.5 mm
6. Make sure that the seal (5) is free from damage.
  - ▽ If necessary, replace the seal.

### 12.10 Cleaning the condensate trap

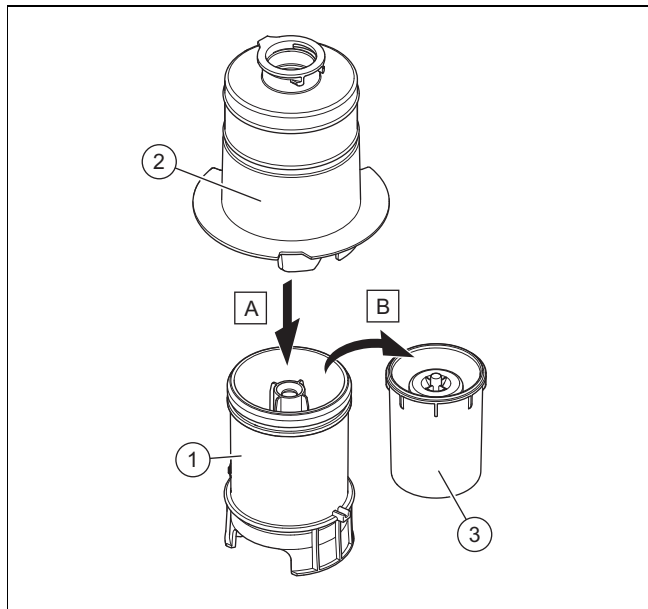

1. Unclip the lower section of the condensate trap (1) from the upper section of the condensate trap (2).
2. Remove the float (3).
3. Flush out the float and lower section of the condensate trap with water.
4. Fill the lower section of the condensate trap with water up to 10 mm below the upper edge of the condensate discharge pipe.
5. Re-insert the float (3).



#### Note

Check whether the float is present in the condensate trap.

6. Clip the lower section of the condensate trap (1) into the upper section of the condensate trap (2).

### 12.11 Installing the gas-air mixture unit

1. Install the burner.
2. Install two new burner seals in the burner hood.
3. Install the gas-air mixture unit.
4. Tighten the screws in a cross-wise pattern until the burner flange fits closely and uniformly onto the mating surfaces.
  - Tightening torque: 7 Nm, if a torque spanner is available
5. Install the flue pipe.
6. Install the air intake pipe.

### 12.12 Completing inspection and maintenance work

1. Check the gas connection pressure (gas flow pressure). (→ Page 29)
2. Check the CO<sub>2</sub> content. (→ Page 32)
3. If required, set the maintenance interval.
4. Check the product for tightness. (→ Page 30)
5. Install the front casing. (→ Page 18)
6. Fill out the relevant Service Record section in the Benchmark Checklist located at the rear of this document.

## 13 Troubleshooting

### 13.1 Eliminating faults

- ▶ If fault messages (F.xx) appear, eliminate the fault after referring to the table in the appendix or using the check programmes. (→ Page 26)
- Overview of fault codes (→ Page 42)

If several faults occur at the same time, the display shows the corresponding fault messages for two seconds each in alternation.

- ▶ Press (max. three times) to restart the product.
- ▶ If you are unable to eliminate the fault and the fault recurs despite reset attempts, contact customer service.

### 13.2 Calling up and clearing the fault memory

The last 10 fault messages are stored in the fault memory.

- ▶ Call up the installer level. (→ Page 26)
- ▶ Navigate to the **fault codes**.
  - ◀ The number of faults that have occurred is shown in the display and the faults that are currently called up are displayed with their fault numbers **F.xx**.
- ▶ Press or to call up individual fault messages.
- ▶ To delete the entire fault list, navigate to diagnostics code **D.094** in the installer level.
- ▶ Set the diagnostics code to 1, and confirm by pressing .

### 13.3 Resetting parameters to factory settings

1. Navigate to diagnostics code **D.096** in the installer level.
2. Set the diagnostics code to 1, and confirm by pressing .

### 13.4 Preparing the repair work

1. Decommission the product.
2. Disconnect the product from the electrical installation.
3. Remove the front casing.
4. Close the gas stopcock.
5. Close the service valves in the heating flow and in the heating return.
6. Close the service valve in the cold water pipe.
7. Drain the product if you want to replace water-carrying components of the product.
8. Ensure that water does not drip on live components (e.g. the electronics box).
9. Use only new seals and O-rings. Do not use any additional components.

### 13.4.1 Procuring spare parts

The original components of the product were also certified by the manufacturer as part of the declaration of conformity. If you use other, non-certified or unauthorised parts during maintenance or repair work, this may void the conformity of the product and it will therefore no longer comply with the applicable standards.

We strongly recommend that you use original spare parts from the manufacturer as this guarantees fault-free and safe operation of the product. To receive information about the available original spare parts, contact the contact address provided on the back page of these instructions.

- ▶ If you require spare parts for maintenance or repair work, use only the spare parts that are permitted for the product.

## 13.5 Replacing defective components

### 13.5.1 Replacing the burner

1. Remove the gas-air mixture unit. (→ Page 32)
2. Remove the two burner seals.
3. Remove the burner .
4. Insert the new burner.
5. Insert two new burner seals in the burner hood.
6. Install the gas-air mixture unit. (→ Page 34)

### 13.5.2 Replacing the gas-air mixture unit

1. Remove the gas-air mixture unit. (→ Page 32)
2. Install the new gas-air mixture (→ Page 34).

### 13.5.3 Replacing the heat exchanger

1. Remove the side section. (→ Page 18)
2. Remove the gas-air mixture unit. (→ Page 32)

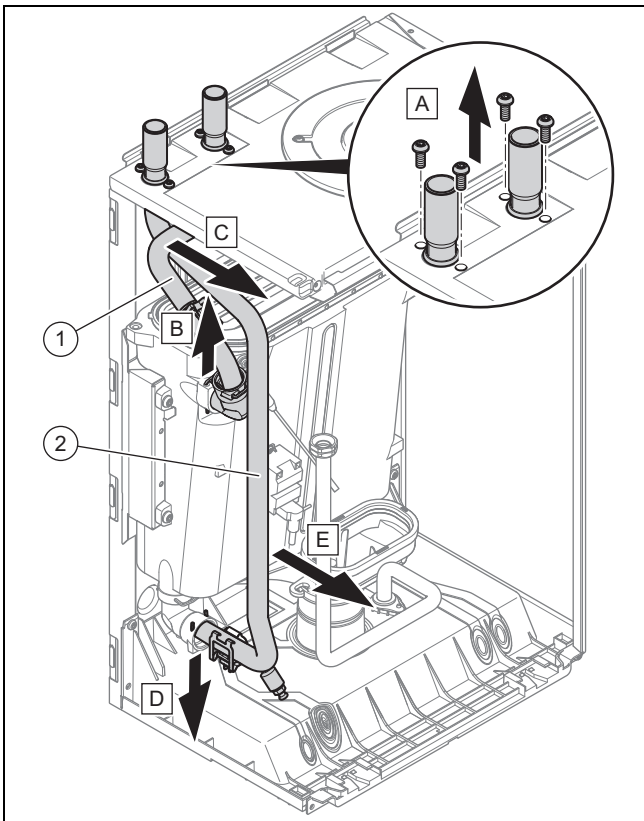

3. Remove the flow pipe (1).
4. Remove the return pipe (2).

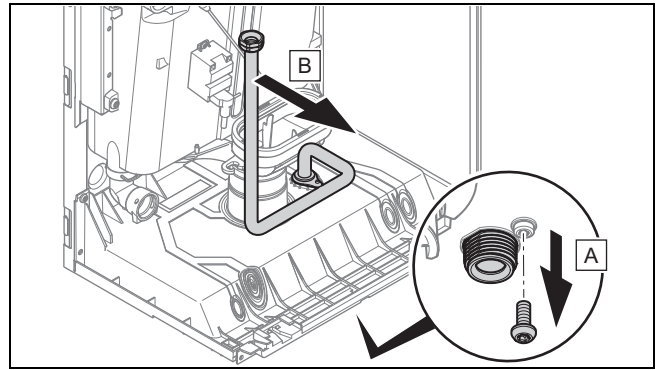

5. Remove the gas pipe .

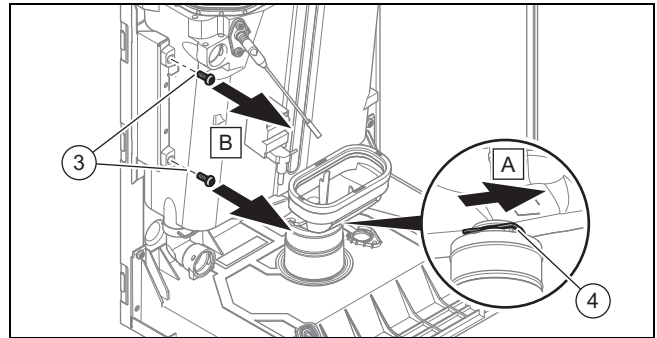

6. Undo the clip underneath the condensate tray (4).
7. Undo the two screws (3).

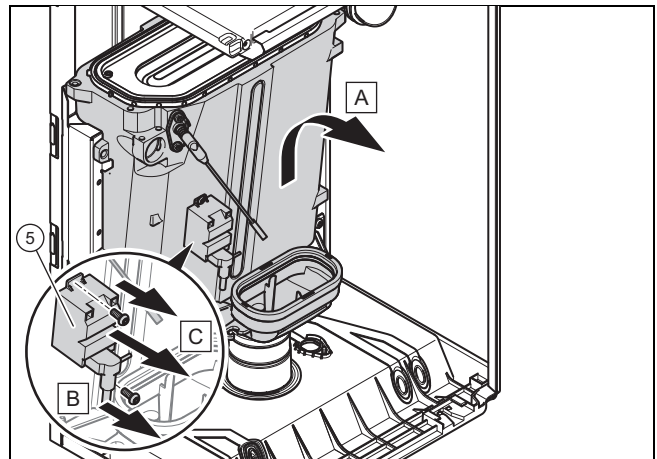

8. Lift the heat exchanger up slightly and remove it together with the condensate tray.
9. Remove the ignition transformer (5).
10. Replace all the seals.
11. Install the new heat exchanger in reverse order.

### 13.5.4 Replacing the PCB

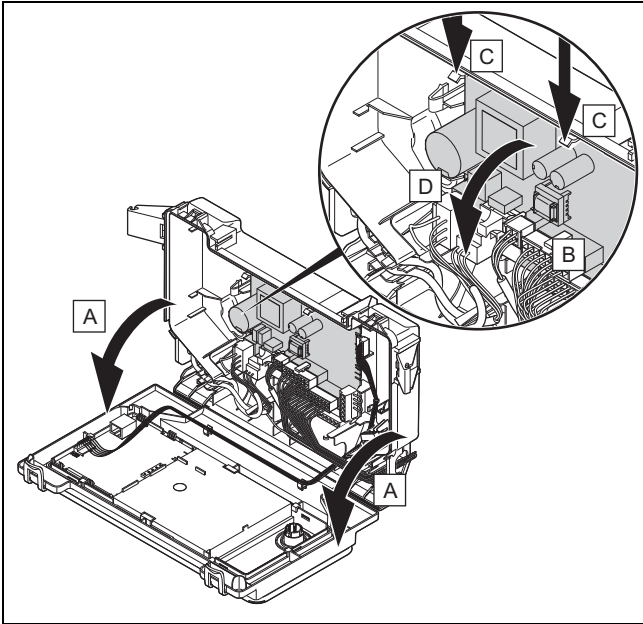

1. Open the electronics box. (→ Page 23)
2. Pull all of the plugs out from the PCB.
3. Undo the clips on the PCB.
4. Remove the PCB.
5. Install the new PCB in such a way that it clicks into the groove at the bottom and into the clip at the top.
6. Plug in the PCB plugs.
7. Close the electronics box.

### 13.5.5 Replacing the PCB for the user interface

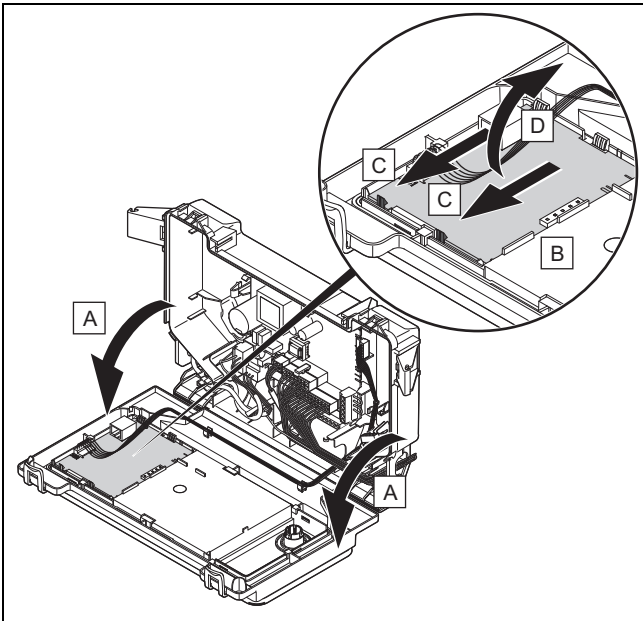

1. Open the electronics box. (→ Page 23)
2. Pull the plug out of the PCB.
3. Undo the clips on the PCB.
4. Remove the PCB.
5. Install the new PCB in such a way that it clicks into the groove at the bottom and into the clip at the top.
6. Plug in the PCB plug.
7. Close the electronics box.

### 13.6 Checking the product for leak-tightness

- ▶ Check that the product is leak-tight. (→ Page 30)

## 14 Decommissioning the product

- ▶ Switch off the product.
- ▶ Disconnect the product from the electrical installation.
- ▶ Close the gas stopcock.
- ▶ Close the cold-water isolation valve.

## 15 Recycling and disposal

### Disposing of the packaging

- ▶ Dispose of the packaging correctly.
- ▶ Observe all relevant regulations.
- ▶ For detailed information refer to [www.vaillant.co.uk](http://www.vaillant.co.uk).

## Appendix

### A Inspection and maintenance work

The table below lists the manufacturer requirements with respect to minimum inspection and maintenance intervals. If national regulations and directives require shorter inspection and maintenance intervals, you should observe these instead of the intervals listed. Each time inspection and maintenance work is carried out, carry out the required preparatory and completion work.



#### Note

For those appliances which are not part of an annual service agreement/policy, maintenance must be carried out at least every 5 years.

#	Maintenance work	Interval	
1	Record all of the analysis results in the Benchmark Checklist in these instructions	Annually	
2	Ask the end user whether any significant problems occur when operating the product	Annually	
3	Use the diagnostics system to check the product's fault history	Annually	
4	Visually inspect whether the air/flue pipe and its opening have been installed correctly in accordance with the set-up instructions	Annually	
5	Check that the unit has been installed correctly and the connections have been secured	Annually	
6	Check all of the connections for tightness	Annually	
7	Check that the condensate pipe is in good condition, that it is leak-tight and that the drain is correct	Annually	
8	Check whether all of the externally routed condensate pipes are dimensioned correctly and have been insulated sufficiently (frost protection)	Annually	
9	Check whether the gas flow rate corresponds with the specifications on the data plate and lies within the tolerances specified in these instructions	Annually	
10	If the gas flow rate lies outside of the tolerances specified in these instructions, eliminate the fault in accordance with the regulations and the current technology	Annually	
11	Check the general condition of the product and, if required, eliminate any faults that are found	Annually	
12	Carry out the combustion analysis: Measure the CO content, CO <sub>2</sub> content and the CO/CO <sub>2</sub> ratio. For products with a rear air/flue connection: The combustion analysis can only be carried out when the unit casing has been removed; it is not necessary to test these products for flue gas recirculation	Annually	
13	Check the product's recirculation at the supply air test point on the air/flue pipe. If required, inspect the entire air/flue system and, if necessary, correct the fault	Annually	
14	Disconnect the product from the electrical installation	Annually	
15	Check and, if required, correct the electrical installation	Annually	
16	Remove the unit casing, check the condition of all of the functional components, in particular for leaks, corrosion, rust, etc. and, if required, repair any damage	Annually	
17	Visual inspection of the heat exchanger and burner seals	Annually	
18	Carefully clean the inside of the product: The air passages to the burner must be clear and clean	Annually	
19	Close the installation's gas stopcock and, if required, service valves	Annually	
20	Check the quality of the heating water: Clarity (clouding), correct inhibitor and pH value	Annually	
21	Removing the gas-air mixture unit	at regular intervals	32
22	Checking the burner	at regular intervals	33
23	Cleaning the heat exchanger	at regular intervals	33
24	Check and, if required, replace the insulating mat in the burner area	at regular intervals	
25	Installing the gas-air mixture unit	at regular intervals	34
26	Cleaning the condensate trap	Annually	34
27	Filling the condensate trap	Annually	28

#	Maintenance work	Interval	
28	Reassemble the product	After each time maintenance work is carried out	
29	Opening the service valves	Annually	
30	Fill the product/heating installation to the filling pressure specified for the system	Annually	
31	Connect the product to the electrical installation	Annually	
32	Run the test operation on the product/heating installation including hot water generation (if available) and, if required, purge the product/heating installation	Annually	
33	Measure the CO content, CO <sub>2</sub> content and the CO/CO <sub>2</sub> ratio again	Annually	

## B Overview of diagnostics codes

Setting level	Values		Unit	Increment, select, explanation	Default setting	Own setting
	Min.	Max.				
<b>d.00 Heating maximum output</b>	–	–	kW	The maximum heating output varies depending on the product. → Section "Technical data"	→ Section "Technical data"	Adjustable
<b>d.01 Pump overrun time in heating mode</b>	1	60	min	1	5	Adjustable
<b>d.02 Burner anti-cycling time in heating mode</b>	2	60	min	1	20	Adjustable
<b>d.04 Water temperature in the cylinder</b>	Current value		°C	–	–	Not adjustable
<b>d.05 Determined target heating flow temperature</b>	Current value		°C	–	–	Not adjustable
<b>d.07 Target temperature for the domestic hot water cylinder</b>	Current value		°C	–	–	Not adjustable
<b>d.08 Status of the 230 V thermostat</b>	Current value		–	0 = Room thermostat open (no heat requirement) 1 = Room thermostat closed (heat requirement)	–	Not adjustable
<b>d.09 Target heating flow temperature that is set on the eBUS room thermostat</b>	Current value		–	–	–	Not adjustable
<b>d.10 Status of the internal pump in the heating circuit</b>	Current value		–	off / on	–	Not adjustable
<b>d.11 Status of the heating circuit's shunt pump</b>	Current value		–	off / on	–	Not adjustable
<b>d.13 Status of the domestic hot water circuit's circulation pump</b>	Current value		–	off / on	–	Not adjustable
<b>d.16 Status of the 24 V room thermostat</b>	Current value		–	off = Heating off on = Heating on	–	Not adjustable
<b>d.17 Heating control</b>	–	–	–	off = Flow temperature on = Return temperature (adjustment for underfloor heating. If you have activated the return temperature control, the automatic heating output determination function is not active.)	0	Adjustable
<b>d.18 Pump overrun operating mode</b>	1	3	–	1 = Comfort (continuously operating pump) 3 = Eco (intermittent pump operation – for the dissipation of the residual heat after domestic hot water generation at an extremely low heat demand)	1	Adjustable
<b>d.20 Maximum target domestic hot water temperature</b>	50	60	°C	1	50	Adjustable
<b>d.23 Status of the heat demand</b>	Current value		–	off = Heating off (Summer mode) on = Heating on	–	Not adjustable

Setting level	Values		Unit	Increment, select, explanation	Default setting	Own setting
	Min.	Max.				
<b>d.24 Status of the pressure switch</b>	0	1	–	off = Not switched on = Switched	–	Not adjustable
<b>d.25 Status of the requirement to reheat the cylinder or for the domestic hot water warm start from the eBUS thermostat</b>	Current value		–	off = Function deactivated on = Function activated	–	Not adjustable
<b>d.27 Function of relay 1 (multi-functional module)</b>	1	10	–	1 = Circulation pump 2 = External pump 3 = Cylinder charging pump 4 = Extraction hood 5 = External solenoid valve 6 = External fault message 7 = Solar pump (omitted) 8 = eBUS remote control 9 = Anti-legionella pump 10 = Solar valve	1	Adjustable
<b>d.28 Function of relay 2 (multi-functional module)</b>	1	10	–	1 = Circulation pump 2 = External pump 3 = Cylinder charging pump 4 = Extraction hood 5 = External solenoid valve 6 = External fault message 7 = Solar pump (omitted) 8 = eBUS remote control 9 = Anti-legionella pump 10 = Solar valve	2	Adjustable
<b>d.31 Automatic filling device</b>	0	2	–	0 = Manual 1 = Semi-automatic 2 = Automatic	0	Adjustable
<b>d.33 Fan speed target value</b>	Current value		rpm	Fan speed = Display value x 100	–	Not adjustable
<b>d.34 Value for the fan speed</b>	Current value		rpm	Fan speed = Display value x 100	–	Not adjustable
<b>d.40 Heating flow temperature</b>	Current value		°C	–	–	Not adjustable
<b>d.41 Heating return temperature</b>	Current value		°C	–	–	Not adjustable
<b>d.43 Heat curve</b>	0.2	4	–	0.1	1.2	Adjustable
<b>d.45 Value for the base point of the heat curve</b>	15	30	–	1	20	Adjustable
<b>d.47 Outdoor temperature</b>	Current value		°C	–	–	Not adjustable
<b>d.50 Correction of the minimum fan speed</b>	0	3000	rpm	1 Fan speed = Display value x 10	600	Adjustable
<b>d.51 Correction of the maximum fan speed</b>	-2500	0	rpm	1 Fan speed = Display value x 10	-1000	Adjustable
<b>d.58 Solar circuit reheating</b>	0	3	–	0 = Boiler's anti-legionella function deactivated 3 = Domestic hot water activated (target value min. 60 °C)	0	Adjustable
<b>d.60 Number of blocks by the temperature sensor</b>	Current value		–	–	–	Not adjustable
<b>d.61 Number of unsuccessful ignitions</b>	Current value		–	–	–	Not adjustable
<b>d.62 Night set-back</b>	0	30	–	1	0	Adjustable
<b>d.64 Average burner ignition time</b>	Current value		s	–	–	Not adjustable
<b>d.65 Maximum burner ignition time</b>	Current value		s	–	–	Not adjustable

Setting level	Values		Unit	Increment, select, explanation	Default setting	Own setting
	Min.	Max.				
d.66 Activation of the warm start function for domestic hot water	–	–	–	off = Function deactivated on = Function activated	1	Adjustable
d.67 Remaining burner anti-cycling time (setting under d.02)	Current value		min	–	–	Not adjustable
d.68 Number of unsuccessful ignitions at 1st attempt	Current value		–	–	–	Not adjustable
d.69 Number of unsuccessful ignitions at 2nd attempt	Current value		–	–	–	Not adjustable
d.71 Maximum target heating flow temperature	45	80	°C	1	75	Adjustable
d.75 Maximum cylinder post-heating time	20	90	min	1	45	Adjustable
d.77 Max. cylinder post-heating	–	–	kW	1 → Section "Technical data"	–	Adjustable
d.78 DHW max. flow temperature	50	80	°C	1	–	Adjustable
d.80 Running time in heating mode	Current value		h	–	–	Not adjustable
d.81 Running time in DHW mode	Current value		h	–	–	Not adjustable
d.82 Number of burner ignitions in heating mode	Current value		–	Number of ignitions = Display value x 100	–	Not adjustable
d.83 Number of burner ignitions in DHW mode	Current value		–	Number of ignitions = Display value x 100	–	Not adjustable
d.84 Maintenance in	0	3000	h	Number of hours = Display value x 10	300	Not adjustable
d.85 Increase in the min. output (heating and DHW mode)	–	–	kW	1 → Section "Technical data"	–	Adjustable
d.90 Status of the eBUS room thermostat	Current value		–	off = Not connected on = Connected	–	Not adjustable
d.93 Setting the product code	0	99	–	1	–	Adjustable
d.94 Delete fault list	0	1	–	off = No on = Yes	–	Adjustable
d.95 Software versions	–	–	–	1 = Main PCB 2 = Interface PCB	–	Adjustable
d.96 Reset to factory settings	–	–	–	0 = No 1 = Yes	–	Adjustable
d.128 Heating minimum target value	10	75	°C	1	10	Adjustable
d.129 Domestic hot water minimum target value	35 (combi boiler) 45 (system boiler)	60	°C	1	35	Adjustable

## C Status codes – Overview

Status code	Meaning
<b>Displays in heating mode</b>	
<b>S. 0</b>	Heating mode: No requirement
<b>S.01</b>	Heating mode: Fan prerun
<b>S.02</b>	Heating mode: Pump prerun
<b>S.03</b>	Heating mode: Burner ignition
<b>S.04</b>	Heating mode: Burner on
<b>S.05</b>	Heating mode: Pump/fan overrun
<b>S.06</b>	Heating mode: Fan overrun
<b>S.07</b>	Heating mode: Pump overrun
<b>S.08</b>	Heating mode: Temporary shutdown after heating procedure
<b>Display in domestic hot water mode with cylinder</b>	
<b>S.20</b>	Domestic hot water mode: Requirement
<b>S.21</b>	Domestic hot water mode: Fan prerun
<b>S.22</b>	Domestic hot water mode: Pump prerun
<b>S.23</b>	Domestic hot water mode: Burner ignition
<b>S.24</b>	DHW mode: Burner on
<b>S.25</b>	DHW mode: Pump/fan overrun
<b>S.26</b>	DHW mode: Fan overrun
<b>S.27</b>	DHW mode: Pump overrun
<b>S.28</b>	Domestic hot water mode: Temporary shutdown of the burner
<b>Other displays</b>	
<b>S.30</b>	Room thermostat is blocking heating mode.
<b>S.31</b>	No heating demand: Summer mode, eBUS control, waiting period
<b>S.32</b>	Fan waiting time: Fan speed outside of the tolerance values
<b>S.34</b>	Frost protection active
<b>S.39</b>	Underfloor heating contact open
<b>S.42</b>	Flue non-return flap closed
<b>S.46</b>	Frost protection mode (Comfort): Minimum load
<b>S.53</b>	Product in waiting period/operating block function due to water deficiency (flow/return spread too large)
<b>S.54</b>	Waiting period: Water deficiency in the circuit (flow/return spread too large)
<b>S.88</b>	Product purging active
<b>S.91</b>	Maintenance: Demo mode
<b>S.96</b>	Automatic test programme: Return temperature sensor, heating demands blocked.
<b>S.98</b>	Automatic test programme: Return temperature sensor, heating demands blocked.
<b>S.99</b>	Internal automatic test programmes
<b>S.108</b>	Purging the combustion chamber, fan in operation
<b>S.109</b>	Product's standby mode activated

## D Overview of fault codes

Code	Meaning	Cause
F.00	Flow temperature sensor interruption	NTC plug not plugged in or has come loose, multiple plug on the PCB not plugged in correctly, interruption in cable harness, NTC defective
F.01	Return temperature sensor interruption	NTC plug not plugged in or has come loose, multiple plug on the PCB not plugged in correctly, interruption in cable harness, NTC defective
F.10	Flow temperature sensor short circuit	NTC defective, short circuit in cable harness, cable/housing
F.11	Return temperature sensor short circuit	NTC defective, short circuit in cable harness, cable/housing
F.13	Warm start sensor/cylinder temperature sensor short circuit	NTC defective, short circuit in cable harness, cable/housing
F.22	Safety shutdown: Water deficiency	No or insufficient water in the product, water pressure sensor defective, cable to pump or water pressure sensor loose/not connected/defective
F.23	Safety shutdown: Temperature spread too great	Pump blocked, insufficient pump output, air in product, flow and return NTC connected the wrong way round
F.24	Safety shutdown: Temperature rise too fast	Pump blocked, insufficient pump output, air in product, system pressure too low, non-return valve blocked/incorrectly installed
F.25	Safety shutdown: Flue gas temperature too high	Break in plug connection for optional flue gas safety cut-out (SCO), break in cable harness
F.27	Safety shutdown: Flame simulation	Moisture on the electronics, electronics (flame monitor) defective, gas solenoid valve leaking
F.28	Failure during start-up: Ignition unsuccessful	Gas meter defective or gas pressure switch has triggered, air in gas, gas flow pressure too low, thermal cut-out has triggered, condensate route blocked, incorrect gas injector, incorrect spare gas valve assembly, fault on the gas valve assembly, multiple plug on PCB incorrectly plugged in, break in cable harness, ignition system (ignition transformer, ignition cable, ignition plug, ignition electrode) defective, ionisation flow interrupted (cable, electrode), incorrect earthing of product, electronics defective
F.29	Failure during operation: Re-ignition unsuccessful	Gas supply temporarily stopped, flue gas recirculation, condensate route blocked, defective earthing of product, ignition transformer has spark failure
F.32	Fan fault	Plug on fan not correctly plugged in, multiple plug on PCB not correctly plugged in, break in cable harness, fan blocked, Hall sensor defective, electronics defective
F.49	Fault: eBUS	Short circuit on eBUS, eBUS overload or two power supplies with different polarities on the eBUS
F.61	Fault: Gas valve assembly actuation	<ul style="list-style-type: none"> <li>– Short circuit/short to earth in cable harness for the gas valve assembly</li> <li>– Gas valve assembly defective (coils shorted to earth)</li> <li>– Electronics defective</li> </ul>
F.62	Fault: Gas valve assembly switch-off delay	<ul style="list-style-type: none"> <li>– Delayed shutdown of gas valve assembly</li> <li>– Delayed extinguishing of flame signal</li> <li>– Gas valve assembly leaking</li> <li>– Electronics defective</li> </ul>
F.63	Fault: EEPROM	Electronics defective
F.64	Fault: Electronics/NTC	Flow or return NTC short circuited, electronics defective
F.65	Fault: Electronics temp.	Electronics overheating due to external influences, electronics defective
F.67	Fault: Electronics/flame	Implausible flame signal, electronics defective
F.68	Fault: Unstable flame signal	Air in gas, gas flow pressure too low, incorrect air ratio, condensate route blocked, incorrect gas injector, ionisation flow interruption (cable, electrode), flue gas recirculation, condensate route
F.70	Invalid device specific number (DSN)	If spare parts fitted: Display and PCB replaced at same time and DSN not reset, incorrect or missing output coding resistor
F.71	Fault: Flow temperature sensor	The flow temperature sensor signals a constant value: <ul style="list-style-type: none"> <li>– Flow temperature sensor incorrectly positioned on the flow pipe</li> <li>– Flow temperature sensor defective</li> </ul>
F.72	Flow and/or return temperature sensor fault	Flow/return NTC temperature difference too great → flow and/or return temperature sensor defective
F.73	Water pressure sensor signal in the wrong range (too low)	Interruption/short circuit of water pressure sensor, interruption/short circuit to GND in supply line to water pressure sensor or water pressure sensor defective
F.74	Water pressure sensor signal outside correct range (too high)	Line to water pressure sensor has a short circuit to 5 V/24 V or internal fault in the water pressure sensor

Code	Meaning	Cause
F.75	Fault: No pressure change detection when starting pump	Water pressure sensor and/or pump defective, air in the heating installation, insufficient water in the product; check adjustable bypass, connect external expansion vessel to the return
F.76	Overheating protection on primary heat exchanger has responded	Cable or cable connections for safety fuse in primary heat exchanger or primary heat exchanger defective
F.77	Fault: Flue non-return flap/condensate pump	No response from flue non-return flap or condensate pump defective
F.83	Fault: Flow and/or return temperature sensor temperature change	When the burner starts, the temperature change registered at the flow and/or return temperature sensor is non-existent or too small. <ul style="list-style-type: none"> <li>- Insufficient water in product</li> <li>- Flow or return temperature sensor not in correct position at pipe</li> </ul>
F.84	Fault: Temperature difference at the flow and return temperature sensors	The temperature sensors return implausible values (temperature difference < -6 K). <ul style="list-style-type: none"> <li>- Flow and return temperature sensors are inverted</li> <li>- Flow and/or return temperature sensors installed incorrectly</li> </ul>
F.85	Fault: Flow and return temperature sensors incorrectly installed	The flow and/or return temperature sensors have been installed on the same pipe/incorrect pipe
F.87	Ignition transformer not connected	Ignition transformer plug not plugged in or has come loose, multiple plug on the PCB not plugged in correctly, interruption in cable harness, electronics defective
F.88	Gas valve not connected	Gas valve plug not plugged in or has come loose, multiple plug on the PCB not plugged in correctly, interruption in cable harness, electronics defective
F.89	Incorrect pump detected	Unsuitable pump connected, PWM plug not plugged in or has come loose, multiple plug on the PCB not plugged in correctly, interruption in cable harness, electronics defective
F.97	Fault: Main PCB self-test failed	Main PCB defective
con	No communication with the PCB	Communication fault between the display and the PCB in the electronics box

## E Wiring diagram

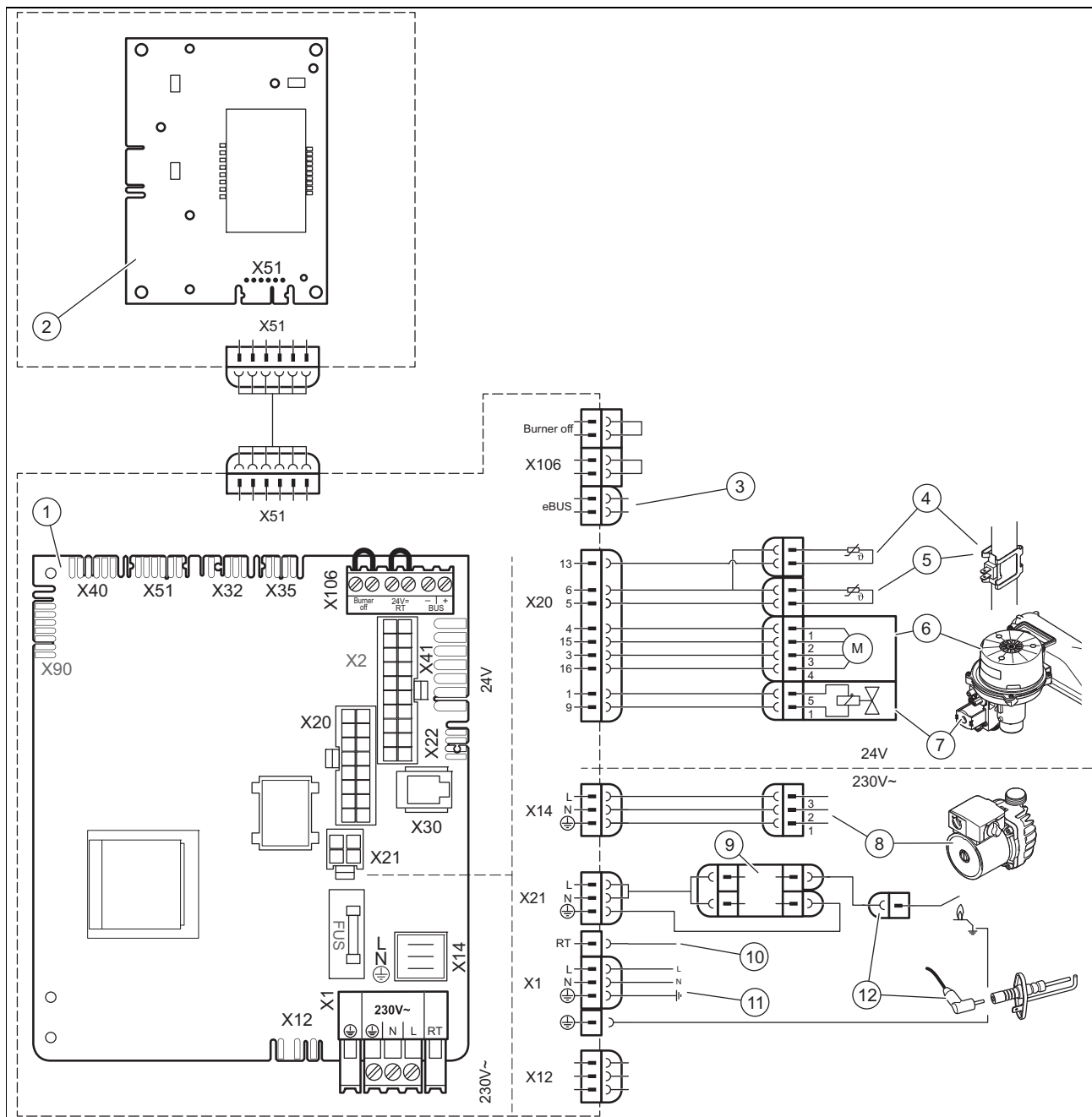

- |   |  |    |  |
|---|--|----|--|
| 1 | Main PCB                                 | 7  | Gas valve assembly                                 |
| 2 | Interface PCB                            | 8  | Heating pump                                       |
| 3 | Control system                           | 9  | Monitoring electrode                               |
| 4 | Temperature sensor on the heating flow   | 10 | Room thermostat                                    |
| 5 | Temperature sensor on the heating return | 11 | Main power supply and connection for 230 V control |
| 6 | Fan                                      | 12 | Ignition electrode                                 |

## F Wiring diagram, 30 kW

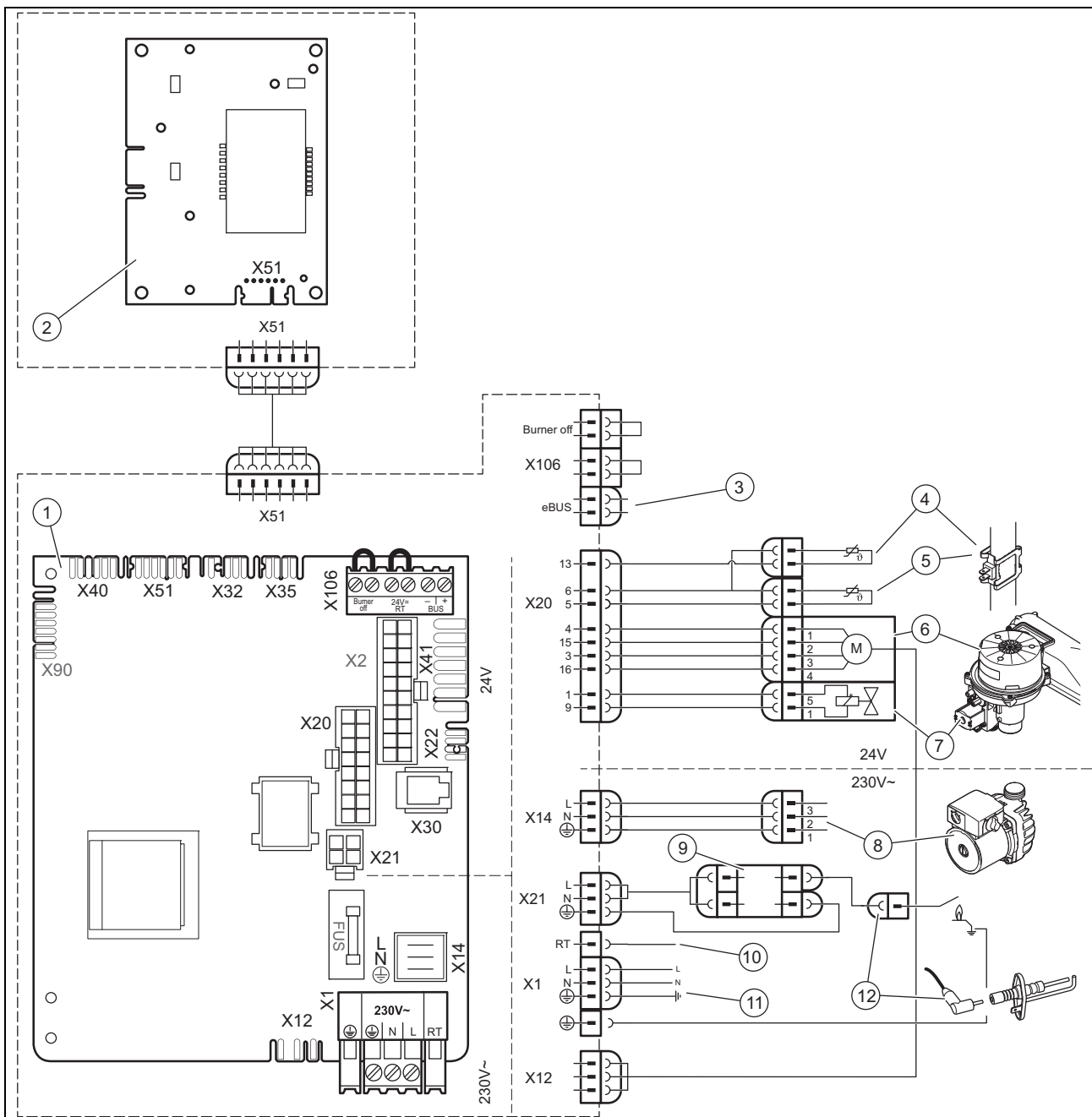

- |   |  |    |  |
|---|--|----|--|
| 1 | Main PCB                                 | 7  | Gas valve assembly                                 |
| 2 | Interface PCB                            | 8  | Heating pump                                       |
| 3 | Control system                           | 9  | Monitoring electrode                               |
| 4 | Temperature sensor on the heating flow   | 10 | Room thermostat                                    |
| 5 | Temperature sensor on the heating return | 11 | Main power supply and connection for 230 V control |
| 6 | Fan                                      | 12 | Ignition electrode                                 |

## **Benchmark Commissioning & Warranty Validation Service Record**

It is a requirement that the boiler is installed and commissioned to the manufacturers' instructions and the data fields on the commissioning checklist completed in full.

To instigate the boiler warranty the boiler needs to be registered with the manufacturer within one month of the installation. The warranty rests with the end-user (consumer), and they should be made aware it is ultimately their responsibility to register with the manufacturer, within the allotted time period.

It is essential that the boiler is serviced in line with the manufacturers' recommendations, at least annually. This must be carried out by a competent Gas Safe registered engineer. The service details should be recorded on the Benchmark Service and Interim Boiler Work Record and left with the householder. Failure to comply with the manufacturers' servicing instructions and requirements will invalidate the warranty.



**[www.hhic.co.uk](http://www.hhic.co.uk)**

**This Commissioning Checklist is to be completed in full by the competent person who commissioned the boiler as a means of demonstrating compliance with the appropriate Building Regulations and then handed to the customer to keep for future reference.**

Failure to install and commission according to the manufacturers' instructions and complete this Benchmark Commissioning Checklist will invalidate the warranty. This does not affect the customer's statutory rights.

\* All installations in England and Wales must be notified to Local Authority Building Control (LABC) either directly or through a Competent Persons Scheme. A Building Regulations Compliance Certificate will then be issued to the customer.

© Heating and Hotwater Industry Council (HHIC)



[www.centralheating.co.uk](http://www.centralheating.co.uk)

## GAS BOILER SYSTEM COMMISSIONING CHECKLIST & WARRANTY VALIDATION RECORD

Address:											
Boiler make and model:											
Boiler serial number:											
Commissioned by (PRINT NAME):						Gas Safe registration number:					
Company name:						Telephone number:					
Company email:						Company address:					
										Commissioning date:	
Heating and hot water system complies with the appropriate Building Regulations?											Yes
Optional: Building Regulations Notification Number (if applicable):											
Time, temperature control and boiler interlock provided for central heating and hot water											Yes
Boiler Plus requirements (tick the appropriate box(s))											
Boiler Plus option chosen for combination boiler in ENGLAND						Weather compensation			Smart thermostat with automisation and optimisation		
						Load compensation			Flue Gas Heat Recovery		
Time and temperature control to hot water			Cylinder thermostat and programmer/timer						Combination boiler		
Zone valves		pre-existing		Fitted		Not required					
Thermostatic radiator valves		pre-existing		Fitted		Not required					
Automatic bypass to system		pre-existing		Fitted		Not required					
Underfloor heating		pre-existing		Fitted		Not required					
Water quality											
The system has been flushed, cleaned and a suitable inhibitor applied upon final fill, in accordance with BS7593 and boiler manufacturers' instructions											Yes
What system cleaner was used?						Brand:			Product:		
What inhibitor was used?						Brand:			Product:		
Primary water system filter		pre-existing		Fitted		Not required					
CENTRAL HEATING MODE measure and record (as appropriate)											
Gas rate (for combination boilers complete DHW mode gas rate)						m <sup>3</sup> /hr		or		ft <sup>3</sup> /hr	
Central heating output left at factory settings?						Yes		No			
If no, what is the maximum central heating output selected? kW											
Dynamic gas inlet pressure mbar											
Central heating flow temperature °C											
Central heating return temperature °C											
System correctly balanced/rebalanced?											Yes
COMBINATION BOILERS ONLY											
Is the installation in a hard water area (above 200ppm)?						Yes		No			
Water scale reducer/softener		pre-existing		Fitted		Not required					
What type of scale reducer/softener has been fitted?						Brand:			Product:		
Water meter fitted?						Yes		No			
If yes- DHW expansion vessel		pre-existing		Fitted		Not required					
Pressure reducing valve		pre-existing		Fitted		Not required					
DOMESTIC HOT WATER MODE Measure and record											
Gas rate						m <sup>3</sup> /hr		or		ft <sup>3</sup> /hr	
Dynamic gas inlet pressure at maximum rate mbar											
Cold water inlet temperature °C											
Hot water has been checked at all outlets						Yes		Temperature		°C	
CONDENSATE DISPOSAL											
The condensate drain has been installed in accordance with the manufacturers' instructions and/or BS5546/BS6798											Yes
Point of termination						Internal		External (only where internal termination impractical)			
Method of disposal						Gravity		Pumped			
ALL INSTALLATIONS											
Record the following		At max rate:		CO ppm		CO <sub>2</sub> %		CO/CO <sub>2</sub> Ratio			
		At min rate (where possible)		CO ppm		CO <sub>2</sub> %		CO/CO <sub>2</sub> Ratio			
Where possible, has a flue integrity check been undertaken in accordance with manufacturers' instructions, and readings are correct?											Yes
The operation of the boiler and system controls have been demonstrated to and understood by the customer											Yes
The manufacturers' literature, including Benchmark Checklist and Service Record, has been explained and left with the customer											Yes
Commissioning Engineer's signature											
Customer's signature (To confirm satisfactory demonstration and receipt of manufacturers' literature)											

\* All installations in England and Wales must be notified to Local Authority Building Control (LABC) either directly or through a Competent Persons Scheme. A Building Regulations Compliance Certificate will then be issued to the customer.

© Heating and Hotwater Industry Council (HHIC)



www.centralheating.co.uk

## SERVICE & INTERIM BOILER WORK RECORD

It is recommended that your boiler and heating system are regularly serviced and maintained, in line with manufacturers' instructions, and that the appropriate service / interim work record is completed.

### Service provider

When completing a service record (as below), please ensure you have carried out the service as described in the manufacturers' instructions. Always use the manufacturers' specified spare parts.

SERVICE/INTERIM WORK ON BOILER <small>delete as appropriate</small>					Date:
Engineer name:		Company name:			
Telephone N°:		Gas Safe registration N°:			
Max rate	CO	ppm	CO <sub>2</sub>	%	CO/CO <sub>2</sub>
Min rate	CO	ppm	CO <sub>2</sub>	%	CO/CO <sub>2</sub>
Where possible, has a flue integrity check been undertaken in accordance with manufacturers' instructions, and readings are correct?*					yes
Gas rate:	m <sup>3</sup> /h	OR	ft <sup>3</sup> /h		
Were parts fitted? <small>delete as appropriate</small>		Yes	No		
Parts fitted:					
System inhibitor concentration has been checked and appropriate action taken, in accordance with BS 7593 and boiler manufacturers' instructions. *					yes n/a
Comments:					
Signature:					

\*A System inhibitor efficacy test is required on every annual service in accordance with the manufacturers' instructions and BS 7593. It is only acceptable to not have undertaken this if the service engineers attendance visit was in between annual services to attend a non-water facing component.

SERVICE/INTERIM WORK ON BOILER <small>delete as appropriate</small>					Date:
Engineer name:		Company name:			
Telephone N°:		Gas Safe registration N°:			
Max rate	CO	ppm	CO <sub>2</sub>	%	CO/CO <sub>2</sub>
Min rate	CO	ppm	CO <sub>2</sub>	%	CO/CO <sub>2</sub>
Where possible, has a flue integrity check been undertaken in accordance with manufacturers' instructions, and readings are correct?*					yes
Gas rate:	m <sup>3</sup> /h	OR	ft <sup>3</sup> /h		
Were parts fitted? <small>delete as appropriate</small>		Yes	No		
Parts fitted:					
System inhibitor concentration has been checked and appropriate action taken, in accordance with BS 7593 and boiler manufacturers' instructions. *					yes n/a
Comments:					
Signature:					

\*A System inhibitor efficacy test is required on every annual service in accordance with the manufacturers' instructions and BS 7593. It is only acceptable to not have undertaken this if the service engineers attendance visit was in between annual services to attend a non-water facing component.

SERVICE/INTERIM WORK ON BOILER <small>delete as appropriate</small>					Date:
Engineer name:		Company name:			
Telephone N°:		Gas Safe registration N°:			
Max rate	CO	ppm	CO <sub>2</sub>	%	CO/CO <sub>2</sub>
Min rate	CO	ppm	CO <sub>2</sub>	%	CO/CO <sub>2</sub>
Where possible, has a flue integrity check been undertaken in accordance with manufacturers' instructions, and readings are correct?*					yes
Gas rate:	m <sup>3</sup> /h	OR	ft <sup>3</sup> /h		
Were parts fitted? <small>delete as appropriate</small>		Yes	No		
Parts fitted:					
System inhibitor concentration has been checked and appropriate action taken, in accordance with BS 7593 and boiler manufacturers' instructions. *					yes n/a
Comments:					
Signature:					

\*A System inhibitor efficacy test is required on every annual service in accordance with the manufacturers' instructions and BS 7593. It is only acceptable to not have undertaken this if the service engineers attendance visit was in between annual services to attend a non-water facing component.

SERVICE/INTERIM WORK ON BOILER <small>delete as appropriate</small>					Date:
Engineer name:		Company name:			
Telephone N°:		Gas Safe registration N°:			
Max rate	CO	ppm	CO <sub>2</sub>	%	CO/CO <sub>2</sub>
Min rate	CO	ppm	CO <sub>2</sub>	%	CO/CO <sub>2</sub>
Where possible, has a flue integrity check been undertaken in accordance with manufacturers' instructions, and readings are correct?*					yes
Gas rate:	m <sup>3</sup> /h	OR	ft <sup>3</sup> /h		
Were parts fitted? <small>delete as appropriate</small>		Yes	No		
Parts fitted:					
System inhibitor concentration has been checked and appropriate action taken, in accordance with BS 7593 and boiler manufacturers' instructions. *					yes n/a
Comments:					
Signature:					

\*A System inhibitor efficacy test is required on every annual service in accordance with the manufacturers' instructions and BS 7593. It is only acceptable to not have undertaken this if the service engineers attendance visit was in between annual services to attend a non-water facing component.

SERVICE/INTERIM WORK ON BOILER <small>delete as appropriate</small>					Date:
Engineer name:		Company name:			
Telephone N°:		Gas Safe registration N°:			
Max rate	CO	ppm	CO <sub>2</sub>	%	CO/CO <sub>2</sub>
Min rate	CO	ppm	CO <sub>2</sub>	%	CO/CO <sub>2</sub>
Where possible, has a flue integrity check been undertaken in accordance with manufacturers' instructions, and readings are correct?*					yes
Gas rate:	m <sup>3</sup> /h	OR	ft <sup>3</sup> /h		
Were parts fitted? <small>delete as appropriate</small>		Yes	No		
Parts fitted:					
System inhibitor concentration has been checked and appropriate action taken, in accordance with BS 7593 and boiler manufacturers' instructions. *					yes n/a
Comments:					
Signature:					

\*A System inhibitor efficacy test is required on every annual service in accordance with the manufacturers' instructions and BS 7593. It is only acceptable to not have undertaken this if the service engineers attendance visit was in between annual services to attend a non-water facing component.

SERVICE/INTERIM WORK ON BOILER <small>delete as appropriate</small>					Date:
Engineer name:		Company name:			
Telephone N°:		Gas Safe registration N°:			
Max rate	CO	ppm	CO <sub>2</sub>	%	CO/CO <sub>2</sub>
Min rate	CO	ppm	CO <sub>2</sub>	%	CO/CO <sub>2</sub>
Where possible, has a flue integrity check been undertaken in accordance with manufacturers' instructions, and readings are correct?*					yes
Gas rate:	m <sup>3</sup> /h	OR	ft <sup>3</sup> /h		
Were parts fitted? <small>delete as appropriate</small>		Yes	No		
Parts fitted:					
System inhibitor concentration has been checked and appropriate action taken, in accordance with BS 7593 and boiler manufacturers' instructions. *					yes n/a
Comments:					
Signature:					

\*A System inhibitor efficacy test is required on every annual service in accordance with the manufacturers' instructions and BS 7593. It is only acceptable to not have undertaken this if the service engineers attendance visit was in between annual services to attend a non-water facing component.

\* All installations in England and Wales must be notified to Local Authority Building Control (LABC) either directly or through a Competent Persons Scheme. A Building Regulations Compliance Certificate will then be issued to the customer.

© Heating and Hotwater Industry Council (HHIC)



www.centralheating.co.uk

# SERVICE & INTERIM BOILER WORK RECORD

It is recommended that your boiler and heating system are regularly serviced and maintained, in line with manufacturers' instructions, and that the appropriate service / interim work record is completed.

## Service provider

When completing a service record (as below), please ensure you have carried out the service as described in the manufacturers' instructions. Always use the manufacturers' specified spare parts.

<b>SERVICE/INTERIM WORK ON BOILER</b> <small>delete as appropriate</small>					Date:	
Engineer name:		Company name:				
Telephone N°:		Gas Safe registration N°:				
Max rate	CO	ppm	CO <sub>2</sub>	%	CO/CO <sub>2</sub>	
Min rate	CO	ppm	CO <sub>2</sub>	%	CO/CO <sub>2</sub>	
Where possible, has a flue integrity check been undertaken in accordance with manufacturers' instructions, and readings are correct?"					yes	
Gas rate:	m <sup>3</sup> /h	OR	ft <sup>3</sup> /h			
Were parts fitted? <small>delete as appropriate</small>		Yes	No			
Parts fitted:						
System inhibitor concentration has been checked and appropriate action taken, in accordance with BS 7593 and boiler manufacturers' instructions. *					yes	n/a
Comments:						
Signature:						

\*A System inhibitor efficacy test is required on every annual service in accordance with the manufacturers' instructions and BS 7593. It is only acceptable to not have undertaken this if the service engineers attendance visit was in between annual services to attend a non-water facing component.

<b>SERVICE/INTERIM WORK ON BOILER</b> <small>delete as appropriate</small>					Date:	
Engineer name:		Company name:				
Telephone N°:		Gas Safe registration N°:				
Max rate	CO	ppm	CO <sub>2</sub>	%	CO/CO <sub>2</sub>	
Min rate	CO	ppm	CO <sub>2</sub>	%	CO/CO <sub>2</sub>	
Where possible, has a flue integrity check been undertaken in accordance with manufacturers' instructions, and readings are correct?"					yes	
Gas rate:	m <sup>3</sup> /h	OR	ft <sup>3</sup> /h			
Were parts fitted? <small>delete as appropriate</small>		Yes	No			
Parts fitted:						
System inhibitor concentration has been checked and appropriate action taken, in accordance with BS 7593 and boiler manufacturers' instructions. *					yes	n/a
Comments:						
Signature:						

\*A System inhibitor efficacy test is required on every annual service in accordance with the manufacturers' instructions and BS 7593. It is only acceptable to not have undertaken this if the service engineers attendance visit was in between annual services to attend a non-water facing component.

<b>SERVICE/INTERIM WORK ON BOILER</b> <small>delete as appropriate</small>					Date:	
Engineer name:		Company name:				
Telephone N°:		Gas Safe registration N°:				
Max rate	CO	ppm	CO <sub>2</sub>	%	CO/CO <sub>2</sub>	
Min rate	CO	ppm	CO <sub>2</sub>	%	CO/CO <sub>2</sub>	
Where possible, has a flue integrity check been undertaken in accordance with manufacturers' instructions, and readings are correct?"					yes	
Gas rate:	m <sup>3</sup> /h	OR	ft <sup>3</sup> /h			
Were parts fitted? <small>delete as appropriate</small>		Yes	No			
Parts fitted:						
System inhibitor concentration has been checked and appropriate action taken, in accordance with BS 7593 and boiler manufacturers' instructions. *					yes	n/a
Comments:						
Signature:						

\*A System inhibitor efficacy test is required on every annual service in accordance with the manufacturers' instructions and BS 7593. It is only acceptable to not have undertaken this if the service engineers attendance visit was in between annual services to attend a non-water facing component.

<b>SERVICE/INTERIM WORK ON BOILER</b> <small>delete as appropriate</small>					Date:	
Engineer name:		Company name:				
Telephone N°:		Gas Safe registration N°:				
Max rate	CO	ppm	CO <sub>2</sub>	%	CO/CO <sub>2</sub>	
Min rate	CO	ppm	CO <sub>2</sub>	%	CO/CO <sub>2</sub>	
Where possible, has a flue integrity check been undertaken in accordance with manufacturers' instructions, and readings are correct?"					yes	
Gas rate:	m <sup>3</sup> /h	OR	ft <sup>3</sup> /h			
Were parts fitted? <small>delete as appropriate</small>		Yes	No			
Parts fitted:						
System inhibitor concentration has been checked and appropriate action taken, in accordance with BS 7593 and boiler manufacturers' instructions. *					yes	n/a
Comments:						
Signature:						

\*A System inhibitor efficacy test is required on every annual service in accordance with the manufacturers' instructions and BS 7593. It is only acceptable to not have undertaken this if the service engineers attendance visit was in between annual services to attend a non-water facing component.

<b>SERVICE/INTERIM WORK ON BOILER</b> <small>delete as appropriate</small>					Date:	
Engineer name:		Company name:				
Telephone N°:		Gas Safe registration N°:				
Max rate	CO	ppm	CO <sub>2</sub>	%	CO/CO <sub>2</sub>	
Min rate	CO	ppm	CO <sub>2</sub>	%	CO/CO <sub>2</sub>	
Where possible, has a flue integrity check been undertaken in accordance with manufacturers' instructions, and readings are correct?"					yes	
Gas rate:	m <sup>3</sup> /h	OR	ft <sup>3</sup> /h			
Were parts fitted? <small>delete as appropriate</small>		Yes	No			
Parts fitted:						
System inhibitor concentration has been checked and appropriate action taken, in accordance with BS 7593 and boiler manufacturers' instructions. *					yes	n/a
Comments:						
Signature:						

\*A System inhibitor efficacy test is required on every annual service in accordance with the manufacturers' instructions and BS 7593. It is only acceptable to not have undertaken this if the service engineers attendance visit was in between annual services to attend a non-water facing component.

<b>SERVICE/INTERIM WORK ON BOILER</b> <small>delete as appropriate</small>					Date:	
Engineer name:		Company name:				
Telephone N°:		Gas Safe registration N°:				
Max rate	CO	ppm	CO <sub>2</sub>	%	CO/CO <sub>2</sub>	
Min rate	CO	ppm	CO <sub>2</sub>	%	CO/CO <sub>2</sub>	
Where possible, has a flue integrity check been undertaken in accordance with manufacturers' instructions, and readings are correct?"					yes	
Gas rate:	m <sup>3</sup> /h	OR	ft <sup>3</sup> /h			
Were parts fitted? <small>delete as appropriate</small>		Yes	No			
Parts fitted:						
System inhibitor concentration has been checked and appropriate action taken, in accordance with BS 7593 and boiler manufacturers' instructions. *					yes	n/a
Comments:						
Signature:						

\*A System inhibitor efficacy test is required on every annual service in accordance with the manufacturers' instructions and BS 7593. It is only acceptable to not have undertaken this if the service engineers attendance visit was in between annual services to attend a non-water facing component.

\* All installations in England and Wales must be notified to Local Authority Building Control (LABC) either directly or through a Competent Persons Scheme. A Building Regulations Compliance Certificate will then be issued to the customer.

© Heating and Hotwater Industry Council (HHIC)



www.centralheating.co.uk

# H Commissioning Flow Chart

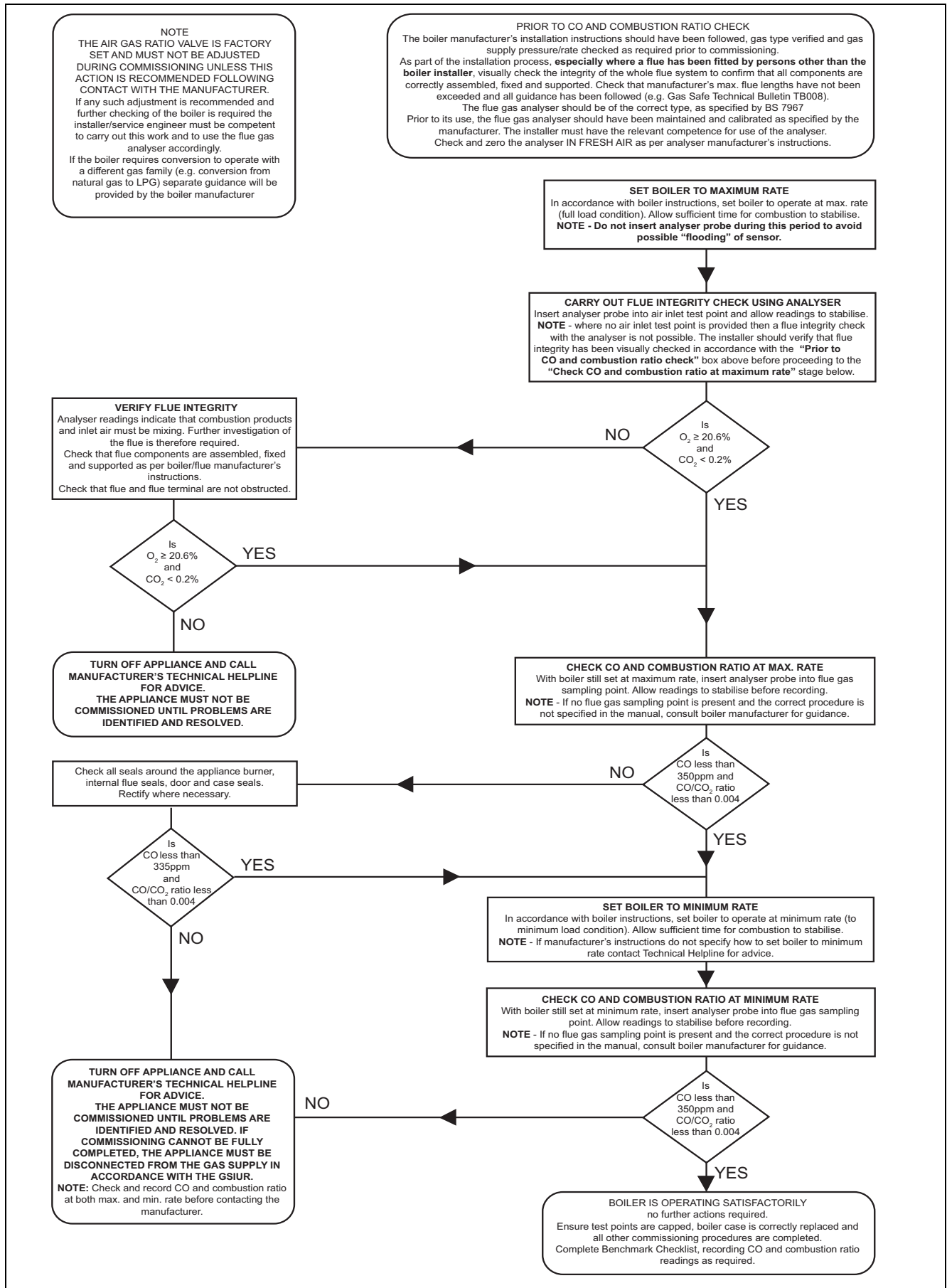

# Index

<b>A</b>	
Air intake pipe, removing .....	32
Air/flue pipe, horizontal wall duct .....	17
Air/flue pipe, installing .....	23
Air/flue pipe, type C13 .....	17
Air/flue pipe, type C33 .....	17
Air/flue pipe, vertical roof duct .....	17
Article number .....	11
Assemblies .....	12
<b>B</b>	
Burner anti-cycling time .....	30
Burner anti-cycling time, resetting .....	31
Burner anti-cycling time, setting .....	30
Burner, checking .....	33
Burner, removing .....	32
Burner, replacing .....	35
<b>C</b>	
Cable duct .....	23
CE marking .....	11
Check programmes .....	26
CO <sub>2</sub> content, checking .....	29, 32
CO <sub>2</sub> content, setting .....	32
Condensate discharge pipe .....	21
Condensate trap, cleaning .....	34
Condensate trap, filling .....	28
Control .....	24
<b>D</b>	
Data plate .....	11
Decommissioning .....	36
Design .....	12
Dimensions .....	13
Display and setting options .....	26
Disposal, packaging .....	36
Disposing of the packaging .....	36
Documents .....	11
<b>E</b>	
Electrical installation .....	23
<b>F</b>	
Factory settings, restoring .....	34
Fault codes .....	34, 42
Fault memory, calling up .....	34
Fault memory, deleting .....	34
Fault messages .....	34
Filling .....	28
Flue gas recirculation, checking .....	28
Flue pipe, removing .....	32
Front casing, installing .....	18
Front casing, removing .....	18
Frost protection .....	12
Functional elements .....	12
<b>G</b>	
Gas connection pressure, checking .....	29
Gas connection, establishing .....	21
Gas Council Number .....	11
Gas flow rate .....	28
Gas group, checking .....	20
Gas setting .....	28
Gas-air mixture, installing .....	34
Gas-air mixture, removing .....	32
Gas-air mixture, replacing .....	35
Guarantee and Customer Service .....	6
<b>H</b>	
Handing over to the end user .....	31
Heat exchanger, cleaning .....	33
Heat exchanger, replacing .....	35
Heating flow, connecting .....	20
Heating installation, filling .....	28
Heating mode, checking .....	30
Heating pump, connecting .....	24
Heating pump, installing .....	19
Heating return, connecting .....	20
Heating system, open .....	19
Heating water supply, open heating system .....	19
<b>I</b>	
Ignition electrode, checking .....	33
Initial start-up, carrying out .....	27
Inspection work .....	32
Inspection work, completing .....	34
Installation site .....	13
Installation, preparations .....	19
Installer level .....	26
Installer level, calling up .....	26
Intended use .....	3
<b>K</b>	
Kammerbelüftung .....	14
<b>L</b>	
Leak-tightness .....	30, 36
<b>M</b>	
Maintenance work .....	32
Maintenance work, completing .....	34
Minimum clearance .....	14
Mounting template .....	17
<b>O</b>	
Operating concept .....	26
Overheating protection .....	12
<b>P</b>	
PCB, replacing .....	36
Power supply .....	24
Power supply, establishing .....	24
Product, decommissioning .....	36
Product, mounting .....	17
Product, switching on .....	28
<b>R</b>	
Regulations .....	5
Repair work, preparing .....	34
<b>S</b>	
Safety devices .....	12
Scope of delivery .....	13
Serial number .....	11
Side section, installing .....	18
Side section, removing .....	18
Spare parts .....	35
Status codes .....	26
Switching on .....	28
<b>T</b>	
Technical data .....	7
Treating the heating water .....	27
<b>U</b>	
User interface PCB, replacing .....	36
<b>V</b>	
Validity of the instructions .....	11
<b>W</b>	
Weight .....	17

**Supplier**

**Vaillant Ltd.**

Nottingham Road ■ Belper ■ Derbyshire ■ DE56 1JT

Telephone 0330 100 3461

info@vaillant.co.uk ■ www.vaillant.co.uk



0020230535\_09

**Publisher/manufacture**

**Vaillant GmbH**

Berghauser Str. 40 ■ D-42859 Remscheid

Tel. +492191 18 0 ■ Fax +492191 18 2810

info@vaillant.de ■ www.vaillant.de

© These instructions, or parts thereof, are protected by copyright and may be reproduced or distributed only with the manufacturer's written consent.

Subject to technical modifications.