

Heating Hot water Renewables

Specification range from Vaillant





| | |
|--|----|
| About Vaillant..... | 4 |
| Setting the standards since 1874..... | 5 |
| Our specification partners..... | 6 |
| ecoFIT sustain boiler range..... | 8 |
| ecoTEC sustain boiler range..... | 12 |
| ecoTEC plus combination and system boiler range..... | 14 |
| What are heat pumps | 18 |
| aroTHERM plus | 20 |
| aroTHERM split..... | 22 |
| uniTOWER | 24 |
| flexoTHERM | 26 |
| aroSTOR | 28 |
| uniSTOR cylinders | 30 |
| uniSTOR accessories | 35 |
| Hybrid systems | 36 |



| | |
|--|----|
| Low carbon solutions from Vaillant..... | 37 |
| Controls..... | 38 |
| Vaillant flues and accessories..... | 47 |
| Why choose Vaillant for your specification?..... | 52 |
| Service and spares support..... | 53 |
| Vaillant design services..... | 54 |
| myVAILLANT Pro Service..... | 55 |
| API integration | 56 |
| Industry leading training | 57 |
| Our locations | 58 |
| Article numbers | 59 |

About Vaillant



The Vaillant Group

Vaillant UK is proud to be part of the worldwide heating and hot water corporation Vaillant Group, a family-owned business that was founded by Johann Vaillant in his workshop in Remscheid, Germany in 1874.

Over 150 years ago, Johann patented a new closed-system gas-fired bathroom boiler which was the first heating product manufactured by Vaillant. Through the years, Vaillant's technical innovations have continued. We launched a central heating boiler in 1924 which was marketed alongside the classic gas-fired water heaters. It was the beginning of central heating as we know it today. And, in 1967 'Combi Geyser' was launched which combined central heating and hot water supply for the first time ever.

Since these revolutionary inventions, Vaillant has continued to drive the evolution of heating technologies. In 2020, Vaillant launched the first air source heat pump using R290 refrigerant, the game-changing aroTHERM plus. At Vaillant, we consistently create new cutting-edge products, while always striving to put our customers first. Our continued support in the gas boiler market includes the next generation ecoTEC plus, which is designed for ease of installation, and incorporates digital technology to ensure maximum efficiency for the end user.

Today, Vaillant is still setting the standard in the heating industry, focused on delivering full heating system solutions that will stand the test of time, whilst supporting installers, specifiers and commercial partners for life. Through developing highly efficient heating appliances, digital heating solutions and providing excellent training offerings that are truly crafted with our customers' needs at heart.

Setting the standards since 1874

Manufacturing at its finest

By choosing our heating appliances, you will get an unwavering commitment to deliver the high standard of products and services that you expect from Vaillant.

In 2025, we opened our second manufacturing plant close to our Belper headquarters in Derbyshire to support the growing heat pump market. Our continuous investment in the UK not only supports the local economy but reinforces our commitment to developing low carbon technology.

Our two manufacturing sites have state-of-the-art facilities that produce our market leading products and we are proud to have been awarded the RoSPA Gold Award for world-class health and safety management systems every year since 2016 at our Belper site. Vaillant has exceptionally high standards in manufacturing to ensure we make outstanding, reliable products that meet ISO 9001, 18001 and 14000.



Our specification partners

Supplying contract boilers for over 40 years

Vaillant's large product portfolio means we have an efficient, cost-effective and future-ready solution for every specification. We work closely with our customers, delivering best-in-class pre- and post-installation support. Here's what they have to say:



"Vaillant have provided our tenants with an improved product and service. We are installing more new Vaillant boilers every year. Reliable product and service to support makes my life a lot easier."

Howard Worwood,
Gas Production Supervisor, Severn Vale Housing



"Curo Group specify Vaillant products as our central heating boiler of choice due to the unrivalled quality of the product."

Dean Roberts,
Gas Safety Manager, Curo Group



"We moved from a rival manufacturer to Vaillant over 15 years ago and have never looked back. The quality, performance, value and international leading name, makes the specification of Vaillant boilers a must for us. The sales and support back up are first rate. The engineering, sustainability support and synergies with the renewable elements fit really well with our high level of quality specification and green ethos. The controls available smash through SAP and Part L, giving us savings opportunities in other fabric areas."

Scott Leather,
Erris Homes



"Wandsworth Borough Council have been installing Vaillant boilers for a number of years. Vaillant are our preferred boiler manufacturer due to the fantastic efficiency levels, long lifespan, high performance and great controllability of their products."

Peter Hedges,
Heating Manager,



"From the outset, we have been impressed with Vaillant's exceptional level of innovation, combined with its ability to work to deadlines, product knowledge, industry awareness and ability to deliver projects on time and to agreed budgets. From the initial tender stage, through to customer service on occupied properties, Vaillant has always adopted a professional and methodical approach and updated us regularly on its progress."

Andy Startin,
Wheeldon Homes



"The Acis Group have been successfully using Vaillant for years. We specified them on the promise of quality and reduced life-cycle costs. Our repairs section are gradually benefiting from this decision."

James Hamilton,
Project Manager, Acis Group

Be Green

"We wanted to create an estate of energy-efficient homes that could showcase how renewables can reliably deliver lower energy consumption, reduced energy costs and minimal environmental impact. Using Vaillant's flexoTHERM ground source heat pump, we know we have utilised the latest technology alongside additional sustainable technologies incorporated into the new homes. The heat pump effectively provides the energy needed for heating and domestic hot water, but does so in an environmentally -friendly way.

"We believe such renewable solutions for homes are the way forward. Vaillant's extensive experience and expertise when it comes to such technologies, as well as their outstanding levels of service support, made them an ideal partner on this project.

"The homeowners at the developments will enjoy comfortable, warm and highly efficient homes, whilst benefitting from reduced energy bills."

Garry Woods,
Be Green Systems



"The best thing about Vaillant for us is the service. They always go the extra mile to make sure we've got everything we need to make our customers happy. You just can't put a value on that level of service.

"I've never known a supplier that offers us training for the products - and knows enough about our business to recommend precisely the right model that's going to deliver the highest performance and maximum efficiency. I've nothing but praise for Vaillant and the way they do business."

Marco Dimuccio,
Wynyard Homes



THAKEHAM
HOMES

"Thakeham is proud of its partnership with Vaillant Group UK. Having worked closely with Vaillant Group UK to develop a boiler specification that was cost efficient, beneficial for SAP calculations and worked with all standard house types.

"Thakeham is excited to continue this relationship and produce further successful results on future projects."

Adam Eaton,
Thakeham Group



"Having used other systems, I decided to move to Vaillant for this type of renewable solution because the company offers a broad product range, and access to invaluable technical resources, to help with the system design and commissioning.

"The 15kW aroTHERM heat pump was the ideal solution for the care homes we were constructing. With no mains gas, we needed to think of an alternative energy source and we are delighted with the sustainability, reliability and running cost benefits that aroTHERM provides. In addition, attending the training courses on offer at Vaillant's Centre of Excellence has been invaluable for my team as we learn more about the system, its capabilities and its best use."

John Ryan,
John Ryan Developments Ltd.

ecoFIT sustain

Combination, system and open vent boiler range



Overview

The ecoFIT sustain boiler range is available in a wide range of outputs in combination, system and open vent models. The sustain range is ErP A rated and is designed specifically for the specification market.

The range features a high quality automotive-grade aluminium heat exchanger, making it lightweight and easy to install. The use of aluminium means it has a high SAP rating and it is compliant with the latest building regulations.

Features & benefits



Cupboard fit

Compact size with flexibility of siting, including the option for cupboard fit.



High SAP performance

Highly efficient and economical to run - up to an 89.3% efficiency rating (SAP 2009).



Aluminium heat exchanger includes patented 4-sided cooling

Increases efficiency and reduces stress to minimise the cost of maintenance over the life of the product.



Patented condensate trap

Easy install with a safety back-up.



Flexibility with choice of rear or top flue

Options for 60/100 direct rear flue from the back of the boiler. Additional options of 60/100 top horizontal or vertical flueing up to 10m or 80/125 top horizontal or vertical flueing up to 25m.



Fully modulating low NOx burner and fan

NOx class 6 as low as 37mg/kWh and modulation of 1:5.



Grundfos high-efficiency pump

The combination and system models feature a modulating high-torque pump that uses low energy to deliver a balanced output to meet the boiler demand.

* ecoFIT sustain 830 and 835 only.



Technical data

ecoFIT sustain combination boiler 25, 30 and 35kW

Clearances:

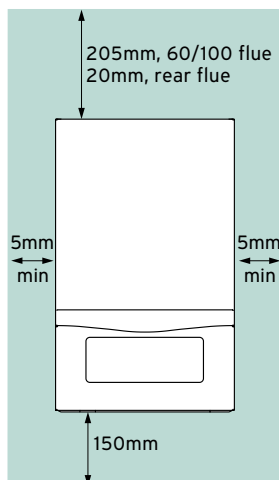

Dimensions:

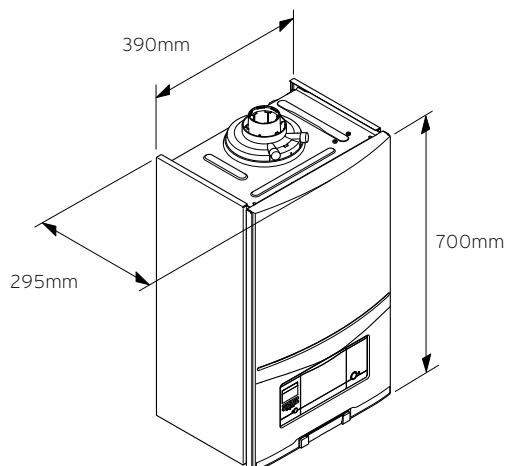

ecoFIT sustain system boiler 15, 18 and 30kW

Clearances:

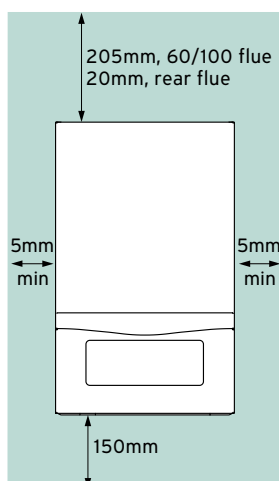

Dimensions:

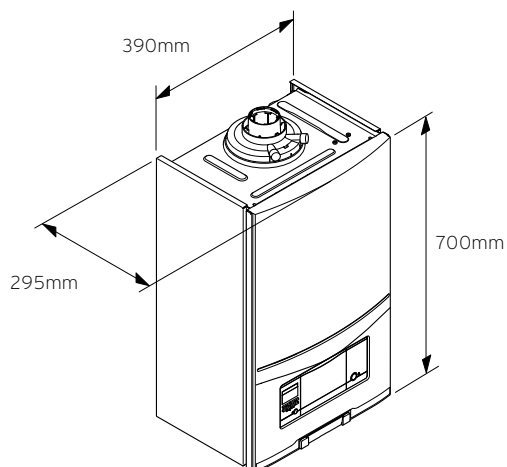

ecoFIT sustain open vent boiler 15, 18 and 30kW

Clearances:

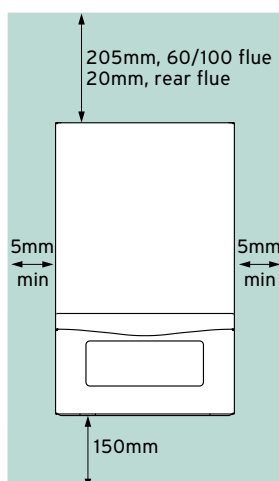

Dimensions:

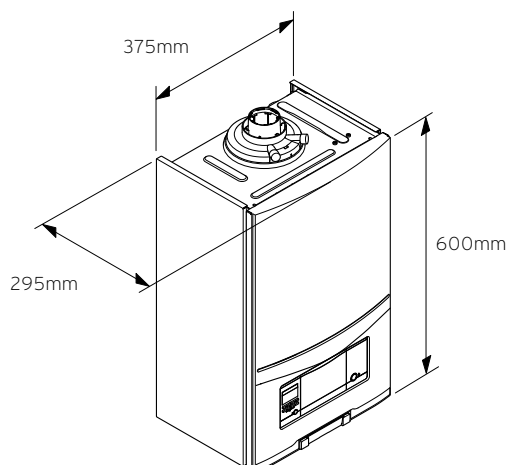

Note: A minimum of 600mm clearance in front of the boiler is required to enable easy access for servicing. This can be reduced to 5mm if fitted behind removable door/panel.

| Technical data | Unit of measure | 25kW | 30kW | 35kW |
|---|-----------------|-----------------|-----------------|-----------------|
| Boiler type | | Combination | Combination | Combination |
| Article number | | 0010020392 | 0010020393 | 0010020394 |
| PCDB number | | 017958 | 017959 | 017960 |
| Boiler dimensions (H x W x D) | mm | 700 x 390 x 295 | 700 x 390 x 295 | 700 x 390 x 295 |
| Flue options | | Top / rear | Top / rear | Top / rear |
| Maximum flue length (60/100) horizontal/vertical | m | 10 / 10 | 10 / 10 | 10 / 10 |
| Maximum flue length (80/125) horizontal/vertical | m | 25 / 25 | 25 / 25 | 25 / 25 |
| Boiler lift weight - dry boiler | kg | 32 | 33 | 33 |
| Nominal heat output range at 50/30 °C (condensing mode) | kW | 5.3 - 19.1 | 6.3 - 19.1 | 7.5 - 19.1 |
| Nominal heat output range at 80/60 °C (condensing mode) | kW | 5.1 - 18.3 | 6.1 - 18.3 | 7.2 - 18.3 |
| Maximum flow temperature | °C | 80 | 80 | 80 |
| Flow temperature range | °C | 10 - 80 | 10 - 80 | 10 - 80 |
| Domestic hot water flow rate (at ΔT = 35K) | l/min | 10.4 | 12.2 | 14.1 |
| Flow temperature factory setting | °C | 75 | 75 | 75 |
| PCDB seasonal efficiency (SAP 2012) | % | 89.3 | 89.3 | 89.3 |
| ErP efficiency | % | 93 | 93 | 93 |
| ErP rating (heating/hot water) | A+++ - D/A+ - F | | | |
| Sound power/ErP decibel rating | dB(A) | 49 | 44 | 45 |
| NOx (En 15502-2-1) | mg/kWh | 38 | 38 | 37 |
| | | 15kW | 18kW | 30kW |
| Boiler type | | System | System | System |
| Article number | | 0010025271 | 0010025272 | 0010025273 |
| PCDB number | | 018403 | 018404 | 018405 |
| Boiler dimensions (H x W x D) | mm | 700 x 390 x 295 | 700 x 390 x 295 | 700 x 390 x 295 |
| Flue options | | Top / rear | Top / rear | Top / rear |
| Maximum flue length (60/100) horizontal/vertical | m | 10 / 10 | 10 / 10 | 10 / 10 |
| Maximum flue length (80/125) horizontal/vertical | m | 25 / 25 | 25 / 25 | 25 / 25 |
| Boiler lift weight - dry boiler | kg | 32 | 33 | 33 |
| Nominal heat output range at 50/30 °C (condensing mode) | kW | 4.7 - 15.9 | 5.2 - 19.1 | 7.5 - 31.8 |
| Nominal heat output range at 80/60 °C (condensing mode) | kW | 4.5 - 15.2 | 5.0 - 18.3 | 7.2 - 30.5 |
| Maximum flow temperature | °C | 80 | 80 | 80 |
| Flow temperature range | °C | 10 - 80 | 10 - 80 | 10 - 80 |
| Flow temperature factory setting | °C | 75 | 75 | 75 |
| PCDB seasonal efficiency (SAP 2012) | % | 89.8 | 89.7 | 89.8 |
| ErP efficiency | % | 94 | 94 | 94 |
| ErP rating (heating) | A+++ - D/A+ - F | | | |
| Sound power/ErP decibel rating | dB(A) | 48 | 49 | 54 |
| NOx (En 15502-2-1) | mg/kWh | 33 | 39 | 40 |
| | | 15kW | 18kW | 30kW |
| Boiler type | | Open vent | Open vent | Open vent |
| Article number | | 0010025274 | 0010025275 | 0010025276 |
| PCDB number | | 018400 | 018401 | 018402 |
| Boiler dimensions (H x W x D) | mm | 600 x 375 x 295 | 600 x 375 x 295 | 600 x 375 x 295 |
| Flue options | | Top / rear | Top / rear | Top / rear |
| Maximum flue length (60/100) horizontal/vertical | m | 10 / 10 | 10 / 10 | 10 / 10 |
| Maximum flue length (80/125) horizontal/vertical | m | 25 / 25 | 25 / 25 | 25 / 25 |
| Boiler lift weight - dry boiler | kg | 22 | 22 | 22 |
| Nominal heat output range at 50/30 °C (condensing mode) | kW | 4.7 - 15.9 | 5.2 - 19.1 | 7.4 - 31.8 |
| Nominal heat output range at 80/60 °C (condensing mode) | kW | 4.5 - 15.2 | 5.0 - 18.3 | 7.1 - 30.5 |
| Maximum flow temperature | °C | 80 | 80 | 80 |
| Flow temperature range | °C | 10 - 80 | 10 - 80 | 10 - 80 |
| Flow temperature factory setting | °C | 75 | 75 | 75 |
| PCDB seasonal efficiency (SAP 2012) | % | 89.8 | 89.7 | 89.8 |
| ErP efficiency | % | 94 | 94 | 94 |
| ErP rating (heating) | A+++ - D/A+ - F | | | |
| Sound power/ErP decibel rating | dB(A) | 48 | 51 | 55 |
| NOx (En 15502-2-1) | mg/kWh | 33 | 39 | 40 |

10 * Vaillant combination boilers are fitted with a flow regulator set to achieve a temperature rise of 42°C. This maintains comfortable bathing and showering during the colder months of the year.



Project background

Wheeldon Homes, Derby

Building type

A range of properties, from two-bedroom starter to five-bedroom family homes, reflecting the belief that Building Excellence lies at the heart of every Wheeldon home.

Boilers used

ecoFIT sustain 24kW boilers



ecoFIT sustain combi boilers 30 - 35kW boilers



Controls used

VRC 700 and VR 920 heating controls



vSMART app-based heating controls



Quality, reliability and value

Wheeldon Homes was attracted by the Vaillant brand's reputation for quality, reliability and value, which also helped to sell their properties to discerning customers.

Wheeldon was also impressed by the eco credentials of Vaillant boilers. By choosing the ErP A-rated ecoFIT sustain boilers fitted with weather and load compensating controls, they were able to demonstrate their commitment to reducing emissions and increasing efficiency - a must for Wheeldon. Deciding to install app-based, smart controls was a great choice by Wheeldon and they received excellent feedback from their customers on the controls chosen.

By selecting ecoFIT sustain models for their specification, Wheeldon Homes could offer their customers high performance boilers with cupboard fit dimensions and rear flues that fit discreetly in their new homes.

The Vaillant brand's service and support offerings were another factor in Wheeldon's choice. Vaillant has a 98% first-fix rate, bespoke service and guarantee packages and a comprehensive range of services to support specifiers at every stage of their project.

About Wheeldon Homes

- Medium-sized property developer based in Derbyshire
- Full heating systems provided by Vaillant, including boilers, cylinders and controls
- Commissioned first trial of Vaillant's new VRC 700 and VR 920 heating controls, which connect the boilers to the internet
- Emphasis on quality, reliability and value

Installers

Neil Shacklock Plumbing & Heating
MCK Plumbing & Heating Engineers

Why Vaillant?

Production Director Andy Startin said: "From the outset, we have been impressed with Vaillant's exceptional level of innovation, combined with its ability to work to deadlines, product knowledge, industry awareness, and ability to deliver projects on time and to agreed budgets. From the initial tender stage, through to customer service on occupied properties, Vaillant has always adopted a professional and methodical approach and updated us regularly on its progress."

ecoTEC sustain

Combination boiler range



Overview

The ecoTEC sustain range of combination boilers have been designed especially for the specification market with ease of use, maintenance and reliability in mind.

The ecoTEC sustain has a highly efficient stainless steel heat exchanger that delivers a high SAP rating, ensuring compliance with building regulations.

Features & benefits



Compact dimensions

For flexible siting options (ecoTEC sustain has the same footprint as the ecoTEC pro).



Front access for service and maintenance

For quick and efficient access once installed in a property.



ErP 'A' rated product

Suitable for both refurbishment and new build specifications, reducing energy use.



High-quality heat exchanger

Stainless steel heat exchanger designed for long life and easy maintenance.



Patented condensate trap

Easy install with a safety back-up.



Compatible with aroTHERM air source heat pump hybrid system

The perfect entry into renewable systems.



Fully modulating burner, with low NOx

The burner matches the system load effectively and reduced NOx helps keep air clean.



Grundfos high-efficiency pump

Modulating high-torque pump uses less energy, reducing carbon outputs.

* ecoTEC sustain 834 only.



Technical data

ecoTEC sustain combination boilers 24, 28 and 34kW

Clearances:

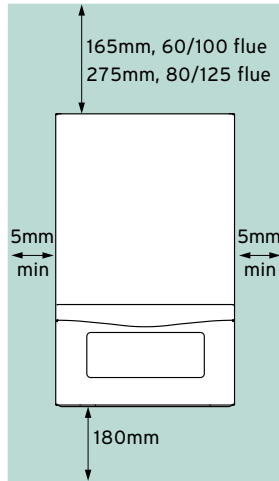

Dimensions:

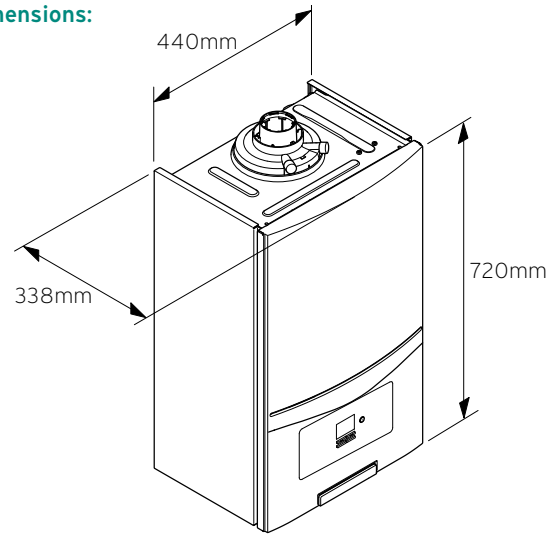

Note: A 500mm front clearance is recommended to allow easy access during inspection and maintenance.

| Technical data | Unit of measure | 24kW | 28kW | 34kW |
|---|-----------------|-----------------|-----------------|-----------------|
| Boiler type | | Combination | Combination | Combination |
| Article number | | 0010019980 | 0010019981 | 0010019982 |
| PCDB number | | 018118 | 018119 | 018120 |
| Boiler dimensions (H x W x D) | mm | 720 x 440 x 338 | 720 x 440 x 338 | 720 x 440 x 338 |
| Flue options | Top/Rear | Top | Top | Top |
| Maximum flue length (60/100) horizontal/vertical | m | 9 / 10 | 9 / 10 | 10 / 11 |
| Maximum flue length (80/125) horizontal/vertical | m | 23 / 23 | 28 / 28 | 31 / 31 |
| Boiler lift weight - dry boiler | kg | 30.8 | 30.8 | 32.8 |
| Nominal heat output range at 50/30 °C (condensing mode) | kW | 7.0 - 20.1 | 8.0 - 20.1 | 9.1 - 19.9 |
| Nominal heat output range at 80/60 °C (condensing mode) | kW | 6.4 - 18.5 | 7.4 - 18.5 | 8.4 - 18.5 |
| Maximum flow temperature | °C | 80 | 80 | 80 |
| Flow temperature range | °C | 30 - 80 | 30 - 80 | 30 - 80 |
| Domestic hot water flow rate (at ΔT = 35K) | l/min | 9.9 | 11.6 | 14.1 |
| Flow temperature factory setting | °C | 75 | 75 | 75 |
| PCDB seasonal efficiency (SAP 2012) | % | 89.2 | 89.1 | 89.2 |
| ErP efficiency | % | 92 | 92 | 92 |
| ErP rating (heating/hot water) | A+++ - D/A+ - F | A/A | A/A | A/A |
| Sound power/ErP decibel rating | dB(A) | 49 | 48 | 43 |
| NOx ErP label | mg/kWh | 33 | 43 | 49 |

* Vaillant combination boilers are fitted with a flow regulator set to achieve a temperature rise of 42°C. This maintains comfortable bathing and showering during the colder months of the year.

ecoTEC plus

Combination and system boilers



Overview

The Vaillant ecoTEC plus combination and system boiler ranges have been refined and taken to the next level. Paired with our plug-and-play internet gateway, myVAILLANT connect, it enables app control, smart home integration and remote appliance care and support in minutes, for increased efficiency and first-class customer service.

Beneath its familiar curved case, the internal layout of the ecoTEC plus has been finely tuned to ensure all components are easily accessible, making maintenance and servicing straightforward, and installation effortless. The semi-touch interface ensures easy, intuitive operation, while enhanced connectivity opens up more possibilities for remote diagnostics, performance monitoring and control.

Features & benefits



Smart home ready when used with myVAILLANT connect

The myVAILLANT connect internet gateway accessory works seamlessly with this range of ecoTEC plus boilers enabling easy connection to Vaillant controls with app connectivity and smart speaker integration** in minutes.



Familiar footprint and external layout

Retaining the same case dimensions, boiler footprint, flue position and pipe connections for an effortless like-for-like swap.



Intuitive semi-touch interface***

Allowing for effortless first-time installation and set-up, with guided commissioning and set up wizard and easy to follow navigation.



Automatic LPG conversion on most outputs****

Completed in minutes using the intuitive interface, with no additional parts required.



IoniDETECT technology

Intelligent gas combustion monitoring, helping the ecoTEC plus reach wider modulation range of up to 1:11, for even greater system efficiency.



Sharpened intelligence with LIN bus technology

Enables more intelligent and accurate reading of flow rate and pressure differential via internal pump for improved performance.

* Excluding ecoTEC plus 635.

** Compatible with the senso controls range and the VRC 700. Only for use with single heating zones.

*** New interface design not compatible with the timeSWITCH 150 and timeSWITCH 160.

**** Excluding ecoTEC plus 840, 940 and 635.

Technical data

ecoTEC plus combination boiler 26, 32, 36 and 40kW

Clearances:

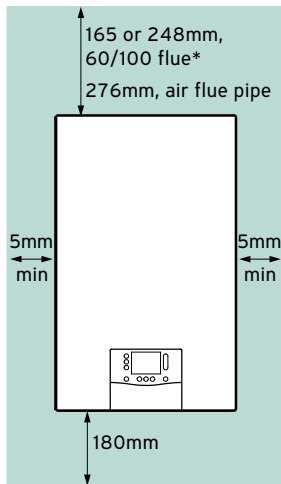

* See mounting template

Dimensions:

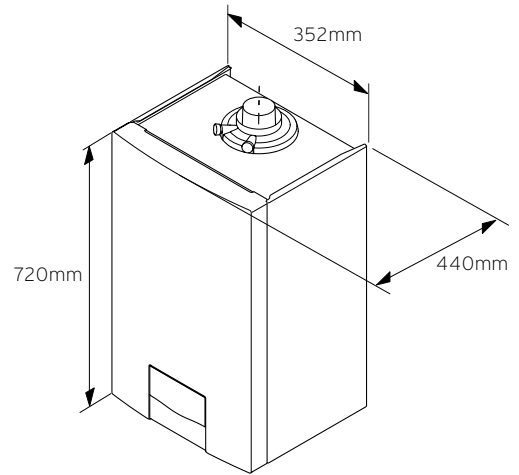

ecoTEC plus system boiler 10, 15, 20, 25, 30 and 35kW

Clearances:

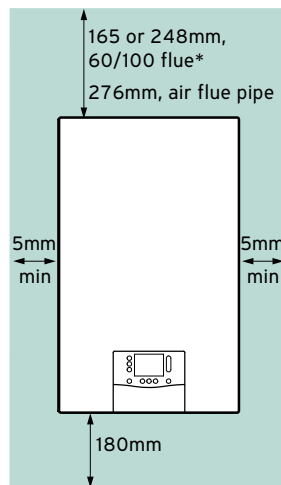

* See mounting template

Dimensions:

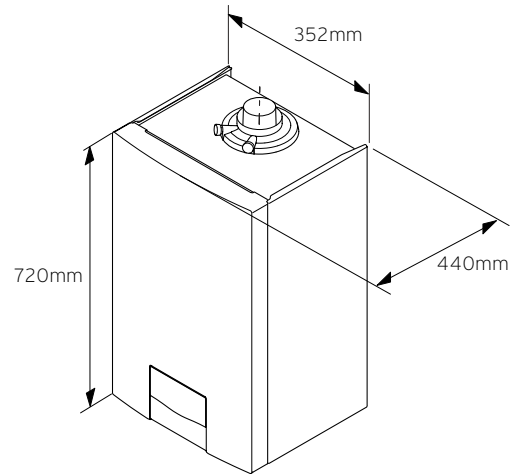

Note: a 500mm front clearance is recommended to allow easy access during inspection and maintenance. Can be reduced to 5mm if fitted behind removable door/panel.

| Technical data | Unit of measure | ecoTEC plus 826 | ecoTEC plus 832 | ecoTEC plus 836 | ecoTEC plus 840 |
|--|---------------------|--------------------|-----------------|-----------------|-----------------|
| General | | | | | |
| Boiler type | | Combination | | | |
| LPG compatible | Yes/No | Yes - adaptive | | | No |
| Article number | | 0010036015 | 0010036016 | 0010036017 | 0010036018 |
| Dimensions | | | | | |
| Boiler dimensions (H x W x D) | mm | 720 x 440 x 352 | | | 720 x 440 x 386 |
| Side clearance | mm | 5 | | | |
| Top clearance (with 60/100 flue) | mm | 165 | | | |
| Top clearance if using rear flue | mm | N/A | | | |
| Bottom clearance | mm | 180 | | | |
| Front clearance* | mm | 500 | | | |
| Performance | | | | | |
| NOx ErP label | mg/kWh | 33.0 | 27.0 | 28.0 | 26.0 |
| ErP efficiency | % | 93 | 94 | | |
| ErP decibel rating (sound power) | dB(A) | 46 | 45 | 47 | 49 |
| ErP efficiency Heating / DHW | A+++ to D / A+ to F | A / A | | | |
| Heating | | | | | |
| Nominal heat output range at 50/30°C (condensing mode) | kW | 2.8 - 21.2 | 3.9 - 26.5 | 4.2 - 32.2 | 5.0 - 32.3 |
| Nominal heat output range at 80/60°C (non condensing mode) | kW | 2.5 - 19.8 | 3.5 - 24.9 | 3.7 - 29.9 | 4.5 - 29.8 |
| Flow temperature range (factory setting - 75°C) | °C | 30 - 85 | | | |
| Modulation (max/min) | 1 : X | 1:11 | 1:9 | 1:10 | 1:9 |
| Domestic hot water | | | | | |
| Maximum heat output for water generation | kW | 26.5 | 32.6 | 36.7 | 40.8 |
| Lowest water pressure to operate boiler | bar | 0.7 | | | |
| Lowest water flow for operation | l/min | 2.0 | | | |
| Domestic hot water flow rate (at Δ30°C)** | l/min | 12.4 | 15.2 | 17.0 | 19.0 |
| Domestic hot water flow rate (at Δ35°C)** | l/min | 10.6 | 13.0 | 14.6 | 16.3 |
| Hot water output temperature range | °C | 35-65 | | | |
| Mechanical | | | | | |
| Gas inlet connection (pipe size) | mm | 15 | | | 22 |
| Heating flow and return connections (pipe size) | mm | 22 | | | |
| Hot and cold water connections (pipe size) | mm | 15 | | | |
| Heat exchanger material | Stainless/Aluminium | Stainless steel | | | |
| Filling loop supplied | Yes/No | Yes | | | |
| Boiler lift weight (dry boiler) | kg | 36 | 37 | | 41 |
| Spacer frame available | Yes/No | Yes | | | |
| Fluing options | | | | | |
| Maximum horizontal flue length 60/100 | m | 10 | 8 | | |
| Maximum vertical flue length 60/100 | m | 10 | 8 | | |
| Maximum horizontal flue length 80/125 | m | 28 | | | |
| Maximum vertical flue length 80/125 | m | 30 | | | |
| Rear flue options | Yes/No | No | | | |
| Permissible flue classifications | | C13, C33, C43, C53 | | | |

* Can be reduced to 5mm if fitted behind a door / panel which then gives 500mm once removed / opened.

** Vaillant combination boilers are fitted with a flow regulator set to achieve a temperature rise of 42°C. This maintains comfortable bathing and showering during the colder months of the year.

| Technical data | Unit of measure | ecoTEC plus 610 | ecoTEC plus 615 | ecoTEC plus 620 | ecoTEC plus 625 | ecoTEC plus 630 | ecoTEC plus 635 | |
|--|---------------------|--------------------|-----------------|-----------------|-----------------|-----------------|-----------------|--|
| General | | | | | | | | |
| Boiler type | | System | | | | | | |
| LPG compatible | Yes/No | Yes - adaptive | | | | | No | |
| Article number | | 0010036009 | 0010036010 | 0010036011 | 0010036012 | 0010036013 | 0010036014 | |
| Dimensions | | | | | | | | |
| Boiler dimensions (H x W x D) | mm | 720 x 440 x 352 | | | | | 720 x 440 x 386 | |
| Side clearance | mm | 5 | | | | | | |
| Top clearance (with 60/100 flue) | mm | 165 | | | | | | |
| Top clearance if using rear flue | mm | N/A | | | | | | |
| Bottom clearance | mm | 180 | | | | | | |
| Front clearance* | mm | 500 | | | | | | |
| Performance | | | | | | | | |
| NOx ErP label | mg/kWh | 36.0 | 36.0 | 33.0 | 27.0 | 28.0 | 27.0 | |
| ErP efficiency | % | 92 | 93 | | 94 | | | |
| ErP decibel rating (sound power) | dB(A) | 37 | 42 | 45 | 46 | 48 | 52 | |
| ErP efficiency Heating / DHW | A+++ to D / A+ to F | A / A | | | | | | |
| Heating | | | | | | | | |
| Nominal heat output range at 50/30°C (condensing mode) | kW | 2.8 - 10.6 | 2.8 - 15.9 | 2.8 - 21.2 | 3.9 - 26.5 | 4.2 - 32.2 | 5.0 - 37.7 | |
| Nominal heat output range at 80/60°C (non condensing mode) | kW | 2.5 - 9.9 | 2.5 - 14.8 | 2.5 - 19.8 | 3.5 - 24.9 | 3.7 - 29.9 | 4.5 - 34.9 | |
| Flow temperature range (factory setting - 75°C) | °C | 30 - 85 | | | | | | |
| Modulation (max/min) | 1 : X | 1:8 | | 1:9 | 1:8 | 1:9 | | |
| Domestic hot water | | | | | | | | |
| Maximum heat output for water generation | kW | 19.6 | 19.6 | 23.6 | 29.6 | 34.3 | 39.4 | |
| Mechanical | | | | | | | | |
| Gas inlet connection (pipe size) | mm | 15 | | | | | 22 | |
| Heating flow and return connections (pipe size) | mm | 22 | | | | | | |
| Heat exchanger material | Stainless/Aluminium | Stainless steel | | | | | | |
| Filling loop supplied | Yes/No | No | | | | | | |
| Boiler lift weight (dry boiler) | kg | 34 | | | 36 | | 40.5 | |
| Spacer frame available | Yes/No | Yes | | | | | | |
| Fluing options | | | | | | | | |
| Maximum horizontal flue length 60/100 | m | 16 | | | 8 | | | |
| Maximum vertical flue length 60/100 | m | 12 | | | 8 | | | |
| Maximum horizontal flue length 80/125 | m | 28 | | | | | | |
| Maximum vertical flue length 80/125 | m | 30 | | | | | | |
| Rear flue options | Yes/No | No | | | | | | |
| Permissible flue classifications | | C13, C33, C43, C53 | | | | | | |

* Can be reduced to 5mm if fitted behind a door / panel which then gives 500mm once removed / opened.

What are heat pumps?

Heat pumps use the energy that nature gives us for free, so they're cheaper and more eco-friendly than conventional appliances that use fossil fuels

Air source system

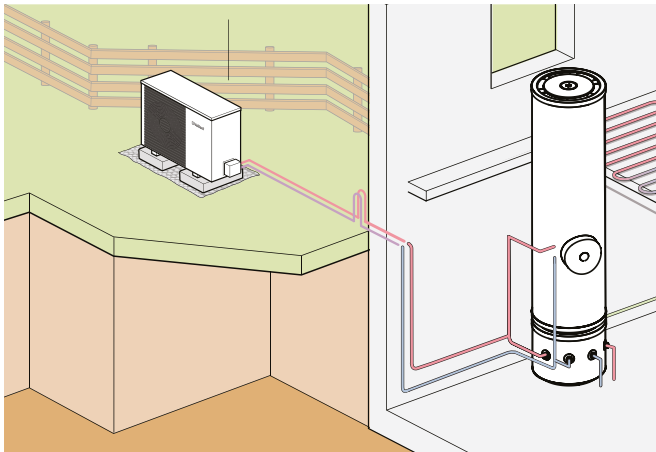

Air source

Air source heat pumps extract thermal energy (heat) from the outside air and convert this into heating and hot water. Vaillant's heat pumps are designed to work in cold temperatures and are suitable for a range of homes, from a small apartment to a large detached home. 75% of energy used to operate the heat pump comes from the renewable source outside helping to reduce emissions and CO₂ impact.

flexoTHERM with fluoCOLLECT for water source systems

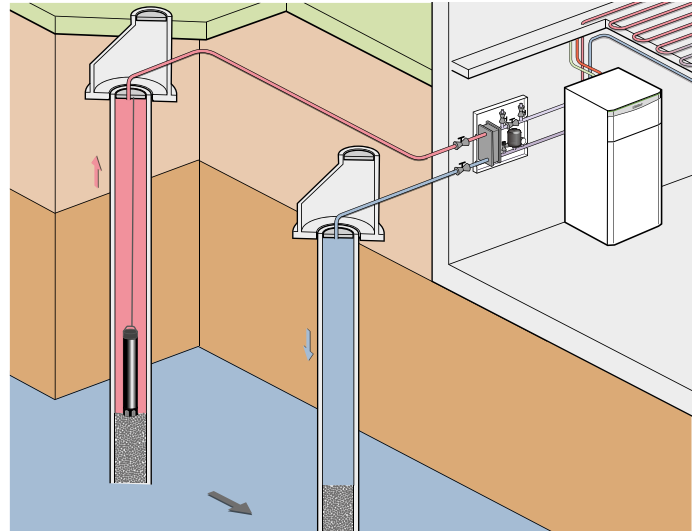

Water source

Heat pumps can draw heat from water. The temperature of the water is constant regardless of the season and the outside temperature. Extracting heat from water requires access to lakes, wells or streams.

Ground array system example

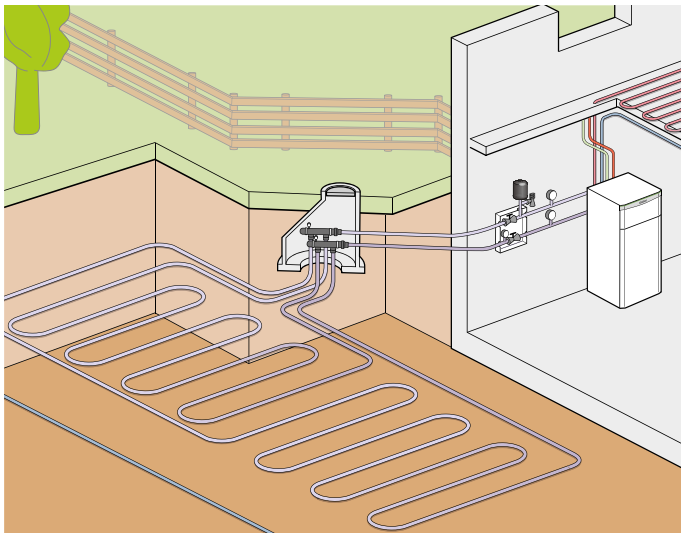

Ground source

Ground source heat pumps draw thermal energy from the ground. This heat can be collected via horizontal collectors or vertical boreholes.

Horizontal - Horizontal collectors are installed across a large area at a depth of approximately 1.2 metres, where the temperature remains almost uniform for the whole year, all over the world.

Borehole system example

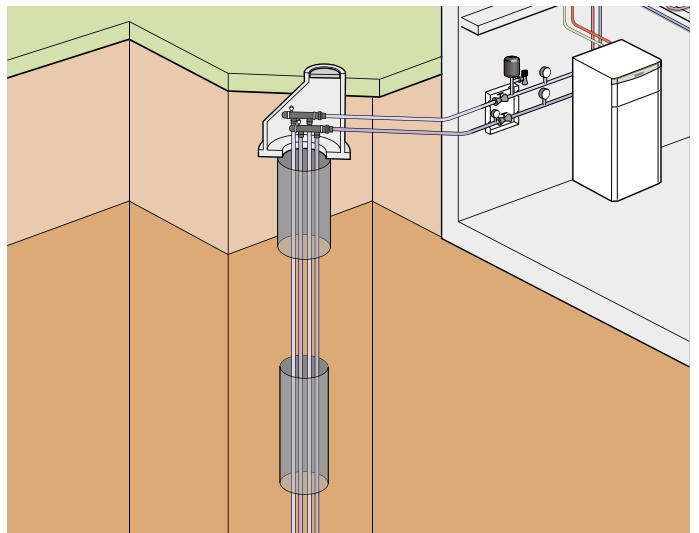

Vertical - Vertical collectors are installed in space-saving boreholes. Special ground probes extract the latent heat in the ground as much as 125 metres deep into the earth, where the temperature is constantly 10 - 12°C all year long.

Setting the standard



Natural refrigerant R290 in heat pumps

Setting new standards in the heating market has been Vaillant tradition for years. With the launch of the award winning aroTHERM plus in 2020, Vaillant set the benchmark by introducing the natural refrigerant R290 to our heat pump range. It has clear advantages over alternative refrigerants: approximately 75% less filling quantity is needed; it has low Global Warming Potential* (GWP) and provides significant product benefits for your customers. Using R290 means Vaillant heat pumps can achieve a high flow temperature of up to 75°C if required. Setting the flow to this maximum temperature for hot water means that an electric immersion heater for legionella protection isn't necessary.

What is R290?

It's the technical name for the natural refrigerant also known as propane. R290 is already commonly used in many parts of our daily life, such as in refrigerators, air conditioning or even hairspray - Vaillant was one of the first companies to introduce this refrigerant in heat pumps.



*What is Global Warming Potential (GWP)?

GWP is a comparative value that indicates the greenhouse effect of a greenhouse gas, such as a refrigerant, if it were to be released into the environment. The higher the value, the worse the impact on the climate.

Example GWPs of some refrigerants:

| | |
|-----------------|-------|
| CO ₂ | 1 |
| R290 | 3 |
| R32 | 675 |
| R410A | 2,088 |

The value indicates the amount of CO₂ which has an equal global warming effect. To calculate the CO₂ impact of a refrigerant, the amount contained in the heat pump is multiplied by its GWP value.

R290 brings unbeatable benefits to our heat pumps:

- Improved SCoP of up to 5.03 for lower running costs
- Flow temperatures of up to 75°C from the heat pump are achievable
- Higher hot water comfort and legionella protection without back-up heater
- Low GWP of 3 - exceptionally eco-friendly
- Stable service costs over product life cycle



Example calculation

R410A

1.8 kg of R410A x 2,088 GWP
= **3,760 kg CO₂**

R290 (aroTHERM plus)

0.6 kg of R290 x 3 GWP
= **1.8 kg CO₂**

aroTHERM plus

Air source heat pump



Overview

The aroTHERM plus is our flagship air source heat pump range, available in a wide range of heat output sizes for many types of property with 3.5, 5, 7, 10 and 12kW models available.

This heat pump continues to win awards around the world for its innovative use of the refrigerant R290, which gives it a Global Warming Potential (GWP) of just 3. This refrigerant is already used in household appliances all over the world and offers many advantages over refrigerants traditionally used in heat pumps. Coupled with market leading technical features that improve efficiency and deliver higher flow temperatures, the aroTHERM plus is perfect for new and existing heating systems (including hybrid). It's also impressively quiet in operation and has been certified by Quiet Mark, making it suitable for use even in densely built-up terraced housing estates.

Features & benefits



High performance ASHP range

With a flow temperature of up to 75°C, the aroTHERM plus can deliver more usable hot water with high hot water comfort levels whilst removing the need for direct electric immersion to sterilise the water, protecting from legionella.



Super quiet operation

From just three metres away, the acoustic pressure level is less than 30 dB(A) for easier planning and siting.



Higher energy-efficiency performance

With a SCoP of up to 5.03, the aroTHERM plus is extremely energy efficient, enabling high energy savings against certain fossil fuels.



R290 natural refrigerant with Low GWP

Already fulfilling the next NZEB requirements, the aroTHERM plus uses monobloc technology with a hermetically sealed refrigerant circuit.



Fully adaptable system approach

The aroTHERM plus can also be combined with photovoltaic systems and integrated into smart power grids (SG-ready), so your customers can enjoy the benefits of variable electricity tariffs.



Quality by design

Suitable for coastal installations with salt resistant construction C5 class.

| Technical data | Unit | 3.5kW | 5kW | 7kW | 10kW (230V) | 12kW (230V) | 10kW (400V) | 12kW (400V) | |
|---|-------------------|---|-----|-------------------|---------------------|-------------|-----------------------------------|-------------|--|
| General | | | | | | | | | |
| Product dimensions (H x W x D) | mm | 765 x 1,100 x 450 | | 965 x 1,100 x 450 | 1,565 x 1,100 x 450 | | | | |
| Weight, ready for operation | kg | 114 | | 128 | 194 | | 210 | | |
| Connection, heating circuit | | G 1 1/4" | | | | | | | |
| Rated voltage | | 230 V (+10%/-15%), 50 Hz, 1~/N/PE | | | | | 400 V (+10%/-15%), 50 Hz, 3~/N/PE | | |
| Rated current, maximum | A | 14.3 | | 15.0 | 23.3 | | 15 | | |
| Fuse size | A | 16 | | | 25 | | 16 | | |
| Fuse type | | Characteristic C, slow-blow, singlepole switching | | | | | | | |
| RCD type | | Type B rated to 20kHz or greater and with a minimum trigger point of 150mA above 1kHz | | | | | | | |
| eBUS (2-core communication cable) | mm ² | 0.75 | | | | | | | |
| Maximum length eBUS cable (polarity sensitive) | m | 50 | | | | | | | |
| IP rating | | IP 15 B | | | | | | | |
| Fan power consumption | W | 40 | | | 50 | | | | |
| Fan quantity | | 1 | | | 2 | | | | |
| Fan air flow, maximum | m ³ /h | 2300 | | | 5100 | | | | |
| Heating pump, power consumption | W | 2 - 50 | | | 3 - 87 | | | | |
| Heating circuit | | | | | | | | | |
| Heating water temperature, minimum/maximum | °C | 20 - 75 | | | | | | | |
| Basic length of the heating water pipe, maximum, between the outdoor unit and indoor unit | m | 20 | | | | | | | |
| Maximum static height difference between outdoor unit and the highest point in the heating system | m | 18 | | | 13 | | | | |
| Minimum operating pressure | bar | 0.5 | | | | | | | |
| Maximum operating pressure | bar | 3.0 | | | 2.5 | | | | |
| Minimum volume flow | l/h | 400 | | 540 | 995 | | | | |
| Maximum volume flow | l/h | 860 | | 1205 | 2065 | | | | |
| Water volume, in the outdoor unit | l | 1.5 | | 2.0 | 4.5 | | | | |
| Minimum open water volume | l | 15 | | 20 | 45 | | | | |
| Refrigerant circuit | | | | | | | | | |
| Fluid type | | R290 | | | | | | | |
| Fluid fill quantity | kg | 0.6 | | 0.9 | 1.3 | | | | |
| Refrigerant, Global Warming Potential (GWP) | | 3 | | | | | | | |
| CO ₂ equivalent | t | 0.0018 | | 0.0027 | 0.0039 | | | | |
| Permissible operating pressure | bar | 31.5 | | | | | | | |
| Compressor type | | Rotary piston | | | Scroll compressor | | | | |
| Compressor oil type | | Specific polyalkylene glycol (PAG) | | | | | | | |
| Compressor, control | | Electronic | | | | | | | |
| Noise emissions, heating mode | | | | | | | | | |
| Sound power, EN 12102, EN 14511 LWA, A7/W35 | dB(A) | 48 | | 49 | 51 | | | | |
| Sound power, EN 12102, EN 14511 LWA, A7/W55 | dB(A) | 48 | | 49 | 51 | | | | |
| Efficiency | | | | | | | | | |
| Energy efficiency class 35°C | (A+++ to F) | A++ | | A+++ | | | | | |
| Energy efficiency class 55°C | (A+++ to F) | A+ | | A++ | | | | | |
| Combination with uniTOWER | | | | | | | | | |
| Energy efficiency class | (A+++ to F) | A+ | | | A++ | | | | |
| Energy efficiency class, hot water | (A+ to F) | A | | | A | | | | |

aroTHERM split

Air source heat pump



Overview

The aroTHERM split has been designed for quick and flexible installation. aroTHERM split consists of two modules, an indoor wall-mounted unit and an outdoor unit. The heat pump has various output sizes to cater for different types of property, with 3.5, 5, 7, 10 and 12kW models available. Heat pump outputs are sized for the heating requirement of the individual property which is why they have smaller outputs than combi boilers (which focus on hot water heating).

The aroTHERM split is extremely quiet. From just three metres away, the acoustic pressure level is less than 30 dB(A). To get the best performance out of your heat pump, a system approach is required to ensure that all elements of your customer's property work in harmony.

Features & benefits



Easy installation

Designed with improved transport and handling so it can be installed and commissioned in one day.



Sound Safe System

Exceptionally quiet operation allows for flexible siting options.



A+++ ErP rating

Highly efficient for lower running costs.



Standard footprint

All outputs have the same footprint for simplified specification and installation.



App based proprietary control measure

With installation wizard for easy set-up and weather compensation as standard, all controlled via a smartphone.



Pre-charged 15 metre pipe

The outdoor unit can be discreetly installed, wall-mounted or floor-standing, depending on the household's outdoor space and it can even be installed up to 25m away from your customer's property.



Flexible energy solution

Can link with other appliances such as solar PV to reduce running costs even further.

| Technical data | Unit | 3.5kW | 5kW | 7kW | 10kW (230V) | 12kW (230V) | 10kW (400V) | 12kW (400V) | |
|--|-------------------|---|-------------------|---------------------|-------------|-------------|-----------------------------------|-------------|--|
| General | | | | | | | | | |
| Product dimensions (H x W x D) | mm | 765 x 1,100 x 450 | 965 x 1,100 x 450 | 1,565 x 1,100 x 450 | | | | | |
| Weight, ready for operation | kg | 92.2 | 106.3 | 162.2 | 181.5 | | | | |
| Connection technology, refrigerant pipe | | Flared | | | | | | | |
| Rated voltage | V | 230 V (+10%/-15%), 50 Hz, 1~/N/PE | | | | | 400 V (+10%/-15%), 50 Hz, 3~/N/PE | | |
| Rated current, maximum | A | 11.5 | 14.9 | 21.3 | 13.5 | | | | |
| Fuse size | A | 16 | | 25 | | 16 | | | |
| Fuse type | | Characteristic C, slow-blow, single-pole switching | | | | | | | |
| RCD type | | Type B rated to 20kHz or greater and with a minimum trigger point of 150mA above 1kHz | | | | | | | |
| eBUS (2-core communication cable) | mm ² | 0.75 | | | | | | | |
| Maximum length eBUS cable (polarity sensitive) | m | 50 | | | | | | | |
| IP rating | | IP15B | | | | | | | |
| Fan power consumption | W | 50 | | | | | | | |
| Fan quantity | | 1 | | 2 | | | | | |
| Fan air flow, maximum | m ³ /h | 2300 | | 5100 | | | | | |
| Heating pump, power consumption | W | 2 - 50 | | 3 - 87 | | | | | |
| Refrigerant circuit | | | | | | | | | |
| Refrigerant pipe material | m | Copper | | | | | | | |
| Minimum basic length of refrigerant pipe | m | 3 | | | | | | | |
| Basic length of the refrigerant pipe with outdoor unit above indoor unit maximum | m | 40 | | | | | | | |
| Permissible height difference, outdoor unit above the indoor unit | m | 30 | | | | | | | |
| Basic length of the refrigerant pipe with indoor unit above outdoor unit maximum | m | 25 | | | | | | | |
| Permissible height difference, indoor unit above the outdoor unit | | 10 | | | | | | | |
| Refrigerant pipe connection type | | Flared | | | | | | | |
| Fluid type | | R410A | | | | | | | |
| Fluid fill quantity | kg | 1.5 | 2.39 | 3.6 | | | | | |
| Refrigerant, Global Warming Potential (GWP) | | 2088 | | | | | | | |
| CO ₂ equivalent | t | 3.13 | 4.99 | 7.5200 | | | | | |
| Permissible operating pressure | bar | 41.5 | | | | | | | |
| Compressor type | | Rotary piston | | | | | | | |
| Compressor oil type | | Specific polyvinyl ether (PVE) | | | | | | | |
| Compressor, control | | Electronic | | | | | | | |
| Noise emissions, heating mode | | | | | | | | | |
| Sound power, EN 12102, EN 14511 LWA, A7/W35 | dB(A) | 51 | 53 | 54 | 58 | 59 | 58 | | |
| Sound power, EN 12102, EN 14511 LWA, A7/W55 | dB(A) | 53 | 54 | | 60 | | | | |
| Efficiency | | | | | | | | | |
| Energy efficiency class 35°C | (A+++ to F) | A+++ | A++ | | A+++ | | A++ | | |
| Energy efficiency class 55°C | (A+++ to F) | A++ | A++ | | A++ | | A++ | | |

Note: Any Vaillant heat pump must be installed with a type B RCD rated to 20kHz or greater and with a minimum trigger point of 150mA above 1kHz.

uniTOWER

Integrated hot water solution



Overview

The uniTOWER contains an integrated 190 litre hot water cylinder and hydraulic components. It is pre-wired for fast and easy installation with the aroTHERM plus to give your customers a fully integrated heating system.

When used in combination with the aroTHERM plus, it will provide the necessary hot water performance your customers require. Alternatively, the wall-hung hydraulic station VWZ MEH 97 can also be combined with a matching hot water cylinder for a full heating system. This is where the small uniSTOR VIH RW 200 or uniSTOR exclusive VIH RW with 300 to 500 litres comes in.

Features & benefits



Neat and compact system solution

The compact unit uniTOWER provides integrated expansion vessel, cylinder and diverter valve in a practical design where additional systems can be extended with a range of optimised accessories.



The perfect DHW partner for aroTHERM plus

uniTOWER delivers a 25% higher DHW solution with >190 litres hot water per day (40°C).



Safe and easy transportation

The split mounting concept of uniTOWER can be installed quickly and easily in 1 day by 2 people and makes transportation easy and installation possible in space restricted areas.



Easy to service

uniTOWER offers straightforward installation and maintenance with all major components accessible from the front.



Installation wizard

Quick and easy guided set up with the Vaillant installation wizard.



High efficiency

Highly efficient delivering lower running costs with ErP rating of A++ for heating and A+ for DHW.

| Technical data | Unit | uniTOWER plus (VIH QW 190 / 6) |
|--|--------|--------------------------------|
| Total storage cylinder capacity | l | 185 |
| Temperature hot water (maximum - with auxiliary heating) | °C | 55 - 75 |
| Dimensions, unpacked (H x W x D) | mm | 1880 x 595 x 693 |
| Weight, unpacked | kg | 146 |
| IP rating | | 10B |
| Auxiliary electric heater | kW | 6kW (230V/50Hz) |
| Heating circuit connections | inches | G1 |
| Heating source connections | inches | G 1¼ |
| Rated power, maximum | kW | 5.4 |
| Rated current, maximum, 230V | A | 23.5 |
| Rated current, maximum, 400V | A | 13.6 |
| Minimum operating pressure | MPa | 0.05 (0.50 bar) |
| Maximum operating pressure | MPa | 0.2 (2.0 bar) |

Scan the QR code
for the case study
on the uniTOWER.



flexoTHERM

Multi-source heat pump



Overview

The flexoTHERM is a versatile heating system that uses heat pump technology to draw natural thermal energy into a building from either the ground, water or air. It comes in heat output sizes for many types of property, with 5, 8, 11, 15 and 19kW models available.

The flexoTHERM modular system can be easily adapted. It can be: a ground source heat pump when connected to a ground loop; an air source heat pump when connected to an aroCOLLECT air source brine collector module, or; a water source heat pump when connected to the fluoCOLLECT module.

Features & benefits



5-year guarantee available

The flexoTHERM comes with a 5-year guarantee as standard.



More power, more efficiency

Integrated EVI super compressor, injects additional refrigerant into the compression cycle.



Exceptionally quiet

With noise levels as low as a modern refrigerator - 42dB(A), flexoTHERM has been Quiet Mark certified (excludes 230V ranges).



Ability to cascade up to seven flexoTHERM heat pumps

Suitable for larger domestic and commercial properties.



Extended capabilities and flexibility

Modular design gives flexoTHERM greater sustainability and flexibility with accessories to enable connection to either air or water sources.



ErP A+++ rating

ErP A+++ rated for both hot water and heating efficiency, when installed using sensoCOMFORT controls.

| Technical data | Unit | 5kW | 8kW | 11kW | 15kW | 19kW |
|---|----------|--|------|------|------|------|
| Product dimensions (H x W x D) | mm | 1183 x 595 x 600 | | | | |
| Weight, with packaging | kg | 155 | 170 | 178 | 185 | 197 |
| Weight, without packaging | kg | 145 | 160 | 168 | 176 | 187 |
| Weight, ready for operation | kg | 151 | 167 | 175 | 187 | 200 |
| Electrical | | | | | | |
| Compressor/heating circuit rated voltage | V / Hz | 3~/N/PE 400 / 50 | | | | |
| Control circuit rated voltage | V / Hz | 1~/N/PE 230 / 50 | | | | |
| Auxiliary heater rated voltage | V / Hz | 3~/N/PE 400 / 50 | | | | |
| Power factor | | cos φ = 0.75 - 0.9 | | | | |
| Required network impedance Z _{max} with inrush current limiter | Ω | ≤0.472 | | | | |
| Fuse type, characteristic C, slow-blow, three-pole switching (disconnection of the three mains connection lines in one switching operation) | | Design in accordance with the selected connection diagrams | | | | |
| Optional on-site residual-current circuit breaker | | RCCB type A (type A pulse current sensitive residual-current circuit breakers) or RCCB type B (type B universal current sensitive residual-current circuit breakers) | | | | |
| Inrush current (with inrush current limiter) | A | ≤ 15 | ≤ 19 | ≤ 22 | ≤ 26 | ≤ 30 |
| Maximum rated current | A | 19.8 | 21.2 | 23.4 | 25.2 | 30.4 |
| Max. electrical power consumption of auxiliary heater | kW | 9 | | | | |
| Minimum electrical power consumption | kW | 1.4 | 2.1 | 2.6 | 3.3 | 4.7 |
| Maximum electrical power consumption | kW | 11.5 | 12.8 | 14.1 | 15.6 | 17.8 |
| IP rating | | IP 10B | | | | |
| Energy-related Products at 35°C | band | A+++* | | | | |
| Energy-related Products at 55°C | band | A+++* | | | | |
| Hydraulic connection | | | | | | |
| Heating flow / return connection | BSP male | G 1½" | | | | |
| Heat source flow / return connection | BSP male | G 1½" | | | | |
| Heating water expansion vessel | BSP male | G ¾" | | | | |
| Heating and brine right angle connections | mm | 35 | | | | |
| Heat source circuit / brine circuit | | | | | | |
| Brine content of the brine circuit in the heat pump | l | 2.5 | 3.1 | 3.6 | 4.5 | 5.3 |
| Minimum operating pressure of brine fluid | bar | 0.7 | | | | |
| Maximum operating pressure of brine fluid | bar | 3 | | | | |
| Maximum electrical power consumption, brine circuit pump | W | 76 | 76 | 130 | 310 | 310 |
| Heating circuit / building circuit | | | | | | |
| Minimum heating circuit operating pressure | bar | 0.7 | | | | |
| Maximum circuit operating pressure | bar | 3.0 | | | | |
| Minimum heating mode flow temperature | °C | 25 | | | | |
| Minimum cooling mode flow temperature | °C | 5 | | | | |
| Maximum heating mode target flow temperature without auxiliary heater | °C | 65 | | | | |
| Maximum heating mode target flow temperature with external auxiliary heater | °C | 75 | | | | |
| Maximum electrical power heating circuit pump | W | 63 | | | 140 | |

* Reported efficiency when used with sensoCOMFORT / RF control.

aroSTOR

Domestic hot water heat pump



Overview

The aroSTOR range of domestic hot water heat pump cylinders include 200 and 270 litre models. It is perfect for additional hot water requirements or as a direct replacement for standard cylinders in smaller houses or multi-tenanted buildings, such as blocks of flats.

This heat pump cylinder is incredibly efficient and sustainable, using thermal energy to heat hot water. This thermal energy can be collected via an external air duct, or it can recycle hot air from within the room where it's installed, provided there is sufficient ventilation. The only other energy needed is the electricity to run the appliance.

Features & benefits



Highly energy efficient and reliable

Highly efficient heat pump cylinder with the best possible ErP label of A+.



High quality material and components

The stainless steel tank comes with a 5-year guarantee (2 years for other components).



Extremely quiet operation

Extremely quiet in operation with additional insulation and use of rubber to lower sound levels even more.



Hot water on demand

A small footprint and range of 360° air duct accessories offers flexible options for siting of the appliance.



1.2 kW titanium electrical back-up heater

Automatically manages your hot water comfort levels with electrical back up heater for hot water boost (and Legionella protection).



Easy to control

aroSTOR heat pumps cylinders come with their own control fixed to the unit. This is a simple turn dial and push button control that has been specifically designed for the aroSTOR.

| Technical data | Unit | 200 | 270 |
|---|-------------------|-------------------------|------|
| Dimensions | | | |
| Nominal capacity | L | 197.5 | 269 |
| Product dimensions, height | mm | 1458 | 1783 |
| Product dimensions, outer diameter | mm | 634 | |
| Weight, with packaging | kg | 75 | 88 |
| Weight, without packaging (cylinder empty) | kg | 55 | 68 |
| Weight, ready for operation (cylinder full) | kg | 255 | 338 |
| Technical data - General | | | |
| Cylinder material | | Stainless steel | |
| Heat insulation | | Polyurethane foam 50 mm | |
| Type of electric heater | | Immersion / Ti | |
| Refrigerant type | Refrigerant type | R290 | |
| Refrigerant volume | kg | 0.15 | |
| Minimum permitted air temperature | °C | -7 | |
| Maximum permitted air temperature | °C | 45 | |
| Sound power level LpA (V1/V2) | dB(A) | 40 / 43 | |
| Sound power level LWA (V1) | dB(A) | 50 / 52 | |
| Heat-up time (environmental air temperature: 7°C, extraction cycle: L) | h | 6.57 | 9.26 |
| Thermal losses 55°C | kW/24h | 1,61 | 1,77 |
| DHW temperature range (HP only) | °C | 30 to 60 | |
| Maximum temperature of DHW HP inlet domestic water | °C | 70 | |
| Minimal air flow range | m ³ /h | 320 | |
| Nominal air flow range | m ³ /h | 350 | |
| Maximum air flow range (non ducted) | m ³ /h | 400 | |
| Maximum hot water temperature (HP + back up heater) | °C | 70 | |
| Maximum cold inlet pressure | mPa / bar | 0.6 / 6 | |
| Expansion vessel pre-charge | mPa / bar | 0.3 / 3 | |
| Expansion valve pressure setting | mPa / bar | 0.6 / 6 | |
| Maximum pressure of the T&P relief valve | mPa / bar | 0.7 / 7 | |
| Maximum temperature of the T&P relief valve | °C | 90 | |
| Length of the T&P valve probe | mm | 900 | 1245 |
| Kiwa certification number | | 1906704/AMD1 | |
| Electrical | | | |
| Maximum electrical power consumption of compressor and auxiliary heater | W | 1900 | |
| Maximum power consumption compressor only | W | 700 | |
| IP rating | | IPX4 | |
| Voltage of the product's power supply | V | 230 | |
| Frequency of the product's power supply | Hz | 50 | |
| Maximum fuse size | A | 13 | |
| Maximum amperage of the power supply circuit | A | 8 | |
| Length of the electrical cable supplied | m | 1.5 | |
| Nominal heat output of the electric back-up heater | kW | 1.2 | |
| Connections | | | |
| Connections for the hot water circuit | Inch | ¾ male | |
| Connections T&P valve | Inch | ½ female | |
| Connections air duct | mm | 160 | |
| Maximum flexible air duct length | m | 10 | |
| Maximum rigid air duct length | m | 20 | |
| Minimum clearance around cylinder | mm | 25 | |
| Minimum distance at front of cylinder | mm | 300 | |
| Minimum distance above cylinder | mm | 300 | |

New uniSTOR slimline cylinders

High recovery range



Overview

Manufactured in Derbyshire specifically for the UK market, our new range of high recovery slimline cylinders provides the ultimate performance and reliability. The high-quality, stainless-steel uniSTOR cylinders are available in a wide range of capacities, from 90 to 210 litres, offering various options for both heat pump and boiler installations.

Designed with simplicity and ease of installation in mind, our pre-plumbed models reduce installation time, while the internal expansion vessel and our brand-new purpose-designed buffer reduces product footprint and allows for more flexible siting.

Features & benefits



25-year guarantee

2-year parts and labour guarantee, with a 25-year anti-corrosion guarantee on the internal stainless-steel tank.



Pre-plumbed options available

Reducing installation time.



uniSTOR plus features an internal expansion vessel

Quick to install, the neater appearance maximises space in tight installation spaces.



Support and knowledge from Vaillant

A range of tutorial videos available to support successful installation and maintenance.



Improved reheat times and system efficiency

Large coil surface area maximises heat transfer to ensure connected Vaillant systems run at their optimum efficiency, reducing running costs with increased hot water performance.



Front facing connections and pipework

Easy to connect pipework when working in tight spaces reducing time during installation.



Labelled connections for simplicity

Easy-to-recognise, giving onsite guidance for installation and maintenance.



Capacities suitable for all customers and property requirements

Slimline range available in outputs from 90 to 210 litres.

uniSTOR pure

High recovery slimline cylinder with external expansion vessel

Coming soon:
A new range of
standard diameter
cylinders



| Technical data | Unit of measure | 90l | 90l pre-plumbed | 150l | 150l pre-plumbed | 175l | 175l pre-plumbed | 210l | 210l pre-plumbed |
|--|-----------------|--------|-----------------|--------|------------------|--------|------------------|--------|------------------|
| Outer diameter with insulation | mm | 490 | | | | | | | |
| Height with insulation | mm | 990 | | 1520 | | 1745 | | 2000 | |
| Net weight (empty cylinder) | kg | 32.9 | 35.6 | 46.3 | 49.3 | 49.9 | 52.9 | 53 | 58.5 |
| Net weight (filled cylinder) | kg | 127.7 | 125.6 | 196.3 | 199.3 | 224.9 | 227.9 | 263 | 258.5 |
| Insulation thickness | mm | 50 | | | | | | | |
| Total tank capacity | L | 94.24 | | 149.84 | | 181.84 | | 206.7 | |
| Actual capacity (without coil volume) | L | 88.4 | | 144 | | 176 | | 199 | |
| Hot water capacity / draw off* | L | 160.54 | | 260.59 | | 318.17 | | 359.56 | |
| Standby losses | kWh/24h | 1.31 | | 1.44 | | 1.76 | | 2.06 | |
| Energy-related Products (ErP) | A+-F | C | | | | | | | |
| Reheat time (70%)* | minutes | 7.39 | | 11.45 | | 14.07 | | 17.45 | |
| Coil rating acc. EN 12897 | kW | | | 22.55 | | | | 28.59 | |
| Heat exchanger volume | L | | | 5.84 | | | | 7.7 | |
| Heat exchanger surface | m ² | | | 1.85 | | | | 2.4 | |
| Primary flow rate | l/h | 2000 | | | | | | | |
| Heat exchanger pressure drop | mbar | | | 0.1 | | | | 0.14 | |
| Maximum operating heat circuit temperature | °C | 85 | | | | | | | |
| Quantity of temperature sensor tubes | qty | 3 | | | | | | | |
| Size of supplied expansion vessel | L | 12 | | | | 18 | | | |
| Immersion heater rating | kW | 3 | | | | | | | |
| Immersion heater cable size | mm | 1.5 | | | | | | | |
| Immersion heater current | A | 13 | | | | | | | |

* Calculation from test EN 12897.

uniSTOR pure

Technical dimensions and clearances

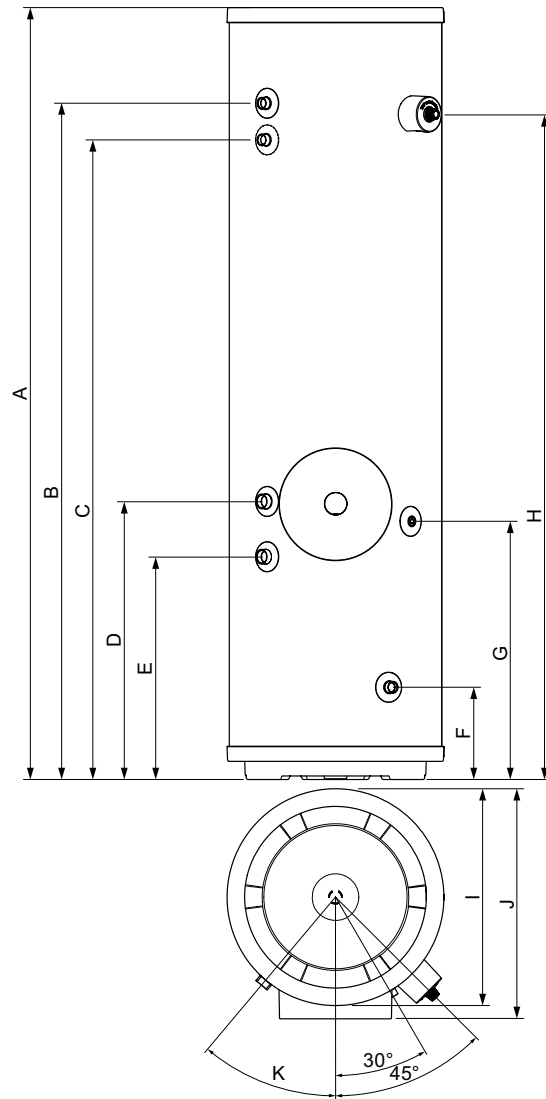

| | A | B | C | D | E | F | G | H | I | J | K |
|---------------------|---------|---------|---------|-------|-------|-------|-------|---------|-----|-----|-----|
| Unit of measure | mm | | | | | | | | | | deg |
| VIH RW 90/5 C SLES | 989.7 | 773.5 | - | 628.5 | 503.5 | 208.5 | 583.5 | 748.5 | 490 | 520 | 40° |
| VIH RW 150/5 C SLES | 1,519.7 | 1,303.5 | - | 628.5 | 503.5 | 208.5 | 583.5 | 1,278.5 | 490 | 520 | 40° |
| VIH RW 175/5 C SLES | 1,744.7 | 1,303.5 | - | 628.5 | 503.5 | 208.5 | 583.5 | 1,503.5 | 490 | 520 | 40° |
| VIH RW 210/5 C SLES | 1,999.7 | 1,783.5 | 1,663.5 | 758.5 | 633.5 | 208.5 | 713.5 | 1,758.5 | 490 | 520 | 40° |

uniSTOR plus

High recovery slimline cylinder
with internal expansion vessel

Coming soon:
A new range of
standard diameter
cylinders



| Technical data | Unit of measure | 150l | 150l pre-plumbed | 175l | 175l pre-plumbed | 210l | 210l pre-plumbed |
|--|-----------------|--------|------------------|--------|------------------|--------|------------------|
| Outer diameter with insulation | mm | 490 | | | | | |
| Height with insulation | mm | 1520 | | 1745 | | 2000 | |
| Net weight (empty cylinder) | kg | 44.2 | 47.2 | 48.6 | 51.6 | 53.4 | 58.9 |
| Net weight (filled cylinder) | kg | 190.3 | 193.3 | 223.6 | 226.6 | 238.4 | 243.9 |
| Insulation thickness | mm | 50 | | | | | |
| Total tank capacity | L | 151.84 | | 177.44 | | 205.1 | |
| Actual capacity (without coil volume) | L | 146 | | 171.6 | | 197.4 | |
| Hot water capacity / draw off* | L | 197.88 | | 221.22 | | 257.86 | |
| Standby losses | kWh/24h | 1.39 | | 1.71 | | 2.01 | |
| Energy-related Products (ErP) | A+-F | C | | | | | |
| Reheat time (70%)* | minutes | 11.45 | | 13.23 | | 15.32 | |
| Coil rating acc. EN 12897 | kW | 22.55 | | 28.59 | | 7.7 | |
| Heat exchanger volume | L | 5.84 | | 7.7 | | 2.4 | |
| Heat exchanger surface | m ² | 1.85 | | 2.4 | | 2000 | |
| Primary flow rate | l/h | 2000 | | | | | |
| Heat exchanger pressure drop | mbar | 0.1 | | 0.14 | | 85 | |
| Maximum operating heat circuit temperature | °C | 85 | | | | | |
| Quantity of temperature sensor tubes | qty | 3 | | | | | |
| Immersion heater rating | kW | 3 | | | | | |
| Immersion heater cable size | mm | 1.5 | | | | | |
| Immersion heater current | A | 13 | | | | | |

* Calculation from test EN 12897.



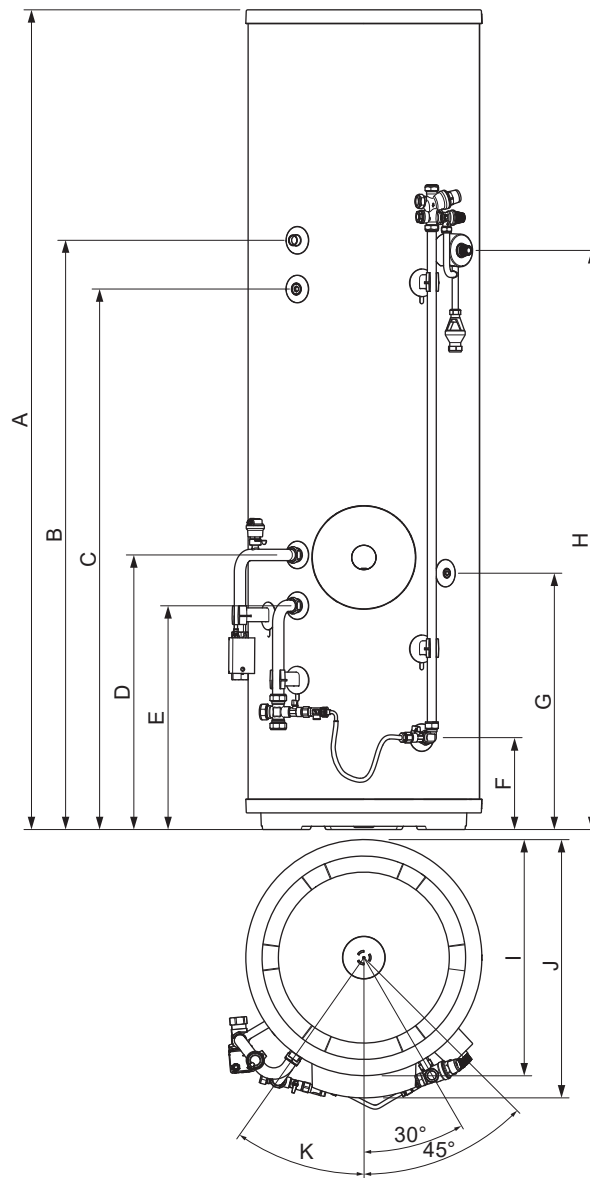

uniSTOR plus

Technical dimensions and clearances



| | A | B | C | D | E | F | G | H | I | J | K |
|-------------------------|---------|---------|---------|-------|-------|-------|-------|---------|-----|-----|-----|
| Unit of measure | mm | | | | | | | | | | deg |
| VIH RW 150/5 C SLPPIAES | 1,519.7 | 1,082 | - | 628.5 | 503.5 | 208.5 | 583.5 | 1,057 | 490 | 520 | 40° |
| VIH RW 175/5 C SLPPIAES | 1,744.7 | 1,214.5 | - | 628.5 | 503.5 | 208.5 | 583.5 | 1,189.5 | 490 | 520 | 40° |
| VIH RW 210/5 C SLPPIAES | 1,999.7 | 1,469.5 | 1,349.5 | 758.5 | 633.5 | 208.5 | 713.5 | 1,444.5 | 490 | 520 | 40° |

uniSTOR accessories

| Accessory | Product name | Description |
|---|-----------------------------------|---|
|  | New purpose-built buffer | The new buffer store solution has been expertly crafted and cleverly designed. It has been optimised to maximise space within your customer's home as a stackable solution. This unique solution can be installed to sit either below or above the cylinder when required as part of the heat pump system. The 30-litre volume is perfect as either a volumiser or a true buffer store. This accessory offers hydraulic decoupling, stores an additional heating capacity to use at peak demands, de-ices the evaporator without the need for back up heating. The buffer provides an additional 30 litres of open system volume to ensure heat pumps run at their peak efficiency. |
|  | External expansion vessel | Included with each uniSTOR pure cylinder, correctly sized to the cylinder capacity, operating at 10 bar pressure. |
|  | Tilt protection | To ensure stability of the cylinder, particularly when the system includes the stackable buffer, a belt has been included with every cylinder, to secure the cylinder to the wall. |
|  | 490mm plinth | A new optional accessory that can be used to elevate the cylinder 200mm to allow for access to pipework and electrical connections. Supplied ready to assemble. Can be fitted to base of either cylinder or buffer. |
|  | Pressure gauge | The pressure gauge provides visibility of the system pressure when the boiler display is remote from the filling loop. Available as an optional accessory |
|  | Titanium immersion heater element | Available to order as an upgrade the immersion heater is more resistant to both chemical attack and scale deposition, increasing both longevity and efficiency. The temperature should never be set higher than 60°C. |
|  | 3-way valve | The 3-way valve is available as an after-market accessory, for use when the heat generator for an existing cylinder is being changed from a boiler, which uses a 2-port safety valve to a heat pump. The valve is designed to return by spring action to the heating port, shutting off the flow to the hot water coil in an emergency situation. |

Hybrid systems



Overview



Vaillant Group takes pride in designing and manufacturing its own range of heat pumps and accessories. We manufacture heat pumps that take thermal energy from the environment and convert that energy to heat. That energy can come from either the air, ground or water, and the only other energy needed is electricity to run the system. All of our heat pumps can be used standalone or as part of a hybrid system (that also contains a gas boiler and may contain solar panels). Heat pumps are suitable for all property types, but are especially energy efficient when fitted to buildings in off-gas areas. Our heat pumps are very flexible and can be fitted in a wide variety of environments. We've even fitted them onto balconies in blocks of flats.

There is 0% VAT on installing energy-saving materials including heat pumps. The 0% VAT will run until March 2027, visit <https://www.gov.uk/guidance/vat-on-energy-saving-materials-and-heating-equipment-notice-7086>.

Scan the QR code for the most popular schematics.

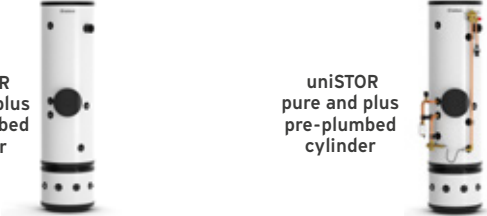

Low carbon solutions from Vaillant

| Renewable technology | Vaillant product |
|---------------------------------|---|
| Air source |  <p>aroTHERM plus aroTHERM split aroCOLLECT flexoTHERM* aroSTOR hot water heat pump</p> |
| Ground source |  <p>flexoTHERM</p> |
| Water source |  <p>flexoTHERM + fluoCOLLECT</p> |
| uniSTOR high recovery cylinders |  <p>uniSTOR pure and plus non-plumbed cylinder uniSTOR pure and plus pre-plumbed cylinder</p> |

Controls

When fitted to a hybrid system, the sensoCOMFORT / RF takes advantage of Vaillant's triVAI[®] intelligent tariff selection tool feature. This tool takes the energy tariff data for each heat source option (gas boiler and electric heat pump) and analyses the Coefficient of Performance (CoP) of the heat pump alongside the efficiency of the boiler. It can then assess this data to independently select the most cost-effective heat source in the system, saving both energy and money.

This smart approach to integrating renewable technology with existing heating systems offers more scope and flexibility for a wider range of properties.

* When using aroCOLLECT

Controls



Controls are an essential part of all heating systems

We always recommend our appliances are fitted with a Vaillant control. Vaillant has a wide range of controls and each uses eBUS, technology that enables each element of a Vaillant system to communicate to ensure it's always working with ultimate efficiency.

Vaillant's controls range from simple analogue controls to app-controlled models that can be integrated with smart home systems and alert you to faults. Every Vaillant heating appliance can be matched with the perfect control to ensure compliance with Boiler Plus legislation.

As well as allowing the user to choose the times their heating and/or hot water switches on or off, controls can set preferred temperature parameters. Controls can also monitor weather conditions in a variety of ways; either by using data from weather forecasts or by using an external sensor. For Vaillant controls, this means the control can take this information and modulate the output of the boiler to deliver the most efficient flow rate to reach the desired temperature. This modulation reduces energy use and carbon outputs that reduce bills while increasing the longevity of the boiler.



The VDE institute is an independent and neutral European technical-scientific association that assesses products and services for smart home security.

All of Vaillant's products have been rigorously tested and have met VDE's strict testing criteria for approval by the Institute. You can therefore rest assured that any data used by Vaillant products is protected and secure.

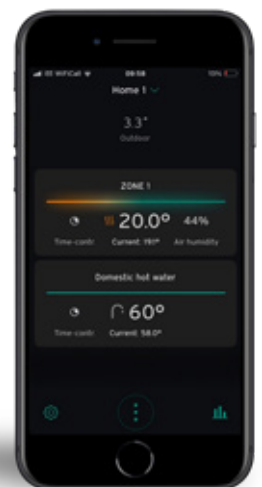

Search for Vaillant on Google Play or the App Store

Types of controls



Sit back, relax and let Vaillant take care of your customer's heating

Vaillant makes a variety of controls to suit your customers needs. These range from basic mechanical timers to sophisticated app-based smart controls.

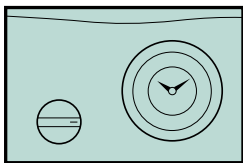

Mechanical timers offer an easy to use, basic solution. Users simply set gears on a dial that turns the boiler on and off at the same time each day.

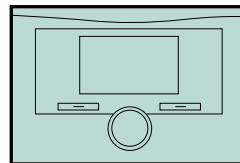

A plug-in control fixes to the front of the boiler allowing your customer to control the heating and hot water functions where the boiler is sited.

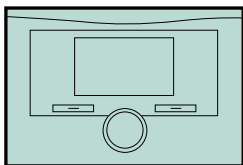

Programmable thermostats are room thermostats that monitor the temperature. As well as having timer programs, they have lower and higher temperature parameters to ensure the temperature doesn't reach an uncomfortable level. This type of control usually also has a holiday function.

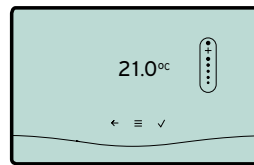

Internet connected controls are controlled remotely and offer the same functionality as programmable room thermostats. These controls have complementary apps* so they can be controlled via mobile devices and connect to smart devices, e.g. Amazon Alexa and Apple HomeKit.

*Simply search for Vaillant.

Google Play



App Store



Scan the QR code for the full range of Vaillant controls



sensoCOMFORT

System controls



Overview

The sensoCOMFORT is Vaillant's latest control for multi-zone heating systems. It's been designed to be simple to install and use, and operates with Vaillant's proprietary eBUS protocol. This ensures all the components of the system can easily communicate with each other to provide optimum system performance. It's perfect for multi-zone gas-fuelled systems, and hybrid, or renewable installations.

The sensoCOMFORT has been designed to be simple to install, with guided commissioning that detects all the components of a system and proposed pre-defined settings.

The sensoCOMFORT is available in a wireless version (RF) that can control up to three heating zones.

Features & benefits



Boiler modulation

eBUS connection allows the boiler to modulate, ensuring peak performance and optimum efficiency for a Vaillant heating system.



Weather compensating

sensoCOMFORT comes with an outdoor sensor which provides an understanding of the thermal behaviour in and around the property and adjusts the flow temperatures to ensure optimal efficiency.



Intuitive Interface

The touch interface provides a simple method of navigating the control to undertake simple tasks.



Energy dashboard

Provides enhanced insight into your customer's heating system performance and energy consumption.



Time programme assistant

Effortlessly set heating programmes within minutes using the time programme assistant.



myVAILLANT App

With a Vaillant internet gateway, the dedicated app can be downloaded and used to manage heating and hot water requirements on the go.



Available wired and wireless

The sensoCOMFORT is available wired and wireless. The wired sensoCOMFORT can support up to 5 heating zones, while the wireless sensoCOMFORT can support up to 3 heating zones. VR 92 thermostats can be added to control individual zones.

VRT 350 / 350F

Load compensating control



Overview

The VRT 350 is designed to be easy to use while maximising efficiency to reduce your energy consumption. It comes with wired or wireless options and it communicates with your customer's boiler to adapt its energy consumption depending on what is required.

Features & benefits



Easy to use

The VRT 350 has a familiar menu structure to make controlling heating systems as simple as possible.



Choose between wired and wireless controls

You can fix the device to the wall or go wireless so your customer can take it anywhere around their home.



Reduce your customer's energy bills

VRT 350's intelligent control means the Vaillant appliance will run in the most efficient way possible, using the minimum energy to get the temperature required and saving your customer money.



Flexible control

The simple menu and override functions allow your customer to quickly boost the heating and hot water whenever needed.



Choose from a range of programmes

The VRT 350's clear, high contrast display has programming options for 7 days, weekdays and weekends or 24-hour time periods, making it easy to create your customer's comfort zone.



Enhanced load compensation

Enhanced load compensation ensures the boiler modulates so it only ever uses the energy it needs.



Service, maintenance and fault indicator

Appliance service, fault and maintenance indication is displayed on the screen.



ErP class V

High ErP performance for up to 3% increased efficiency.

sensoROOM

Wireless thermostat



Overview

The sensoROOM is an easy-to-use, wireless thermostat that may be used as the room thermostat with the myVAILLANT connect internet gateway. Perfect for customers who want a simple thermostat that still offers weather compensation. The sensoROOM will suit any customer looking for a small thermostat to hide and only wish to control their heating through their phone should be pleased with this simple setup.

Features & benefits



Boiler modulation

eBUS connection, via the wireless connection to the Vaillant gateway, allows the boiler to modulate. Ensuring peak performance and optimum efficiency for your customer's home.



Simple installation

Quickly establish the wireless connection to the myVAILLANT connect internet gateway through the myVAILLANT app.



Weather compensating

Optimises system flow temperatures and efficiency based on the temperature outside your home via internet weather data.



Wide range of temperatures for your comfort

The room temperature can be easily adjusted between 5 - 30°C.



ErP class VI (weather compensated via internet data)

When installed with the myVAILLANT connect internet gateway.



App control

Appliance service, fault and maintenance indication is displayed on the screen.

sensoROOM pure

Simple digital thermostat



Overview

The VRT 50/2 (also known as sensoROOM pure) is an easy-to-use digital thermostat that has a contemporary look and familiar dial to provide an easy interface to manage the heating system. Available as a wired room thermostat and utilising Vaillant's eBUS communication protocol, when installed on a Vaillant boiler the control will take full advantage of enhanced load compensation to modulate the Vaillant heating system.

Features & benefits



Boiler modulation

eBUS connection allows the boiler to modulate, ensuring peak performance and optimum efficiency for a Vaillant heating system.



Service, maintenance and fault indicator

Appliance service, fault and maintenance indication is displayed on the screen.



Enhanced load compensation

Uses enhanced load compensation to adjust the output of the Vaillant boiler, ensuring it only uses the energy needed. Weather compensation available when installed with myVAILLANT connect internet gateway.



Simple installation often utilising existing cable

Two core voltage wired connection for simplicity.



Hot water warm start

With the sensoROOM pure, the hot water warm start feature ensures the water is warm allowing for quick availability of hot water through your customer's taps.



Wide range of temperatures for your comfort

The room temperature can be adjusted between 5 - 30°C.



ERP class V or VI

Class V when fitted with timeSWITCH 150 or new ecoTEC plus boiler. Class VI when also fitted with myVAILLANT connect internet gateway which allows for weather compensation.



Inbuilt timer

Unlock inbuilt timer on the new ecoTEC plus boiler facia.

timeSWITCH 150

Mechanical plug-in timer



Overview

Our simple mechanical timer allows your customer to adjust their heating programme by choosing when the system should be switched on and off, and how long the boiler should operate for.

Vaillant traditional mechanical controls have been designed to be easy to use and feel familiar, all whilst automatically offering advanced intelligent functionality compatible with Vaillant combination boiler ranges.

Features & benefits



Easy to use

Sliding tappets and a large analogue clock display for easy setting of your customers time programmes.



Load compensation

Load compensated control when used with a sensoROOM pure, ensuring the perfect temperature for maximum comfort to save money and energy.



24-hour programming

Simple 24-hour timer allows for easy programming, with up to 48 heating on/off times.



Compatible with Vaillant heating systems

Compatible with all Vaillant combination boilers* and the sensoROOM pure digital room thermostat.



ERP class V

When fitted with sensoROOM pure.

* Excluding the new ecoTEC plus boiler range.

myVAILLANT connect

Internet gateway



Overview

myVAILLANT connect internet gateway enables seamless integration of Vaillant appliances with homeowner's smart home systems. The simple one cable connection allows for easy installation with our new ecoTEC plus range of boilers. myVAILLANT connect internet gateway unlocks the full potential and efficiency of the appliance through Vaillant controls meaning more reliable, secure, and stable digital service solutions.

myVAILLANT connect internet gateway is compatible with all eBUS appliances from 2006 onwards including heat pumps. This allows Vaillant to offer a wider range of digital solutions. Not only does the gateway enable app-based control of the heating system, it can also provide opportunity for remote monitoring, remote optimisation and better service assistance to the homeowner and their installation partners.

Features & benefits



A gateway for any system

Suitable for boiler, heat pump and hybrid systems. Can be paired with the sensoCOMFORT, sensoHOME, sensoROOM, sensoROOM pure and VRC 700



Enables remote monitoring

Connect to myVAILLANT Pro Service to offer more services for your customers.



Offer your customer connectivity

Compatible with Amazon Alexa and Apple HomeKit.*



Simple installation

Fits directly below the new ecoTEC plus range with a single CIM cable. Easily connect to the wider range of Vaillant boilers, including the ecoFIT and ecoTEC sustain models for connectivity solutions.



* Smart home integration currently only suitable for single heating zone systems.

Controls compatibility finder

Combination boiler

| Control | | 1 heating zone | 2 heating zones | Multiple heating zones |
|--|--|----------------|-----------------|----------------------------------|
| Weather compensating | | | | |
|  | sensoCOMFORT** | ✓ | ✓ with VR 71 | ✓ up to 5 with VR 71 + VR 70 |
| | sensoCOMFORT RF** | ✓ | ✓ with VR 71 | ✓ up to 3 with VR 71 |
| | VRC 700*** | ✓ | ✓ with VR 70 | ✓ up to 9 with VR 71 + 3 x VR 70 |
| | VRC 700f*** | ✓ | ✓ with VR 70 | ✓ up to 3 with VR 71 |
| | sensoHOME + outdoor sensor* | ✓ | | |
| | sensoROOM + myVAILLANT connect internet gateway | ✓ | | |
| | sensoROOM pure + myVAILLANT connect internet gateway | ✓ | | |
| Load compensating | | | | |
|  | sensoHOME** | ✓ | ✓ with VR 66/2 | |
| | sensoHOME RF | ✓ | | |
| | VRT 350**** | ✓ | ✓ with VR 66/2 | |
| | VRT 350f | ✓ | | |
|  | sensoROOM pure + (timeSWITCH 150 or new ecoTEC) | ✓ | | |

System/Open vent boiler

| Control | | 1 heating zone | 2 heating zones | Multiple heating zones |
|---|--|----------------|-----------------|----------------------------------|
| Weather compensating | | | | |
|  | sensoCOMFORT** | ✓ with VR 71 | ✓ with VR 71 | ✓ up to 5 with VR 71 + VR 70 |
| | sensoCOMFORT RF** | ✓ with VR 71 | ✓ with VR 71 | ✓ up to 3 with VR 71 |
| | VRC 700*** | ✓ with VR 70 | ✓ with VR 70 | ✓ up to 9 with VR 71 + 3 x VR 70 |
| | VRC 700f*** | ✓ with VR 70 | ✓ with VR 70 | ✓ up to 3 with VR 71 |
| | sensoHOME + outdoor sensor* | ✓ with VR 66/2 | | |
| | sensoROOM + myVAILLANT connect internet gateway | ✓ with VR 66/2 | | |
| | sensoROOM pure + myVAILLANT connect internet gateway | ✓ with VR 66/2 | | |
| Load compensating | | | | |
|  | sensoHOME** | ✓ with VR 66/2 | ✓ with VR 66/2 | |
| | sensoHOME RF | ✓ with VR 66/2 | | |
| | VRT 350**** | ✓ with VR 66/2 | ✓ with VR 66/2 | |
| | VRT 350f | ✓ with VR 66/2 | | |
| Basic setup | | | | |
| | timeSWITCH 160 + VRT 15 | ✓ with VR 66/2 | | |

* Outdoor sensor sold separately.

** VR 92(f)s required for additional zones.

*** VR 91(f)s required for additional zones.

**** second VRT 350 required for additional zone.

 Controls with the phone symbol may be controlled on a smart phone when installed with a Vaillant internet gateway. Gateway may need to be purchased separately.

Vaillant flues and accessories

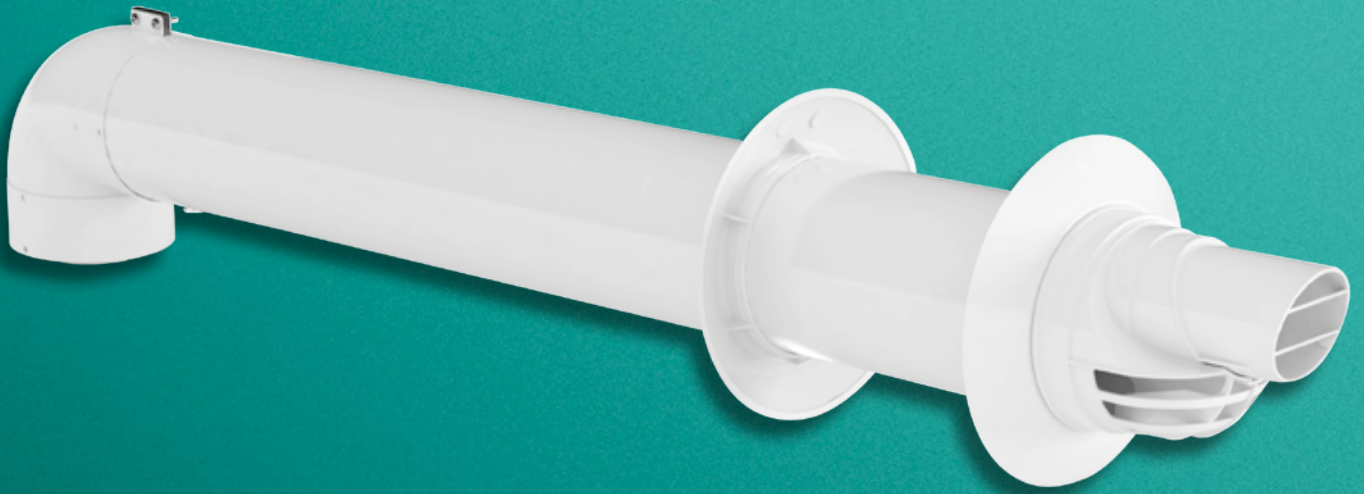

Overview

Vaillant has its own comprehensive range of flues and accessories. Vaillant's high quality flues and accessories must be used with installations of our boilers so that we can guarantee the quality of these items. The use of alternative flues and accessories will invalidate the guarantees of the other system components.

High rise flues

Following an amendment to the Building Regulations (England & Wales) due to the Grenfell disaster, no combustible material can be used for items passing through any external wall in high rise buildings. This effectively means that any boilers that have a polypropylene flue pipe cannot be installed through the wall due to the polypropylene inner exhaust part of the standard flue not being classed as A1 fire resistant to EN 13501-1:2018. In England and Wales, this applies to all floors in a building that is over 18 metres high. It is important to note that in Scotland, this legislation applies to buildings that are more than 11 metres high.

To ensure our customers can comply with this legislation, Vaillant now supplies a High Rise Flue Terminal Kit and an extension kit that are specifically engineered to achieve the fire resistance to meet New Building regulations (Part B) requirements of A1 rating to EN 13501-1:2018. The bespoke High Rise Flue Terminal Kit and extension piece are now available from merchants.

60/100 DN flue range

| Component | Description | Size / Angle | Article number | Part number |
|-----------|--|--------------|----------------|-------------|
| | | | 60/100 DN | 80/125 DN |
| A | Bends (x2) | 45° | 303911 | 303211 |
| B | Elbow | 87° | 303910 | 303210 |
| C | Flue terminal for ridge tile | | 303982 | - |
| D | Extension | 2.0m | 303905 | - |
| | Extension | 4.0m | 0020138174 | - |
| | Extension | 1.0m | 303903 | - |
| | Extension DN 60PP black | 1.0m | 0010039350 | - |
| | Extension DN 60PP white | 1.0m | 0010039352 | - |
| F | Fixing clamp (x5) | | 303821 | 303616 |
| G | Flue support clips (x5) | | 303935 | - |
| H | Black Terminal Kit DN 60 PP | | 0010039348 | - |
| I | Horizontal terminal 60/100 PP | 1.7m | 0010039327 | - |
| J | Horizontal terminal 60/100 PP | 0.7m | 0010039324 | 303209 |
| K | Horizontal terminal 60/100 PP telescopic | 0.4 - 0.7m | 0010039333 | - |
| L | Pitched roof tile flexible black | | 303980 | 303980 |
| M | Pitched weather collar | | 009076 | 009076 |
| N | Deflector Kit DN 60 PP black | | 0010039343 | - |
| O | Deflector Kit DN 60 PP white | | 0010039345 | - |
| P | Direct rear flue kit | | 0010039336 | - |
| R | Roof terminal (black) | | 0020223472 | 0020030797 |
| S | Sliding sleeve | | 303915 | 303215 |
| T | Plume management Kit DN 60 PP black | | 0010039338 | - |
| U | Plume management Kit DN 60 PP white | | 0010039340 | - |
| V | VTK elbow (x2) - (black) | 45° | 0010039358 | - |
| W | VTK elbow (x2) - (white) | 45° | 0010039360 | - |
| X | VTK elbow (black) | 87° | 0010039354 | - |
| Y | VTK elbow (white) | 87° | 0010039356 | - |
| Z | Flat roof weather collar | | 009056 | 009056 |
| | Horizontal Terminal Kit DN60/100 ALU | | 0010035512 | |

Standard top horizontal flue

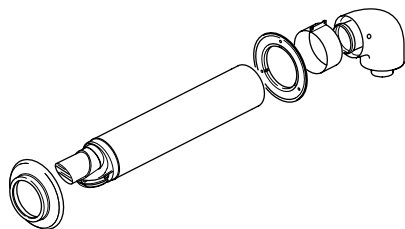

Horizontal telescopic flue

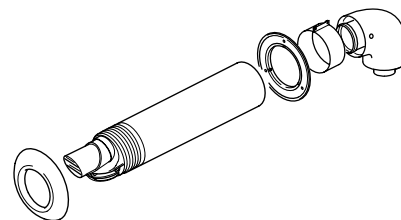

Direct rear flue kit

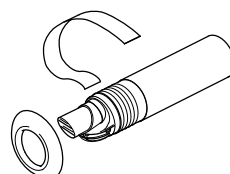

Vertical accessories

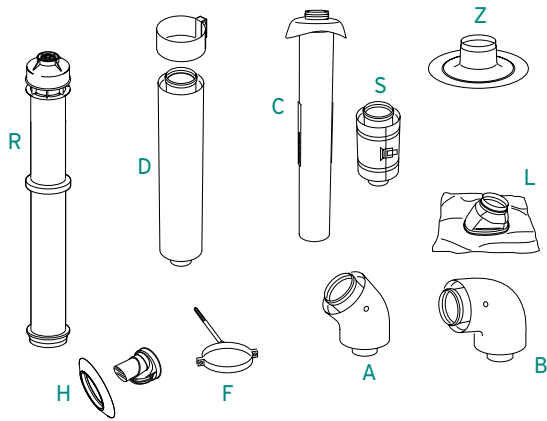

Variable termination kits

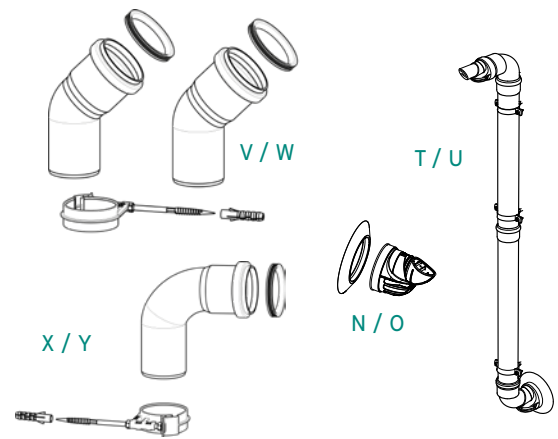

Horizontal flue configurations

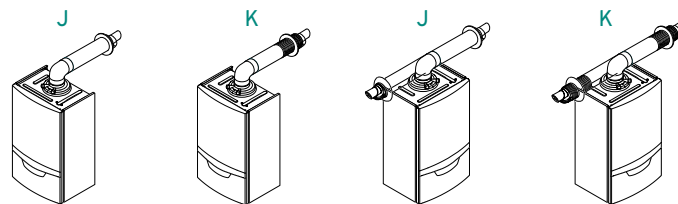
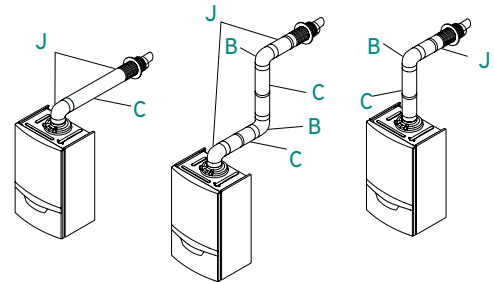
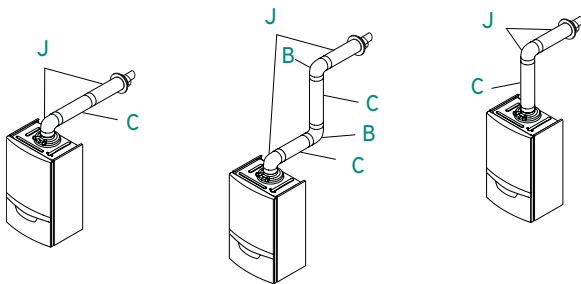
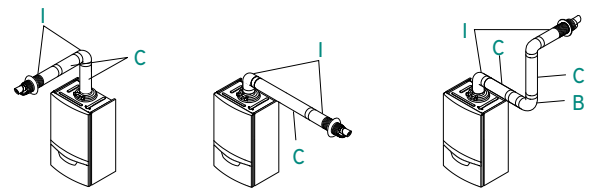
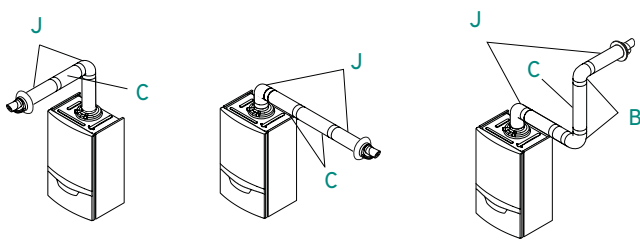

Vertical flue configurations

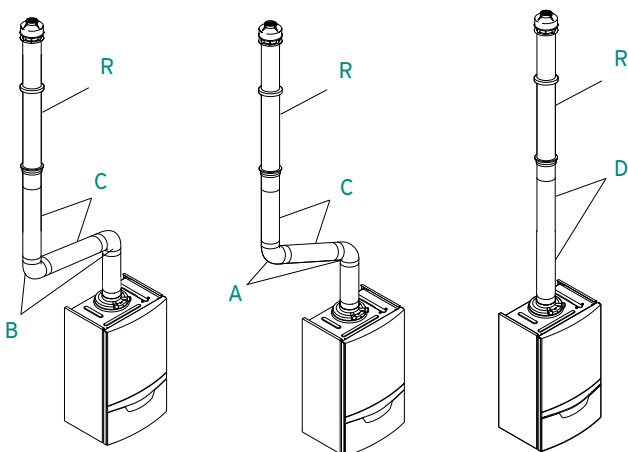

Rear flue configuration (ecoFIT sustain only)

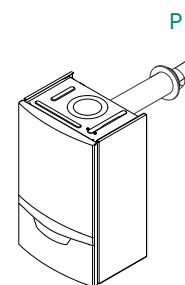

Terminal clearances

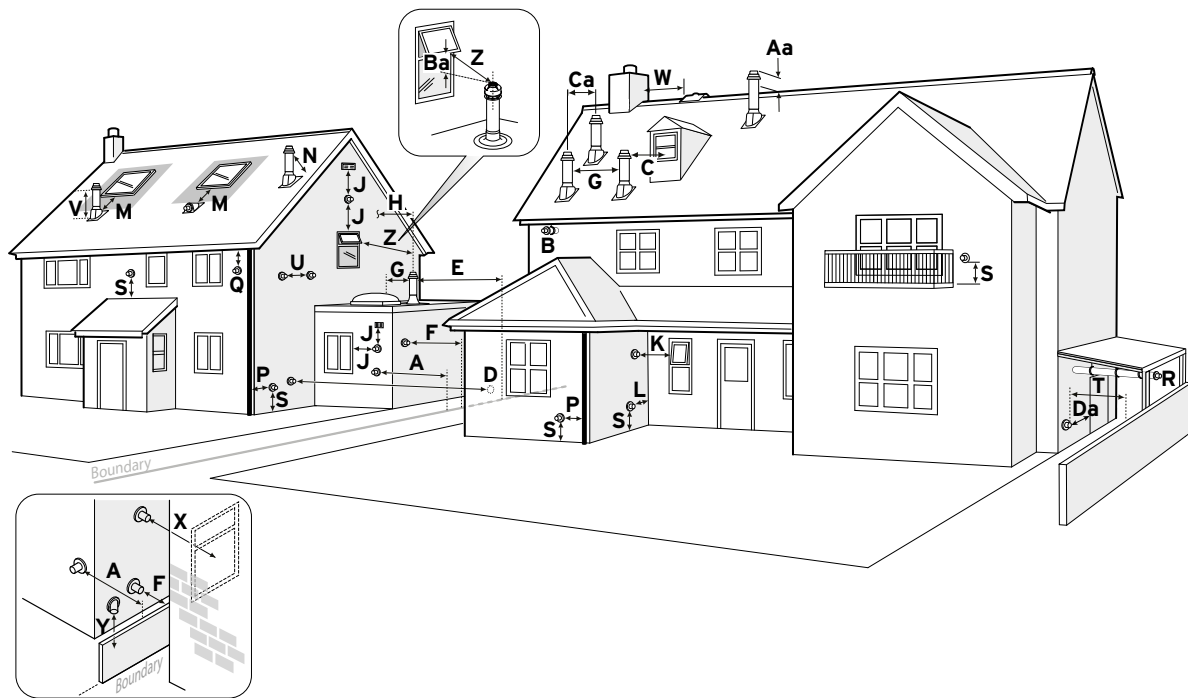

| | | |
|------------------|-------------------|---|
| A | 300 | 300mm adjacent to a boundary. |
| B | 25 ⁽¹⁾ | The dimension below eaves, balconies and car ports can be reduced to 25mm, as long as the flue terminal is extended to clear any overhang. External flue joints must be sealed with a suitable silicon sealant. |
| C | 1500 | 1500mm between a vertical flue terminal and a window or dormer window on a roof. |
| D | 1200 | 1200mm between terminals facing each other. |
| E | 300 | Vertical flue clearance, 300mm adjacent to a boundary line. |
| F ⁽²⁾ | 600 | 600mm distance to a boundary line, unless it will cause a nuisance. BS 5440:Part 1 recommends that care is taken when siting terminal in relation to boundary lines. |
| G | 300 | 300mm minimum clearance from a skylight to a vertical flue or to another adjacent vertical flue. |
| H | 500 1500 | 500mm vertical flue clearance, to non-combustible building material. 1500mm vertical flue clearance to combustible building material. |
| J | 300 | 300mm above, below and either side of an opening door, air vent or opening window. |
| K | 600 | 600mm diagonally to an opening door, air vent or opening window. |
| L ⁽²⁾ | 200 | 200mm to an internal or external corner.* |
| M | 2000 600 | 2000mm below a Velux window. 600mm above or to either side of the Velux window. |
| N | 400 500 | 400mm from a pitched roof. 500mm in regions with heavy snowfall. |
| P | 25 | 25mm from vertical drain pipes and soil pipes. |

* This distance can be reduced to 25mm by using a plume kit or diverter and being angled at 45° to avoid staining.

Note: Terminal must NOT terminate under roof or car port. Car port must have at least two open sides.

(1) There should be no ventilation/opening in the eaves within 300mm distance of the terminal.

| | | |
|------------------|-----------|---|
| Q ⁽¹⁾ | 200 75 | 200mm below eaves. 75mm below gutters, pipe and drains. (see also 'R'). |
| R | 25 | The dimension below eaves, balconies and car ports can be reduced to 25mm, as long as the flue terminal is extended to clear any overhang. External flue joints must be sealed with suitable silicon sealant. |
| S | 300 | 300mm above adjacent ground or balcony. |
| T ⁽²⁾ | 600 | 600mm distance to a surface facing a terminal, unless it will cause a nuisance. BS 5440: Part 1 recommends that care is taken when siting terminals in relation to surfaces facing a terminal. |
| U | 300 | 300mm clearance alongside another terminal. |
| V | 300 | 300mm above roof level. |
| W | 300 | 300mm min to vertical structure on roof, roof vent. |
| X | 2000 | 2000mm min. to opening in adjacent building. |
| Y | 600 | 600mm min. at an angle to a boundary which is not less than 300mm to the terminal. |
| Z | 600 | 600mm min. measured to the nearest corner of the open window. |
| Aa | 300 | No more than 300mm above ridge. |
| Ba | 300 | No less than 300mm below the opening window. |
| Ca | 600 | 600mm between vertical flues. |
| Da | 1200 | From an opening (e.g. door window etc.) in eaves, balconies, car ports and overhangs. |

- (2) These dimensions comply with the building regulations, but they may need to be increased to avoid wall staining and nuisance from pluming depending on site conditions.
- All measurements are the minimum clearances required.
 - Terminals must be positioned so to avoid combustion products entering the building.
 - Support the flue at approximately one metre intervals and at a change of direction, use suitable brackets and fixings.
 - Installations in car ports are not recommended.
 - The flue cannot be lower than 1 metre from the top of a lightwell due to the build up of combustion products.
 - Dimensions from a flue terminal to a fanned air inlet to be determined by the ventilation equipment.
 - The terminal clearances are only applicable where the appliance has been installed, commissioned and maintained in line with the manufacturer's instructions.
 - Always refer to the instructions provided with the boiler.

High rise flues and balcony kits/options

Overview

Building Regulations for high rise applications in England & Wales state that in buildings over 18 metres in height, no combustible material may be used for any item connecting the internal space to the exterior of the property. In Scotland this same regulation applies to buildings over 11 metres in height. That distance applies to all floors of the building not only those over the height restriction. That means any standard flue using polypropylene inner ducts cannot be used and the material used must comply to EN 13501-1:2018 class A1 fire resistance.

Features and benefits



Aluminium inner flue

Complies with EN 13501-1:2018 Class A fire resistance.



Flexible outer collar

Can be fitted from inside the property.



Vaillant system approved

Can be fitted to all Vaillant boilers.

| Article number | Description | Length | Inner material |
|----------------|---|--------|-----------------|
| 0010035512 | High Rise Flue Horizontal Terminal Kit DN60/100 ALU | 0.7m | Aluminium |
| 0010024718 | Balcony flue kit (including elbow) | 0.7m | Stainless steel |

The horizontal terminal is used in standard flue applications where the flue is simply discharged outside the property wall. The Balcony Flue kit is used when the termination requires the addition of a plume management kit to extend the point of flue discharge under a balcony for example.

Why choose Vaillant for your specification?



Overview

Vaillant strives to produce the most reliable and efficient heating appliances in the world. To demonstrate our commitment to this vision, we have recently invested around €54 million in a brand new Research and Development Centre at our headquarters in Remscheid, Germany. With about 700 employees, this is one of the largest international development teams in the heating technology industry.

How we can support you

Industry leading support - Vaillant offers outstanding pre-and post-sales support to help specifiers at each stage of the project.

Total cost of ownership - Vaillant can provide a comprehensive prediction on the cost of ownership, taking into account every detail of installation, including appliance costs, labour rates, spare parts and servicing. Rebates or discounts will also be taken into account.

By analysing this data, Vaillant can predict the whole life cost of ownership and deliver this data to contract customers in the format they require.

Easy asset management - Vaillant Solutions is an online heating assets management tool for landlords to manage the heating appliances in their properties. Crucially, this portal allows users to record system water test results. Access to this data means property managers have the information they need to prevent breakdowns due to poor water quality in the system. Ensuring system water is clean can reduce the chance of future boiler breakdowns by up to 83%.

Key features

- Record system water test results
- Register guarantees
- Create ErP labels
- Access installation and user guides
- View spares catalogue

“Vaillant Solutions allowed us to become more efficient with our day-to-day repairs, with all our order history stored online by address for easy reference. The Vaillant Solutions water testing facility keeps installation standards at a high level and leads to best practice. So there are no different rules for each department which can cause so many problems.”

Jane Duckers, Procurement Officer, Wales & West Housing

For more information visit our website:
www.vaillant-solutions.co.uk
or scan the QR code.



Service and spares support



Spares and support, year after year

Vaillant is committed to responsible spares provision and provides spares for a minimum of 15 years after production ceases. We have a nationwide network of genuine spares stockists and a dedicated spare parts team to help you identify the parts you require.

Vaillant has even developed an app that helps identify spare parts to make ordering easier. Simply search for Vaillant on Google Play or the App Store.

Service you can count on

At Vaillant UK, we invest as much of our resources into our service and support as we do in creating our outstanding heating solutions. So you can rest assured that when you choose a Vaillant product, you will be supported by the best service in the industry.

Vaillant has specialist teams available to support installers and end-users with all enquiries. We pride ourselves on the efficiency of our service departments, supported by online tools that allow our customers to book appointments for our services for added convenience.

Vaillant has over 250 service engineers. This includes the largest specialist fleet of renewable and commercial systems engineers in the UK. With phone operators available 364 days a year, service and support from Vaillant UK is never far away.

Vaillant design services



Unboxing your expertise design?

In the System Sales & Design Team, we offer a specification service to all of our partners to provide indicative heat loss calculations, which can be submitted to us via the QR code below:

Please be aware that this is not a full MIS3005 heat loss design and should be independently checked by yourselves before installation. We aim to have this back to you with 5 days and can offer technical support to you as installers throughout this process.

To find out more contact your Key Account Manager.

Schematics

We have a bank of the most popular schematics available here:



If a particular schematic isn't available for your project, you are able to request a bespoke schematic to assist with the installation. Return time upon request for the schematic is normally 2-4 weeks.



myVAILLANT Pro Service



Support your customers and your business with myVAILLANT Pro Service

Vaillant's eBUS communication technology enables Vaillant appliances to talk to each other and offers data on the performance of the heating system and its components. This technology now means that Vaillant can support your installations further by giving you the tools to offer your customers extra levels of service and support - using myVAILLANT Pro Service which can be used on desktop as well as via an app.

When used with the myVAILLANT connect internet gateway, this solution has the ability to remotely monitor boiler and heat pump installations, with access to detailed performance data, fault code history and offer diagnostic insights - all at the click of a button.

Features & benefits



Improved service efficiency

Be notified immediately of a fault on a customer's appliance, with insights on how to rectify it.



Customer management

Easily manage customers in the secure customer database with quick visibility of appliance model and serial number.



Plannable business

Schedule multiple service and repair visits more efficiently using the failure and spare part insights provided.



Detailed fault and status history information

Time and date stamped service and fault history for each connected appliance and the latest fault information available for all supported appliances.



Diagnostic insights

Data driven insights on failures to aid repairs and spare part identification. myVAILLANT Pro Service uses installer credentials.



Remotely monitor multiple appliances and thermostats

Easily review appliance data points whilst on the move and manage customer's time programs set on their thermostat.



Intelligent repairs

Improve first-time fix rates by knowing which parts you need before you arrive.



Installation and manufacturing date

Complete transparency of the appliance production and installation.

Download the myVAILLANT Pro Service app.

Google Play



App Store



API integration



What's an Application Programming Interface (API)?

An API is a set of rules or protocols that enables software applications to communicate with each other to exchange data, features and functionality. Vaillant Group API Developer Portal allows you to integrate Vaillant APIs with existing software systems. Each industry segment has its own requirements on data interfaces. We have customized solutions for every use case. We offer segment specific API packages that fit to your needs.

Features & benefits



Interoperability

Connect any Vaillant heating system when a myVAILLANT connect internet gateway is installed with a universal language with no specific protocol.



Clear choice for scaling IoT

No requirement for managing multiple manufacturers' portals: everything can be managed from within your existing software and processes.



Total data and development flexibility

Complete flexibility to develop the additional insights from the data provided as required.



For more information or to apply, visit our website: <https://developervillant-group.com/>

Industry leading training for industry leading engineers



Training

At Vaillant, we pride ourselves on being at the forefront of technology and sharing our expertise. That's why we offer a wide range of training courses to help support our installers and their businesses. Whether you're looking for online, practical or accredited courses, we can help find the right training journey for you.

Why train with us?



Nationwide training facilities

We have 8 training facilities across the UK, all of which are equipped with industry-leading products to support your learning.



341 years of expertise

The training team have hundreds of years combined expertise between them, so you can rest assured that you're learning from the best in the business.



Hands-on learning

We strive to deliver a practical approach to training, with live boilers and heat pump installations for you to work on at every one of our centres of excellence.



Courses for all skill levels

We provide training for all skill levels, from apprentices right through to experienced engineers.



Ongoing support

Our training team are committed to sharing knowledge, experience and content to support you throughout your Vaillant training journey.

Scan to learn more about our training courses



Our locations

For more information on our courses or to visit one of our UK Centres of Excellence:

Telephone: 0345 601 8885

or email: training@vaillant.co.uk

Belper

Nottingham Road, Belper, Derbyshire DE56 1JT
Telephone 0345 601 8885

Bristol

Unit 1390, Aztec West, Almondsbury, Bristol
BS32 4RX
Telephone 0345 601 8885

Elland

Unit D1, Lowfields Business Park, Elland,
West Yorkshire HX5 9DG
Telephone 0345 601 8885

Farnborough

Ground Floor (West) Templer, 25 Templer Avenue,
Farnborough Business Park, Farnborough,
Hampshire GU14 6FE
Telephone 0345 601 8885

Glasgow

Maxim 1, 2 Parklands Way, Eurocentral, Glasgow,
Lanarkshire ML1 4WR
Telephone 0345 601 8885

Maidstone

6 Alexander Grove, Kings Hill, West Malling,
Maidstone, Kent ME19 4XR
Telephone 0345 601 8885

Sunderland

Unit 7H Southwick Ind. Est. North Hylton Road
Sunderland SR5 3TX

West Suffolk

Western Way, Bury St Edmunds, IP33 3TB,
University & Professional Development Centre,
West Suffolk College, UK

Aberdeen

Crombie House, 90 Crombie Road, Aberdeen,
AB11, 9QP

Lakes College West Cumbria

Lillyhall Industrial Estate
Hallwood Road
Workington
CA14 4JN



Article numbers

| Article description | Article number |
|-----------------------------------|----------------|
| ecoFIT sustain 25kW (combination) | 0010020392 |
| ecoFIT sustain 30kW (combination) | 0010020393 |
| ecoFIT sustain 30kW (combination) | 0010020394 |
| ecoFIT sustain 15kW (system) | 0010025271 |
| ecoFIT sustain 18kW (system) | 0010025272 |
| ecoFIT sustain 30kW (system) | 0010025273 |
| ecoFIT sustain 15kW (open vent) | 0010025274 |
| ecoFIT sustain 18kW (open vent) | 0010025275 |
| ecoFIT sustain 30kW (open vent) | 0010025276 |
| ecoTEC sustain 24kW (combination) | 0010019980 |
| ecoTEC sustain 28kW (combination) | 0010019981 |
| ecoTEC sustain 34kW (combination) | 0010019982 |
| ecoTEC plus 26kW (combination) | 0010036015 |
| ecoTEC plus 32kW (combination) | 0010036016 |
| ecoTEC plus 36kW (combination) | 0010036017 |
| ecoTEC plus 40kW (combination) | 0010036018 |
| ecoTEC plus 10kW (system) | 0010036009 |
| ecoTEC plus 15kW (system) | 0010036010 |
| ecoTEC plus 20kW (system) | 0010036011 |
| ecoTEC plus 25kW (system) | 0010036012 |
| ecoTEC plus 30kW (system) | 0010036013 |
| ecoTEC plus 35kW (system) | 0010036014 |

| Article description | Article number |
|----------------------------|----------------|
| flexoTHERM 5kW | 0020257358 |
| flexoTHERM 8kW | 0020257359 |
| flexoTHERM 11kW | 0020257360 |
| flexoTHERM 15kW (400v) | 0020257361 |
| flexoTHERM 19kW (400v) | 0020257362 |
| flexoTHERM 5kW (400v) | 0020257363 |
| flexoTHERM 8kW (400v) | 0020257364 |
| flexoTHERM 11kW (400v) | 0020257365 |
| aroCOLLECT up to 11kW pack | 0020221335 |
| aroCOLLECT up to 19kW pack | 0020221336 |
| aroTHERM plus 3.5kW | 0010037211 |
| aroTHERM plus 5kW | 0010037212 |
| aroTHERM plus 7kW | 0010037213 |
| aroTHERM plus 10kW | 0010037214 |
| aroTHERM plus 12kW | 0010037215 |
| aroTHERM plus 10kW (400v) | 0010048453 |
| aroTHERM plus 12kW (400v) | 0010048454 |

| Article description | Article number |
|--|----------------|
| aroTHERM plus 3.5kW + uniTOWER | 0010037201 |
| aroTHERM plus 7kW + uniTOWER | 0010037203 |
| aroTHERM plus 10kW + uniTOWER | 0010037204 |
| aroTHERM plus 12kW + uniTOWER | 0010037205 |
| aroTHERM plus 3.5kW + hydraulic module | 0010037206 |
| aroTHERM plus 5kW + hydraulic module | 0010037207 |
| aroTHERM plus 7kW + hydraulic module | 0010037208 |
| aroTHERM plus 10kW + hydraulic module | 0010037209 |
| aroTHERM plus 12kW + hydraulic module | 0010037210 |
| aroTHERM plus 3.5kW Hybrid for VL Blr | 0010037934 |
| aroTHERM plus 5kW Hybrid for VL Blr | 0010037935 |
| aroTHERM plus 7kW Hybrid for VL Blr | 0010037936 |
| aroTHERM plus 10kW Hybrid for VL Blr | 0010037937 |
| aroTHERM plus 12kW Hybrid for VL Blr | 0010037938 |
| aroTHERM plus 3.5kW Hybrid-Incumbent Blr | 0010037939 |
| aroTHERM plus 5kW Hybrid - Incumbent Blr | 0010037940 |
| aroTHERM plus 7kW Hybrid - Incumbent Blr | 0010037941 |
| aroTHERM plus 10kW Hybrid-Incumbent Blr | 0010037942 |
| aroTHERM plus 12kW Hybrid-Incumbent Blr | 0010037943 |
| aroTHERM split 3.5kW | 0010031875 |
| aroTHERM split 5kW | 0010031876 |
| aroTHERM split 7kW | 0010031877 |
| aroTHERM split 10kW | 0010031878 |
| aroTHERM split 12kW | 0010031879 |
| aroSTOR 200ltr | 0010031862 |
| aroSTOR 270ltr | 0010031863 |

| Article description | Article number |
|--|----------------|
| uniSTOR pure 90l slimline non-plumbed | 8000011504 |
| uniSTOR pure 150l slimline non-plumbed | 8000011505 |
| uniSTOR pure 175l slimline non-plumbed | 8000011506 |
| uniSTOR pure 210l slimline non-plumbed | 8000011507 |
| uniSTOR plus 150l slimline non-plumbed | 8000011633 |
| uniSTOR plus 175l slimline non-plumbed | 8000011634 |
| uniSTOR plus 210l slimline non-plumbed | 8000011635 |
| uniSTOR plus 150l slimline pre-plumbed | 8000011620 |
| uniSTOR plus 175l slimline pre-plumbed | 8000011621 |
| uniSTOR plus 210l slimline pre-plumbed | 8000011622 |
| uniSTOR pure 90l slimline pre-plumbed | 8000011508 |
| uniSTOR pure 150l slimline pre-plumbed | 8000011509 |
| uniSTOR pure 175l slimline pre-plumbed | 8000011510 |
| uniSTOR pure 210l slimline pre-plumbed | 8000011511 |
| Buffer | 8000011534 |

| Cylinder accessories | Article number |
|-----------------------------------|----------------|
| Plinth 490mm | 8000011653 |
| Titanium Heater 3kW Slimline D490 | 8000011661 |
| Pressure gauge | 8000011817 |
| 3-way valve | 0020236141 |

| Article description | Article number |
|--|----------------|
| Connected products | |
| myVAILLANT connect internet gateway + VRA 42 | 0010038367 |
| VRA 42 | 0010040289 |
| Weather compensating controls | |
| sensoCOMFORT | 0010036819 |
| sensoCOMFORT RF | 0010036820 |
| VRT 350 | 0020124475 |
| VRT 350f | 0020124482 |
| sensoROOM | 0010035748 |
| sensoROOM pure | 0010038663 |
| timeSWITCH 150 | 0020116882 |
| VR 92 | 0020260925 |
| VR 92f | 0020260940 |
| VRC 700 | 0020236291 |
| VRC 700f | 0020259829 |
| VR 91 | 0020171334 |
| VR 91f | 0020231566 |
| Wiring centres | |
| VR 70 | 0020184844 |
| VR 71 | 0020184847 |
| Accessories | |
| H bracket | 0010048535 |
| VRC 693 | 000693 |
| VR 20 | 0020028537 |

Contacts

Technical enquiries

If you have a technical query, you can contact us by phone or email.

Phone: **0344 693 3133**

Email: **technical@vaillant.co.uk**

Training

For information on training centres and courses in your area.

Phone: **0345 601 8885**

Email: **training.enquiriesuk@vaillant-group.com**

System Sales and Design

Our expert System Sales and Design team provides installers and specifiers with comprehensive heating system design support on their renewable and commercial boiler projects.

Phone: **0330 123 1767**

General enquiries

If you are unsure of who you need to speak to or you have a general enquiry, our friendly reception staff will happily point you in the right direction.

Phone: **0345 602 2922**

Multi-build Design Team

Our multi-build design team are here to assist with your larger new-build gas and heat pump projects.

Our knowledgeable team will offer a solution to get your project off the ground.

Phone: **0330 1231 767**

Email: **vaillant-design@vaillant.co.uk**

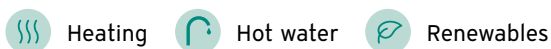

Vaillant Group UK Ltd.

Nottingham Road, Belper, Derbyshire DE56 1JT

Telephone 0345 602 2922

professional.vaillant.co.uk

info@vaillant.co.uk

Search for VaillantUK on