

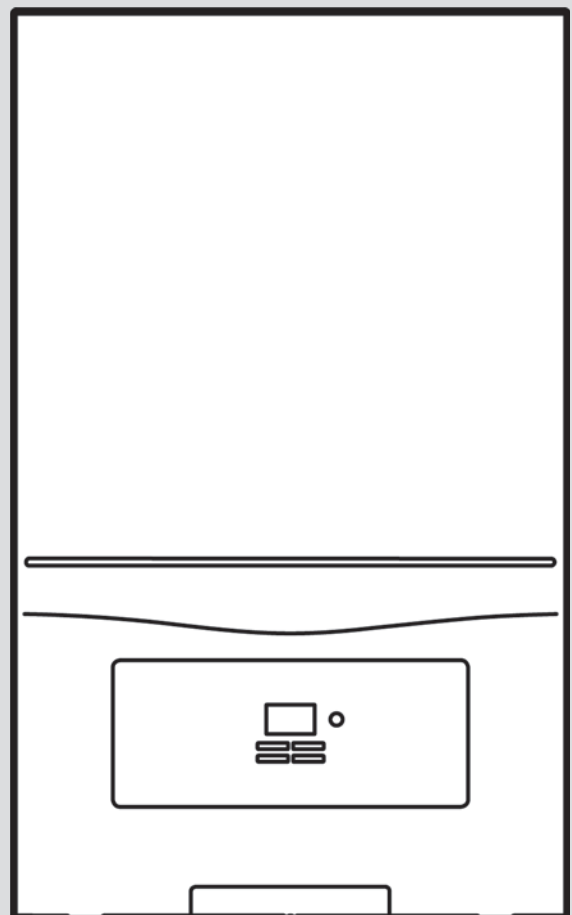

ecoTEC sustain

24, 28, 34



Installation and maintenance instructions

Contents

1	Safety	4	9	Start-up	29
1.1	Intended use	4	9.1	Carrying out the initial start-up	29
1.2	Qualification	4	9.2	Checking and treating the heating water/filling and supplementary water	29
1.3	General safety information	4	9.3	Filling the condensate siphon	30
1.4	Regulations (directives, laws, standards)	6	9.4	Switching the product on and off	30
1.5	List of relevant standards for Great Britain and Ireland	6	9.5	Preventing low water pressure	30
2	Guarantee and Customer Service	7	9.6	Flushing the heating installation for the first time ("cold")	30
3	Technical data	8	9.7	Filling and purging the heating installation	30
4	Notes on the documentation	11	9.8	Filling the hot water circuit	31
5	Product description	11	9.9	Checking the gas setting	31
5.1	CE marking	11	9.10	Thoroughly flushing the heating installation ("hot")	32
5.2	Energy Saving Trust Endorsed Products	11	9.11	Checking leak-tightness	33
5.3	Information on the identification plate	11	10	Adapting the unit to the heating installation	33
5.4	Serial number	12	10.1	Activating diagnostics codes	33
5.5	Product design	12	10.2	Burner anti-cycling time	33
5.6	Safety Devices	12	10.3	Setting the maximum heating output	34
6	Set-up	13	10.4	Setting the maintenance interval	34
6.1	Checking the scope of delivery	13	10.5	Setting the pump output	34
6.2	Dimensions	13	10.6	Setting the bypass	34
6.3	Installation site	14	10.7	Setting the domestic hot water temperature	35
6.4	Minimum clearances	14	11	Handing over to the end user	35
6.5	Compartment Ventilation	14	12	Inspection and maintenance	36
6.6	Air/flue pipe	14	12.1	Complete Service Interval Record section	36
6.7	Using the installation template	18	12.2	Using original seals	36
6.8	Wall-mounting the product	18	12.3	Inspection and maintenance	36
6.9	Removing/installing the front casing	18	12.4	Preparing the maintenance work	36
6.10	Removing/installing the side section	19	12.5	Checking the CO ₂ content	36
7	Installation	20	12.6	Setting the CO ₂ content	37
7.1	Preparing for installation	20	12.7	Removing the compact thermal module	37
7.2	Information on the gas group	20	12.8	Cleaning the heat exchanger	38
7.3	Purging the liquid gas tank	20	12.9	Checking the burner	38
7.4	Using the correct gas type	20	12.10	Cleaning the condensate siphon	39
7.5	Descaling the water	20	12.11	Cleaning the strainer in the cold water inlet	39
7.6	Gas family check	20	12.12	Cleaning the heating filter	39
7.7	Gas and water connections	20	12.13	Installing the compact thermal module	39
7.8	Connecting the condensate discharge pipe	20	12.14	Draining the product	40
7.9	Installing the discharge pipe on the expansion relief valve	23	12.15	Checking the admission pressure of the expansion vessel	40
7.10	Flue installation	23	12.16	Completing inspection and maintenance work	40
7.11	Electrical installation	23	12.17	Checking the product for leak-tightness	40
8	Operation	27	13	Troubleshooting	40
8.1	Operating concept	27	13.1	Checking service messages	40
8.2	Installer level overview	27	13.2	Rectifying faults	40
8.3	Calling up the installer level	27	13.3	Calling up the fault memory	40
8.4	Using diagnostics codes	27	13.4	Deleting the fault memory	41
8.5	Displaying the status codes	27	13.5	Resetting parameters to factory settings	41
8.6	Using check programmes	27	13.6	Preparing the repair work	41
			13.7	Replacing defective components	41
			13.8	Completing repair work	44
			14	Decommissioning	44
			14.1	Permanently decommissioning the product	44

15	Recycling and disposal.....	44
Appendix	45
A	Inspection and maintenance work.....	45
B	Check programmes – Overview	46
C	Overview of diagnostics codes.....	46
D	Status codes – Overview	50
E	Overview of fault codes	51
F	Wiring diagrams.....	53
F.1	Wiring diagram.....	53
F.2	Wiring diagram.....	54
G	Commissioning Checklist.....	55
H	Commissioning Flow Chart	59
Index	60



1 Safety

1.1 Intended use

The product is intended as a heat generator for sealed heating installations and for domestic hot water generation.

Improper use of any kind is prohibited.

Intended use also includes the following:

- use of the product only in mobile homes that are made, transported once and permanently situated in Great Britain and Ireland. After the transportation of the mobile home to its destination the complete product must be checked for leak-tightness again
- validity of the product only for Great Britain and Ireland and for the gas types in Great Britain and Ireland as listed on the data plate
- Installing and operating the product only in conjunction with accessories for the air/flue pipe which are listed in the other applicable documents and comply with the type of unit
- Using the product while observing the accompanying operating, installation and maintenance instructions for the product along with all other components of the installation
- Installing and setting up the product while observing the product and system approval
- Observing all inspection and maintenance conditions listed in the instructions
- Installing while observing the IP code

The following is classed as improper use:

- Using the product in vehicles, such as mobile homes or caravans. Units that are not classed as vehicles are those that are installed in a fixed and permanent location (known as "fixed installation").
- Any direct use in industrial or commercial processes
- Any use other than those described in these instructions and any use that goes beyond what is described here

1.2 Qualification

The person carrying out the work described here must have completed professional training. The competent person must demonstrably have all of the knowledge, skills and capabilities that are required in order to carry out the work mentioned below.

The following work must only be carried out by competent persons who are sufficiently qualified to do so:

- Set-up
- Dismantling
- Installation
- Start-up
- Inspection and maintenance
- Repair
- Decommissioning
- ▶ Proceed in accordance with current technology.
- ▶ Use the correct tool.

The above-mentioned work must always only be carried out by persons with sufficient qualifications.

This product can be used by children over eight years old and also by persons with limited physical, sensory or mental capabilities or insufficient experience and/or knowledge if they are supervised or have been provided with instructions on how to safely use the product, and they understand the risks resulting from using the product. Children must not play with the product. Cleaning and user maintenance work must not be carried out by children unless they are supervised.

1.3 General safety information

The following sections convey important safety information. It is essential to read and observe this information in order to prevent risk of death, risk of injury, material damage or environmental damage.

1.3.1 Gas

If you smell gas:

- ▶ Avoid rooms that smell of gas.
- ▶ If possible, open doors and windows fully and ensure adequate ventilation.
- ▶ Do not use naked flames (e.g. lighters, matches).
- ▶ Do not smoke.





- ▶ Do not use any electrical switches, mains plugs, doorbells, telephones or other communication systems in the building.
- ▶ Close the emergency control valve or the main isolator.
- ▶ If possible, close the gas stopcock on the product.
- ▶ Warn other occupants in the building by yelling or banging on doors or walls.
- ▶ Leave the building immediately and ensure that others do not enter the building.
- ▶ Notify the gas supply company or the Emergency Service Provider +44 (0) 800 111999 by telephone once you are outside of the building.

1.3.2 Flue gas

Flue gases may cause poisoning, while hot flue gases may also cause burns. Flue gases must therefore never be allowed to escape uncontrollably.

What to do if you smell flue gas in the property:

- ▶ Open all accessible doors and windows fully to provide ventilation.
- ▶ Switch off the product.
- ▶ Check the flue gas routes in the product and the flue gas diversions.

To prevent flue gas exit:

- ▶ Only operate the product if the air/flue pipe has been completely installed.
- ▶ With the exception of short periods for testing purposes, only operate the product when the front casing is installed and closed.
- ▶ If you operate the product with an empty condensate trap / siphon, then flue gas may escape into the room air.
- ▶ In order to operate the product, ensure that the condensate trap / siphon is always full.

To ensure that the seals are not damaged:

- ▶ Instead of grease, use only water or commercially available soft soap to aid installation.

1.3.3 Electricity

The power supply terminals L and N remain live even if the unit main switch is switched off.

To prevent electric shocks, proceed as follows before working on the product:

- ▶ Disconnect the product from the power supply by switching off all power supplies at all poles (electrical partition with a contact gap of at least 3 mm, e.g. fuse or circuit breaker) or remove the mains plug (if present).
- ▶ Secure against being switched back on again.
- ▶ Wait at least three minutes until the condensers have discharged.
- ▶ Check that there is no voltage.

1.3.4 Weight

To prevent injuries when transporting the product:

- ▶ Make sure that the product is transported by at least two people.

1.3.5 Explosive and flammable substances

To prevent explosions and fire:

- ▶ Do not use the product in storage rooms that contain explosive or flammable substances (such as petrol, paper or paint).

1.3.6 High temperatures

To prevent burns:

- ▶ Only carry out work on components once they have cooled down.

To prevent material damage that is caused by heat transfer:

- ▶ Only solder connectors if the connectors are not yet screwed to the service valves.

1.3.7 Heating water

Both unsuitable heating water and air in the heating water may cause material damage to the product and in the heat generator circuit.



- ▶ Check the quality of the heating water. (→ Page 29)
- ▶ If you use non-diffusion-tight plastic pipes in the heating installation, ensure that no air gets into the heat generator circuit.

1.3.8 Neutralisation device

To prevent contamination of the waste water:

- ▶ Check whether a neutralising unit must be installed in accordance with national regulations.



- 
- 
- ▶ Observe local regulations on neutralising condensate.

1.3.9 Frost

To prevent material damage:

- ▶ Do not install the product in rooms prone to frost.

1.3.10 Safety devices

- ▶ Install the necessary safety devices in the installation.

1.3.11 Risk of death from leaks if the product is installed below ground level

Liquid gas accumulates at floor level. If the product is installed below ground level, liquid gas may accumulate at floor level if there are any leaks. In this case, there is a risk of explosion.

- ▶ Make sure that liquid gas cannot escape from the product or the gas pipe under any circumstances.

1.4 Regulations (directives, laws, standards)

- ▶ Observe the national regulations, standards, directives, ordinances and laws.

1.5 List of relevant standards for Great Britain and Ireland

- ▶ Observe the national regulations, standards, directives, ordinances and laws.



You can find a list of relevant standards at:
<https://www.vaillant.co.uk/standards>

Guarantee Registration

Thank you for installing a new Vaillant appliance in your home. Vaillant appliances are manufactured to the very highest standard so we are pleased to offer our customers a comprehensive guarantee.

To maintain your guarantee, the boiler must be serviced annually by a competent person who holds the required qualifications in accordance with the rules in force of the country where the product is installed and in accordance with the manufactures recommendations.

We recommend you complete your guarantee registration as soon as possible.

Sales Support:

Telephone: 0345 602 0262

Technical Enquiries:

Telephone: 0344 693 3133

Email: technical@vaillant.co.uk

General Enquiries:

Telephone: 0345 602 2922

Training Enquiries:

Telephone: 0345 601 8885

Email: training.enquiriesuk@vaillant-group.com

Spares Enquiries:

Telephone: 01773 596 615

To register your Vaillant appliance visit:

<https://self-service.vaillant.co.uk/warranty-registration>



Vaillant is a licensed member of the Benchmark Scheme. Benchmark places responsibilities on both manufacturers and installers. The purpose is to ensure that customers are provided with the correct equipment for their needs, that it is installed, commissioned and serviced in accordance with the manufacturer's instructions by a competent person approved at the time by the Health and Safety Executive and that it meets the requirements of the appropriate Building Regulations. The Benchmark Checklist can be used to demonstrate compliance with Building Regulations and should be provided to the customer for future reference.

Installers are required to carry out installation, commissioning and servicing work in accordance with the Benchmark Code of Practice which is available from the Heating and Hotwater Industry Council who manage and promote the Scheme. Benchmark is managed and promoted by the Heating and Hotwater Industry Council.



3 Technical data

Technical data – General

	VUW 246/7-2 (H-GB)	VUW 286/7-2 (H-GB)	VUW 346/7-2 (H-GB)
Gas category	II2H3P	II2H3P	II2H3P
Diameter of the gas pipe	1/2"	1/2"	1/2"
Diameter of the heating pipe	3/4"	3/4"	3/4"
Diameter of the domestic hot water pipe	3/4"	3/4"	3/4"
Expansion relief valve connector (min.)	15.0 mm	15.0 mm	15.0 mm
Condensate discharge pipe (min.)	21.5 mm	21.5 mm	21.5 mm
G20 gas supply pressure	2.0 kPa (20.0 mbar)	2.0 kPa (20.0 mbar)	2.0 kPa (20.0 mbar)
G31 gas supply pressure	3.7 kPa (37.0 mbar)	3.7 kPa (37.0 mbar)	3.7 kPa (37.0 mbar)
Gas flow at P max. – domestic hot water (G20)	2.6 m ³ /h	3.0 m ³ /h	3.7 m ³ /h
CE number (PIN)	CE-0063CR3775	CE-0063CR3775	CE-0063CR3775
SAP 2009/2012 annual efficiency (%)	89.2	89.1	89.2
Flue gas mass flow rate in heating mode at P min.	3.1 g/s	3.6 g/s	4.1 g/s
Flue gas mass flow rate in heating mode at P max.	8.9 g/s	8.9 g/s	8.9 g/s
Flue gas mass flow rate in domestic hot water mode at P max.	11.6 g/s	13.6 g/s	16.5 g/s
Released system types	C13, C33, C43, C53	C13, C33, C43, C53	C13, C33, C43, C53
Min. flue gas temperature	44 °C	41 °C	43 °C
Max. flue gas temperature	85 °C	95 °C	99 °C
Nominal efficiency at 80/60 °C	98.9 %	98.9 %	98.9 %
Nominal efficiency at 50/30 °C	107.5 %	107.3 %	106.6 %
Partial load nominal efficiency (30%)	107.4 %	108.0 %	108.1 %
NOx class	6	6	6
Product dimensions, width	440 mm	440 mm	440 mm
Product dimensions, depth	338 mm	338 mm	338 mm
Product dimensions, height	720 mm	720 mm	720 mm
Net weight	30.8 kg	30.8 kg	32.8 kg
Weight when filled with water	33.5 kg	33.5 kg	35.9 kg

Technical data – G20

	VUW 246/7-2 (H-GB)	VUW 286/7-2 (H-GB)	VUW 346/7-2 (H-GB)
Effective output range (P) at 50/30 °C	7.0 to 20.1 kW	8.0 to 20.1 kW	9.1 to 19.9 kW
Effective output range (P) at 80/60 °C	6.4 to 18.5 kW	7.4 to 18.5 kW	8.4 to 18.5 kW
Heat output range – domestic hot water or cylinder reheating (P)	6.6 to 24.3 kW	7.5 to 28.1 kW	8.4 to 34.0 kW
Maximum heat input – heating (Q max.)	18.7 kW	18.7 kW	18.7 kW
Minimum heat input – heating (Q min.)	6.6 kW	7.6 kW	8.6 kW
Maximum heat input – Domestic hot water or cylinder reheating (Q max.)	24.4 kW	28.5 kW	34.6 kW
Minimum heat input – Domestic hot water or cylinder reheating (Q min.)	6.6 kW	7.6 kW	8.6 kW

Technical data – G31

	VUW 246/7-2 (H-GB)	VUW 286/7-2 (H-GB)	VUW 346/7-2 (H-GB)
Effective output range (P) at 50/30 °C	7.0 to 20.1 kW	8.0 to 20.1 kW	9.1 to 19.9 kW
Effective output range (P) at 80/60 °C	6.4 to 18.5 kW	7.4 to 18.5 kW	8.4 to 18.5 kW
Heat output range – domestic hot water or cylinder reheating (P)	6.6 to 24.3 kW	7.5 to 28.1 kW	8.4 to 34.0 kW
Maximum heat input – heating (Q max.)	18.7 kW	18.7 kW	18.7 kW
Minimum heat input – heating (Q min.)	6.6 kW	7.6 kW	8.6 kW
Maximum heat input – Domestic hot water or cylinder reheating (Q max.)	24.4 kW	28.5 kW	34.6 kW
Minimum heat input – Domestic hot water or cylinder reheating (Q min.)	6.6 kW	7.6 kW	8.6 kW

Technical data – Heating

	VUW 246/7-2 (H-GB)	VUW 286/7-2 (H-GB)	VUW 346/7-2 (H-GB)
Maximum flow temperature	85 °C	85 °C	85 °C
Max. flow temperature adjustment range (factory setting: 75 °C)	30 to 80 °C	30 to 80 °C	30 to 80 °C
Safety discharge of expansion relief valve	0.3 MPa (3.0 bar)	0.3 MPa (3.0 bar)	0.3 MPa (3.0 bar)
Maximum operating pressure	0.25 MPa (2.50 bar)	0.25 MPa (2.50 bar)	0.25 MPa (2.50 bar)
Nominal water flow ($\Delta T = 20$ K)	797 l/h	797 l/h	797 l/h
Remaining pump head (at nominal circulation water volume), bypass closed	0.043 MPa (0.430 bar)	0.043 MPa (0.430 bar)	0.055 MPa (0.550 bar)
Remaining pump head (at nominal circulation water volume), bypass in factory-set position	0.025 MPa (0.250 bar)	0.025 MPa (0.250 bar)	0.025 MPa (0.250 bar)
Approximate value for the condensate volume (pH value between 3.5 and 4.0) at 50/30 °C	1.87 l/h	1.87 l/h	1.87 l/h
Expansion vessel capacity	8.0 l	8.0 l	8.0 l
Maximum heat output (factory setting – d.00)	Auto	Auto	Auto

Technical data – Domestic hot water

	VUW 246/7-2 (H-GB)	VUW 286/7-2 (H-GB)	VUW 346/7-2 (H-GB)
Minimum water flow	1.7 l/min	1.7 l/min	1.7 l/min
Specific flow rate (D) ($\Delta T = 30$ K) in accordance with EN 13203	11.5 l/min	13.5 l/min	16.5 l/min
Specific flow rate ($\Delta T = 35$ K)	9.9 l/min	11.6 l/min	14.1 l/min
Minimum permissible pressure	0.03 MPa (0.30 bar)	0.03 MPa (0.30 bar)	0.03 MPa (0.30 bar)
Maximum permissible pressure (PMW)	1 MPa (10 bar)	1 MPa (10 bar)	1 MPa (10 bar)
Temperature range	35 to 60 °C	35 to 60 °C	35 to 60 °C
Flow rate limiter for cold water	8.0 l/min	10.0 l/min	12.0 l/min
Hot water comfort in accordance with the standard EN 13203	**	**	**

Technical data – Electrics

	VUW 246/7-2 (H-GB)	VUW 286/7-2 (H-GB)	VUW 346/7-2 (H-GB)
Electric connection	– 230 V – 50 Hz	– 230 V – 50 Hz	– 230 V – 50 Hz
Built-in fuse (slow-blow)	T2/2A,250V	T2/2A,250V	T2/2A,250V

	VUW 246/7-2 (H-GB)	VUW 286/7-2 (H-GB)	VUW 346/7-2 (H-GB)
Max. electrical power consumption	100 W	110 W	115 W
Standby electrical power consumption	1.6 W	1.8 W	2.6 W
Level of protection	IPX4D	IPX4D	IPX4D
Permissible connected voltage	190 to 253 V	190 to 253 V	190 to 253 V

4 Notes on the documentation

- ▶ Always observe all operating instructions enclosed with the installation components.
- ▶ Store these instructions and all other applicable documents for further use.

These instructions apply only to:

Product article number

ecoTEC sustain 24	VUW 246/7-2 (H-GB)	0010019980
ecoTEC sustain 28	VUW 286/7-2 (H-GB)	0010019981
ecoTEC sustain 34	VUW 346/7-2 (H-GB)	0010019982

Gas Council Numbers

ecoTEC sustain 24	VUW 246/7-2 (H-GB)	47-044-79
ecoTEC sustain 28	VUW 286/7-2 (H-GB)	47-044-80
ecoTEC sustain 34	VUW 346/7-2 (H-GB)	47-044-81

5 Product description

5.1 CE marking



The CE marking shows that the products comply with the basic requirements of the applicable directives as stated on the declaration of conformity.

The declaration of conformity can be viewed at the manufacturer's site.

5.2 Energy Saving Trust Endorsed Products



Only the most energy efficient products can carry the 'Energy Saving Trust Endorsed Product' landmark making it easy for consumers to choose products that have met strict energy performance criteria.

Available for: Boilers, Heating controls and chemical inhibitors, the Energy Saving Trust endorsed product landmark gives consumers confidence that a product will cost less to run, help lower energy bills and reduce carbon emissions.

About the Energy Saving Trust

Energy Saving Trust is an independent and impartial organisation that provides trusted energy saving advice to empower millions of people to lead affordable, low energy lifestyles. For more information visit energysavingtrust.org.uk

5.3 Information on the identification plate

The identification plate is mounted on the underside of the product in the factory.

The identification plate keeps record of the country in which the product is to be installed.

Information on the identification plate	Meaning
Condensing technology	Efficiency class of the boiler in accordance with EC Directive 92/42/EEC
Serial number	For quality control purposes; 3rd and 4th digits = year of production For quality control purposes; 5th and 6th digits = week of production For identification purposes; 7th to 16th digits = product article number For quality control purposes; 17th to 20th digits = place of manufacture
... ecoTEC ...	Product designation
Cat.	Approved gas category
Type: Xx3(x)	Permissible flue gas connections
2H / 2E / 3P / 2K...	Gas group and gas connection pressure as set at the factory
Tmax	Max. flow temperature
PMS	Maximum water pressure in heating mode
NOx	NOx class for the product
V Hz	Electric connection
W	Max. electrical power consumption
IP	Protection class
Code (DSN)	Specific product code
	Heating mode
Qn	Nominal heating load range in heating mode
Pn	Nominal heat output range in heating mode
Pnc	Nominal heat output range in heating mode (condensing technology)
	Hot water generation
Qnw	Nominal heating load range in hot water handling mode
Pnw	Nominal heat output range in hot water handling mode
D	Specific flow rate
PMW	Maximum water pressure in hot water handling mode
	Barcode with serial number
GC No.	Gas council number



Note

Make absolutely sure that the product is compatible with the gas group at the installation site.

5.4 Serial number

The serial number can be found on a plastic label at the bottom of the front casing and on the identification plate.

5.5 Product design

5.5.1 Functional elements

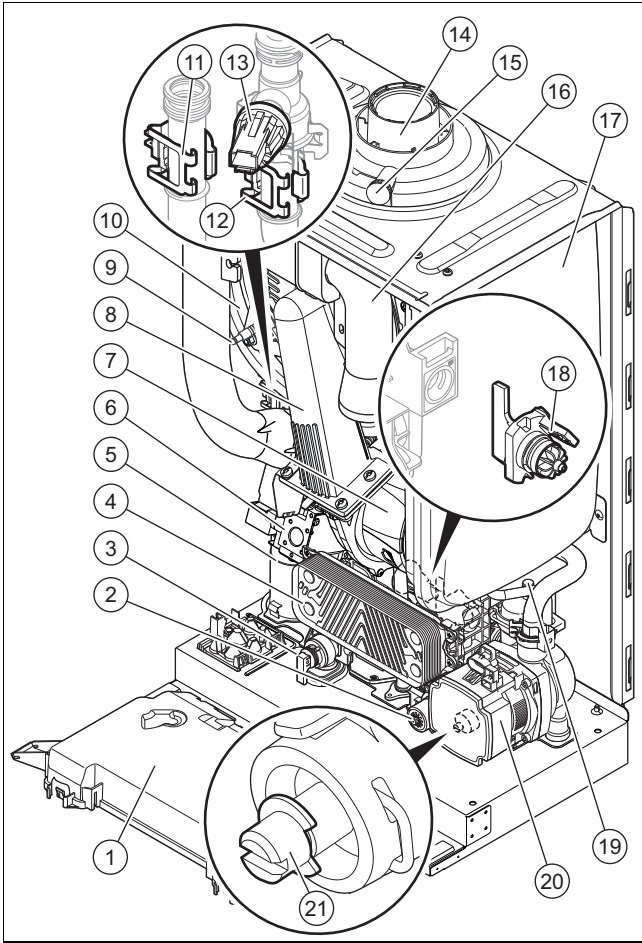

1	Electronics box	12	Temperature sensor in the heating return
2	Prioritising diverter valve	13	Water pressure sensor
3	Expansion relief valve	14	Connection for the air/flue pipe
4	Plate heat exchanger	15	Flue gas test point
5	Condensate siphon	16	Air intake pipe
6	Gas valve assembly	17	Expansion vessel
7	Fan	18	Impeller sensor (domestic hot water)
8	Compact thermal module	19	Automatic air vent
9	Ionisation and ignition electrode	20	Heating pump
10	Primary heat exchanger	21	Bypass
11	Temperature sensor in the heating flow		

5.6 Safety Devices

5.6.1 Electrical Supply Failure

The boiler will not work without an electrical supply. Normal operation of the boiler should resume when the electrical supply is restored.

Reset any external controls, to resume normal operation of the central heating.

If the boiler does not resume normal operation press the reset button. If the boiler does not resume normal operation after this call your Installation/ Servicing company or Vaillant service.

5.6.2 Overheating Safety

The boiler software is designed to recognise the potential for an overheat lockout and will shutdown before this happens. To restart the boiler, press the reset button on the boiler interface.

If the boiler fails to resume normal operation and all external controls are calling for heat, then call your Installation/ Servicing company or Vaillant service.

5.6.3 Frost protection

The appliance has a built in frost protection device that protects the boiler from freezing. With the gas and electric supplies ON and irrespective of any room thermostat setting, the frost protection device will operate the pump when the temperature of the boiler water falls below 12 °C.

A timer is used so that the temperature can be checked periodically. After 10 minutes the pump will be stopped if the temperature is higher than 10 °C or has already reached 35 °C. The burner will activate if the boiler temperature does not reach 10 °C after 30 minutes or at any time if the temperature drops to 5 °C.

The burner will switch off when the temperature reaches 35 °C.

5.6.4 Condensate Drain Blockage

As a safety feature the boiler will stop working if the condensate drain becomes blocked. During freezing conditions this may be due to the forming of ice in the condensate drain external to the house. Release an ice blockage by the use of warm cloths on the pipe. After pressing reset the boiler should restart.

6 Set-up

6.1 Checking the scope of delivery

- ▶ Check that the scope of delivery is complete and intact.

6.1.1 Scope of delivery

Number	Designation
1	Heat generator
1	Bag with accessories: <ul style="list-style-type: none"> - Unit mounting bracket - Bag with seals - Bag with bolts and wall plugs - Mounting template - Flexible condensate discharge pipe - Bag containing the hydraulic connections
1	Enclosed documentation

6.2 Dimensions

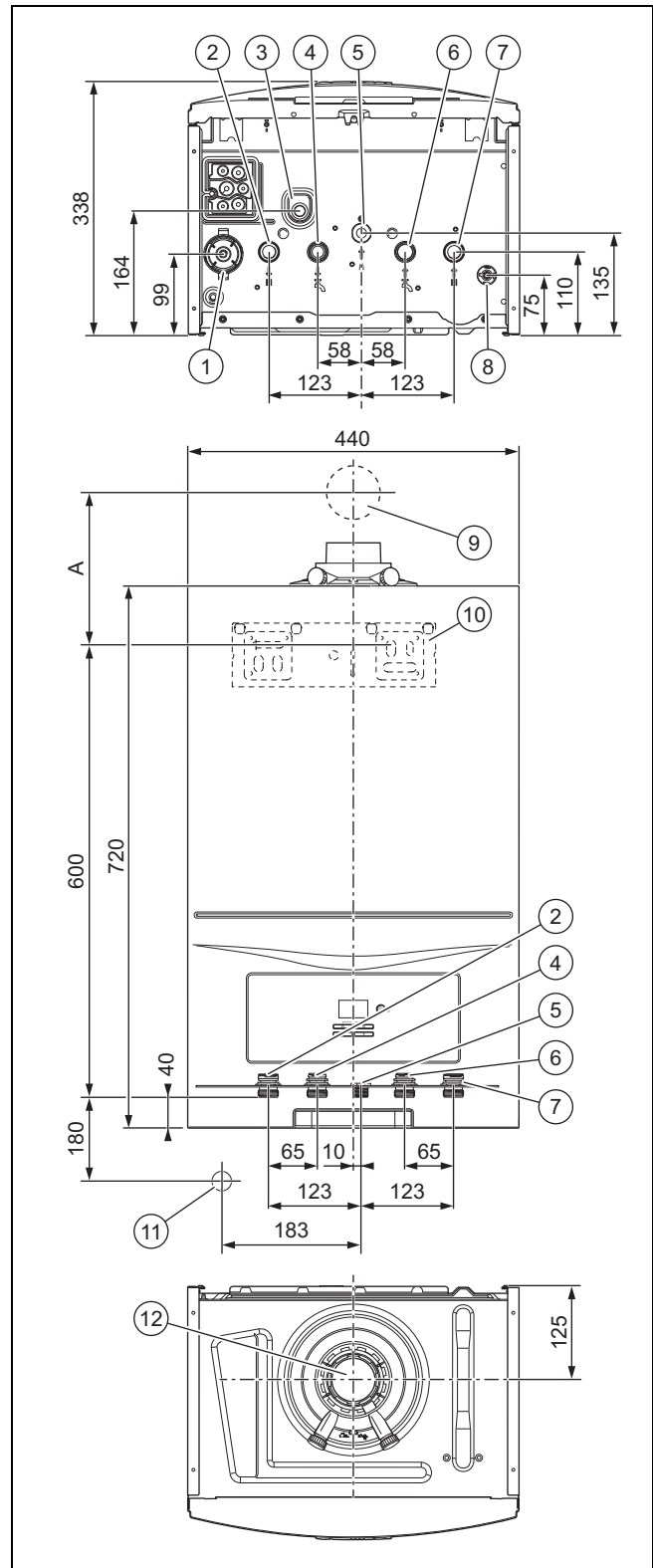

- | | | | |
|---|--|-----|--|
| 1 | Condensate siphon connection (condensate discharge connection, 21.5 mm diameter) | 6 | Cold water connection, G3/4 |
| 2 | Heating flow connection, G3/4 | 7 | Heating return connection, G3/4 |
| 3 | Heating expansion relief valve drain pipework connection, 15 mm diameter | 8 | Draining cock |
| 4 | Domestic hot water connection, G3/4 | 9 | Air/flue pipe wall duct |
| 5 | Gas connection, G1/2 | A = | see mounting template (60/100 mm diameter air/flue pipe) |
| | | A = | 235 mm (80/125 mm diameter air/flue pipe) |

- 10 Unit mounting bracket 12 Air/flue pipe connection
- 11 R1 tundish/condensate siphon connection

Consult the installation template that is supplied to find the dimension A.

6.3 Installation site

This boiler is not suitable for outdoor installation. This boiler may be installed in any room. However if the boiler is being installed in a room containing a bath or shower it must only be installed in zones 2 or 3. In GB this is the current I.E.E. WIRING REGULATIONS and BUILDING REGULATIONS. In IE reference should be made to the current edition of I.S.813 "Domestic Gas Installations" and the current ETCI rules.

If the boiler is to be installed in a timber frame building it should be fitted in accordance with the current version of the Institute of Gas Engineers document IGE/UP/7. If in doubt seek advice from local gas undertaking or the manufacturer.

6.4 Minimum clearances

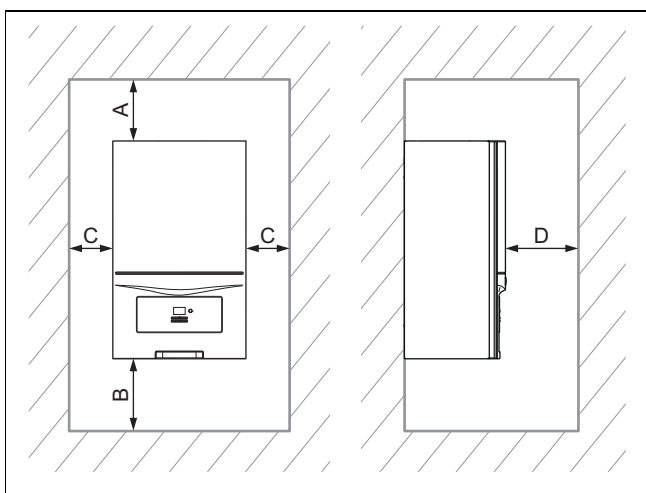

	Minimum clearance
A	165 mm: Air/flue pipe, 60/100 mm diameter 275 mm: Air/flue pipe, 80/125 mm diameter
B	180 mm; optimum approx. 250 mm
C	5 mm; optimum approx. 50 mm
D	500 mm clearance in front of the heat generator to enable easy access for maintenance work (the same as a door opening). Can be reduced to 5 mm if fitted behind removable door / panel.

The boiler and flue are suitable for installation onto and through combustible materials provided that:

1. Minimum 5 mm clearance is maintained around the circumference of the flue (air intake).
2. The combustible surface and fixings are suitable for supporting the load.
3. The minimum clearances from the boiler case are maintained.

6.5 Compartment Ventilation

The boilers are very high efficiency appliances.

As a consequence the heat loss from the appliance casing during operation is very low.

Compartment ventilation is not required as the products are only certified, and can only be fitted with a concentric flue system.

6.6 Air/flue pipe

6.6.1 Regulation

Different flue outlet configurations can be carried out.

- Consult the installation manual for air/flue gas systems for more information about the other possibilities and associated accessories.

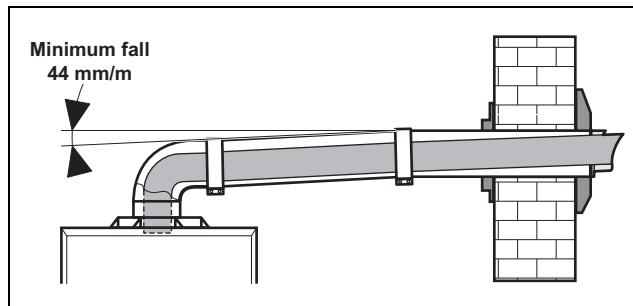

- Standard flue terminal kits have an in-built fall back to the boiler to drain the condensate. These can be fitted level between the appliance and the termination position. All other extended flues must have a fall of at least 44 mm/m.

The maximum length of the flue outlet is defined according to its type (for example C13).

- Whatever the kind of flue system chosen, observe the minimum distances to position the flue terminals.
- To install the flue, refer to the separate flue instruction supplied with your appliance.
- Explain these requirements to the user of the appliance.

In GB the minimum acceptable siting dimensions for the terminal from obstructions, other terminals and ventilation openings are shown in diagram overleaf.

In IE the minimum distances for flue terminal positioning must be those detailed in I.S. 813 "Domestic Gas Installations".

The terminal must be exposed to the external air, allowing free passage of air across it at all times.

Being a condensing boiler some plumbing may occur from the flue outlet. This should be taken into consideration when selecting the position for the terminal.

6.6.2 Position of the air/flue terminal

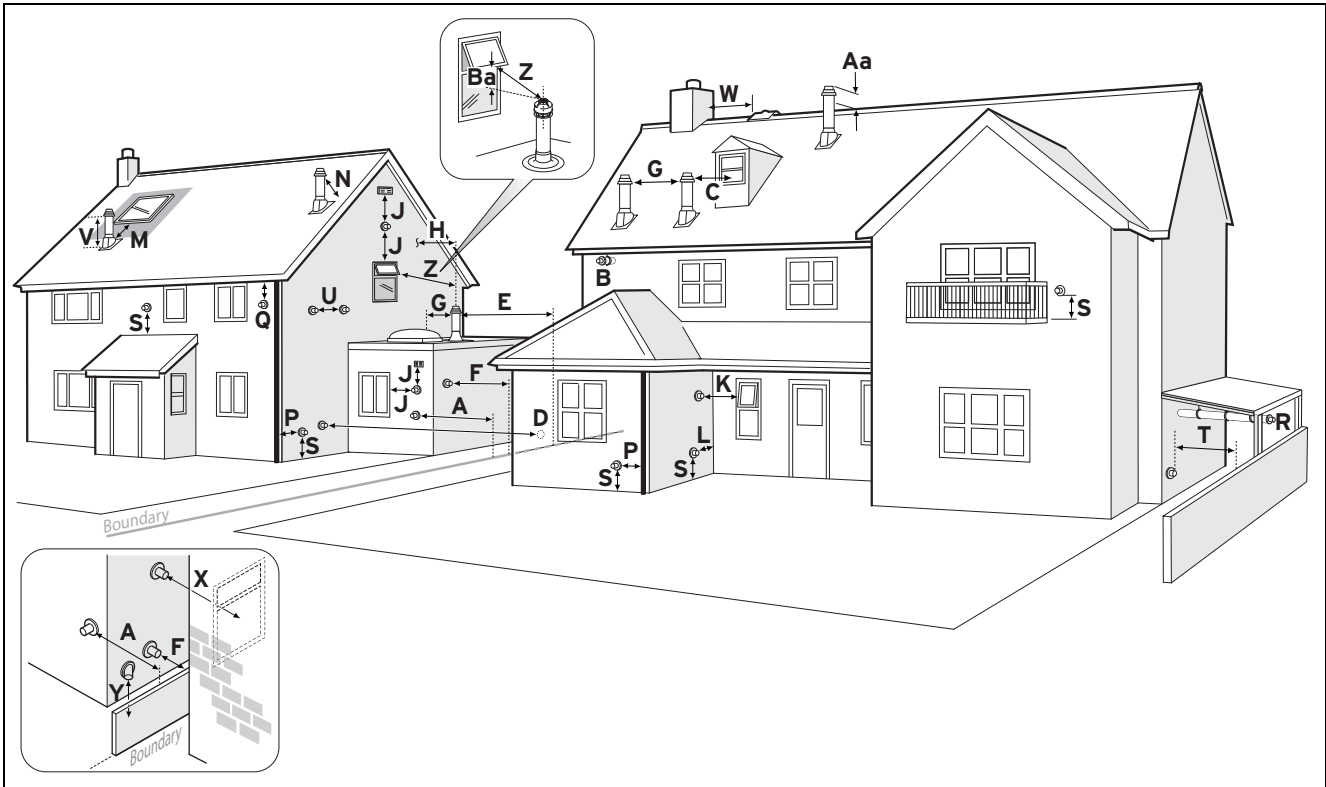

6.6.2.1 Positioning the terminal of a fan-supported flue system

	Installation site	Dimensions
A	Adjacent to a boundary.	300 mm
B ¹⁾	The dimension below eaves, balconies and car ports can be reduced to this value, as long as the flue terminal is extended to clear any overhang. External flue joints must be sealed with a suitable silicon sealant.	25 mm
C	Between a vertical flue terminal and a window or dormer window on a roof.	1,500 mm
D	Between terminals facing each other.	1,200 mm
E	Vertical flue clearance, adjacent to a boundary line.	300 mm
F ²⁾	Distance to a boundary line, unless it will cause a nuisance. BS 5440:Part 1 recommends that care is taken when siting terminal in relation to boundary lines.	600 mm
G	Minimum clearance from a skylight to a vertical flue or to another vertical flue.	Min. 300 mm
H	Vertical flue clearance, to noncombustible building material. Vertical flue clearance to combustible building material.	500 mm 1,500 mm
J	Above, below and either side of an opening door, air vent or opening window.	300 mm
K	Diagonally to an opening door, air vent or opening window.	600 mm
L ²⁾	To an internal or external corner.	200 mm
M	Below a Velux window. Above or to either side of the Velux window.	2,000 mm 600 mm
N	From a pitched roof. In regions with heavy snowfall.	400 mm 500 mm
P	From vertical drain pipes and soil pipes.	25 mm
Q	Below eaves. Below gutters, pipe and drains.	200 mm 75 mm
	<p>1) There should be no ventilation/opening in the eaves within 300 mm distance of the terminal.</p> <p>2) These dimensions comply with the building regulations, but they may need to be increased to avoid wall staining and nuisance from pluming depending on site conditions.</p> <ul style="list-style-type: none"> - Terminals must be positioned so to avoid combustion products entering the building. - Support the flue at approximately one metre intervals and at a change of direction, use suitable brackets and fixings. - Installations in car ports are not recommended. - The flue cannot be lower than 1 metre from the top of a lightwell due to the build up of combustion products. - Dimensions from a flue terminal to a fanned air inlet to be determined by the ventilation equipment. 	

	Installation site	Dimensions
R	The dimension below eaves, balconies and car ports can be reduced to this value, as long as the flue terminal is extended to clear any overhang. External flue joints must be sealed with suitable silicon sealant.	25 mm
S	Above adjacent ground or balcony.	300 mm
T ²⁾	Distance to a surface facing a terminal, unless it will cause a nuisance. BS 5440: Part 1 recommends that care is taken when siting terminals in relation to surfaces facing a terminal.	600 mm
U	Clearance alongside another terminal.	300 mm
V	Above roof level.	300 mm
W	Minimum to vertical structure on roof, roof vent.	Min. 300 mm
X	Minimum to opening in adjacent building.	Min. 2000 mm
Y	Minimum at an angle to a boundary which is not less than 300 mm to the terminal	Min. 600 mm
Z	Minimum measured to the nearest corner of the OPEN window	Min. 600 mm
Aa	No more than this value above ridge.	Max. 300 mm
Ba	Not less than this value below the opening window	Min. 300 mm
	1) There should be no ventilation/opening in the eaves within 300 mm distance of the terminal. 2) These dimensions comply with the building regulations, but they may need to be increased to avoid wall staining and nuisance from pluming depending on site conditions. <ul style="list-style-type: none"> - Terminals must be positioned so to avoid combustion products entering the building. - Support the flue at approximately one metre intervals and at a change of direction, use suitable brackets and fixings. - Installations in car ports are not recommended. - The flue cannot be lower than 1 metre from the top of a lightwell due to the build up of combustion products. - Dimensions from a flue terminal to a fanned air inlet to be determined by the ventilation equipment. 	

6.6.2.2 Horizontal terminal positioning

BS 5440-1 recommends that fanned flue chimney terminals should be positioned as follows:

- a) at least 2 m from an opening in the building directly opposite, and
- b) so that the products of combustion are not directed to discharge directly across a boundary if the products are likely to cause a nuisance to a neighbour or discharge over a walkway or patio.

For IE see current issue of IS 813.

For boilers covered within this manual.

Dimensions B and R:

These clearances may be reduced to 25 mm without affecting the performance of the boiler. In order to ensure that the condensate plume does not affect adjacent surfaces the terminal should be extended as shown below.

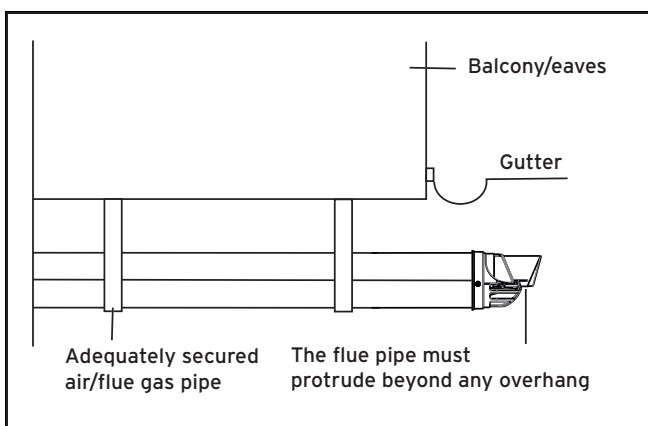

You can use a plume management kit to enable the termination point to be positioned and directed away from the building fabric.

6.6.3 Flue Configuration Description

6.6.3.1 Horizontal Concentric Flue \varnothing 60/100 mm or \varnothing 80/125 mm (C13 type installation)

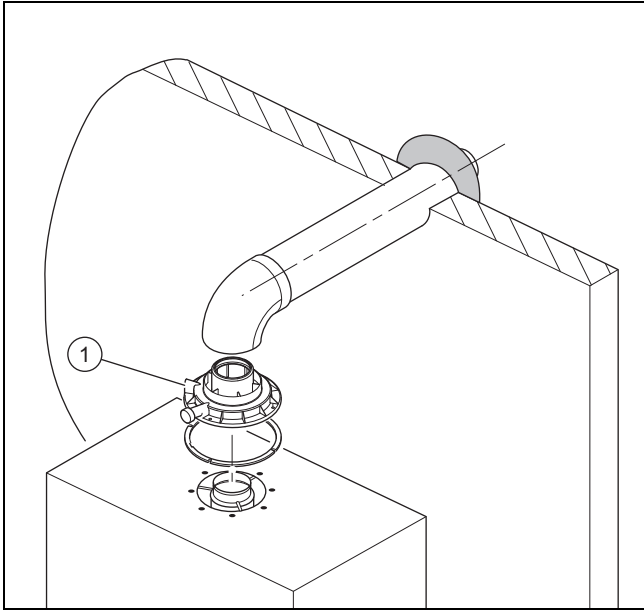

1 Gasket (fitted)



Note

If the terminal is at less than 1.80 m from the ground, you must install a terminal protection kit.

Consult the separate installation manual for air/flue gas systems supplied with your appliance for all possibilities and associated accessories and how to install the flue system.

6.6.3.2 Terminal protection

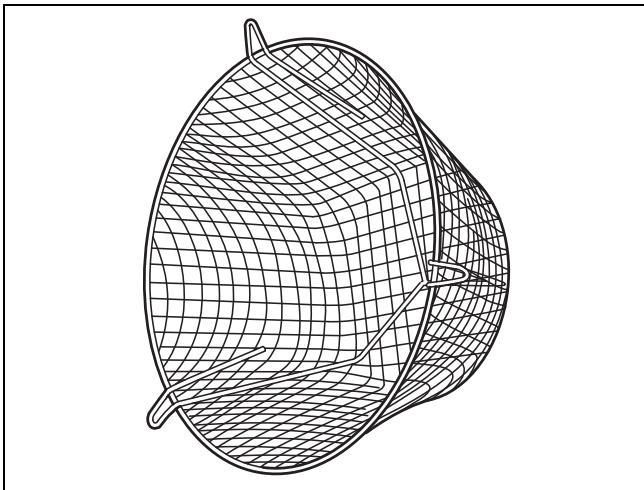

A terminal guard is required if persons could come into contact with the terminal or the terminal could be subject to damage.

If a terminal guard is required, it must be positioned to provide minimum of 50 mm clearance from any part of the terminal and be central over the terminal.

The guard should be similar to that shown in the figure.

6.6.3.3 Vertical Concentric Flue \varnothing 60/100 mm or \varnothing 80/125 mm (C33 type installation)

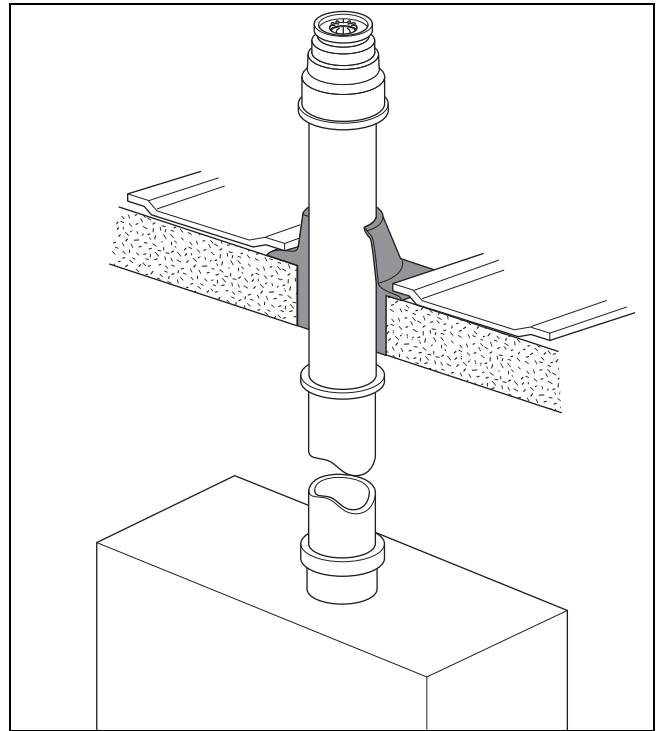

Consult the separate installation manual for air/flue gas systems supplied with your appliance for all possibilities and associated accessories and how to install the flue system.

6.6.3.4 Multiple boiler chimney Flue \varnothing 60/100 mm (C43 type installation)

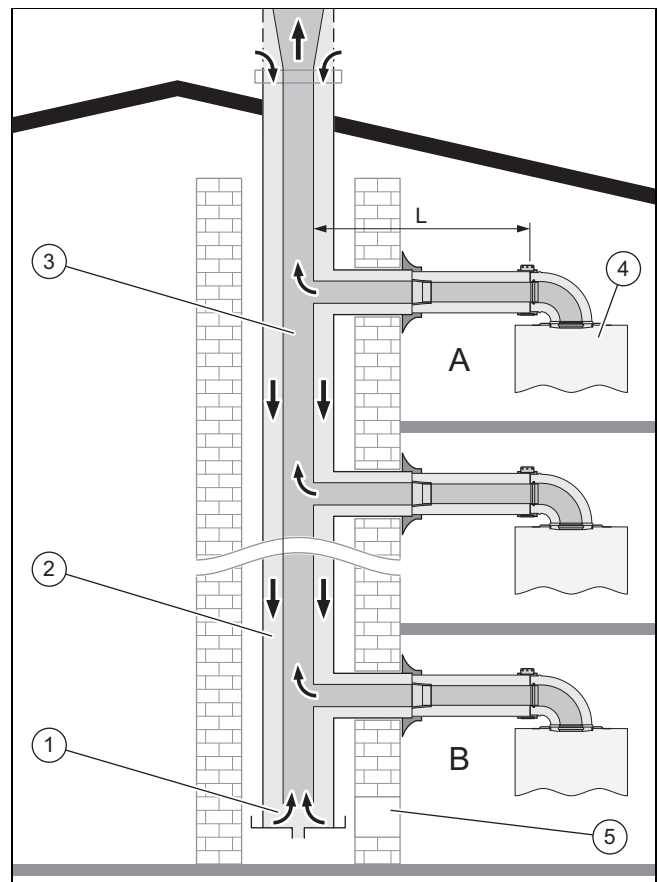

1 Pressure balancing system

2 Air-inlet pipe

3 Collector pipe

4	Boiler	A	Final storey
5	Inspection hatch	B	Ground floor



Note

The flue connecting from the appliance to the flue system must be supplied from the manufacturer of the boiler.

C43 flue systems must not be a 'pressurised system' but act under natural draught principles.

C43 type flue systems must have their own condensate drain fitted and not allow condensate to mix into other appliances.

The flue length must be calculated and installed according to the relevant standards EN 13384-1 and 2 (C43 flue systems only) with reference to the manufacturer's instructions supplied. The appliance maximum flue length must be taken into account when calculating the overall design of the flue system.

Consult the separate installation manual for air/flue gas systems supplied with your appliance for all possibilities and associated accessories and how to install the flue system.

6.7 Using the installation template

- Use the installation template to ascertain the locations at which you need to drill holes and make breakthroughs.

6.8 Wall-mounting the product

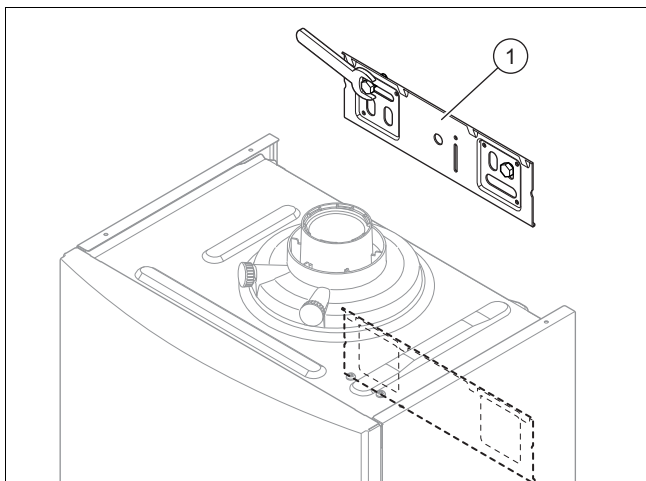

1. Check the load-bearing capacity of the wall.
2. Note the total weight of the product.
3. Only use fixing material that is permitted for the wall.
4. If required, ensure that mounting apparatus on-site has sufficient load-bearing capacity.
5. Wall-mount the product as described.

6.9 Removing/installing the front casing

6.9.1 Removing the front casing

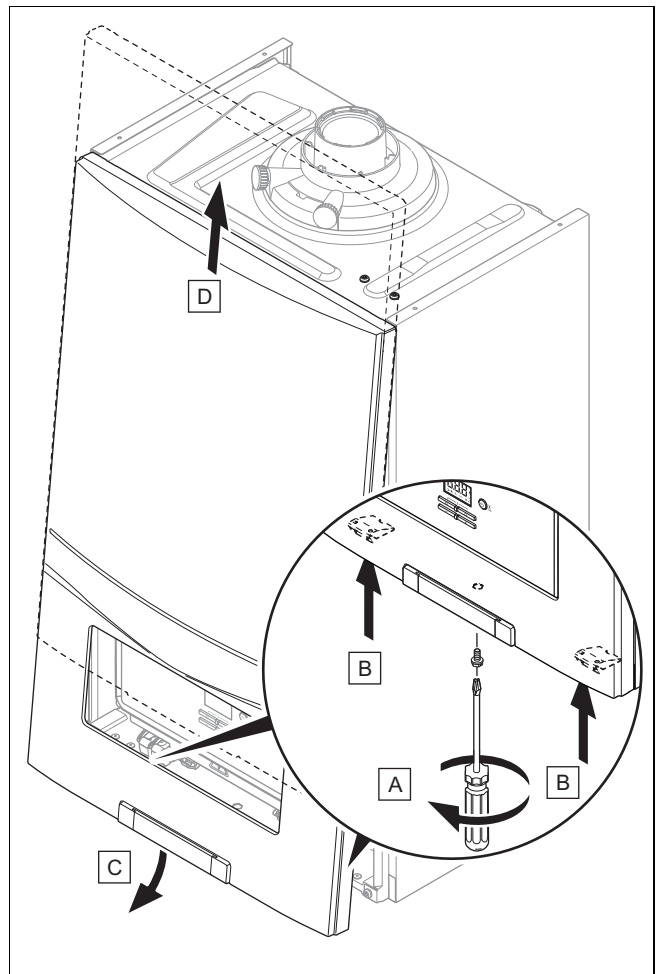

- Remove the front casing as shown in the illustration.

6.9.2 Installing the front casing

- Refit the components in the reverse order.

6.10 Removing/installing the side section

6.10.1 Removing the side section

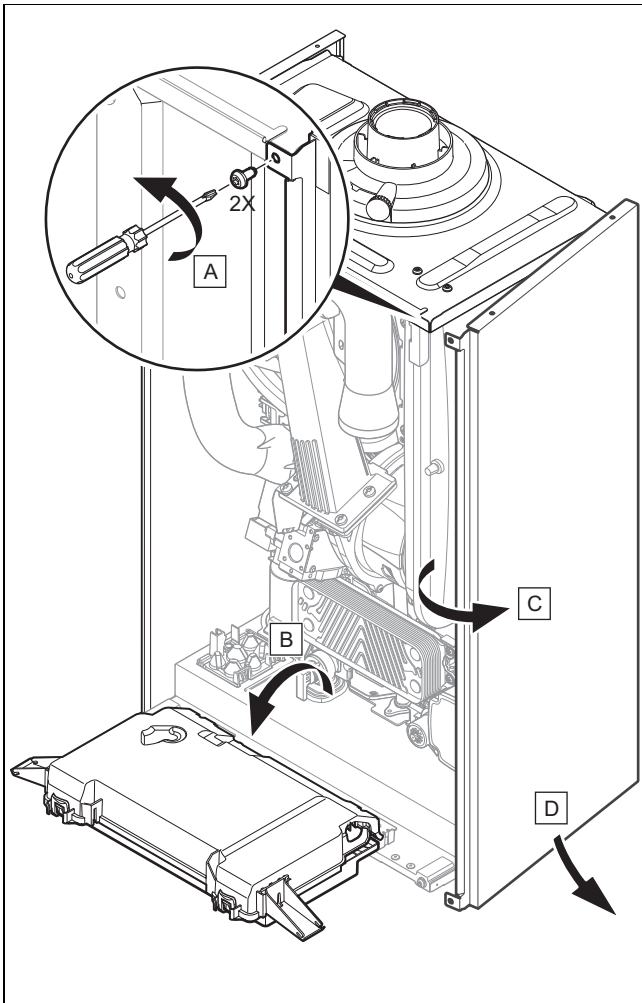

Caution.

Risk of material damage caused by mechanical deformation.

Removing both side sections may cause mechanical distortion in the product, which may cause damage to the piping, for example, and potentially result in leaks.

- ▶ Always only remove one side section – never both side sections at the same time.

- ▶ Remove the side section as shown in the illustration.

6.10.2 Installing the side section

- ▶ Refit the components in the reverse order.

7 Installation

7.1 Preparing for installation

- ▶ Make sure that the existing gas meter is capable of passing the rate of gas supply required.
- ▶ Consider the maximum heat output given in DHW mode.
- ▶ Install a system separator (to be provided on-site) directly on the cold water connection for the combi boiler.
- ▶ Install the following components:
 - Draining cocks at the lowest points in the heating installation (→ current version of "BS 2879")
 - A stopcock on the cold water connection
 - A stopcock in the gas pipe
- ▶ Check that the volumetric capacity of the expansion vessel is sufficient for the system volume.
 - ▽ If the volume of the expansion vessel is insufficient for the installation.
 - ▶ Install an additional expansion vessel in the heating return, as close to the product as possible.
 - ▶ Install a non-return flap at the product's outlet (heating flow).
- ▶ Install the connection pipes such that they are free from mechanical stress.
- ▶ If you use non-diffusion-tight plastic pipes in the heating installation, ensure that no air gets into the heat generator circuit.
- ▶ Only solder connectors if the connectors are not yet screwed to the service valves.
- ▶ Only bend connection pipes if they have not yet been connected to the product.
- ▶ Flush the heating installation thoroughly before installing the product.
- ▶ Check the leak-tightness of the gas valve assembly using a pressure of ≤ 11 kPa (110 mbar).

7.2 Information on the gas group

In the as-supplied condition, the product is preset for operation with the gas group indicated on the data plate.

7.3 Purging the liquid gas tank

If the liquid gas tank is not purged properly, this may result in ignition problems.

- ▶ Ensure that the liquid gas tank has been purged properly before installing the product.
- ▶ If required, contact the filler or the liquid gas supplier.

7.4 Using the correct gas type

Using the incorrect gas type may cause fault shutdowns in the product. Ignition and combustion noise may occur in the product.

- ▶ Only use the gas type listed on the data plate.

7.5 Descaling the water

Scale deposition increases as the water temperature increases.

- ▶ Descale the water as required.

7.6 Gas family check

Make sure that the product is set up correctly by checking the gas type. This ensures optimum combustion quality.

- ▶ Check the gas type as part of routine product maintenance work when replacing components or carrying out work on the gas route.

7.7 Gas and water connections

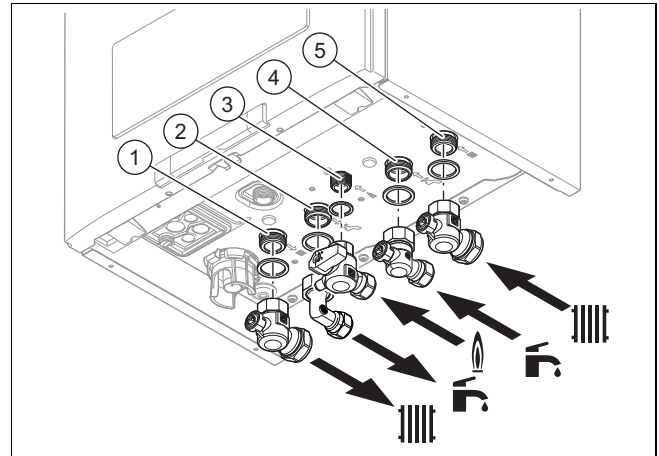

- | | | | |
|---|-------------------------------|---|---|
| 1 | Heating flow connection, G3/4 | 4 | Connection for the cold water supply line, G3/4 |
| 2 | Hot water connection, G3/4 | 5 | Heating return connection, G3/4 |
| 3 | Gas connection, G1/2 | | |

1. Connect the water and gas connections in accordance with the applicable standards.
2. Purge the gas pipe before start-up.
3. Check whether the connections are leak-tight.
4. Check the entire gas pipe properly for leak-tightness.

7.8 Connecting the condensate discharge pipe

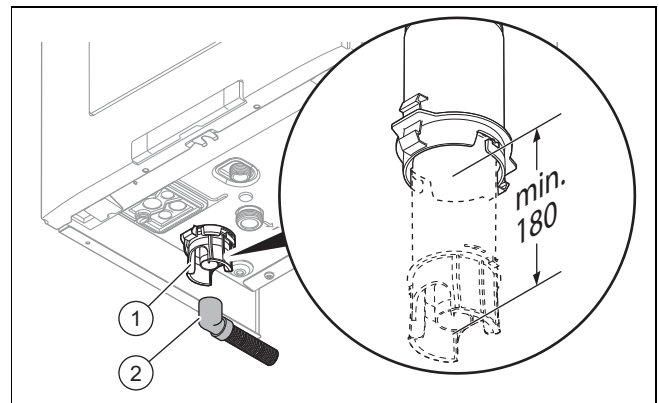

- ▶ Follow the instructions listed here and observe directives and local regulations on condensed water discharge.
- ▶ Use PVC or another material that is suitable for draining the non-neutralised condensed water.
- ▶ If you cannot guarantee that the materials from which the condensate discharge pipe is made are suitable, install a system to neutralise the condensate.

**Note**

The condensate drain pipework must have a continuous fall (45 mm per metre) and should whenever possible terminate at a suitable drain point within the heated envelope of the building that will remain frost free under long periods of low external temperatures.

**Note**

Ensure that the connection between the condensate discharge pipe and the drain hose is not air-tight.

- ▶ Connect the condensate siphon (1). Use the supplied condensate discharge hose (2) to do this.
- ▶ Connect a condensate discharge pipe (21.5 mm, not included in the scope of delivery) to the condensate discharge hose (2).
- ▶ During installation remove all burrs from inside of cut pipe work and avoid excessive adhesive which may trap small pockets of water close to the pipe wall which can freeze and build into a larger ice plug.
- ▶ As with other pipe work insulate the condensate discharge pipe to minimise any risk of freezing and beware when crossing cavities that the fall is maintained and the pipe sleeved.

You can find further information in the "BS 6798" specification for installing and maintaining gas-fired boilers with a nominal heat input of less than 70 kW.

7.8.1 Condensate discharge systems

It is not necessary to provide extra traps in the discharge pipe as there is already a trap inside the boiler. Fitting an extra trap may cause the boiler siphon to work incorrectly. Refer to BS5546 or BS6798 for further advice on disposal of boiler condensate.

7.8.1.1 Direct Connection to internal soil and vent stack

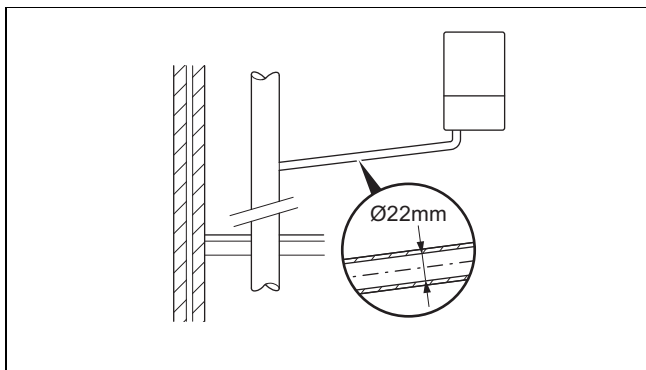

Preferred option

7.8.1.2 Direct connection to external soil and vent stack

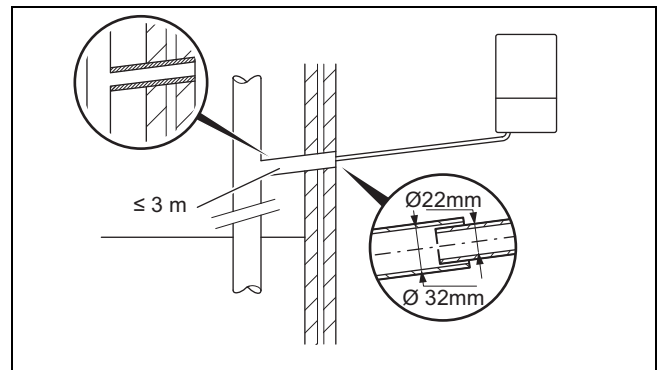

7.8.1.3 External termination to gulley or hopper

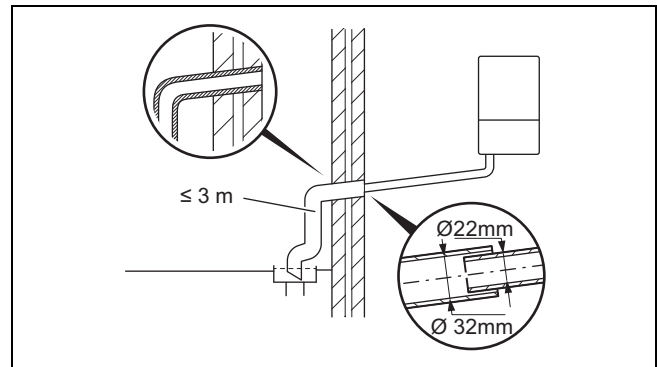

Best practice

7.8.1.4 Internal termination into combined sink waste

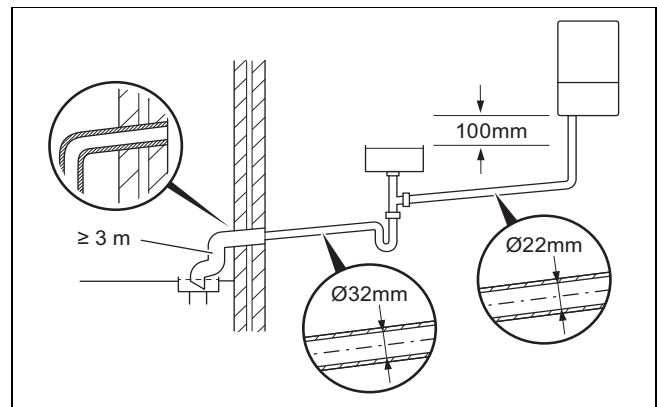

Preferred option for external termination

7.8.1.5 External termination into soakaway

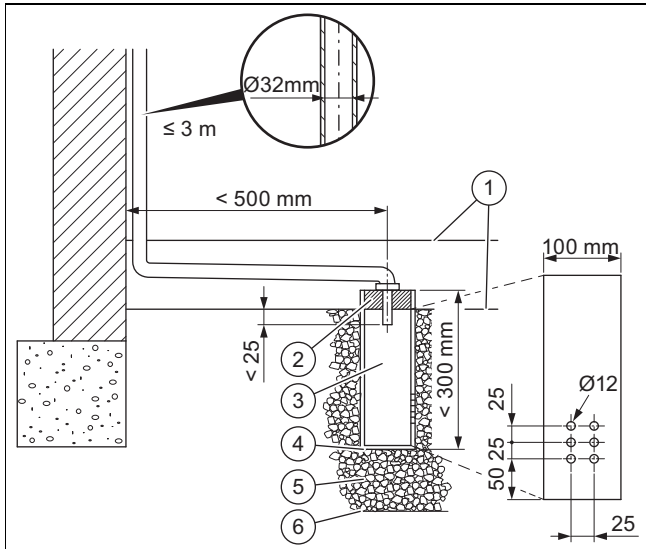

- | | | | |
|---|----------------------------------|---|------------------------------|
| 1 | Ground (either/or) | 4 | Bottom of sealed tube |
| 2 | Seal | 5 | Limestone chippings |
| 3 | Plastic tube,
100 mm diameter | 6 | Hole depth 400 mm
minimum |

Least preferred option, must not terminate in rain water drain

7.8.1.6 Internal termination downstream of sink waste

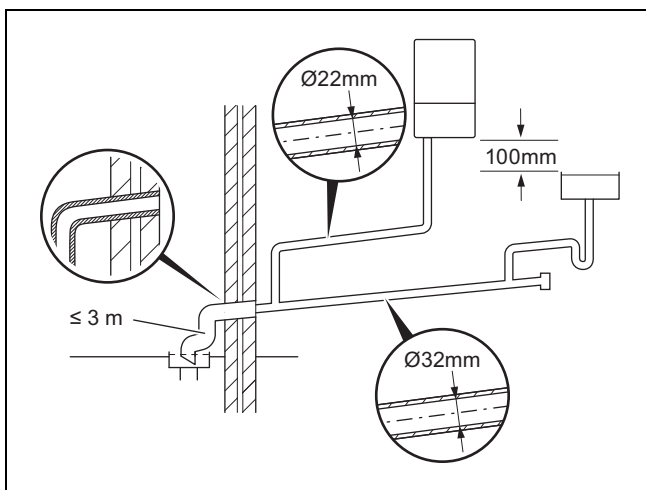

Open end of pipe direct into gully below ground level but above water level

Susceptible to siphonage, must terminate in a gully

7.8.1.7 External termination into rain water down pipe

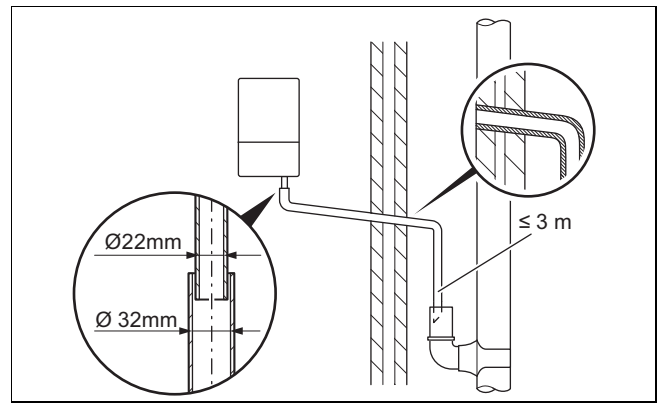

NB only combined foul/rainwater drain

7.8.1.8 Additional methods of introducing air breaks

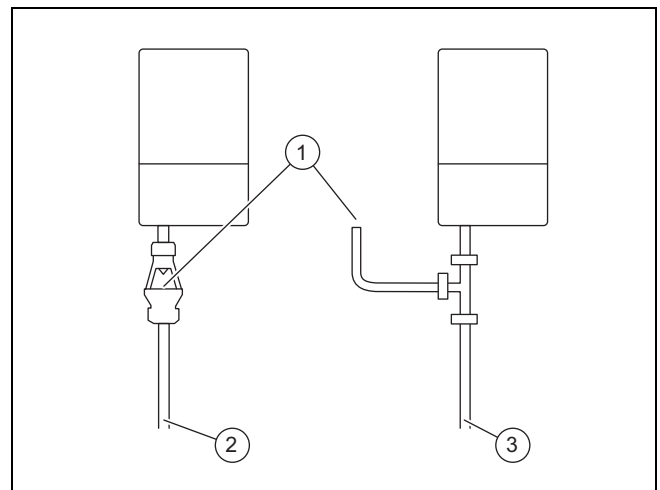

- | | | | |
|---|-----------------|---|--------------|
| 1 | Air break | 3 | Using a pipe |
| 2 | Using a tundish | | |

7.8.1.9 Connection of condensate pump

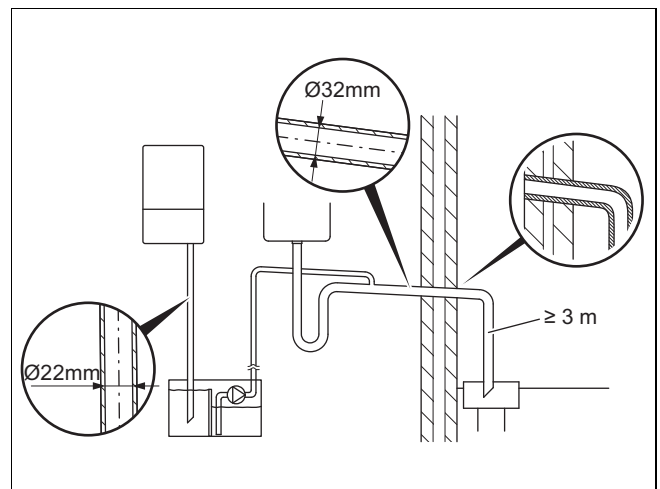

Preferred option for external connection

7.9 Installing the discharge pipe on the expansion relief valve

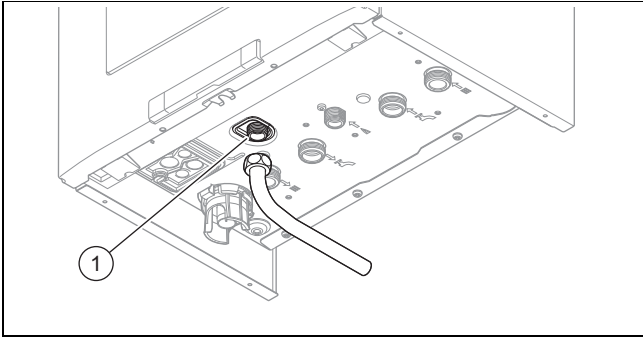

1. Ensure that the pipeline is visible.
2. Connect the expansion relief valve (1).
3. The pipe must have a continuous fall and be routed to a position so that any discharge of water, possibly boiling, or steam cannot create any danger to persons, damage to property or external electrical components and wiring.
 - ◁ The components must be set up in such a way that you can see the water flowing out.

7.10 Flue installation

7.10.1 Installing and connecting the air/flue pipe

1. You can find out which air/flue pipes may be used by consulting the enclosed set-up instructions for the air/flue system.

Condition: Installation in damp rooms

- ▶ You must connect the product to a room-sealed air/flue system. The combustion air must not be taken from the installation site.

2. Install the air/flue pipe as described in the set-up instructions.

7.10.2 Replacing the connector for the air/flue pipe as required

1. Replace the connector for the air/flue pipe as required. The product-specific standard equipment is listed under Technical data.
2. Remove the connection piece for the air/flue pipe – this is installed at the factory. (→ Page 23)
3. If required, install the connection piece for the air/flue pipe, 80/125 mm diameter. (→ Page 23)

7.10.2.1 Removing the connection piece for the air/flue pipe

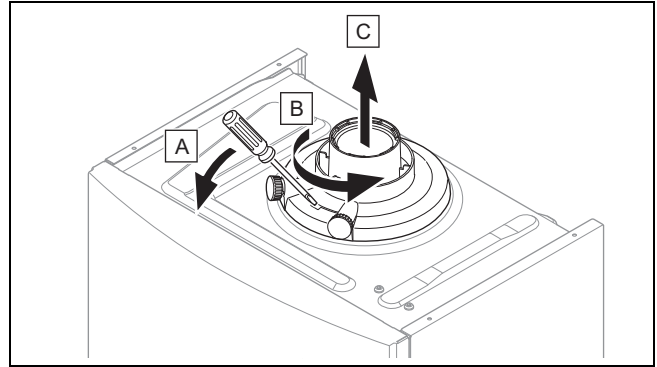

1. Insert a screwdriver into the gap between the measuring points.
2. Press the screwdriver carefully down.
3. Turn the connection piece anticlockwise as far as it will go and then remove it by pulling it upwards.

7.10.2.2 Installing the connection piece for the air/flue pipe, 80/125 mm diameter

1. Remove the connection piece for the air/flue pipe – this is installed at the factory. (→ Page 23)
2. Insert the alternative connection piece. Pay attention to the lugs.
3. Turn the connection piece clockwise until it clicks into position.

7.11 Electrical installation

The electrical installation must only be carried out by a qualified electrician.



Danger!

Risk of death from electric shock!

Power supply terminals L and N remain live even if the on/off button is switched off:

- ▶ Disconnect the product from the power supply by switching off all power supplies at all poles (electrical partition with a contact gap of at least 3 mm, e.g. fuse or circuit breaker).
- ▶ Secure against being switched back on again.
- ▶ Wait for at least 3 minutes until the capacitors have discharged.
- ▶ Check that there is no voltage.

7.11.1 Opening the electronics box

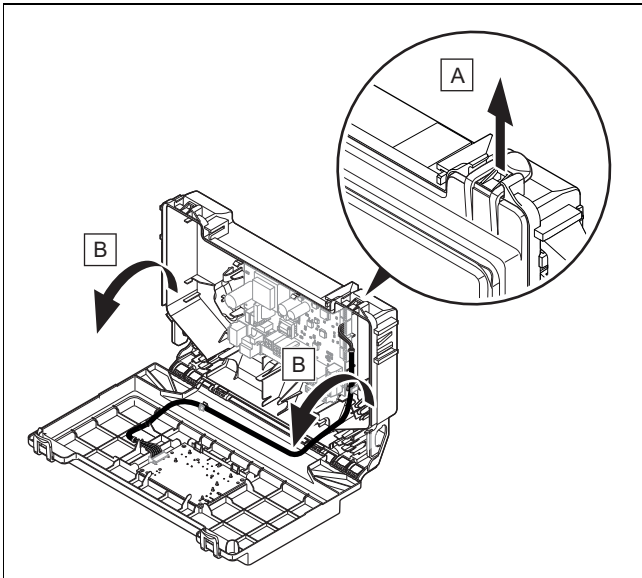

7.11.2 Cable route

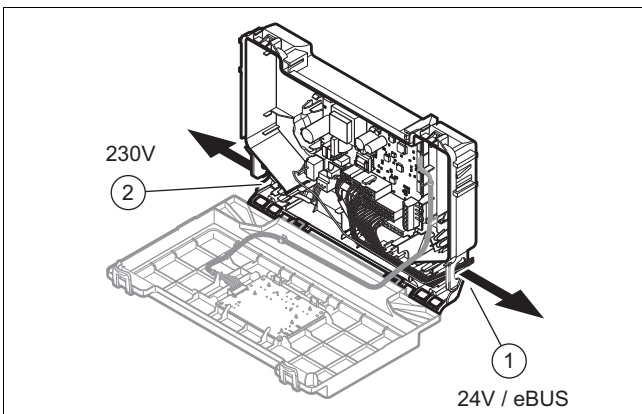

1 24-V eBUS cable route

2 230 V cable route

7.11.3 General information about connecting cables



Caution.

Risk of material damage caused by incorrect installation.

Mains voltage at incorrect terminals and plug terminals may destroy the electronics.

- ▶ Do not connect any mains voltage to the eBUS (+/-) and RT 24 V terminals.
- ▶ Only connect the connection cable to the terminals marked for the purpose.

1. Route the connection cables of the components to be connected through the grommet provided on the underside of the product on the left.
2. Ensure that the grommet is plugged in correctly and that the cables have been routed correctly.
3. Ensure that the grommets envelop the connection cables tightly and with no visible gaps.
4. Use strain reliefs.

5. If required, shorten the connection cables.

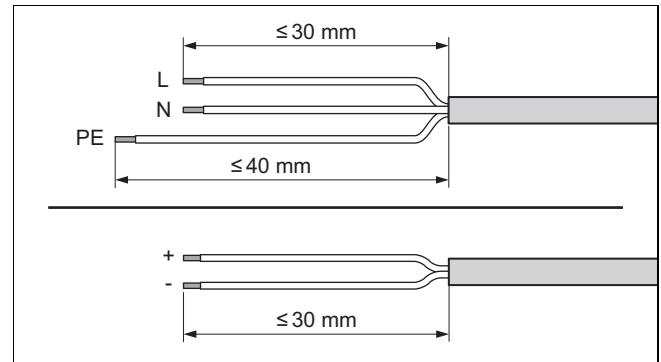

6. Strip the flexible cables as shown in the figure. In doing so, ensure that the insulation on the individual conductors is not damaged.
7. Only strip inner conductors just enough to establish stable connections.
8. To avoid short circuits resulting from loose individual wires, fit conductor end sleeves on the stripped ends of the conductors.
9. Screw the respective plug to the connection cable.
10. Check whether all conductors are inserted mechanically securely in the terminals of the plug. Remedy this if necessary.
11. Plug the plug into the associated PCB slot.
 - In doing so, observe the wiring diagram in the appendix.

7.11.4 Establishing the power supply

1. Observe all valid regulations.
 - The applicable regulations state that the connection must be established via an electrical partition with a contact gap of at least 3 mm at each pole.
 - Power supply cable: Flexible duct
2. Make sure that the rated voltage of the mains is 230 V.

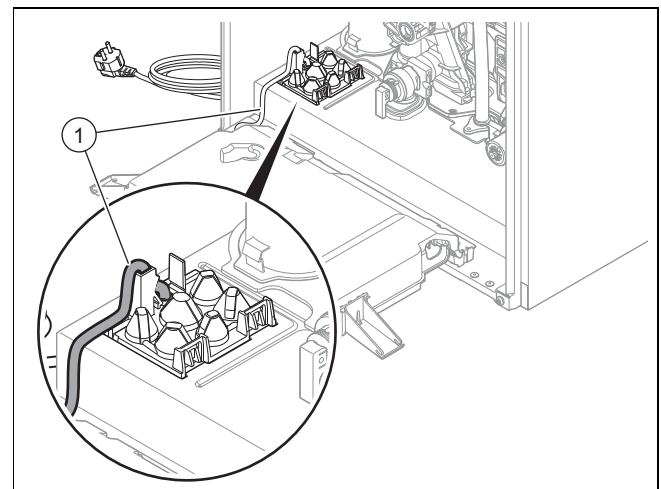

3. Route a three-core power supply cable that complies with the relevant standards through the grommet and into the product.
4. Do not interrupt the mains supply with a time switch or programmer.
5. Isolation should preferably be by a double pole switched fused spur box having a minimum contact separation of 3mm on each pole. The fused spur box should be readily accessible and preferably adjacent to the boiler. It should be identified as to its use.

6. Observe the routing of the power supply cable (1) in the grommet in order to guarantee that there is no strain.
7. Open the electronics box. (→ Page 24)

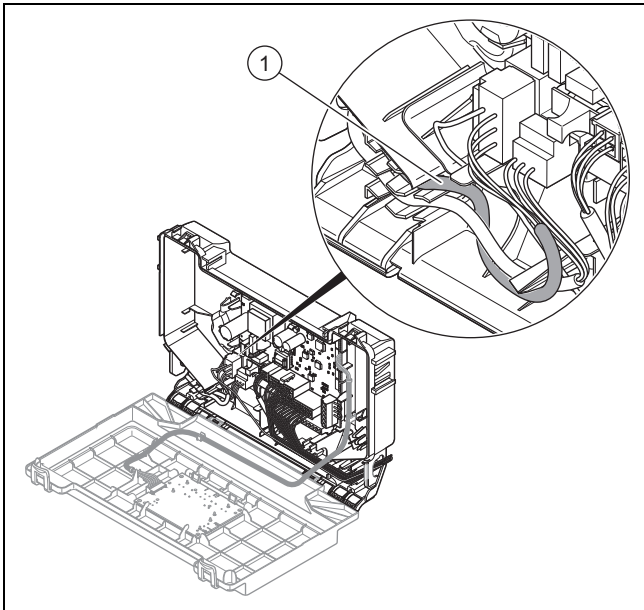

8. Observe the routing of the power supply cable (1) in the electronics box in order to guarantee that there is no strain.
9. Provide one common power supply for the boiler and for the corresponding control:
 - Power supply: Single-phase, 230 V, 50 Hz
 - Fuse: ≤ 3 A

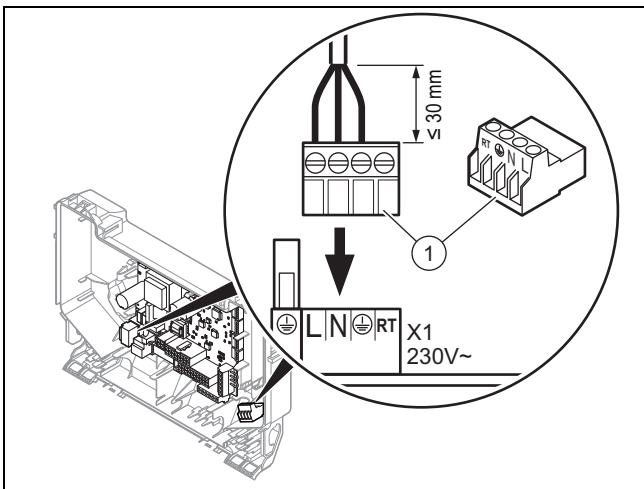

10. Connect the cables. (→ Page 24)
11. Screw the supplied plug (1) to a three-core power supply cable that complies with the relevant standards.
12. Plug the plug for the power supply cable into a suitable plug socket.
13. Make sure that access to the power supply is always available and is not covered or blocked.
14. Close the electronics box.

7.11.5 Connecting controls to the electronics

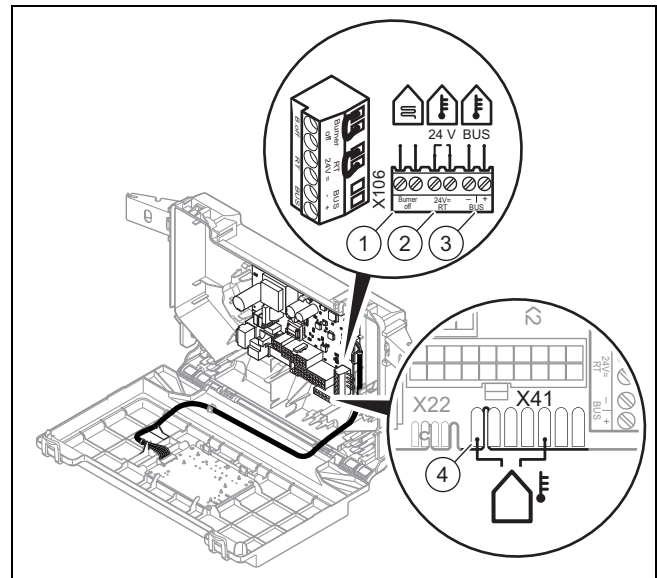

- | | | | |
|---|---|---|-------------------------------------|
| 1 | Limit thermostat for underfloor heating | 3 | eBUS control or radio receiver unit |
| 2 | 24 V control | 4 | Outdoor temperature sensor, wired |

1. Ensure that the product is voltage-free.
2. Connect the cables. (→ Page 24)
3. Connect the individual components depending on the installation type.

Condition: Connecting a limit thermostat for underfloor heating

- ▶ Remove the bridge and connect the limit thermostat to the Burner off connection.
- ▶ For multi-circuit controls (→ Page 27), change the parameter d.18 from Eco (intermittently operating pump) to Comfort (continuously operating pump).

Condition: If you are connecting a control (230 V).

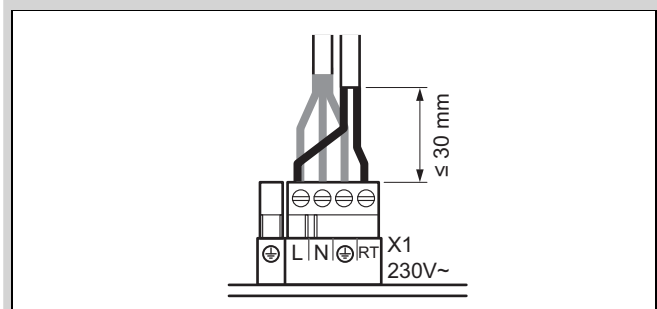

- ▶ Connect the control to the main plug.

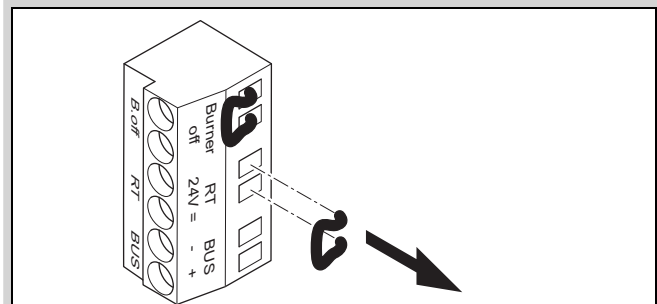

- ▶ Remove the bridge from the 24V=RT plug.

4. Close the electronics box.

7.11.6 Connecting additional components via VR 40 (2 in 7 multi-functional module)

1. Install the components in accordance with the respective instructions.

Condition: Components connected to relay 1

▶ Activate d.27. (→ Page 27)

Condition: Components connected to relay 2

▶ Activate d.28. (→ Page 27)

8 Operation

8.1 Operating concept

The operating concept and the display and setting facilities of the operator level are described in the operating instructions.

An overview of the display and setting options in the installer level can be found in the section "Overview of the installer level". (→ Page 27)

8.2 Installer level overview

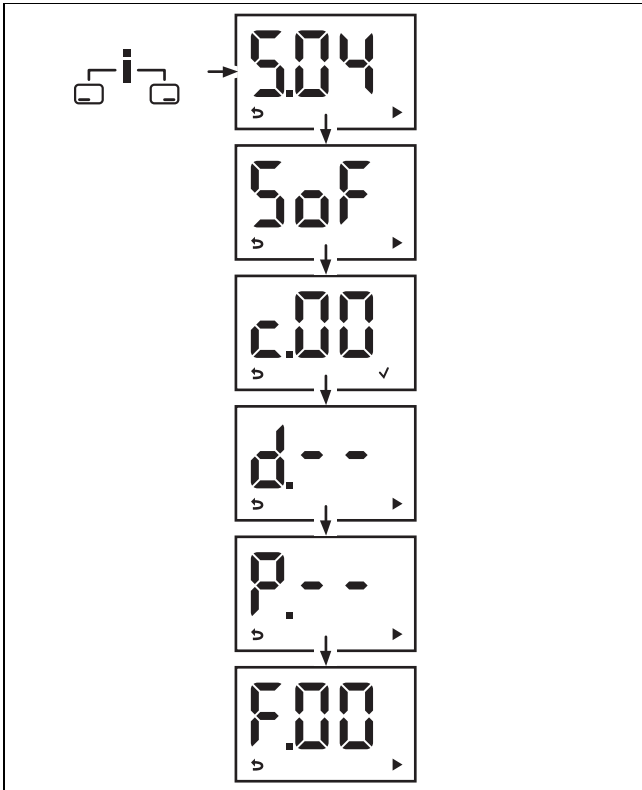

8.3 Calling up the installer level

1. Only call up the installer level if you are a competent person.
2. Press and ("i") at the same time.
 - ◁ S.xx (current unit status) appears in the display, followed by the heating flow temperature and the heating installation pressure.
3. Press to access the installer level.
 - ◁ SoF and the software version appear in the display.
4. Press .
- ◁ c.00 appears in the display.
5. Press the or button to change the installer code.
 - Installer code: 17
6. Confirm by pressing .
7. Press to access the diagnostics codes (d.), the check programmes (P.) and the fault codes (F.) and to return to the diagnostics codes (d.).
8. Use or to set the required value .
 - ◁ ✓ appears in the display.
9. Confirm by pressing .
10. Use or to set the required value .
 - ◁ ✓ appears in the display if the value can be set.

◁ "no" appears in the display if the value cannot be set.

11. Confirm by pressing .
12. Press to cancel a setting or exit the installer level.

8.4 Using diagnostics codes

You can use the parameters marked as adjustable in the table of diagnostics codes to adapt the product to the installation and customer requirements.

8.4.1 Setting a diagnostics code

1. Call up the installer level. (→ Page 27)
 - ◁ d.-- is shown in the display.
2. Press the or button to select the diagnostics code.
3. Press to confirm.
4. Press the or button to set the value of the diagnostic code.
5. Press to confirm.
6. Press to return to the sequence.
 - ◁ The diagnostics codes are shown in the display once again.
7. Proceed accordingly for all parameters that need to be changed.
8. Press the button 2 times to exit the diagnostics code configuration.
 - ◁ The display switches to the basic display.

8.5 Displaying the status codes

The status codes display the product's current operating status.

Status codes – Overview (→ Page 50)

8.5.1 Live Monitor (status codes)

1. Press and ("i") at the same time.
 - ◁ The S.xx message appears in the display, followed by information about the installation (→ Activating access for the competent person).
2. Press .
- ◁ The display switches to the basic display.



8.6 Using check programmes

By activating various check programmes, you can trigger various special functions on the product.

Check programmes – Overview (→ Page 46)

8.6.1 Calling up the check programmes

1. Call up the installer level. (→ Page 27)
 - ◁ d.-- is shown in the display.
2. Press .
- ◁ P.-- is shown in the display.
3. Press the or button to select the check programme.
4. Press to confirm.
 - ◁ The check programme starts.
5. Press .
- ◁ The heating water temperature and the filling pressure for the heating installation are shown alternately in the display.

6. Press  to return to the check programme.
 - ◁ The display shows the check programme.
7. Press  to exit the check programme.
 - ◁ OFF is shown in the display.
 - ◁ The display changes to show the check programmes.
8. Press the  button 2 times to exit the check programme.
 - ◁ The End message appears in the display.
 - ◁ The display switches to the basic display.

9 Start-up

9.1 Carrying out the initial start-up

Initial start-up must be carried out by a customer service technician or an authorised competent person using the Benchmark Checklist. The Benchmark Checklist in the appendix (→ Page 55) of the installation instructions must be filled in and stored carefully along with the unit's documentation.

- ▶ Carry out the initial start-up using the Benchmark Checklist in the appendix.
- ▶ Fill out and sign the Benchmark Checklist.

9.2 Checking and treating the heating water/filling and supplementary water



Caution.

Risk of material damage due to poor-quality heating water

- ▶ Ensure that the heating water is of sufficient quality.

- ▶ Before filling or topping up the installation, check the quality of the heating water.

Checking the quality of the heating water

- ▶ Remove a little water from the heating circuit.
- ▶ Check the appearance of the heating water.
- ▶ If you ascertain that it contains sedimentary materials, you must desludge the installation.
- ▶ Use a magnetic rod to check whether it contains magnetite (iron oxide).
- ▶ If you ascertain that it contains magnetite, clean the installation and apply suitable corrosion-inhibition measures, or fit a magnetic filter.
- ▶ Check the pH value of the removed water at 25 °C.
- ▶ If the value is below 8.2 or above 10.0, clean the installation and treat the heating water.
- ▶ Ensure that oxygen cannot get into the heating water.

Checking the filling and supplementary water

- ▶ Before filling the installation, measure the hardness of the filling and supplementary water.

Treating the filling and supplementary water

- ▶ Observe all applicable national regulations and technical rules when treating the filling and supplementary water.

Provided the national regulations and technical rules do not stipulate more stringent requirements, the following applies:

You must treat the heating water in the following cases

- If the entire filling and supplementary water quantity during the operating life of the system exceeds three times the nominal volume of the heating installation, or
- If the guideline values listed in the following table are not met, or
- If the pH value of the heating water is less than 8.2 or more than 10.0.

Total heating output	Water hardness at specific system volume ¹⁾					
	≤ 20 l/kW		> 20 l/kW ≤ 50 l/kW		> 50 l/kW	
kW	ppm CaCO ₃	mol/m ³	ppm CaCO ₃	mol/m ³	ppm CaCO ₃	mol/m ³
< 50	< 300	< 3	200	2	2	0.02
> 50 to ≤ 200	200	2	150	1.5	2	0.02
> 200 to ≤ 600	150	1.5	2	0.02	2	0.02
> 600	2	0.02	2	0.02	2	0.02

1) Nominal capacity in litres/heating output; in the case of multi-boiler systems, the smallest single heating output is to be used.



Caution.

Risk of material damage if the heating water is treated with unsuitable additives.

Unsuitable additives may cause changes in the components, noises in heating mode and possibly subsequent damage.

- ▶ Do not use any unsuitable antifreeze and corrosion inhibitors, biocides or sealants.

No incompatibility with our products has been detected to date with proper use of the following additives.

- ▶ When using additives, follow the manufacturer's instructions without exception.

We accept no liability for the compatibility of any additive or its effectiveness in the rest of the heating system.

Additives for cleaning measures (subsequent flushing required)

- Adey MC3+
- Adey MC5
- Fernox F3
- Sentinel X 300
- Sentinel X 400

Additives intended to remain permanently in the installation

- Adey MC1+
- Fernox F1
- Fernox F2
- Sentinel X 100
- Sentinel X 200

Additives for frost protection intended to remain permanently in the installation

- Adey MC ZERO
- Fernox Antifreeze Alphi 11
- Sentinel X 500
- ▶ If you have used the above-mentioned additives, inform the end user about the measures that are required.
- ▶ Inform the end user about the measures required for frost protection.

9.3 Filling the condensate siphon

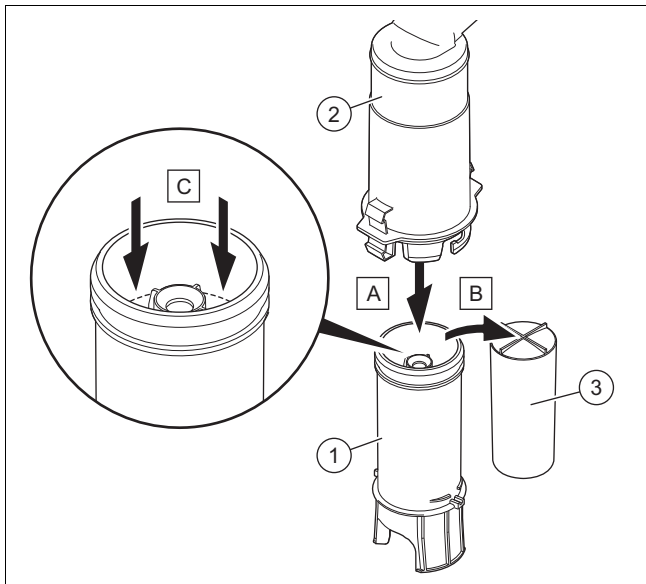

1. Unclip the lower section of the siphon (1) from the upper section of the siphon (2) without removing the product's front casing.
2. Remove the float (3).
3. Fill the lower section of the siphon with water up to 10 mm below the upper edge of the condensate discharge pipe.
4. Re-insert the float (3).



Note

Check that the float is present in the condensate siphon.

5. Clip the lower section of the siphon (1) into the upper section of the siphon (2).

9.4 Switching the product on and off

- ▶ Press the on/off button on the product.
 - ◀ The display shows the basic display.

9.5 Preventing low water pressure

The required filling pressure is between 0.08 and 0.2 MPa (0.8 and 2 bar).

If the water pressure falls below 0.05 MPa (0.5 bar), the value flashes in the display.

If the water pressure falls below 0.03 MPa (0.3 bar), the product switches off. The display shows 0.0 bar (0.0 MPa). Fault F22 is stored in the fault list.

- ▶ Top up the water in the heating installation to start up the product again.
 - ◀ The pressure value flashes in the display until a pressure of 0.05 MPa (0.5 bar) or higher has been reached.

9.6 Flushing the heating installation for the first time ("cold")



Note

The complete heating system must be flushed at least twice: Once with cold water and once with hot water in accordance with the following instructions.

1. Check whether all thermostatic radiator valves and both service valves on the product are open.
2. Connect a hose to the drain valve that is located at the lowest position in the heating system.
3. Open the radiator valves and the drain valves so that the water can drain quickly. Start at the next point in the installation and open the purging valves on the radiators so that the contaminated water can completely drain.
4. Close the draining cocks.
5. Refill the heating system with water.
6. Check that the expansion relief valve of the heating system is functioning correctly by turning the handle on the valve.
7. Check the pressure in the heating system and top up with water if necessary.
8. Close the filling valve and the cold water tap.

9.7 Filling and purging the heating installation

1. Flush the heating installation through.
2. Observe the information on the topic of treating (→ Page 29) heating water.

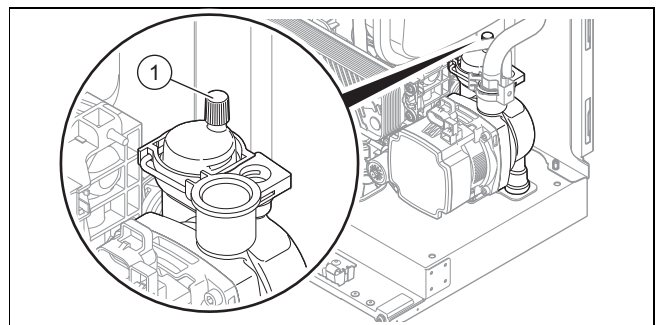

3. Undo the cap of the automatic air vent (1) by one to two rotations and leave it open, as the product purges itself via the automatic air vent even in continuous operation.
4. Open all thermostatic radiator valves.
5. Supply the heating circuit with water.
6. Check whether the stopcocks for the heating flow and return are open.
7. Start filling programme P.06.
Check programmes – Overview (→ Page 46)
 - ◀ The prioritising diverter valve is moved to the mid-position.
8. Fill with water until the required filling pressure is reached.

- Recommended filling pressure: 0.8 to 2 bar
 - ◁ The heating and domestic hot water function cannot be activated.
 - ◁ The pressure value flashes in the display until a pressure of 0.05 MPa (0.5 bar) or higher has been reached.
 - ◁ An automatic air vent function is activated if the pressure exceeds 0.07 MPa (0.7 bar) for longer than 15 seconds.
9. Purge each radiator until the water escapes normally, and then close the installation's purging valves.
 10. Check whether all connections are leak-tight.

Condition: If the noise persists in the boiler

- ▶ Purge the product again by activating check programme P.00.
- Check programmes – Overview (→ Page 46)

9.8 Filling the hot water circuit

1. Open the taps to fill the hot water circuit.
2. Close the taps once the required volume of water has flowed into the circuit.
 - ◁ The hot water circuit is filled.
3. Check all connections and the entire system for leak-tightness.

9.9 Checking the gas setting

Only a qualified competent person is authorised to implement the CO₂ setting on the gas valve assembly.

Each destroyed seal must be replaced.

The CO₂ adjusting screw must be sealed.

Never modify the factory setting of the gas pressure regulator of the gas valve assembly.

- ▶ Before you start up the product, compare the gas group information on the data plate with the gas group available at the installation site.

Condition: The product design is not compatible with the local gas group

Only Vaillant Service may perform a gas conversion.

If a gas conversion to liquefied petroleum gas has been carried out, the smallest possible partial load is higher than is shown on the display. The correct values can be found in the Technical data in the appendix.

- ▶ Call Vaillant Service (0330 1003 143).
- ▶ Do not start up the product.

Condition: The product design is compatible with the local gas group

- ▶ Proceed as described below.

9.9.1 Checking the air/flue pipe/flue gas recirculation

1. Check the flue gas installation is intact in accordance with the latest gas safe technical bulletin and information supplied in the installation instructions.
2. For extended flue gas installations check for flue gas recirculation using the air analysis point.
3. Use a flue gas analyser.
4. If you discover unusual levels of CO or CO₂ in the supply air, search for the leak in the flue system or for signs of flue gas recirculation.

5. Eliminate the damage properly.
6. Check again whether the supply air contains any unusual levels of CO or CO₂.
7. If you cannot eliminate the damage, do not start up the product.

9.9.2 Checking the gas flow rate

The gas flow rate has been set during production and does not require adjustment. With the front casing fitted check the gas flow rate of the boiler as follows:

- ▶ Start up the product with the check programme P.01.
- ▶ In addition, ensure that maximum heat can be dissipated into the heating system by turning up the room thermostat.
- ▶ Wait at least 5 minutes until the boiler has reached its operating temperature.
- ▶ Ensure that all other gas appliances in the property are turned off.
- ▶ Measure the gas flow rate at the gas meter.
- ▶ Compare the measured values with the corresponding values in the table.

Qnw from the data plate	H gas in m ³ /h			P gas in m ³ /h		
	Nom.	+5%	-10%	Nom.	+5%	-10%
24,4	2,58	2,71	2,32	1,90	2,00	1,71
28,5	3,02	3,17	2,72	2,21	2,32	1,99
34,6	3,66	3,84	3,29	2,69	2,82	2,42

Condition: Gas flow rate not in the permissible range

- ▶ Check all of the piping and ensure that the gas flow rates are correct.
- ▶ Only put the product into operation once the gas flow rates have been corrected.

Condition: Gas flow rate in the permissible range

- ▶ End the check programme P.01.
- ▶ Allow the boiler to cool down by allowing pump overrun to operate for a minimum of 2 minutes.
- ▶ Record the boiler maximum gas flow rate onto the Benchmark gas boiler commissioning checklist.

9.9.3 Checking the gas connection pressure (gas flow pressure)

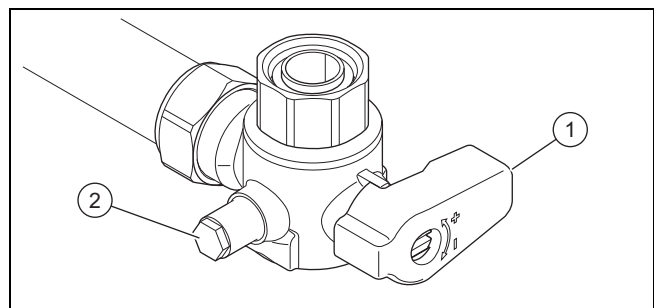

1. Ensure that the gas inlet working pressure can be obtained with all other gas appliances in the property working.
2. Close the gas stopcock (1).
3. Undo the sealing screw on the test nipple (2).
4. Connect a manometer to the test nipple (2).
5. Open the gas stopcock (1).
6. Start up the product with check programme P.01.

7. In addition, ensure that maximum heat can be dissipated into the heating system by turning up the room thermostat.
8. With the boiler operating at full load check that the gas inlet working pressure at the reference test point (2) complies with the requirements.

Permissible gas flow pressure for operation with	
Natural gas H	1.5 to 2.5 kPa (15.0 to 25.0 mbar)
Permissible gas flow pressure for operation with	
Liquefied petroleum gas P	2.5 to 4.5 kPa (25.0 to 45.0 mbar)

9. Should the pressure recorded at the reference test point in the boiler be lower than indicated check if there is any blockage in the pipework or if the pipework is undersized.

Condition: Gas flow pressure not in the permissible range



Caution.

Risk of material damage and operating faults caused by incorrect gas connection pressure.

If the gas connection pressure lies outside the permissible range, this can cause operating faults in and damage to the product.

- ▶ Do not make any adjustments to the product.
- ▶ Do not start up the product.

- ▶ If you cannot correct the failure, notify the gas supply company and proceed as follows:
- ▶ End the check programme P.01 or P.04.
- ▶ Allow the boiler to cool down by allowing pump overrun to operate for a minimum of two minutes.
- ▶ Close the gas stopcock.
- ▶ Remove the pressure gauge and retighten the sealing screw (2) for the measuring nipple.
- ▶ Open the gas stopcock (1).
- ▶ Check the test nipple for gas tightness.
- ▶ Close the gas stopcock (1).
- ▶ Disconnect the product from the power grid.
- ▶ You must not start up the boiler.

Condition: Gas flow pressure in the permissible range

- ▶ End the check programme P.01 or P.04.
- ▶ Allow the boiler to cool down allowing pump overrun to operate for a minimum of two minutes.
- ▶ Close the gas stopcock (1).
- ▶ Remove the pressure gauge and retighten the sealing screw (2) for the measuring nipple.
- ▶ Open the gas stopcock (1).
- ▶ Check the test nipple for gas tightness.
- ▶ Reset boiler controls for normal operation.
- ▶ Record the appliance gas inlet working pressure (kPa resp. mbar) in the Benchmark gas boiler commissioning checklist.

9.9.4 Checking the CO₂ content

1. Start up the product with the check programme and set the value.
 - Setting value for the programme P.01: 100
 Check programmes – Overview (→ Page 46)
2. Wait until the value that is read is stable.
 - Waiting period for reading a stable value: 5 min

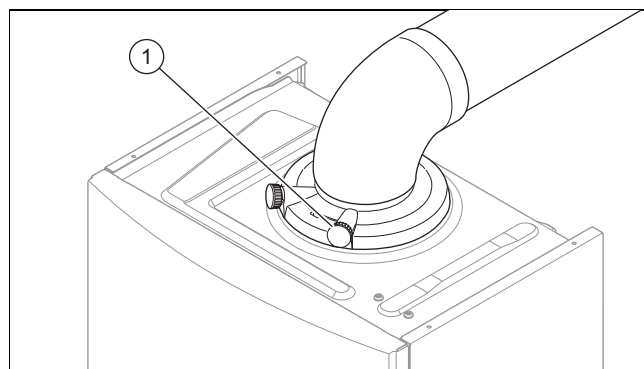

3. Unscrew the cover from the flue gas analysis point (1).
4. Measure the CO₂ content at the flue gas analysis point.
5. Compare the measured value with the corresponding value in the table.

Checking the CO ₂ content	Removed front casing	Fitted front casing
	Natural gas H	Natural gas H
CO ₂ at full load	9.0 ±1.0 vol. %	9.2 ±1.0 vol. %
CO at full load	≤ 250 ppm	≤ 250 ppm
CO/CO ₂	≤ 0.0031	≤ 0.0031

Checking the CO ₂ content	Removed front casing	Fitted front casing
	Liquefied petroleum gas P	Liquefied petroleum gas P
CO ₂ at full load	10.1 ±0.5 vol. %	10.3 ±0.5 vol. %
CO at full load	≤ 250 ppm	≤ 250 ppm
CO/CO ₂	≤ 0.0026	≤ 0.0026

- ◁ The value is OK.
- ▽ The value is not OK; you cannot start up the product.
 - ▶ Contact customer service.

9.10 Thoroughly flushing the heating installation ("hot")

1. Operate the appliance until the boiler and the heating system are up to temperature.
2. Check the heating system for leaks.
3. Connect a hose to the drain valve located at the lowest position of the heating system.
4. Shut off the boiler, open the drain valve and all purge valves on the radiators and allow the water to flow out of the heating system and the boiler quickly and fully.
5. Close the drain valve.
6. Fill the heating system again with water as described in Filling the heating installation and Purging the heating installation.
7. Re-fill the system until the system design pressure of 0,1 MPa (1,0 bar) is attained.



Note

The actual reading on the digital pressure gauge should ideally be 0,05 MPa (0,5 bar) plus an additional pressure corresponding to the highest point of the system above the base of the boiler – 10 m head equals an additional 1 bar reading on the pressure gauge. The minimum pressure should not be less than 0,1 MPa (1 bar) in any installation. If the system is to be treated with an inhibitor it should be applied at this stage in accordance with the manufacturer's instructions

8. Install the front casing.

9.11 Checking leak-tightness

- ▶ Check the gas pipe, the heating circuit and the hot water circuit for leak-tightness.
- ▶ Check that the flue system has been installed correctly.

9.11.1 Checking the heating mode

1. Activate the heating mode on the user interface.
2. Turn all thermostatic valves on the radiators until they are fully open.
3. Allow the product to operate for at least 15 minutes.
4. Fill and purge the heating installation. (→ Page 30)
5. Call up the status codes. (→ Page 27)
Status codes – Overview (→ Page 50)
 - ◁ If the product is working correctly, the display shows S.04.

9.11.2 Checking the hot water generation

1. Activate the hot water handling mode on the user interface.
2. Open a hot water valve completely.
3. Call up the status codes. (→ Page 27)
Status codes – Overview (→ Page 50)
 - ◁ If the product is working correctly, the display shows S.14.

10 Adapting the unit to the heating installation

10.1 Activating diagnostics codes

You can find the setting options in the diagnostics codes in the installer level.

- ▶ Set a diagnostics code. (→ Page 27)

10.2 Burner anti-cycling time

To prevent frequent switching on and off of the burner and thus prevent energy losses, an electronic restart lockout is activated for a specific period each time the burner is switched off. The burner anti-cycling time is only active for the heating mode. Switching on domestic hot water mode during the burner anti-cycling time has no effect.

10.2.1 Setting the maximum burner anti-cycling time

1. Set a diagnostics code. (→ Page 27)

T _{Flow} (target) [°C]	Set maximum burner anti-cycling time [min]						
	1	5	10	15	20	25	30
30	2.0	4.0	8.5	12.5	16.5	20.5	25.0
35	2.0	4.0	7.5	11.0	15.0	18.5	22.0
40	2.0	3.5	6.5	10.0	13.0	16.5	19.5
45	2.0	3.0	6.0	8.5	11.5	14.0	17.0
50	2.0	3.0	5.0	7.5	9.5	12.0	14.0
55	2.0	2.5	4.5	6.0	8.0	10.0	11.5
60	2.0	2.0	3.5	5.0	6.0	7.5	9.0
65	2.0	1.5	2.5	3.5	4.5	5.5	6.5
70	2.0	1.5	2.0	2.5	2.5	3.0	3.5
75	2.0	1.0	1.0	1.0	1.0	1.0	1.0

T _{Flow} (target) [°C]	Set maximum burner anti-cycling time [min]					
	35	40	45	50	55	60
30	29.0	33.0	37.0	41.0	45.0	49.5
35	25.5	29.5	33.0	36.5	40.5	44.0
40	22.5	26.0	29.0	32.0	35.5	38.5
45	19.5	22.5	25.0	27.5	30.5	33.0
50	16.5	18.5	21.0	23.5	25.5	28.0
55	13.5	15.0	17.0	19.0	20.5	22.5
60	10.5	11.5	13.0	14.5	15.5	17.0
65	7.0	8.0	9.0	10.0	11.0	11.5
70	4.0	4.5	5.0	5.5	6.0	6.5
75	1.0	1.0	1.0	1.0	1.0	1.0

2. If required, adjust the maximum burner anti-cycling time using diagnostics code d.02.

10.2.2 Resetting the remaining burner anti-cycling time

- ▶ Press and hold the button for more than three seconds.
 - ◁ All symbols are shown in the display.

10.3 Setting the maximum heating output

The product's maximum heating output is set to automatic mode at the factory. If you want to set your own fixed maximum heating output, however, you can specify a value under d.00 which equates to the product output in kW.

10.4 Setting the maintenance interval

If you set the maintenance interval, after a configurable number of burner operating hours, the message that the product must be serviced appears in the display, together with the maintenance symbol .

- Use diagnostics code d.84 to set the number of operating hours until the next maintenance is due (number of operating hours = display value x 10). Guideline values can be found in the following table.

Heat demand	Number of persons	Guideline value for burner operating hours until the next inspection/maintenance work is due for an average operating time of one year (dependent upon the system type)
5.0 kW	1 - 2	1050 h
	2 - 3	1150 h
10.0 kW	1 - 2	1500 h
	2 - 3	1600 h
15.0 kW	2 - 3	1800 h
	3 - 4	1900 h
20.0 kW	3 - 4	2600 h
	4 - 5	2700 h
25.0 kW	3 - 4	2800 h
	4 - 6	2900 h
> 27.0 kW	3 - 4	3000 h
	4 - 6	3000 h

The values stated correspond to an average operating time of one year.

If you do not set a numerical value but do set the symbol "---", the function is not active.



Note

On completion of the set operating hours, you must set the maintenance interval again.

10.5 Setting the pump output

Validity: VUW 246/7-2 (H-GB) OR VUW 286/7-2 (H-GB) OR VUW 346/7-2 (H-GB)

The product is equipped with a speed-regulated high-efficiency pump, which adjusts independently to the hydraulic conditions of the heating installation.

If you have installed a low loss header in the heating installation, we recommend switching off the speed regulation and setting the pump output to a fixed value.

- If required, change the setting of the pump speed, which depends on the operating mode, under diagnostics code d.14.

Remaining pump head

Pump curve

Validity: VUW 246/7-2 (H-GB) OR VUW 286/7-2 (H-GB)

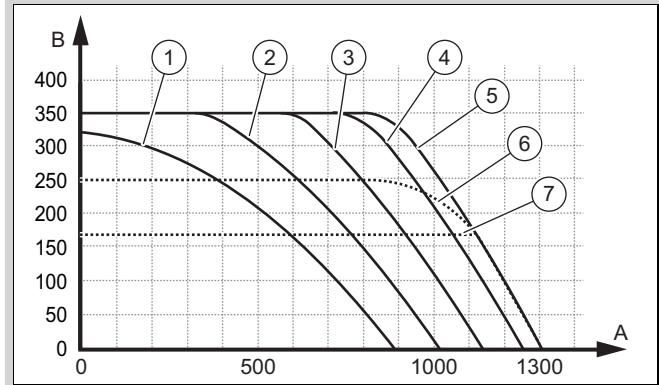

- | | | | |
|---|----------------|---|--------------------------------|
| 1 | PWM 65% | 6 | Bypass setting: 250 hPa (mbar) |
| 2 | PWM 73% | 7 | Bypass setting: 170 hPa (mbar) |
| 3 | PWM 80% | A | Flow rate (l/h) |
| 4 | PWM 88% | B | Remaining feed head (hPa) |
| 5 | PWM 95 to 100% | | |

Pump curve

Validity: VUW 346/7-2 (H-GB)

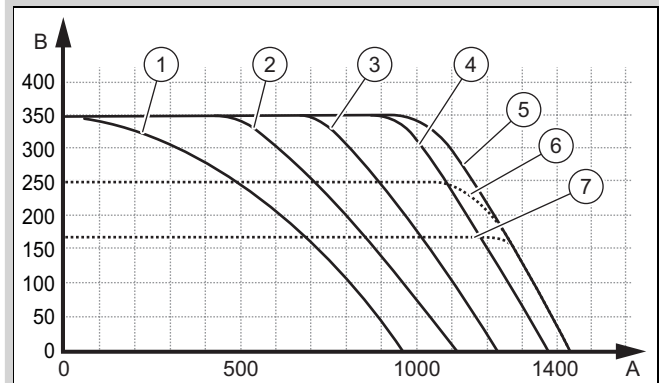

- | | | | |
|---|----------------|---|--------------------------------|
| 1 | PWM 65% | 6 | Bypass setting: 250 hPa (mbar) |
| 2 | PWM 73% | 7 | Bypass setting: 170 hPa (mbar) |
| 3 | PWM 80% | A | Flow rate (l/h) |
| 4 | PWM 88% | B | Remaining feed head (hPa) |
| 5 | PWM 95 to 100% | | |

10.6 Setting the bypass



Caution.

Risk of material damage caused by incorrect setting of the high-efficiency pump

If the pressure at the bypass is increased (by turning clockwise) and the pump output is set to less than 100%, the product may not operate correctly.

- In this case, set the pump output to 5 = 100% using diagnostics code d.14.

- Remove the front casing. (→ Page 18)

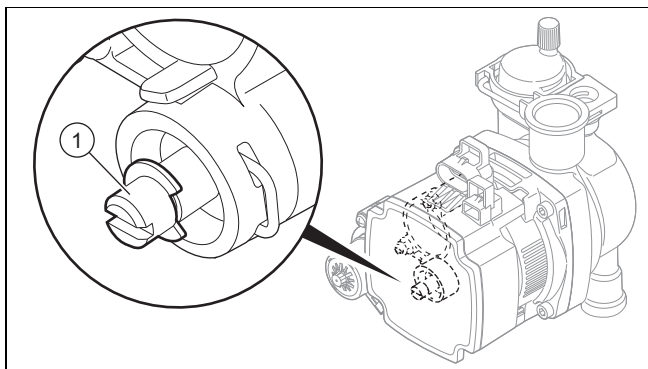

- ▶ Regulate the pressure using the adjusting screw (1).

Position of the adjusting screw	Pressure in MPa (mbar)	Notes/application
Right-hand stop (turned all the way down)	0.035 (350)	If the radiators do not heat up sufficiently at the default setting. In this case, you must set the pump to the maximum speed.
Mid-position (six anti-clockwise rotations)	0.025 (250)	Default setting
Five further anti-clockwise rotations starting from the mid-position	0.017 (170)	If noises are produced in the radiators or radiator valves

- ▶ Install the front casing.

10.7 Setting the domestic hot water temperature



Danger!

Risk of death from legionella.

Legionella multiply at temperatures below 60 °C.

- ▶ Ensure that the end user is familiar with all of the Anti-legionella measures in order to comply with the applicable regulations regarding legionella prevention.

1. Set the domestic hot water temperature.

Condition: Water hardness: > 3.57 mol/m³

- Domestic hot water temperature: ≤ 50 °C

2. Descale the water as required.
3. Observe the applicable regulations regarding legionella prevention.

11 Handing over to the end user

- ▶ At the time of commissioning complete all relevant sections of the Benchmark commissioning checklist, located at the rear of this document.
- ▶ For IE: Complete a "Declaration of Conformity" to indicate compliance to I.S. 813. An example of this is given in the current edition of I.S. 813.
- ▶ When you have finished the installation, affix the enclosed sticker (which requests that the user reads the instructions) to the front of the product in the end user's language.
- ▶ Draw attention, to the current issue of the Gas Safety (Installation and Use) Regulations, Section 35, which imposes a duty of care on all persons who let out any property containing a gas appliance in the UK.
- ▶ Explain to the end user how the safety devices work and where they are located.
- ▶ Inform the end user how to handle the product.
- ▶ In particular, draw attention to the safety warnings that the end user must follow.
- ▶ Inform the end user that they must have the product maintained in accordance with the specified intervals.
- ▶ Pass all of the instructions and documentation for the product to the end user for safe-keeping.
- ▶ Inform the end user about measures taken to ensure the supply of combustion air and flue gas guiding, and instruct the operator that he must not make any changes.
- ▶ Inform the end user that they must not store or use explosive or highly flammable substances (such as petrol, paper or paint) in the installation room of the product.
- ▶ Complete and sign off the Benchmark commissioning check list.
- ▶ Complete and sign off the guarantee documentation.

12 Inspection and maintenance

12.1 Complete Service Interval Record section

- ▶ After servicing, complete the relevant Service Interval Record section of the Benchmark Checklist located on the inside back pages of this document.

12.2 Using original seals

If you replace components, use only the enclosed original seals; additional sealing materials are not required.

12.3 Inspection and maintenance

- ▶ You must carry out an annual inspection of the product. The annual inspection can be effectively performed without removing components by requesting data from the DIA system, carrying out the simple visual checks indicated in the table in the appendix and performing a flue gas measurement. The maintenance intervals and their scope are determined by the heating engineer based on the condition of the boiler found during the inspection. All inspection and maintenance work should be performed in the order specified in the table in the appendix.

During any inspection and maintenance or after change of parts of the combustion circuit, the following must be checked:

- The boiler has been installed in accordance with the relevant installation instructions.
- The integrity of the flue gas installation and flue seals is in accordance with the relevant flue installation instructions enclosed.
- Visual, the integrity of the boiler combustion circuit and relevant seals (paying particular attention to the burner door seal).
- The gas inlet working pressure at maximum rate.
- The gas flow rates.
- Correctness of electrical, water and gas connections.
- Correctness of the water pressure.
- The condition of the whole system, in particular the condition of radiator valves, evidence of leakage from the heating system and dripping taps.
- ▶ Correct any faults before proceeding.

12.4 Preparing the maintenance work

1. Switch off the product.
2. Disconnect the product from the power grid.
3. Remove the front casing. (→ Page 18)
4. Close the gas stopcock.
5. Close the service valves in the heating flow and in the heating return.
6. Close the service valve in the cold water pipe.
7. Drain the product to clean hydraulic components (→ Page 40).
8. Ensure that water does not drip on live components (e.g. the electronics box).
9. Use only new seals and o'ring. Do not use additional compounds.

12.5 Checking the CO₂ content

1. Start up the product with the check programme (P.01) and set the value.
 - Setting value for the programme P.01: 100
2. Wait until the value that is read is stable.
 - Waiting period for reading a stable value: 5 min

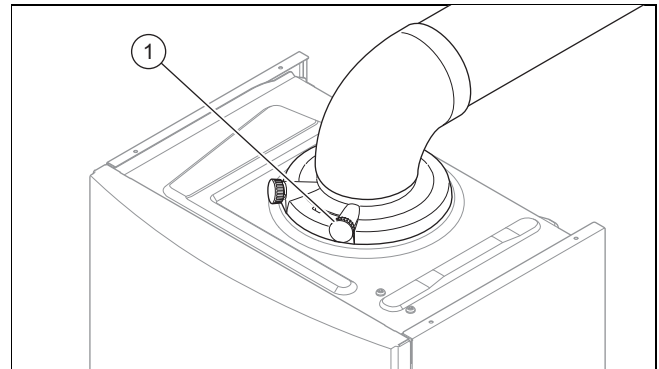

3. Unscrew the cover from the flue gas analysis point (1).
4. Measure the CO₂ content at the flue gas analysis point.
5. Compare the measured value with the corresponding value in the table.

Checking the CO ₂ content	Removed front casing	Fitted front casing
	Natural gas H	Natural gas H
CO ₂ at full load	9.0 ±1.0 vol. %	9.2 ±1.0 vol. %
CO at full load	≤ 250 ppm	≤ 250 ppm
CO/CO ₂	≤ 0.0031	≤ 0.0031

Checking the CO ₂ content	Removed front casing	Fitted front casing
	Liquefied petroleum gas P	Liquefied petroleum gas P
CO ₂ at full load	10.1 ±0.5 vol. %	10.3 ±0.5 vol. %
CO at full load	≤ 250 ppm	≤ 250 ppm
CO/CO ₂	≤ 0.0026	≤ 0.0026

- ◁ The value is OK.
- ▽ The value is not OK; you cannot start up the product.
 - ▶ Set the CO₂ content. (→ Page 37)

12.6 Setting the CO₂ content

Condition: The CO₂ content must be adjusted

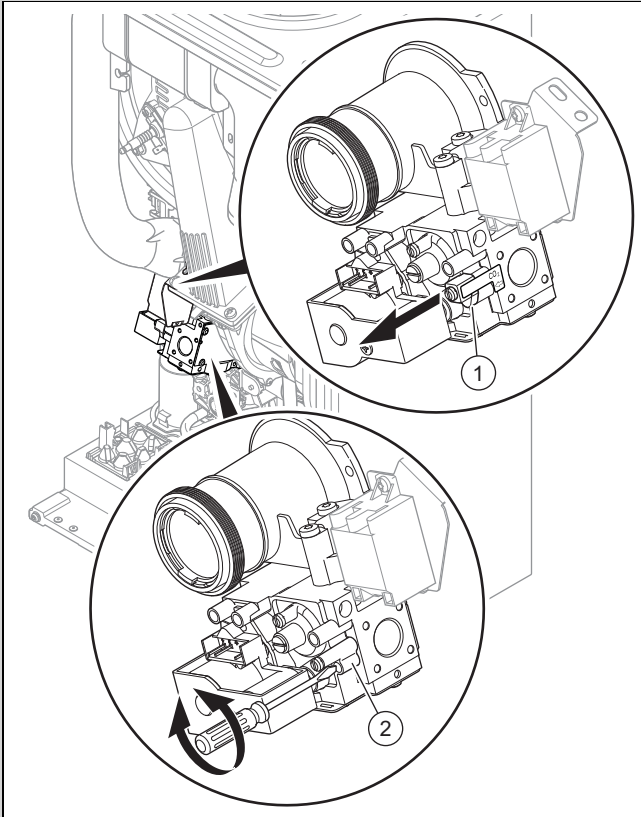

- ▶ Remove the sticker.
- ▶ Remove the covering cap (1).
- ▶ Turn the screw (2) to set the CO₂ content (value with front casing removed).
 - ◀ To increase the CO₂ content: Turn anti-clockwise
 - ◀ To decrease the CO₂ content: Turn clockwise



Note

For natural gas only: Only perform the adjustment in small increments of a 1/8 turn and wait approx. one minute after each adjustment until the value stabilises.

For liquefied petroleum gas only: Only perform the adjustment in extremely small increments (approx. 1/16 turn), and wait approx. one minute after each adjustment until the value stabilises.

- ▶ Compare the measured value with the corresponding value in the table.

Setting the CO ₂ content	Removed front casing	Fitted front casing
	Natural gas H	Natural gas H
CO ₂ at full load	9.0 ±0.2 vol. %	9.2 ±0.2 vol. %
Set for Wobbe index W ₀	14.09 kW-h/m ³	14.09 kW-h/m ³
O ₂ at full load		4.5 ±1.8 vol. %
CO at full load	≤ 250 ppm	≤ 250 ppm
CO/CO ₂	≤ 0.0028	≤ 0.0028

Setting the CO ₂ content	Removed front casing	Fitted front casing
	Liquefied petroleum gas P	Liquefied petroleum gas P
CO ₂ at full load	10.1 ±0.2 vol. %	10.3 ±0.2 vol. %
Set for Wobbe index W ₀	21.34 kW-h/m ³	21.34 kW-h/m ³
O ₂ at full load		5.1 ±0.8 vol. %
CO at full load	≤ 250 ppm	≤ 250 ppm
CO/CO ₂	≤ 0.0025	≤ 0.0025

- ▽ If the setting is not in the specified adjustment range, you must not start up the product.
 - ▶ Contact customer service.
- ▶ Check whether the air-quality requirements with regard to carbon monoxide are fulfilled.
- ▶ Refit the covering cap.
- ▶ Install the front panel.

12.7 Removing the compact thermal module



Note

The compact thermal module consists of four main components:

- Speed-regulated fan,
- Gas-air mixture unit,
- Gas supply (mixture pipe) with burner flange,
- Premix burner.



Danger!

Risk of death and risk of material damage caused by hot flue gas.

The seal, insulating mat and self-locking nuts on the burner flange must not be damaged. Otherwise, hot flue gases may escape and cause personal injury and material damage.

- ▶ Replace the seal each time you open the burner flange.
- ▶ Replace the self-locking nuts on the burner flange each time you open the burner flange.
- ▶ If the insulating mat on the burner flange or on the back wall of the heat exchanger shows signs of damage, replace the insulating mat.

1. Switch off the product using the on/off button.
2. Close the gas stopcock.
3. Remove the front casing.
4. Tilt the electronics box forwards.

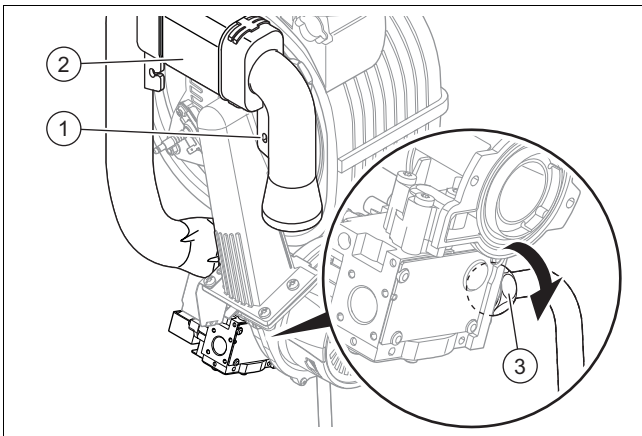

5. Unscrew the retaining screw (1) and remove the air intake pipe (2) from the intake stub.
6. Unscrew the union nut from the gas valve assembly (3).

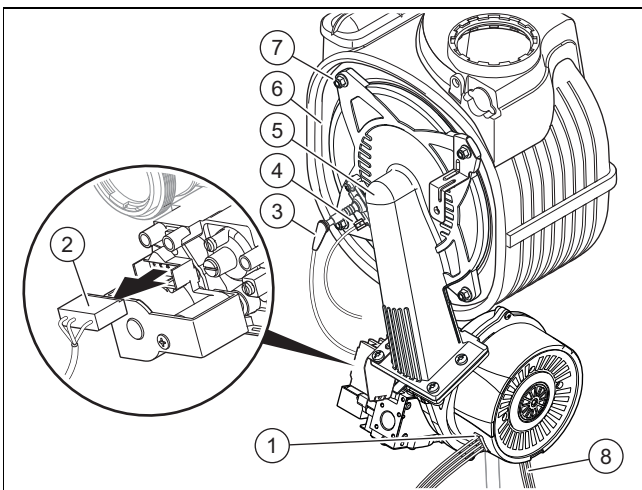

7. Remove the ignition line plug (3) and the earth wire plug (4) from the ignition electrode.
8. Remove the plugs (1) and (8) from the fan motor.
9. Remove the plug (2) from the gas valve assembly.
10. Unscrew the four nuts (7).
11. Remove the entire compact thermal module (5) from the heat exchanger (6).
12. Check the burner and the heat exchanger for damage and dirt.
13. If necessary, clean or replace the components according to the following sections.
14. Fit a new burner flange seal.
15. Check the insulating mat on the burner flange and on the back panel of the heat exchanger. If you notice any signs of damage, replace the relevant insulating mat.

12.8 Cleaning the heat exchanger

1. Protect the open electronics box from spraying water.

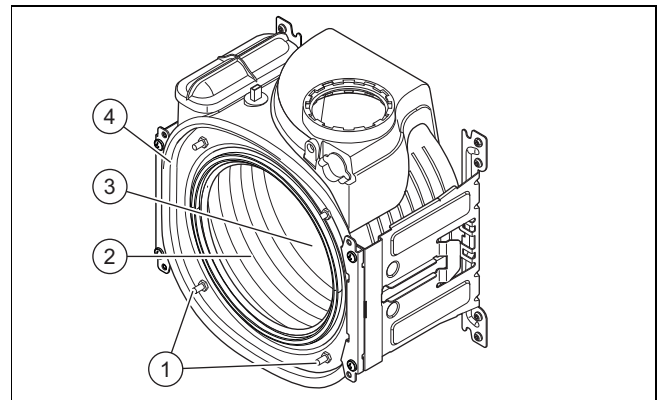

2. Do not undo the four nuts on the threaded pins (1), otherwise the tightness of the burner during set-up cannot be guaranteed.
3. Clean the spiral immersion heater (3) of the heat exchanger (4) using water or, if required, vinegar (up to a maximum acid content of 5%). Allow the vinegar to act on the heat exchanger for 20 minutes.
4. Rinse away any loose dirt with a sharp jet of water or use a plastic brush. Do not point the jet of water directly at the insulating mat (2) on the rear of the heat exchanger.
 - ◁ The water flows out of the heat exchanger through the condensate siphon.

12.9 Checking the burner

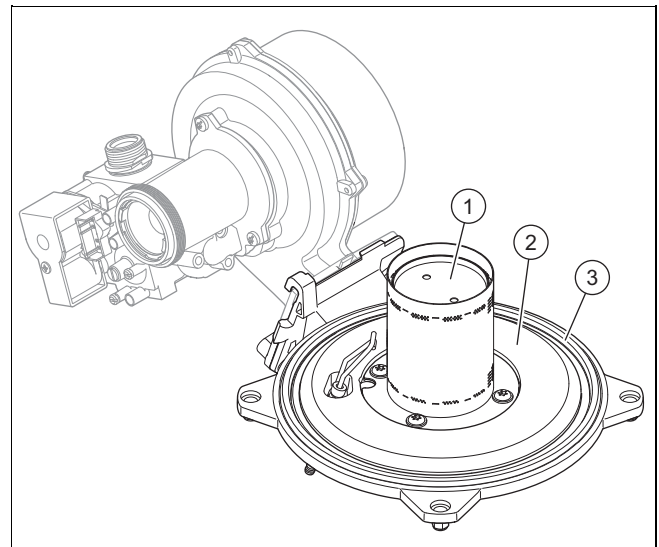

1. Check the surface of the burner (1) for damage. If any damage is found, replace the burner.
2. Fit a new burner flange seal (2).
3. Check the insulating mat (2) on the burner flange. If you discover any signs of damage, replace the insulating mat.

12.10 Cleaning the condensate siphon

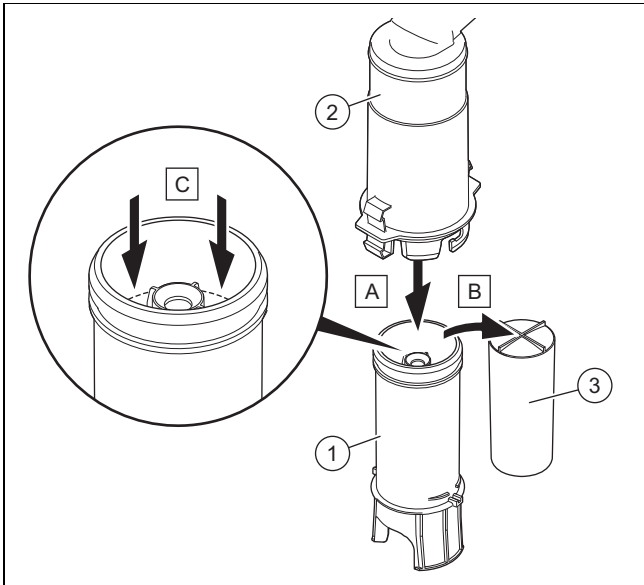

1. Unclip the lower section of the siphon (1) from the upper section of the siphon (2).
2. Remove the float (3).
3. Flush out the float and lower section of the siphon with water.
4. Fill the lower section of the siphon with water up to 10 mm below the upper edge of the condensate discharge pipe.
5. Re-insert the float (3).



Note

Check that the float is present in the condensate siphon.

6. Clip the lower section of the siphon (1) into the upper section of the siphon (2).

12.11 Cleaning the strainer in the cold water inlet

Validity: Product with integrated hot water generation

1. Close the main cold water line.
2. Drain the product on the domestic hot water side.
3. Remove the connector from the connection for the product's cold water pipe.
4. Clean the strainer in the cold water inlet without removing it.

12.12 Cleaning the heating filter

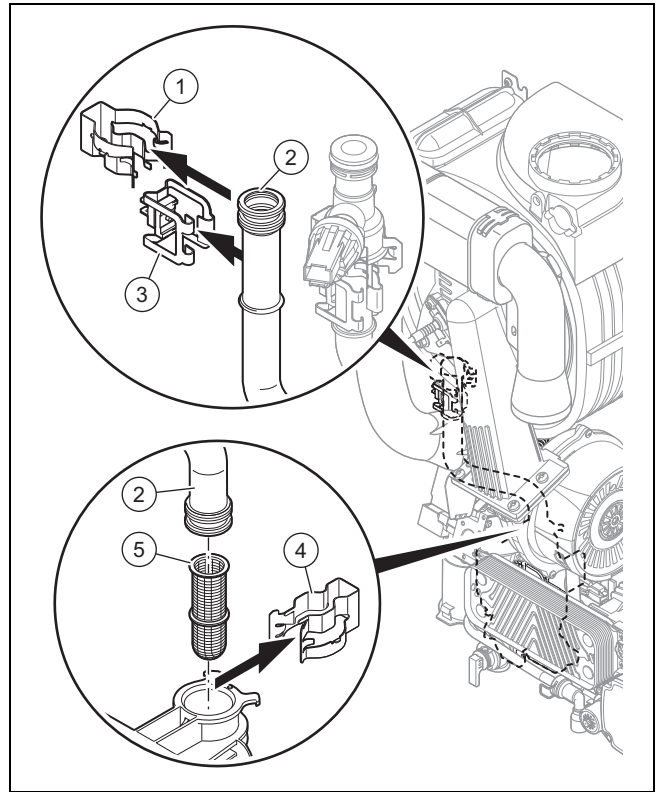

1. Drain the product. (→ Page 40)
2. Remove the temperature sensor (3).
3. Remove the upper clip (1).
4. Remove the lower clip (4).
5. Remove the flow pipe (2).
6. Remove the heating filter (5) and clean it.
7. When reinstalling the components, carry out the steps described above in reverse.

12.13 Installing the compact thermal module

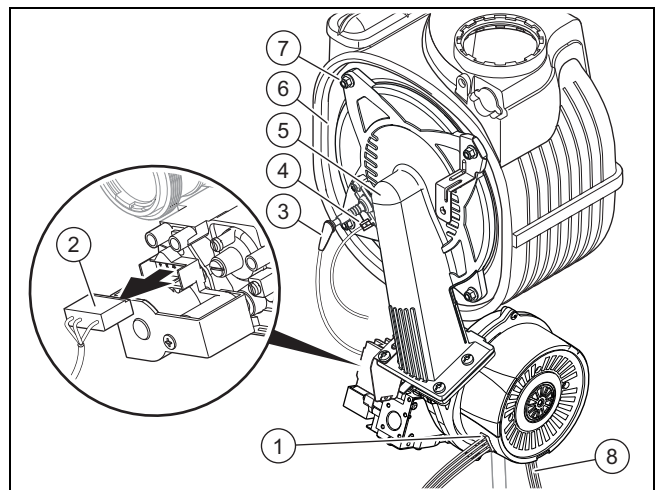

1. Connect the compact thermal module (5) to the heat exchanger (6).
2. Tighten the four nuts (7) in a cross-wise pattern until the burner flange fits closely and uniformly onto the mating surfaces.

- Tightening torque: 6 Nm, if a torque spanner is available.
3. Reconnect the plugs (1) to (4) and (8).
 4. Connect the gas pipe using a new seal. In the process, secure the gas pipe against twisting.
 5. Open the gas stopcock.
 6. Make sure that there are no leaks.
 7. Check that the sealing ring in the air intake pipe is positioned correctly in the seal seat.
 8. Reconnect the air intake pipe to the intake stub.
 9. Secure the air intake pipe with the retaining screw.
 10. Check the gas flow pressure.

12.14 Draining the product

1. Close the service valves of the product.
2. Start check programme P.06 (prioritising diverter valve mid-position).
3. Open the draining cock.
4. Make sure that the cap of the automatic air vent on the internal pump is open so that the product can be drained fully.

12.15 Checking the admission pressure of the expansion vessel

1. Drain the product. (→ Page 40)
2. Measure the pre-charge pressure of the expansion vessel at the vessel valve.

Condition: Pre-charge pressure < 0.075 MPa (0.75 bar)

- ▶ Fill the expansion vessel in accordance with the static height of the heating installation; ideally with nitrogen, otherwise with air.
 - ▶ Ensure that the drain valve is open when filling.
3. If water escapes from the valve of the expansion vessel, replace the expansion vessel (→ Page 42).
 4. Fill and purge the heating installation. (→ Page 30)

12.16 Completing inspection and maintenance work

- ▶ Start a test operation after the maintenance.
- ▶ Check the heating mode and, if required, the domestic hot water generation (if available).
- ▶ Check the gas connection pressure (gas flow pressure). (→ Page 31)
- ▶ Check the CO₂ content. (→ Page 32)
- ▶ If required, reset the maintenance interval. (→ Page 34)
- ▶ Install the front casing.
- ▶ Fill out the relevant Service Record section in the Benchmark Checklist.

12.17 Checking the product for leak-tightness

- ▶ Check that the product is leak-tight. (→ Page 33)

13 Troubleshooting

13.1 Checking service messages

 appears, for example, if you have set a maintenance interval and this has passed or if a service message has been issued. The product is not in fault mode.

- ▶ Call up the Live Monitor. (→ Page 27)

Condition: S.46 is displayed.

The product is in Comfort protection mode. The product continues to run with restricted comfort after it has detected a fault.

- ▶ To establish whether or not a component is defective, read the fault memory. (→ Page 40)



Note

If no fault message is present, the product will automatically switch back to normal operating mode after a certain time.

13.2 Rectifying faults

- ▶ If fault codes (F.XX) are present, refer to the table in the appendix for advice or use the check programme(s). Overview of fault codes (→ Page 51)
Check programmes – Overview (→ Page 46)





If several faults occur at the same time, the fault codes are shown alternately on the display.

Resetting the product:

- ▶ Press and hold the  button for more than three seconds.
 - ◀ The product restarts.
- ▶ If you are unable to clear the fault code and it reappears despite several fault clearance attempts, contact customer service.

13.3 Calling up the fault memory

The last ten fault codes are stored in the fault memory.

- ▶ Call up the installer level. (→ Page 27)
 - ◀ d.-- is shown in the display.
- ▶ Press the  button 2 times.
 - ◀ F.XX is shown in the display.
- ▶ Press the  and  buttons to call up the fault codes. Overview of fault codes (→ Page 51)
 - ◀ The fault code and the time of occurrence are shown alternately on the display.
- ▶ Press .
 - ◀ The display switches to the basic display.

13.4 Deleting the fault memory

1. Clear the fault memory using diagnostics code d.94.
2. Set a diagnostics code. (→ Page 27)

13.5 Resetting parameters to factory settings

1. Reset all parameters to the factory settings using diagnostics code d.96.
2. Set a diagnostics code. (→ Page 27)

13.6 Preparing the repair work

1. Decommission the product.
2. Disconnect the product from the power grid.
3. Remove the front casing. (→ Page 18)
4. Close the gas stopcock.
5. Close the service valves in the heating flow and in the heating return.
6. Close the service valve in the cold water pipe.
7. Drain the product to replace hydraulic components (→ Page 40).
8. Ensure that water does not drip on live components (e.g. the electronics box).
9. Use only new seals and o'ring. Do not use additional compounds.

13.6.1 Procuring spare parts

The original components of the product were also certified by the manufacturer as part of the declaration of conformity. If you use other, non-certified or unauthorised parts during maintenance or repair work, this may void the conformity of the product and it will therefore no longer comply with the applicable standards.

We strongly recommend that you use original spare parts from the manufacturer as this guarantees fault-free and safe operation of the product. To receive information about the available original spare parts, contact the contact address provided on the back page of these instructions.

- If you require spare parts for maintenance or repair work, use only the spare parts that are permitted for the product.

13.7 Replacing defective components

13.7.1 Replacing the burner

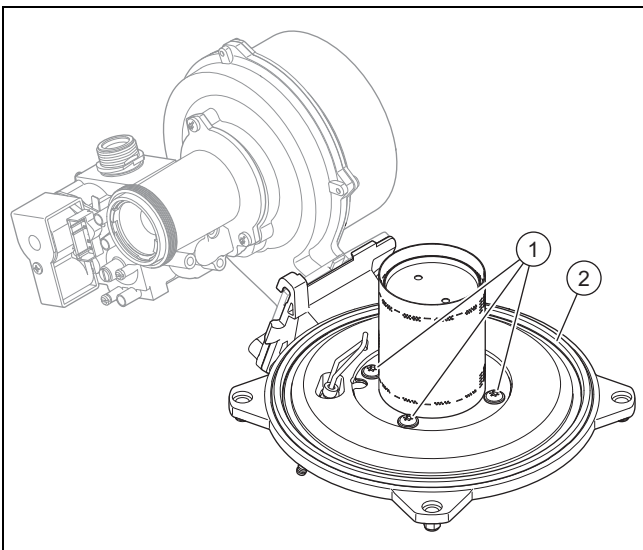

1. Undo the four screws (1) on the burner.

2. Remove the burner.
3. Install a new seal (2) on the new burner.

13.7.2 Replacing the fan or gas valve assembly

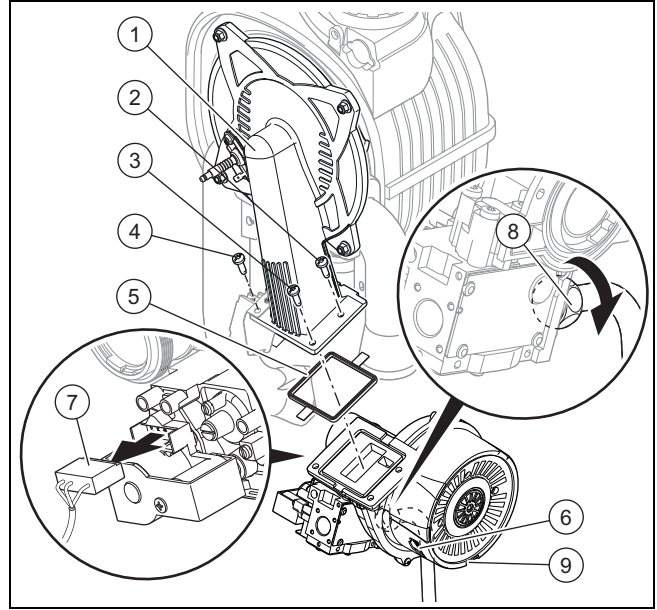

1. Remove the air intake pipe.
2. Remove the plug from the gas valve assembly (7).
3. Remove the plugs (6) and (9) from the fan motor by pushing in the latching lug.
4. Unscrew the connection from the gas valve assembly (8).
5. Unscrew the three screws (2)-(4) between the mixture pipe (1) and the fan flange.

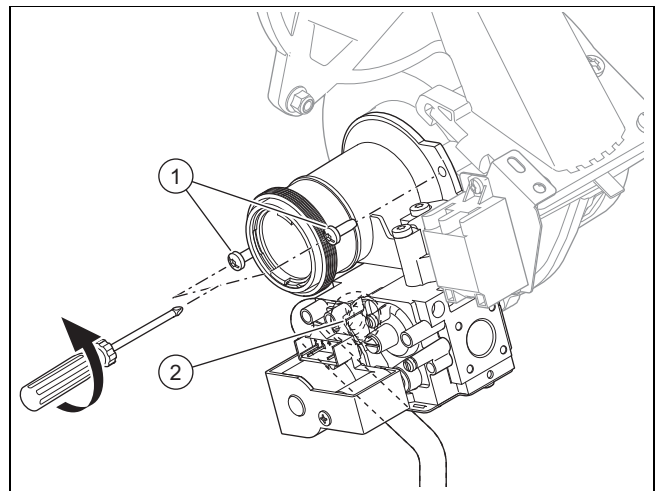

6. Remove the entire fan/gas valve assembly unit from the product.
7. Unscrew both fixing screws (1) on the gas valve assembly and remove the fan from the gas valve assembly.
8. Replace the defective fan or the defective gas valve assembly.
9. Install the gas valve assembly and the fan in the same position as before. Use new seals for this.
10. Screw the fan to the gas valve assembly.
11. If you had removed the gas pipe, screw the union nut of the gas pipe (2) only loosely to the gas valve assembly. Only tighten the union nut on the gas valve assembly after the installation work has been completed.

12. Refit the entire fan/gas valve assembly unit in reverse order. You must use a new seal **(5)** for this.
13. Ensure that the order in which the three screws are screwed in between the fan and the mixture pipe corresponds to the numbering **(3)**, **(2)** and **(4)**.
14. Tighten the union nut **(2)** on the gas valve assembly and the union nut **(8)** between the gas pipes. In the process, secure the gas pipe against twisting. Use new seals for this.
15. After you have completed this work, carry out a leak-tightness test (function check). (→ Page 33)
16. If you have installed a new gas valve assembly, adjust the gas setting. (→ Page 37)

13.7.3 Replacing the heat exchanger

1. Drain the product. (→ Page 40)
2. Detach the condensate discharge hose from the heat exchanger.

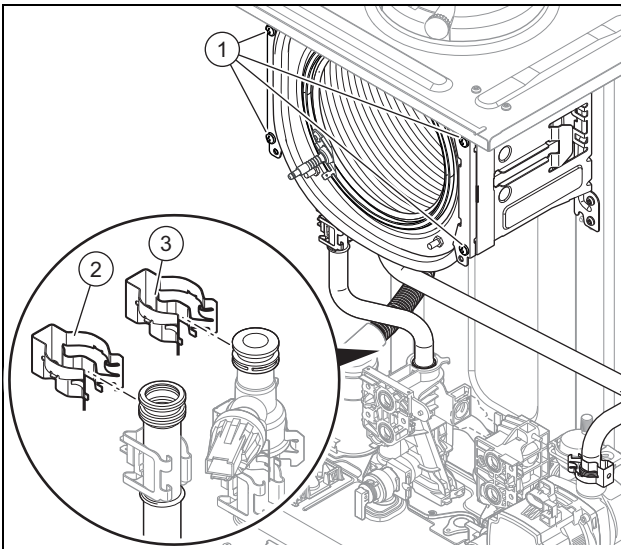

3. Remove the clamps **(2)** and **(3)** from the area of the flow and return connection.
4. Disconnect the flow connection.
5. Disconnect the return connection.
6. Remove both screws **(1)** from both brackets.

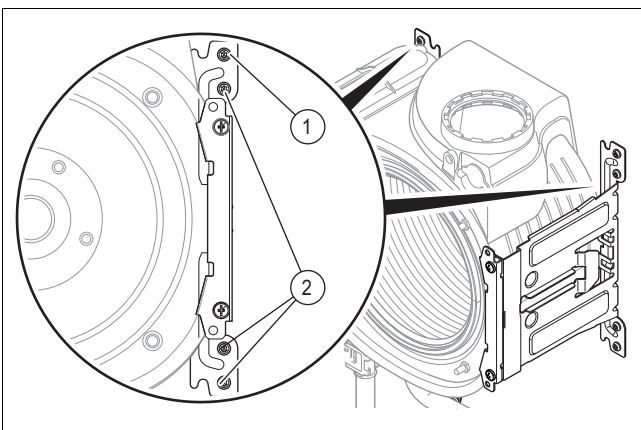

7. Remove the lower three screws **(2)** on the rear section of the retainer.
8. Move the bracket round to the opposite side and attach the upper screw **(1)** to the side.
9. Pull the heat exchanger downwards and to the right, and remove it from the product.
10. Install the new heat exchanger in reverse order.

11. Replace the seals.



Note

Instead of grease, use only water or commercially available soft soap to aid installation.

12. Insert the flow and return connections into the heat exchanger as far as they will go.
13. Ensure that the clamps are correctly fitted to the flow and return connections.
14. Fill and purge the unit and, if required, the heating installation. (→ Page 30)

13.7.4 Replacing the expansion vessel

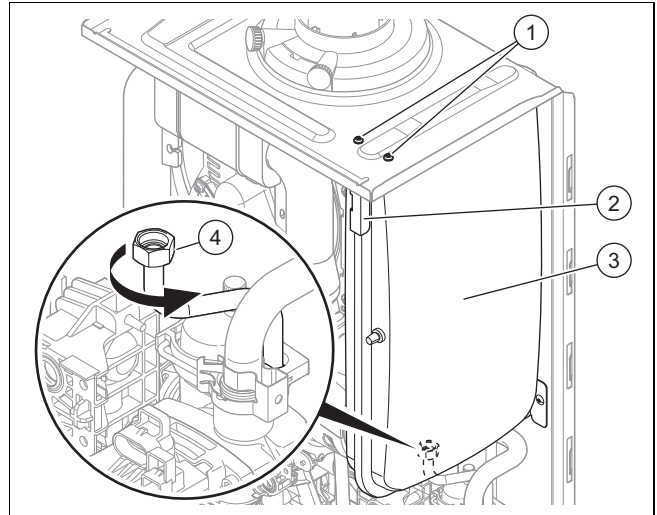

1. Prepare the repair work. (→ Page 41)
2. Undo the screwed connection **(4)**.
3. Remove both screws **(1)** on the support plate **(2)**.
4. Remove the support plate **(2)**.
5. Pull out the expansion vessel **(3)** towards the front.
6. Insert the new expansion vessel into the product.
7. Screw the new expansion vessel to the water connection. Use a new seal for this.
8. Attach the support plate using both screws **(1)**.
9. Fill and purge the product and, if required, the heating installation (→ Page 30).
10. If necessary, adjust the pressure to the static height of the heating installation.
11. Complete the repair work. (→ Page 44)

13.7.5 Replacing the expansion relief valve

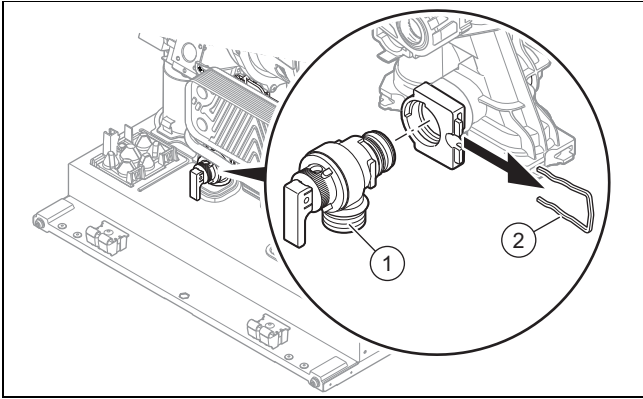

1. Remove the clip (2).
2. Remove the expansion relief valve.
3. Fit the new expansion relief valve with a new O-ring.
4. Reattach the clip (2).

13.7.6 Replacing the volume flow sensor

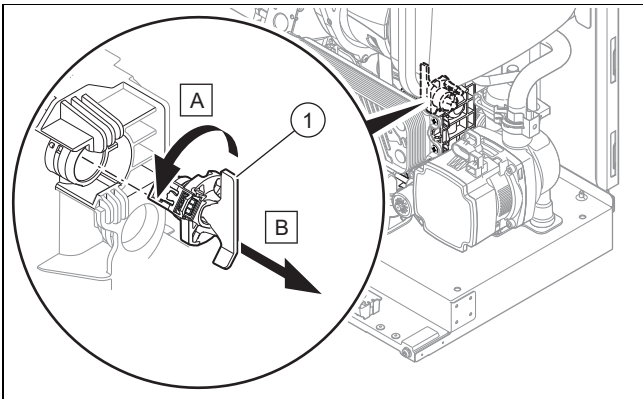

1. Pull out the plug.
2. Remove the volume flow sensor (1).
3. Install the new volume flow sensor.
4. Plug in the plug.

13.7.7 Replace the pressure sensor

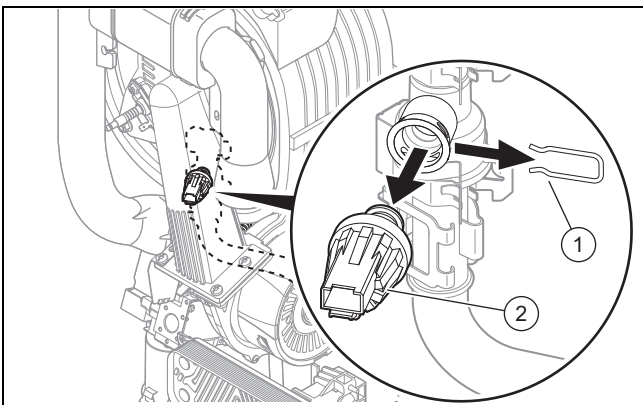

1. Remove the air intake pipe.
2. Protect the gas valve assembly from escaping water.
3. Remove the clip (1).
4. Remove the pressure sensor (2).
5. Remove the plug from the pressure sensor.
6. Connect the plug to the new pressure sensor.
7. Install the new pressure sensor.
8. Reattach the clip (1).

9. Install the air intake pipe.

13.7.8 Replacing the PCB

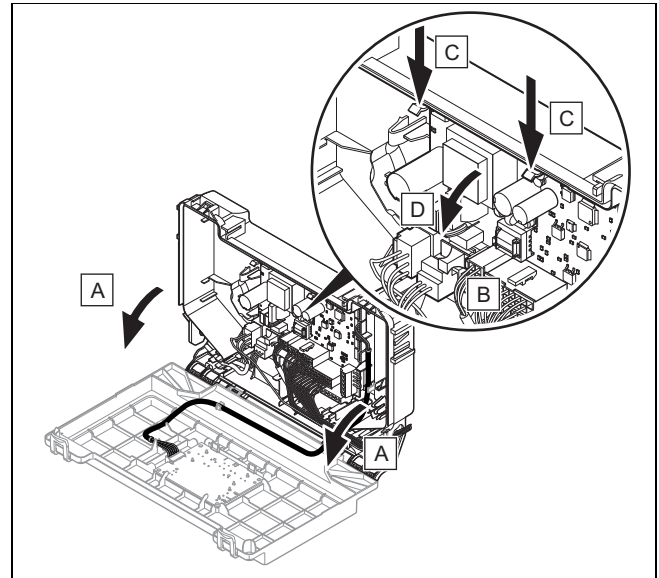

1. Prepare the repair work. (→ Page 41)
2. Open the electronics box. (→ Page 24)
3. Pull all of the plugs out from the PCB.
4. Undo the clips on the PCB.
5. Remove the PCB.
6. Install the new PCB in such a way that it clicks into the groove at the bottom and into the clip at the top.
7. Plug in the PCB plugs.
8. Close the electronics box.
9. Complete the repair work. (→ Page 44)

13.7.9 Replacing the PCB for the user interface

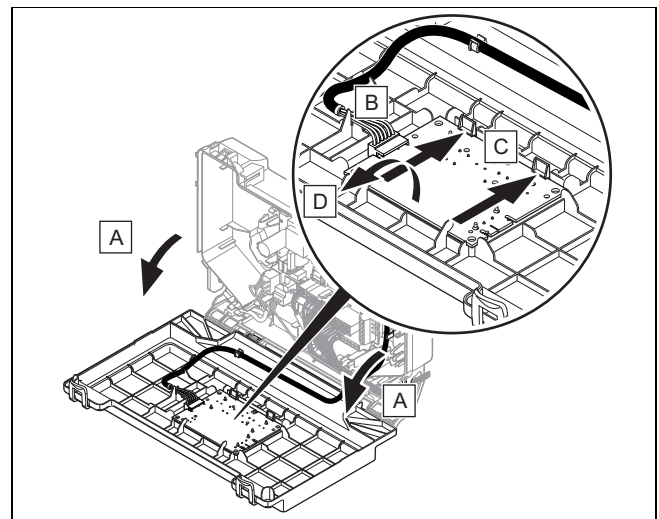

1. Prepare the repair work. (→ Page 41)
2. Open the electronics box. (→ Page 24)
3. Pull the plug out of the PCB.
4. Undo the clips on the PCB.
5. Remove the PCB.
6. Install the new PCB in such a way that it clicks into the groove at the bottom and into the clip at the top.
7. Plug in the PCB plug.
8. Close the electronics box.
9. Complete the repair work. (→ Page 44)

13.7.10 Replacing the power supply cable



Note

The cable must be replaced by the manufacturer, its customer service or suitably qualified persons in order to avoid danger.

- ▶ If the power supply cable is damaged, replace it in accordance with the recommendations for the power supply connection. (→ Page 24)
 - Cross-section of the power supply cable: 3 G 0,75mm²

13.8 Completing repair work

1. Establish the power supply.
2. Switch the product back on if this has not yet been done. (→ Page 30)
3. Install the front casing.
4. Open all service valves and the gas stopcock.

14 Decommissioning

14.1 Permanently decommissioning the product

- ▶ Press the on/off button.
 - ◀ The display goes out.
- ▶ Disconnect the product from the power grid.
- ▶ Close the gas stopcock.
- ▶ Close the cold-water isolation valve.
- ▶ Drain the product. (→ Page 40)

15 Recycling and disposal

Disposing of the packaging

- ▶ Dispose of the packaging correctly.
- ▶ Observe all relevant regulations.
- ▶ For detailed information refer to www.vaillant.co.uk.

Appendix

A Inspection and maintenance work

The table below lists the manufacturer requirements with respect to minimum inspection and maintenance intervals. If national regulations and directives require shorter inspection and maintenance intervals, you should observe these instead of the intervals listed. Each time inspection and maintenance work is carried out, carry out the required preparatory and completion work.

#	Maintenance work	Interval	
1	Record all of the analysis results in the Benchmark Checklist in these instructions	Annually	
2	Ask the end user whether any significant problems occur when operating the product	Annually	
3	Use the diagnostics system to check the product's fault history	Annually	
4	Visually inspect whether the air/flue pipe and its opening have been installed correctly in accordance with the set-up instructions	Annually	
5	Check that the unit has been installed correctly and the connections have been secured	Annually	
6	Check all of the connections for tightness	Annually	
7	Check that the condensate pipe is in good condition, that it is leak-tight and that the drain is correct	Annually	
8	Check whether all of the externally routed condensate pipes are dimensioned correctly and have been insulated sufficiently (frost protection)	Annually	
9	Check the general condition of the product and, if required, eliminate any faults that are found	Annually	
10	Visually check the heat cell to ascertain its condition and detect any corrosion, rust or damage, and carry out maintenance work, if required	Annually	
11	Check whether the gas flow rate corresponds with the specifications on the data plate and lies within the tolerances specified in these instructions	Annually	
12	If the gas flow rate lies outside of the tolerances specified in these instructions, eliminate the fault in accordance with the regulations and the current technology	Annually	
13	Carry out the combustion analysis: Measure the CO content, CO ₂ content and the CO/CO ₂ ratio. For products with a rear air/flue connection: The combustion analysis can only be carried out when the unit casing has been removed; it is not necessary to test these products for flue gas recirculation	Annually	
14	Check the product's recirculation at the supply air test point on the air/flue pipe. If required, inspect the entire air/flue system and, if necessary, correct the fault	Annually	
15	Disconnect the product from the electrical installation	Annually	
16	Check and, if required, correct the electrical installation	Annually	
17	Close the installation's gas stopcock and, if required, service valves	Annually	
18	Checking the admission pressure of the expansion vessel	at regular intervals	40
19	Checking the insulating mats in the combustion area and replacing damaged insulating mats	at regular intervals	
20	Cleaning the heat exchanger	at regular intervals	38
21	Checking the burner	at regular intervals	38
22	Cleaning the condensate siphon	Annually	39
23	Cleaning the strainer in the cold water inlet	at regular intervals	39
24	Check the impeller sensor for dirt/damage	at regular intervals	
25	If the water volume is insufficient (domestic hot water) or the outlet temperature is insufficient, check the secondary heat exchanger	at regular intervals	
26	Opening the service valves	Annually	
27	Check the quality of the heating water: Clarity (clouding), correct inhibitor and pH value	Annually	
28	Filling and purging the heating installation	at regular intervals	30
29	Starting a test operation after maintenance work	Annually	
30	Visually check the ignition and burner behaviour	Annually	
31	Measure the CO content, CO ₂ content and the CO/CO ₂ ratio again	Annually	

#	Maintenance work	Interval	
32	Checking leak-tightness	Annually	
33	Completing inspection and maintenance work	Annually	40

B Check programmes – Overview

Display	Meaning
P.00	Purging the domestic hot water and heating circuit: The function is activated in the small domestic hot water circuit for three minutes and then in the heating circuit for one minute. The pump runs and stops at regular intervals. If required, this function can be manually switched off.
P.01	The burner operates with an adjustable heat input in heating or domestic hot water mode: The product operates after ignition with the heat input set between "0" (0% = Pmin) and "100" (100% = Pmax). The function is active for 15 minutes.
P.02	The burner operates at ignition load in heating or domestic hot water mode: After ignition, the product works at ignition load. The function is active for 15 minutes.
P.06	Filling the product: The prioritising diverter valve is moved to the mid-position. The burner and pump switch off (to fill or drain the product).
Automatic air vent function	Purging the product: If the pressure is lower than 0.03 MPa (0.3 bar) for longer than 15 seconds and then is above 0.07 MPa (0.7 bar), the automatic purging function is activated. The function is activated in the small hot water circuit for four minutes and then in the heating circuit for six minutes. This function cannot be manually switched off.

C Overview of diagnostics codes



Note

Since the code table is used for various products, some codes may not be visible for the product in question.

Dia- gnostics code	Parameter	Values		Unit	Increment, select, explanation	Factory set- ting	Own setting
		Min.	Max.				
d.00	Maximum heating output is fixed or adjusts automatically	–	–	kW	The maximum heating output varies depending on the product. → Section "Technical data" Automatic: Unit automatically adjusts the maximum output to the current system demand	→ Section "Technical data"	Adjustable
d.01	Pump overrun time in heating mode	1	60	min	1	5	Adjustable
d.02	Maximum burner anti-cycling time in heating mode	2	60	min	1	20	Adjustable
d.04	Water temperature in the cylinder	Current value		°C	Applies to: Product with heating mode only, connected to domestic hot water cylinder with temperature sensor	–	Not adjustable
d.05	Determined target heating flow temperature	Current value		°C	–	–	Not adjustable
d.06	Target domestic hot water temperature	Current value		°C	Applies to: Combi boiler	–	Not adjustable
d.07	Target temperature for the domestic hot water cylinder	Current value		°C	Applies to: Product with heating mode only, connected to domestic hot water cylinder with temperature sensor	–	Not adjustable

Dia- gnostics code	Parameter	Values		Unit	Increment, select, explanation	Factory set- ting	Own setting
		Min.	Max.				
d.08	Status of the 230 V room thermostat (ON/OFF)	Current value		–	0 = Room thermostat open (no heat requirement) 1 = Room thermostat closed (heat requirement)	–	Not adjustable
d.09	Target heating flow temperature that is set on the eBUS room thermostat	Current value		°C	–	–	Not adjustable
d.10	Status of the internal pump in the heating circuit	Current value		–	off / on	–	Not adjustable
d.11	Status of the heating circuit's shunt pump	Current value		–	Applies to: Installed heating circuit shunt pump (optional) off / on	–	Not adjustable
d.13	Status of the domestic hot water circuit's circulation pump	Current value		–	Applies to: Installed domestic hot water circuit circulation pump (optional) off / on	–	Not adjustable
d.14	Operating mode of the modulating pump	0	5	–	0 = Speed-regulated (automatic pump operation in levels 1 to 5) 1 = PWM = 65 % 2 = PWM = 73 % 3 = PWM = 80 % 4 = PWM = 88 % 5 = PWM = 95 % 1; 2; 3; 4; 5 = Fixed rotational speeds → Section "Setting the pump output"	0	Adjustable
d.15	Pump speed	Current value		%	–	–	Not adjustable
d.16	Status of the 24 V room thermostat	Current value		–	off = Heating off on = Heating activated or eBUS controller used	–	Not adjustable
d.17	Heating control	–	–	–	off = Flow temperature on = Return temperature (adjustment for underfloor heating. If you have activated the return temperature control, the automatic heating output determination function is not active.)	0	Adjustable
d.18	Pump overrun operating mode	1	3	–	1 = Comfort (continuously operating pump) 3 = Eco (pump runs intermittently)	3	Adjustable
d.20	Maximum target domestic hot water temperature	50	60	°C	1	60	Adjustable
d.21	Status of the warm start for domestic hot water	Current value		–	off = Function deactivated on = Function activated and available	–	Not adjustable
d.22	Status of the DHW demand	Current value		–	off = No current requirement on = Current requirement	–	Not adjustable
d.23	Status of the heat demand	Current value		–	off = Heating off (Summer mode) on = Heating on	–	Not adjustable
d.25	Status of the requirement to reheat the cylinder or for the domestic hot water warm start from the eBUS thermostat	Current value		–	off = Function deactivated on = Function activated	–	Not adjustable

Dia- gnostics code	Parameter	Values		Unit	Increment, select, explanation	Factory set- ting	Own setting
		Min.	Max.				
d.27	Function of relay 1 (multi-functional module)	1	10	–	1 = Circulation pump 2 = External pump 3 = Cylinder charging pump 4 = Extraction hood 5 = External solenoid valve 6 = External fault message 7 = Solar pump (omitted) 8 = eBUS remote control 9 = Anti-legionella pump 10 = Solar valve	1	Adjustable
d.28	Function of relay 2 (multi-functional module)	1	10	–	1 = Circulation pump 2 = External pump 3 = Cylinder charging pump 4 = Extraction hood 5 = External solenoid valve 6 = External fault message 7 = Solar pump (omitted) 8 = eBUS remote control 9 = Anti-legionella pump 10 = Solar valve	2	Adjustable
d.33	Fan speed target value	Current value		rpm	Fan speed = Display value x 100	–	Not adjustable
d.34	Value for the fan speed	Current value		rpm	Fan speed = Display value x 100	–	Not adjustable
d.35	Position of the prioritising diverter valve	Current value		–	0 = Heating 40 = Mid-position (frost protection or filling) 100 = Domestic hot water	–	Not adjustable
d.36	Value for the domestic hot water flow rate	Current value		l/min	Applies to: Combi boiler	–	Not adjustable
d.39	Water temperature in the solar circuit	Current value		°C	Applies to: Installed solar set (optional)	–	Not adjustable
d.40	Heating flow temperature	Current value		°C	–	–	Not adjustable
d.41	Heating return temperat- ure	Current value		°C	–	–	Not adjustable
d.43	Heat curve	0.2	4	–	0.1	1.2	Adjustable
d.45	Base point of the heat curve	15	30	–	1	20	Adjustable
d.47	Outdoor temperature	Current value		°C	–	–	Not adjustable
d.50	Correction of the min- imum fan speed	300	1500	rpm	1 Fan speed = Display value x 10	600	Adjustable
d.51	Correction of the max- imum fan speed	-1500	-500	rpm	1 Fan speed = Display value x 10	-1000	Adjustable
d.58	Solar circuit reheating	0	3	–	Applies to: Installed solar set (optional) 0 = Product's anti-legionella func- tion deactivated 3 = Domestic hot water activated (min. target value 60 °C)	0	Adjustable
d.60	Number of blocks by the temperature cut-out (limit temperature)	Current value		–	–	–	Not adjustable
d.61	Number of unsuccessful ignitions	Current value		–	–	–	Not adjustable
d.64	Average burner ignition time	Current value		s	–	–	Not adjustable
d.65	Maximum burner ignition time	Current value		s	–	–	Not adjustable

Dia- gnostics code	Parameter	Values		Unit	Increment, select, explanation	Factory set- ting	Own setting
		Min.	Max.				
d.66	Activation of the warm start function for domestic hot water	–	–	–	off = Function deactivated on = Function activated	1	Adjustable
d.67	Remaining burner anti-cycling time (setting under d.02)	Current value		min	–	–	Not adjustable
d.68	Number of unsuccessful ignitions at 1st attempt	Current value		–	–	–	Not adjustable
d.69	Number of unsuccessful ignitions at 2nd attempt	Current value		–	–	–	Not adjustable
d.71	Maximum target heating flow temperature	30	80	°C	1	→ Section "Technical data"	Adjustable
d.73	Correction of the domestic hot water warm start temperature	-15	5	K	Applies to: Combi boiler 1	0	Adjustable
d.75	Maximum cylinder post-heating time	20	90	min	Applies to: Product with heating mode only 1	45	Adjustable
d.77	Max. cylinder post-heating	–	–	kW	Applies to: Product with heating mode only 1 → Section "Technical data"	–	Adjustable
d.80	Running time in heating mode	Current value		h	Running time = Display value x 100	–	Not adjustable
d.81	Running time in domestic hot water mode	Current value		h	Running time = Display value x 100	–	Not adjustable
d.82	Number of burner ignitions in heating mode	Current value		–	Number of ignitions = Display value x 100	–	Not adjustable
d.83	Number of burner ignitions in domestic hot water mode	Current value		–	Number of ignitions = Display value x 100	–	Not adjustable
d.84	Maintenance in	0	3000	h	Number of hours = Display value x 10	---	Not adjustable
d.85	Increase in the min. output (heating and domestic hot water mode)	–	–	kW	1	–	Adjustable
d.88	Flow rate limit value for ignition in domestic hot water mode	0	1	–	Applies to: Combi boiler 0 = 1.5 l/min (no delay) 1 = 3.7 l/min (2 s delay)	0	Adjustable
d.90	Status of the eBUS room thermostat	Current value		–	off = Not connected on = Connected	–	Not adjustable
d.91	Status DCF77	Current value		–	–	–	Not adjustable
d.93	Setting the product code	0	99	–	1 The Device Specific Number (DSN) can be found on the data plate.	–	Adjustable
d.94	Delete fault list	0	1	–	0 = No 1 = Yes	–	Adjustable
d.95	Software versions	–	–	–	1 = Main PCB 2 = Interface PCB	–	Not adjustable
d.96	Factory reset	0	1	–	0 = No 1 = Yes	–	Adjustable

D Status codes – Overview



Note

Since the code table is used for various products, some codes may not be visible for the product in question.

Status code	Meaning
Displays in heating mode	
S.00	Heating mode: No requirement
S.01	Heating mode: Fan prerun
S.02	Heating mode: Pump prerun
S.03	Heating mode: Burner ignition
S.04	Heating mode: Burner on
S.05	Heating mode: Pump/fan overrun
S.06	Heating mode: Fan overrun
S.07	Heating mode: Pump overrun
S.08	Heating mode: Temporary shutdown after heating procedure
Displays in domestic hot water mode	
S.10	Domestic hot water mode: Requirement
S.11	Domestic hot water mode: Fan prerun
S.13	Domestic hot water mode: Burner ignition
S.14	DHW mode: Burner on
S.15	DHW mode: Pump/fan overrun
S.16	DHW mode: Fan overrun
S.17	DHW mode: Pump overrun
Display in comfort mode with warm start or domestic hot water mode with cylinder	
S.20	Domestic hot water mode: Requirement
S.21	Domestic hot water mode: Fan prerun
S.22	Domestic hot water mode: Pump prerun
S.23	Domestic hot water mode: Burner ignition
S.24	DHW mode: Burner on
S.25	DHW mode: Pump/fan overrun
S.26	DHW mode: Fan overrun
S.27	DHW mode: Pump overrun
S.28	Domestic hot water mode: Temporary shutdown of the burner
Other displays	
S.30	Room thermostat is blocking heating mode.
S.31	No heating demand: Summer mode, eBUS control, waiting period
S.32	Fan waiting time: Fan speed outside of the tolerance values
S.34	Frost protection active
S.39	Underfloor heating contact open
S.42	Accessory fault: Flue non-return flap closed or condensate pump fault
S.53	Product in waiting period / operating block function due to water deficiency (flow/return spread too large)
S.54	Waiting period: Water deficiency in the circuit (flow/return spread too large)
S.88	Product purging active
S.91	Maintenance: Operating display demo mode
S.96	Automatic test programme: Flow and return temperature sensors, heating and domestic hot water demand blocked or product fault.
S.97	The self-test for the water pressure sensor is activated.
S.98	Automatic test programme: Return temperature sensor, heating and domestic hot water demand blocked.
S.108	Purging the combustion chamber, fan in operation
S.109	Product's standby mode activated

E Overview of fault codes



Note

Since the code table is used for various products, some codes may not be visible for the product in question.

If faults occur, some of them can be reset. To do so, press and hold the  button for three seconds.

Fault code	Meaning	Possible cause
F.00	Fault: Flow temperature sensor	NTC plug not plugged in or has come loose, multiple plug on the PCB not plugged in correctly, interruption in cable harness, NTC sensor defective
F.01	Fault: Return temperature sensor	NTC plug not plugged in or has come loose, multiple plug on the PCB not plugged in correctly, interruption in cable harness, NTC sensor defective
F.10	Short circuit: Flow temperature sensor	NTC sensor defective, short circuit in the cable harness, cable/housing
F.11	Short circuit: Return temperature sensor	NTC sensor defective, short circuit in the cable harness, cable/housing
F.13	Short circuit: Temperature sensor for the domestic hot water cylinder	Applies to: Product with heating mode only NTC sensor defective, short circuit in the cable harness, cable/housing
F.20	Safety shutdown: Overheating temperature reached	Overheating temperature reached; check whether water is available and whether the flow rate is sufficient. Incorrect earth connection between cable harness and product, flow or return NTC defective (loose connection), stray spark via ignition cable, ignition plug or ignition electrode
F.22 / 0,0 bar	Safety shutdown: Water deficiency in the boiler	No water or insufficient water in the product, water pressure sensor defective, cable to water pressure sensor loose/not connected/defective
F.23	Safety shutdown: Temperature spread too great (NTC1/NTC2)	Pump blocked, insufficient pump output, air in product, flow and return NTC sensors connected the wrong way round
F.24	Safety shutdown: Temperature rise too fast	Pump blocked, insufficient pump output, air in product, system pressure too low, non-return valve blocked/incorrectly installed
F.27	Safety shutdown: Fault in flame detection	Moisture on the electronics, electronics (flame monitor) defective, gas solenoid valve leaking
F.28	Fault: Ignition unsuccessful when starting up	Gas meter defective or gas pressure switch has triggered, air in gas, gas flow pressure too low, thermal cut-out has triggered, incorrect gas injector, incorrect spare gas valve assembly, fault on the gas valve assembly, multiple plug on PCB incorrectly plugged in, break in cable harness, ignition system (ignition transformer, ignition cable, ignition plug, ignition electrode) defective, ionisation flow interrupted (cable, electrode), incorrect earthing of product, electronics defective
F.29	Fault: Reignition following flame loss unsuccessful	Gas supply temporarily stopped, flue gas recirculation, incorrect earthing of product, ignition transformer has spark failure
F.32	Fan speed outside of the tolerance values	Plug on fan not correctly plugged in, multiple plug on PCB not correctly plugged in, break in cable harness, fan blocked, Hall sensor defective, electronics defective
F.46	Short circuit: Additional temperature sensor at the water inlet	Applies to: Installed solar set (optional) Sensor defective, short circuit in the cable harness, cable/housing
F.49	eBUS fault: Voltage too low	Short circuit on the eBUS, eBUS overload or two power supplies with different polarities on the eBUS (can only be found in the fault report)
F.61	Fault: Fuel valve actuation. The gas valve assembly cannot be actuated	Check: Cable harness, plug, gas valve assembly (coils), PCB.
F.62	Fault: Gas valve switch-off control	Delayed switch-off of gas valve assembly, delayed extinguishing of flame signal, gas valve assembly leaking, electronics defective
F.63	Fault: EEPROM	Electronics defective
F.64	Fault: Electronics / sensor / analogue-to-digital converter	Flow or return NTC short circuited, electronics defective
F.65	Fault: Electronics temperature too high	Electronics overheating due to external influences, electronics defective
F.67	Value sent back by ASIC is incorrect (flame signal)	Implausible flame signal, electronics defective
F.68	Fault: Unstable flame (analogue input)	Air in gas, gas flow pressure too low, incorrect air ratio, incorrect gas injector, ionisation flow interruption (cable, electrode) Electronics defective
F.70	Invalid product code (DSN)	Replace the screen and PCB at the same time without reconfiguring the product's Device Specific Number
F.71	Fault: Flow/return temperature sensor	Flow temperature sensor specifies the constant value: Flow temperature sensor incorrectly attached to the flow pipe, flow temperature sensor defective

Fault code	Meaning	Possible cause
F.72	Fault: Deviation in the water pressure sensor/return temperature sensor	Flow/return NTC temperature difference too great → flow and/or return temperature sensor defective
F.73	Fault: Water pressure sensor short-circuited	Short circuit of water pressure sensor, short to earth in supply pipe to water pressure sensor or water pressure sensor defective
F.74	Fault: Water pressure sensor not connected	Interruption in water pressure sensor, interruption in supply pipe to water pressure sensor or water pressure sensor defective
F.75	Fault: Pump/water deficiency	Insufficient pressure jump detected when starting the pump Check: Water pressure sensor, heating pump (blockage), heating circuit (air, sufficient water volume), adjustable bypass, external expansion vessel (must be connected at the return). Activate check programme P.0.
F.77	Fault: Condensate or smoke	Applies to: Installed condensate pump or flue non-return flap (optional) Check the defective condensate pump or flue non-return flap
F.83	Fault: Dry fire	When the burner starts, the temperature change recorded by the flow or return temperature sensor is non-existent or too small: Insufficient water in the product, flow or return temperature sensor incorrectly attached to the pipe
F.84	Fault: Flow/return temperature sensor	Values not consistent, difference between flow and return < -6 K Flow and return temperature sensors signalling implausible values: Flow and return temperature sensors have been inverted, flow and return temperature sensors have not been correctly installed
F.85	Fault: Temperature sensor	The flow and/or return temperature sensors have been installed on the same pipe/incorrect pipe Temperature sensor not connected or is connected incorrectly
F.87	Fault: Ignition transformer cable	Ignition transformer cable harness not connected to the main PCB or it is connected incorrectly, short circuit in the cable harness or damaged ignition transformer
F.88	Fault: Gas valve assembly	Gas valve assembly not connected or it is connected incorrectly, interruption in the cable harness
F.89	Fault: Pump	Pump not connected or it is connected incorrectly, incorrect pump connected, short circuit in the cable harness
F.97	Fault: Main PCB self-test failed	Main PCB defective
Err	Fault: Interface communication	Interface PCB not connected or connected incorrectly, short circuit in the cable harness

F Wiring diagrams

F.1 Wiring diagram

Validity: VUW 246/7-2 (H-GB) AND VUW 286/7-2 (H-GB)

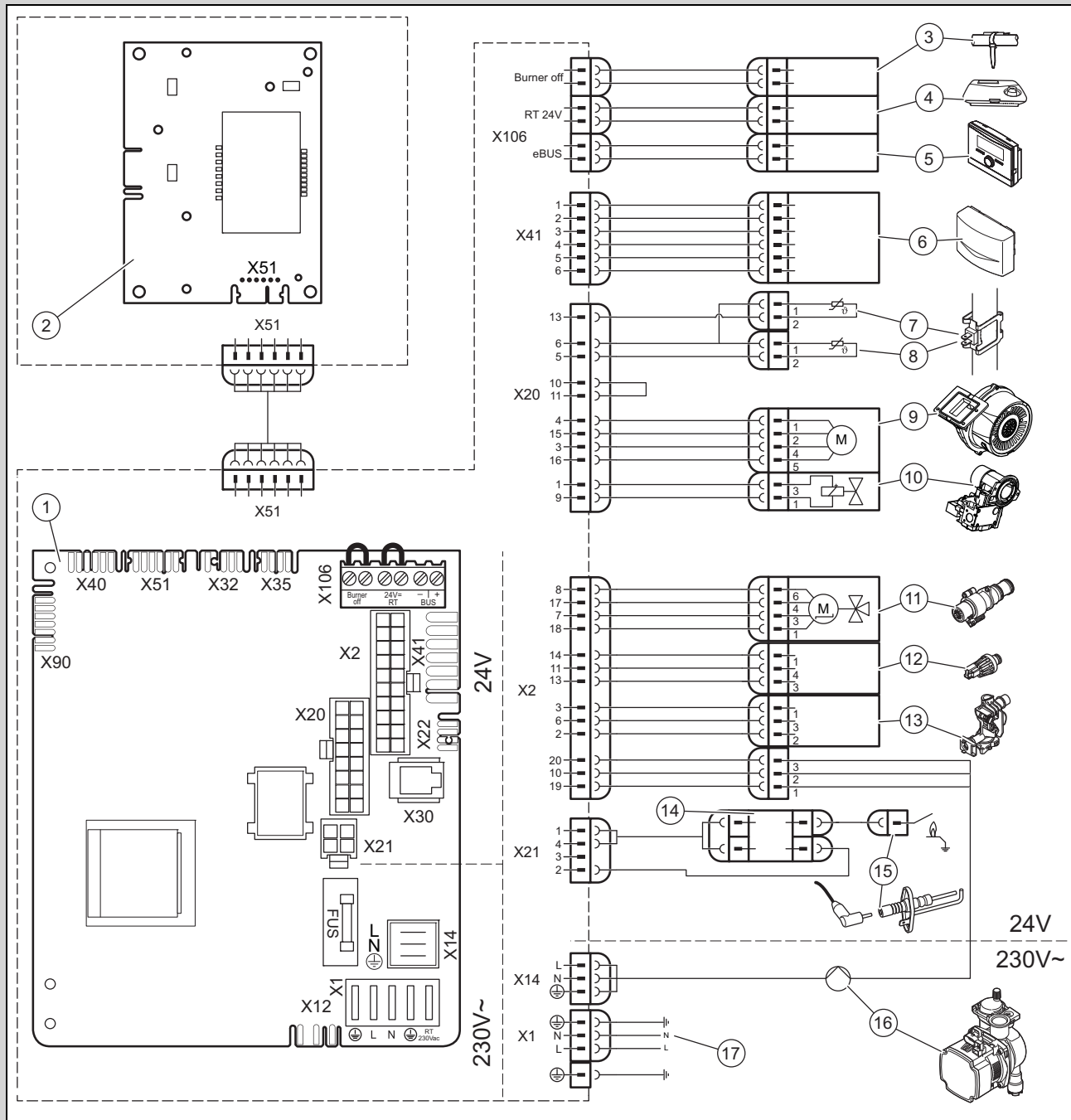

- | | | | |
|---|--|----|-----------------------------------|
| 1 | Main PCB | 10 | Gas valve assembly |
| 2 | Interface PCB | 11 | Prioritising diverter valve |
| 3 | Safety thermostat for underfloor heating | 12 | Pressure sensor |
| 4 | 24 V DC room thermostat | 13 | Volume flow sensor |
| 5 | Bus connection (digital room thermostat/control) | 14 | External ignition device |
| 6 | Outdoor temperature sensor, wired | 15 | Ionisation and ignition electrode |
| 7 | Temperature sensor in the heating return | 16 | Heating pump |
| 8 | Temperature sensor in the heating flow | 17 | Main power supply |
| 9 | Fan | | |

F.2 Wiring diagram

Validity: VUW 346/7-2 (H-GB)

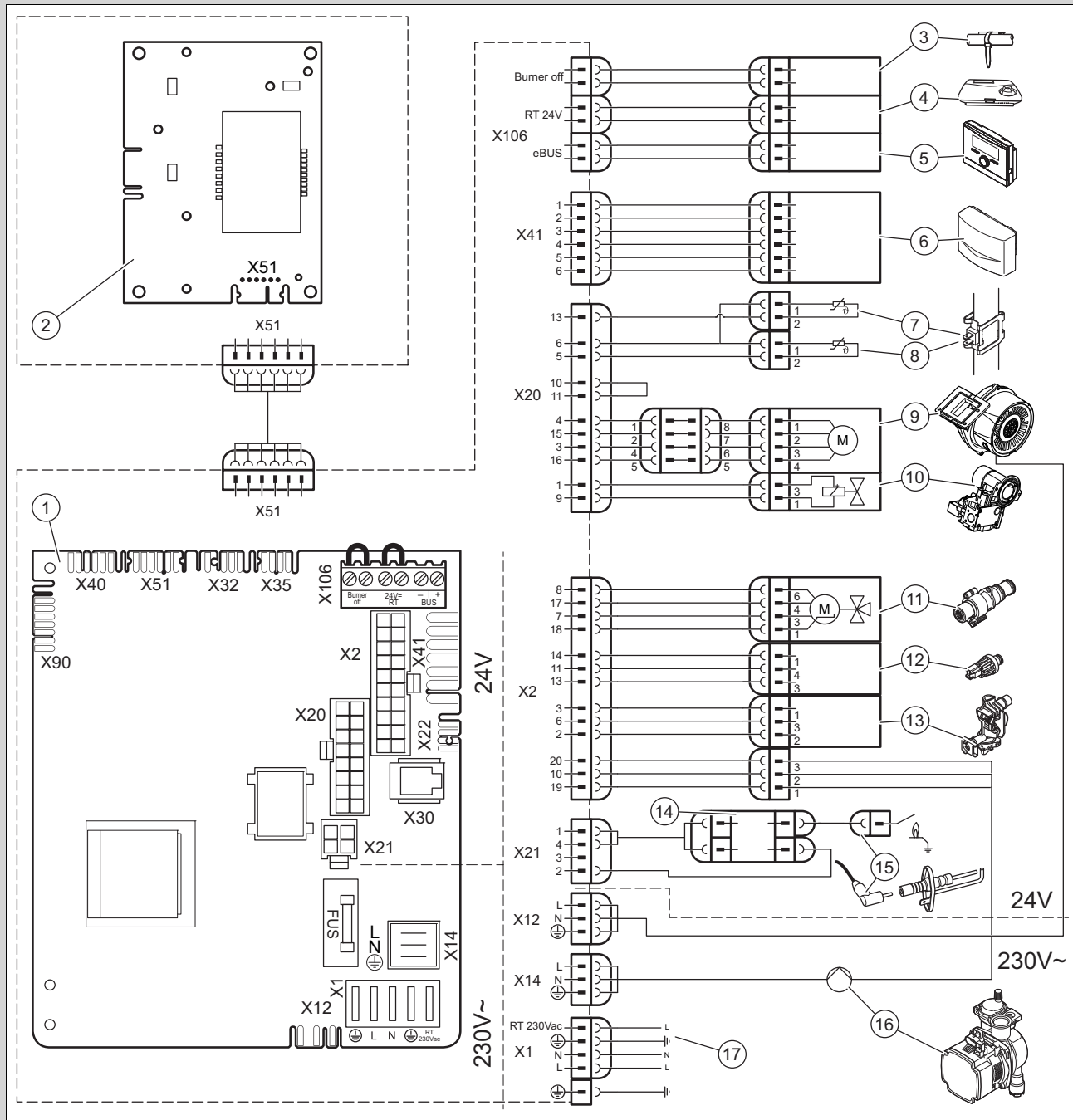

- | | | | |
|---|---|----|-----------------------------------|
| 1 | Main PCB | 10 | Gas valve |
| 2 | Interface PCB | 11 | Diverter valve |
| 3 | Safety thermostat for underfloor heating | 12 | Pressure sensor |
| 4 | 24 V DC room thermostat | 13 | Mass flow- |
| 5 | Bus connection (digital room thermostat/controller) | 14 | External ignition device |
| 6 | Outside temperature sensor, wired | 15 | Ionisation and ignition electrode |
| 7 | Temperature sensor in the heating return | 16 | Heating pump |
| 8 | Temperature sensor in the heating flow | 17 | Main power supply |
| 9 | Fan | | |

Benchmark Commissioning & Warranty Validation Service Record

It is a requirement that the boiler is installed and commissioned to the manufacturers' instructions and the data fields on the commissioning checklist completed in full.

To instigate the boiler warranty the boiler needs to be registered with the manufacturer within one month of the installation. The warranty rests with the end-user (consumer), and they should be made aware it is ultimately their responsibility to register with the manufacturer, within the allotted time period.

It is essential that the boiler is serviced in line with the manufacturers' recommendations, at least annually. This must be carried out by a competent Gas Safe registered engineer. The service details should be recorded on the Benchmark Service and Interim Boiler Work Record and left with the householder. Failure to comply with the manufacturers' servicing instructions and requirements will invalidate the warranty.



www.hhic.co.uk

This Commissioning Checklist is to be completed in full by the competent person who commissioned the boiler as a means of demonstrating compliance with the appropriate Building Regulations and then handed to the customer to keep for future reference.

Failure to install and commission according to the manufacturers' instructions and complete this Benchmark Commissioning Checklist will invalidate the warranty. This does not affect the customer's statutory rights.

* All installations in England and Wales must be notified to Local Authority Building Control (LABC) either directly or through a Competent Persons Scheme. A Building Regulations Compliance Certificate will then be issued to the customer.

© Heating and Hotwater Industry Council (HHIC)



www.centralheating.co.uk

GAS BOILER SYSTEM COMMISSIONING CHECKLIST & WARRANTY VALIDATION RECORD

Address:													
Boiler make and model:													
Boiler serial number:													
Commissioned by (PRINT NAME):						Gas Safe registration number:							
Company name:						Telephone number:							
Company email:						Company address:							
										Commissioning date:			
Heating and hot water system complies with the appropriate Building Regulations?											Yes		
Optional: Building Regulations Notification Number (if applicable):													
Time, temperature control and boiler interlock provided for central heating and hot water											Yes		
Boiler Plus requirements (tick the appropriate box(s))													
Boiler Plus option chosen for combination boiler in ENGLAND						Weather compensation			Smart thermostat with automation and optimisation				
						Load compensation			Flue Gas Heat Recovery				
Time and temperature control to hot water			Cylinder thermostat and programmer/timer			Combination boiler							
Zone valves		pre-existing		Fitted		Not required							
Thermostatic radiator valves		pre-existing		Fitted		Not required							
Automatic bypass to system		pre-existing		Fitted		Not required							
Underfloor heating		pre-existing		Fitted		Not required							
Water quality													
The system has been flushed, cleaned and a suitable inhibitor applied upon final fill, in accordance with BS7593 and boiler manufacturers' instructions											Yes		
What system cleaner was used?						Brand:			Product:				
What inhibitor was used?						Brand:			Product:				
Primary water system filter		pre-existing		Fitted		Not required							
CENTRAL HEATING MODE measure and record (as appropriate)													
Gas rate (for combination boilers complete DHW mode gas rate)						m ³ /hr			or			ft ³ /hr	
Central heating output left at factory settings?						Yes			No				
If no, what is the maximum central heating output selected? kW													
Dynamic gas inlet pressure mbar													
Central heating flow temperature °C													
Central heating return temperature °C													
System correctly balanced/rebalanced?											Yes		
COMBINATION BOILERS ONLY													
Is the installation in a hard water area (above 200ppm)?						Yes			No				
Water scale reducer/softener		pre-existing		Fitted		Not required							
What type of scale reducer/softener has been fitted?						Brand:			Product:				
Water meter fitted?						Yes			No				
If yes- DHW expansion vessel		pre-existing		Fitted		Not required							
Pressure reducing valve		pre-existing		Fitted		Not required							
DOMESTIC HOT WATER MODE Measure and record													
Gas rate						m ³ /hr			or			ft ³ /hr	
Dynamic gas inlet pressure at maximum rate mbar													
Cold water inlet temperature °C													
Hot water has been checked at all outlets						Yes			Temperature			°C	
CONDENSATE DISPOSAL													
The condensate drain has been installed in accordance with the manufacturers' instructions and/or BS5546/BS6798											Yes		
Point of termination						Internal			External (only where internal termination impractical)				
Method of disposal						Gravity			Pumped				
ALL INSTALLATIONS													
Record the following		At max rate:		CO ppm		CO ₂ %		CO/CO ₂		Ratio			
		At min rate (where possible)		CO ppm		CO ₂ %		CO/CO ₂		Ratio			
Where possible, has a flue integrity check been undertaken in accordance with manufacturers' instructions, and readings are correct?											Yes		
The operation of the boiler and system controls have been demonstrated to and understood by the customer											Yes		
The manufacturers' literature, including Benchmark Checklist and Service Record, has been explained and left with the customer											Yes		
Commissioning Engineer's signature													
Customer's signature (To confirm satisfactory demonstration and receipt of manufacturers' literature)													

* All installations in England and Wales must be notified to Local Authority Building Control (LABC) either directly or through a Competent Persons Scheme. A Building Regulations Compliance Certificate will then be issued to the customer.

© Heating and Hotwater Industry Council (HHIC)



www.centralheating.co.uk

SERVICE & INTERIM BOILER WORK RECORD

It is recommended that your boiler and heating system are regularly serviced and maintained, in line with manufacturers' instructions, and that the appropriate service / interim work record is completed.

Service provider

When completing a service record (as below), please ensure you have carried out the service as described in the manufacturers' instructions. Always use the manufacturers' specified spare parts.

SERVICE/INTERIM WORK ON BOILER <small>delete as appropriate</small>					Date:	
Engineer name:		Company name:				
Telephone N°:		Gas Safe registration N°:				
Max rate	CO	ppm	CO ₂	%	CO/CO ₂	
Min rate	CO	ppm	CO ₂	%	CO/CO ₂	
Where possible, has a flue integrity check been undertaken in accordance with manufacturers' instructions, and readings are correct?*					yes	
Gas rate:	m ³ /h	OR	ft ³ /h			
Were parts fitted? <small>delete as appropriate</small>		Yes	No			
Parts fitted:						
System inhibitor concentration has been checked and appropriate action taken, in accordance with BS 7593 and boiler manufacturers' instructions. *					yes	n/a
Comments:						
Signature:						

*A System inhibitor efficacy test is required on every annual service in accordance with the manufacturers' instructions and BS 7593. It is only acceptable to not have undertaken this if the service engineers attendance visit was in between annual services to attend a non-water facing component.

SERVICE/INTERIM WORK ON BOILER <small>delete as appropriate</small>					Date:	
Engineer name:		Company name:				
Telephone N°:		Gas Safe registration N°:				
Max rate	CO	ppm	CO ₂	%	CO/CO ₂	
Min rate	CO	ppm	CO ₂	%	CO/CO ₂	
Where possible, has a flue integrity check been undertaken in accordance with manufacturers' instructions, and readings are correct?*					yes	
Gas rate:	m ³ /h	OR	ft ³ /h			
Were parts fitted? <small>delete as appropriate</small>		Yes	No			
Parts fitted:						
System inhibitor concentration has been checked and appropriate action taken, in accordance with BS 7593 and boiler manufacturers' instructions. *					yes	n/a
Comments:						
Signature:						

*A System inhibitor efficacy test is required on every annual service in accordance with the manufacturers' instructions and BS 7593. It is only acceptable to not have undertaken this if the service engineers attendance visit was in between annual services to attend a non-water facing component.

SERVICE/INTERIM WORK ON BOILER <small>delete as appropriate</small>					Date:	
Engineer name:		Company name:				
Telephone N°:		Gas Safe registration N°:				
Max rate	CO	ppm	CO ₂	%	CO/CO ₂	
Min rate	CO	ppm	CO ₂	%	CO/CO ₂	
Where possible, has a flue integrity check been undertaken in accordance with manufacturers' instructions, and readings are correct?*					yes	
Gas rate:	m ³ /h	OR	ft ³ /h			
Were parts fitted? <small>delete as appropriate</small>		Yes	No			
Parts fitted:						
System inhibitor concentration has been checked and appropriate action taken, in accordance with BS 7593 and boiler manufacturers' instructions. *					yes	n/a
Comments:						
Signature:						

*A System inhibitor efficacy test is required on every annual service in accordance with the manufacturers' instructions and BS 7593. It is only acceptable to not have undertaken this if the service engineers attendance visit was in between annual services to attend a non-water facing component.

SERVICE/INTERIM WORK ON BOILER <small>delete as appropriate</small>					Date:	
Engineer name:		Company name:				
Telephone N°:		Gas Safe registration N°:				
Max rate	CO	ppm	CO ₂	%	CO/CO ₂	
Min rate	CO	ppm	CO ₂	%	CO/CO ₂	
Where possible, has a flue integrity check been undertaken in accordance with manufacturers' instructions, and readings are correct?*					yes	
Gas rate:	m ³ /h	OR	ft ³ /h			
Were parts fitted? <small>delete as appropriate</small>		Yes	No			
Parts fitted:						
System inhibitor concentration has been checked and appropriate action taken, in accordance with BS 7593 and boiler manufacturers' instructions. *					yes	n/a
Comments:						
Signature:						

*A System inhibitor efficacy test is required on every annual service in accordance with the manufacturers' instructions and BS 7593. It is only acceptable to not have undertaken this if the service engineers attendance visit was in between annual services to attend a non-water facing component.

SERVICE/INTERIM WORK ON BOILER <small>delete as appropriate</small>					Date:	
Engineer name:		Company name:				
Telephone N°:		Gas Safe registration N°:				
Max rate	CO	ppm	CO ₂	%	CO/CO ₂	
Min rate	CO	ppm	CO ₂	%	CO/CO ₂	
Where possible, has a flue integrity check been undertaken in accordance with manufacturers' instructions, and readings are correct?*					yes	
Gas rate:	m ³ /h	OR	ft ³ /h			
Were parts fitted? <small>delete as appropriate</small>		Yes	No			
Parts fitted:						
System inhibitor concentration has been checked and appropriate action taken, in accordance with BS 7593 and boiler manufacturers' instructions. *					yes	n/a
Comments:						
Signature:						

*A System inhibitor efficacy test is required on every annual service in accordance with the manufacturers' instructions and BS 7593. It is only acceptable to not have undertaken this if the service engineers attendance visit was in between annual services to attend a non-water facing component.

SERVICE/INTERIM WORK ON BOILER <small>delete as appropriate</small>					Date:	
Engineer name:		Company name:				
Telephone N°:		Gas Safe registration N°:				
Max rate	CO	ppm	CO ₂	%	CO/CO ₂	
Min rate	CO	ppm	CO ₂	%	CO/CO ₂	
Where possible, has a flue integrity check been undertaken in accordance with manufacturers' instructions, and readings are correct?*					yes	
Gas rate:	m ³ /h	OR	ft ³ /h			
Were parts fitted? <small>delete as appropriate</small>		Yes	No			
Parts fitted:						
System inhibitor concentration has been checked and appropriate action taken, in accordance with BS 7593 and boiler manufacturers' instructions. *					yes	n/a
Comments:						
Signature:						

*A System inhibitor efficacy test is required on every annual service in accordance with the manufacturers' instructions and BS 7593. It is only acceptable to not have undertaken this if the service engineers attendance visit was in between annual services to attend a non-water facing component.

* All installations in England and Wales must be notified to Local Authority Building Control (LABC) either directly or through a Competent Persons Scheme. A Building Regulations Compliance Certificate will then be issued to the customer.

© Heating and Hotwater Industry Council (HHIC)



www.centralheating.co.uk

SERVICE & INTERIM BOILER WORK RECORD

It is recommended that your boiler and heating system are regularly serviced and maintained, in line with manufacturers' instructions, and that the appropriate service / interim work record is completed.

Service provider

When completing a service record (as below), please ensure you have carried out the service as described in the manufacturers' instructions. Always use the manufacturers' specified spare parts.

SERVICE/INTERIM WORK ON BOILER <small>delete as appropriate</small>					Date:
Engineer name:		Company name:			
Telephone N°:		Gas Safe registration N°:			
Max rate	CO	ppm	CO ₂	%	CO/CO ₂
Min rate	CO	ppm	CO ₂	%	CO/CO ₂
Where possible, has a flue integrity check been undertaken in accordance with manufacturers' instructions, and readings are correct?*					yes
Gas rate:	m ³ /h	OR	ft ³ /h		
Were parts fitted? <small>delete as appropriate</small>		Yes	No		
Parts fitted:					
System inhibitor concentration has been checked and appropriate action taken, in accordance with BS 7593 and boiler manufacturers' instructions. *					yes n/a
Comments:					
Signature:					

*A System inhibitor efficacy test is required on every annual service in accordance with the manufacturers' instructions and BS 7593. It is only acceptable to not have undertaken this if the service engineers attendance visit was in between annual services to attend a non-water facing component.

SERVICE/INTERIM WORK ON BOILER <small>delete as appropriate</small>					Date:
Engineer name:		Company name:			
Telephone N°:		Gas Safe registration N°:			
Max rate	CO	ppm	CO ₂	%	CO/CO ₂
Min rate	CO	ppm	CO ₂	%	CO/CO ₂
Where possible, has a flue integrity check been undertaken in accordance with manufacturers' instructions, and readings are correct?*					yes
Gas rate:	m ³ /h	OR	ft ³ /h		
Were parts fitted? <small>delete as appropriate</small>		Yes	No		
Parts fitted:					
System inhibitor concentration has been checked and appropriate action taken, in accordance with BS 7593 and boiler manufacturers' instructions. *					yes n/a
Comments:					
Signature:					

*A System inhibitor efficacy test is required on every annual service in accordance with the manufacturers' instructions and BS 7593. It is only acceptable to not have undertaken this if the service engineers attendance visit was in between annual services to attend a non-water facing component.

SERVICE/INTERIM WORK ON BOILER <small>delete as appropriate</small>					Date:
Engineer name:		Company name:			
Telephone N°:		Gas Safe registration N°:			
Max rate	CO	ppm	CO ₂	%	CO/CO ₂
Min rate	CO	ppm	CO ₂	%	CO/CO ₂
Where possible, has a flue integrity check been undertaken in accordance with manufacturers' instructions, and readings are correct?*					yes
Gas rate:	m ³ /h	OR	ft ³ /h		
Were parts fitted? <small>delete as appropriate</small>		Yes	No		
Parts fitted:					
System inhibitor concentration has been checked and appropriate action taken, in accordance with BS 7593 and boiler manufacturers' instructions. *					yes n/a
Comments:					
Signature:					

*A System inhibitor efficacy test is required on every annual service in accordance with the manufacturers' instructions and BS 7593. It is only acceptable to not have undertaken this if the service engineers attendance visit was in between annual services to attend a non-water facing component.

SERVICE/INTERIM WORK ON BOILER <small>delete as appropriate</small>					Date:
Engineer name:		Company name:			
Telephone N°:		Gas Safe registration N°:			
Max rate	CO	ppm	CO ₂	%	CO/CO ₂
Min rate	CO	ppm	CO ₂	%	CO/CO ₂
Where possible, has a flue integrity check been undertaken in accordance with manufacturers' instructions, and readings are correct?*					yes
Gas rate:	m ³ /h	OR	ft ³ /h		
Were parts fitted? <small>delete as appropriate</small>		Yes	No		
Parts fitted:					
System inhibitor concentration has been checked and appropriate action taken, in accordance with BS 7593 and boiler manufacturers' instructions. *					yes n/a
Comments:					
Signature:					

*A System inhibitor efficacy test is required on every annual service in accordance with the manufacturers' instructions and BS 7593. It is only acceptable to not have undertaken this if the service engineers attendance visit was in between annual services to attend a non-water facing component.

SERVICE/INTERIM WORK ON BOILER <small>delete as appropriate</small>					Date:
Engineer name:		Company name:			
Telephone N°:		Gas Safe registration N°:			
Max rate	CO	ppm	CO ₂	%	CO/CO ₂
Min rate	CO	ppm	CO ₂	%	CO/CO ₂
Where possible, has a flue integrity check been undertaken in accordance with manufacturers' instructions, and readings are correct?*					yes
Gas rate:	m ³ /h	OR	ft ³ /h		
Were parts fitted? <small>delete as appropriate</small>		Yes	No		
Parts fitted:					
System inhibitor concentration has been checked and appropriate action taken, in accordance with BS 7593 and boiler manufacturers' instructions. *					yes n/a
Comments:					
Signature:					

*A System inhibitor efficacy test is required on every annual service in accordance with the manufacturers' instructions and BS 7593. It is only acceptable to not have undertaken this if the service engineers attendance visit was in between annual services to attend a non-water facing component.

SERVICE/INTERIM WORK ON BOILER <small>delete as appropriate</small>					Date:
Engineer name:		Company name:			
Telephone N°:		Gas Safe registration N°:			
Max rate	CO	ppm	CO ₂	%	CO/CO ₂
Min rate	CO	ppm	CO ₂	%	CO/CO ₂
Where possible, has a flue integrity check been undertaken in accordance with manufacturers' instructions, and readings are correct?*					yes
Gas rate:	m ³ /h	OR	ft ³ /h		
Were parts fitted? <small>delete as appropriate</small>		Yes	No		
Parts fitted:					
System inhibitor concentration has been checked and appropriate action taken, in accordance with BS 7593 and boiler manufacturers' instructions. *					yes n/a
Comments:					
Signature:					

*A System inhibitor efficacy test is required on every annual service in accordance with the manufacturers' instructions and BS 7593. It is only acceptable to not have undertaken this if the service engineers attendance visit was in between annual services to attend a non-water facing component.

* All installations in England and Wales must be notified to Local Authority Building Control (LABC) either directly or through a Competent Persons Scheme. A Building Regulations Compliance Certificate will then be issued to the customer.

© Heating and Hotwater Industry Council (HHIC)



www.centralheating.co.uk

H Commissioning Flow Chart

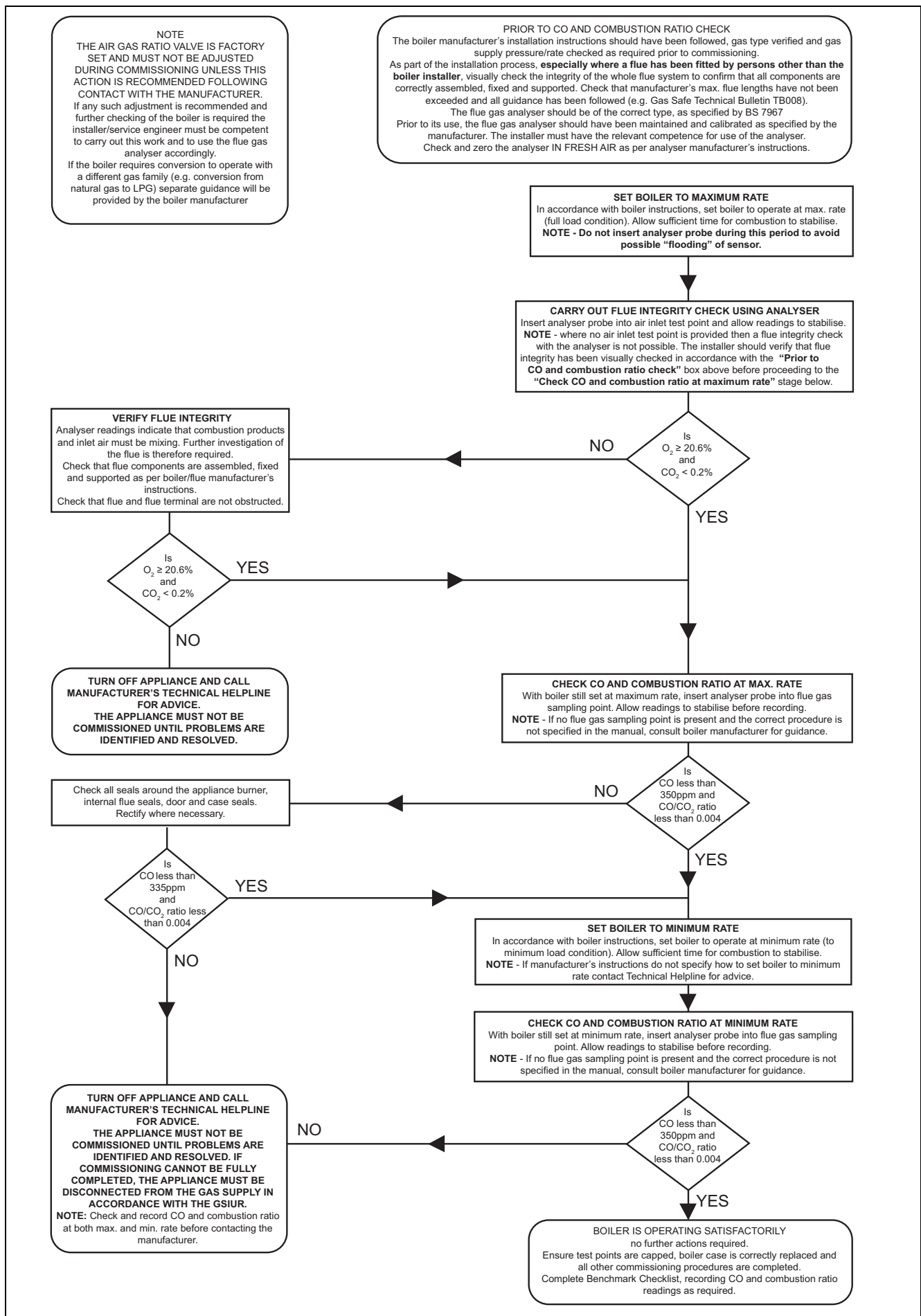

Index

8	
80/125 mm diameter unit connection piece, installing	23
A	
Air/flue pipe connection on the unit	23
Air/flue pipe, connecting	23
Air/flue pipe, horizontal wall duct	17
Air/flue pipe, installing	23
Air/flue pipe, type C13	17
Air/flue pipe, type C33	17
Air/flue pipe, vertical roof duct	17
Article number	11–12
B	
Burner anti-cycling time	33
Burner anti-cycling time, resetting	33
Burner, checking	38
Burner, replacing	41
Bypass, setting	34
C	
Calling up, diagnostics codes	33
CE marking	11
Check programmes, using	27
Checking the pre-charge pressure of the expansion vessel	40
Checking, burner	38
CO ₂ content	
Checking	36
CO ₂ content, checking	32
Comfort protection mode	40
Compact thermal module, installing	39
Compact thermal module, removing	37
Condensate discharge	20
Condensate siphon, cleaning	39
Condensate siphon, filling	30
Connection dimensions	13
Control	25
D	
Diagnostics codes, calling up	33
Diagnostics codes, using	27
Discharge pipe, expansion relief valve	23
Display and setting options	27
Disposal, packaging	44
Disposing of the packaging	44
Documents	11
E	
Electronics box, closing	24
Expansion relief valve	43
F	
Fan, replacing	41
Fault codes	40
Fault memory, calling up	40
Fault symbol	27
Flow rate-pressure curves	34
Frost protection	12
G	
Gas connection value	31
Gas conversion	31
Gas Council Number	11
Gas family check, performing	20
Gas group	20
Gas setting	31
Gas type	20
Gas valve assembly, replacing	41
Guarantee and Customer Service	7
H	
Handing over to the end user	35
Heat exchanger, cleaning	38
Heat exchanger, replacing	42
Heating installation, filling	30
I	
Identification plate	11
Inspection work, carrying out	36
Inspection work, completing	40
Installation, preparations	20
Installer level	27
Installer level, calling up	27
Intended use	4
Internal expansion vessel, replacing	42
K	
Kammerbelüftung	14
L	
Leak-tightness	33, 40
Liquid gas	6, 20
M	
Maintenance interval, setting	34
Maintenance work, carrying out	36
Maintenance work, completing	40
Maximum burner anti-cycling time, setting	33
Maximum heat output, setting	34
Minimum clearance	14
O	
Operating concept	27
Overheating protection	12
P	
PCB for the user interface, replacing	43
PCB, replacing	43
Power supply	24
Preparing, maintenance work	36
Preparing, repair work	41
Pressure sensor	43
Product dimensions	13
Product, draining	40
Product, permanently decommissioning	44
Product, switching off	30
Product, switching on	30
Pump output, setting	34
R	
Regulations	6
Repair work, completing	44
Repair work, preparing	36, 41
S	
Safety devices	12
Scale	20
Scale deposition	20
Scope of delivery	13
Serial number	12
Service message	40
Side section, installing	19
Side section, removing	19
Spare parts	41
Strainer in the cold water inlet, cleaning	39
T	
Treating the heating water	29
U	
Unit connection piece for the air/flue pipe, 80/125 mm diameter	23
Unit connection piece for the air/flue pipe, replacing	23

Unit connection piece, removing	23
V	
Validity of the instructions.....	11
Volume flow sensor	43
W	
Weight	18

Supplier

Vaillant Ltd.

Nottingham Road ■ Belper ■ Derbyshire ■ DE56 1JT

Telephone 0330 100 3461

info@vaillant.co.uk ■ www.vaillant.co.uk

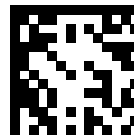

0020253094_06

Publisher/manufacturer

Vaillant GmbH

Berghauser Str. 40 ■ D-42859 Remscheid

Tel. +492191 18 0 ■ Fax +492191 18 2810

info@vaillant.de ■ www.vaillant.de

© These instructions, or parts thereof, are protected by copyright and may be reproduced or distributed only with the manufacturer's written consent.

Subject to technical modifications.