

Installation and service instructions for contractors

VIESSMANN

Vitodens 050-W

Type B0HA, B0KA, 3.2 to 32 kW

Wall mounted gas condensing boiler

Natural gas and LPG version

Type B0KA-M (for multiple connection), 7.0 to 25 kW

Wall mounted gas condensing boiler

Natural gas version

Gas Council No.

- B0KA: 47-819-55, 47-819-57, 47-819-58
- B0KA-M: 47-819-56
- B0HA: 41-819-63, 41-819-64

VITODENS 050-W



Safety instructions

-  Please follow these safety instructions closely to prevent accidents and material losses.

Safety instructions explained

-  **Danger**
This symbol warns against the risk of injury.

-  **Please note**
This symbol warns against the risk of material losses and environmental pollution.

Note
Details identified by the word "Note" contain additional information.

Target group

These instructions are exclusively intended for qualified contractors.

- Work on gas installations may only be carried out by a registered gas fitter.
- Work on electrical equipment may only be carried out by a qualified electrician.
- The system must be commissioned by the system installer or a qualified person authorised by the installer.

Regulations to be observed

- National installation regulations
- Statutory regulations for the prevention of accidents
- Statutory regulations for environmental protection
- Codes of practice of the relevant trade associations
- Relevant country-specific safety regulations

Safety instructions for working on the system

Working on the system

- Where gas is used as the fuel, close the main gas shut-off valve and safeguard it against unintentional reopening.
- Isolate the system from the power supply, e.g. by removing the separate fuse or by means of a mains isolator, and check that it is no longer live.
- Safeguard the system against reconnection.
- Wear suitable personal protective equipment when carrying out any work.

Safety instructions (cont.)**Danger**

Hot surfaces and fluids can lead to burns or scalding.

- Before maintenance and service work, switch OFF the appliance and let it cool down.
- Never touch hot surfaces on the boiler, burner, flue system or pipe-work.

**Please note**

Electronic assemblies can be damaged by electrostatic discharge. Prior to commencing work, touch earthed objects such as heating or water pipes to discharge static loads.

Auxiliary components, spare and wearing parts**Please note**

Auxiliary components, spare parts and wearing parts that have not been tested together with the system can compromise its function. Installing non-authorised components and making non-approved modifications or conversions can compromise safety and may invalidate our warranty. For installation and replacements, use only Viessmann original parts or parts approved by Viessmann.

Repair work**Please note**

Repairing components that fulfil a safety function can compromise the safe operation of the system. Replace faulty components only with genuine Viessmann spare parts.

Safety instructions for operating the system

If you smell gas

-  **Danger**
Escaping gas can lead to explosions which may result in serious injury.
- Do not smoke. Prevent naked flames and sparks. Never switch lights or electrical appliances on or off.
 - Close the gas shut-off valve.
 - Open windows and doors.
 - Evacuate any people from the danger zone.
 - Notify your gas or electricity supply utility from outside the building.
 - Have the power supply to the building shut off from a safe place (outside the building).

If you smell flue gas

-  **Danger**
Flue gas can lead to life threatening poisoning.
- Shut down the heating system.
 - Ventilate the installation site.
 - Close doors to living spaces to prevent flue gases from spreading.

What to do if water escapes from the appliance

-  **Danger**
If water escapes from the appliance there is a risk of electrocution. Switch OFF the heating system at the external isolator (e.g. fuse box, domestic distribution board).

-  **Danger**
If water escapes from the appliance there is a risk of scalding. Never touch hot heating water.

Condensate

-  **Danger**
Contact with condensate can be harmful to health. Never let condensate touch your skin or eyes and do not swallow it.

Flue systems and combustion air

Ensure that flue systems are clear and cannot be sealed, for instance due to accumulation of condensate or other external causes. Ensure an adequate supply of combustion air. Inform system users that subsequent modifications to the building characteristics are not permissible (e.g. cable/pipe-work routing, cladding or partitions).

-  **Danger**
Leaking or blocked flue systems, or an inadequate supply of combustion air can cause life threatening poisoning from carbon monoxide in the flue gas. Ensure the flue system is in good working order. Vents for supplying combustion air must be non-sealable.

Extractors

Operating appliances that extract air to the outside (extractor hoods, extractors, air conditioning units, central vacuum cleaning systems, etc.) can create negative pressure. If the boiler is operated at the same time, this can lead to a reverse flow of flue gas.

Safety instructions (cont.)**Danger**

The simultaneous operation of the boiler and appliances that exhausts air to the outside can result in life threatening poisoning due to a reverse flow of flue gas.

Fit an interlock circuit or take suitable steps to ensure an adequate supply of combustion air.

1. Information	Disposal of packaging	10
	Gas Council No.	10
	Symbols	11
	Intended use	11
	Product information	12
	■ Type plate	12
	System examples	12
	Maintenance parts and spare parts	12
	■ Viessmann Partnership	13
	■ Viessmann spare part app	13
2. Preparing for installation	14
3. Installation sequence	Removing the boiler from the packaging	19
	Mounting the boiler and making connections	20
	■ Removing the front panel	20
	■ Mounting the boiler on the pre-plumbing jig or mounting frame	20
	■ Fitting the boiler to the wall mounting bracket	22
	■ Heating water and DHW connections	24
	Condensate connection	25
	■ Filling the trap with water	25
	Flue gas connection	26
	■ Connecting several Vitodens to a shared flue system	26
	Gas connection	26
	Electrical connections	27
	■ Opening the wiring chamber	27
	■ Overview of electrical connections	28
	■ On-site connections on the HBMU heat management unit	29
	■ Outside temperature sensor	29
	■ Connecting the cylinder temperature sensor	29
	■ Power supply	30
	■ Routing connecting cables/leads	30
	Closing the wiring chamber	31
	Mounting the front panel	31
4. Commissioning, inspection, maintenance	Steps - commissioning, inspection and maintenance	32
5. System configuration (parameters)	Calling up parameters	58
	Parameters	58
	■ 3 Scald protection	58
	■ 4 Max. speed of speed-controlled primary/heating circuit pump in standard mode, heating circuit 1	58
	■ 6 Minimum heating output	59
	■ 7 Maximum heating output	59
	■ 8 Maximum flow temperature limit, heating circuit 1	59
	■ Energy saving functions (setting only via software tool)	59
6. Diagnosis and service checks	Service menu	60
	■ Calling up the service menu	60
	■ Exiting the service menu	60
	Diagnosis	60
	■ Checking operating data	60
7. Troubleshooting	Fault display on the programming unit	62
	Overview of electronics modules	63
	Fault messages	63
	■ 7	63
	■ 8	64
	■ 13	64

- 14 64
- 49 64
- 50 64
- 57 65
- 58 65
- 59 65
- 62 65
- 63 65
- 64 66
- 67 66
- 68 66
- 69 66
- 70 67
- 71 67
- 72 67
- 73 67
- 74 68
- 75 68
- 77 68
- 78 68
- 87 68
- 89 69
- 95 69
- 102 69
- 103 69
- 104 69
- 142 69
- 161 70
- 163 70
- 182 70
- 183 70
- 184 70
- 185 71
- 299 71
- 346 71
- 347 71
- 348 72
- 349 72
- 350, 351 72
- 352 72
- 353 72
- 354 73
- 355 73
- 359 73
- 361 73
- 364 74
- 365 74
- 366, 367 74
- 369 74
- 370 74
- 371 75
- 372 75
- 373 75
- 374 75
- 375 76
- 376 76
- 377 77
- 378 77
- 379 77
- 380 78

■ 381	78
■ 382	78
■ 383, 384	78
■ 385	78
■ 386	79
■ 387	79
■ 388	79
■ 393	79
■ 394	79
■ 399	80
■ 400	80
■ 401	80
■ 402	80
■ 403	80
■ 404	81
■ 405	81
■ 406, 408, 410	81
■ 416	81
■ 417, 418	81
■ 425	81
■ 446	82
■ 447, 448	82
■ 449, 450, 451, 452	82
■ 453	82
■ 454	82
■ 455, 456	83
■ 457	83
■ 458	83
■ 461	83
■ 462	83
■ 463	83
■ 464	84
■ 467	84
■ 468	84
■ 471	85
■ 474	85
■ 527, 528	85
■ 540	85
■ 574	86
■ 575	86
■ 576	86
■ 577	86
■ 578	86
■ 579	87
■ 682	87
■ 683	87
■ 694	87
■ 738	87
■ 766	88
■ 767	88
■ 799	88
■ 979	88
■ 980	88
■ 981	89
■ 982	89
Repairs	89
■ Shutting down the boiler	89
■ Removing the boiler from the pre-plumbing jig or mounting frame	90
■ Checking the temperature sensors	91
■ Replacing the HBMU heat management unit	93

Index (cont.)

	<ul style="list-style-type: none"> ■ Replacing the power cable 93 ■ Replacing the HMI connecting cable 93 ■ Checking the plate heat exchanger 94 ■ Removing the hydraulic unit 95 ■ Checking the fuse 96 	
8. Function description	<ul style="list-style-type: none"> Appliance functions 97 ■ Heating mode 97 ■ OpenTherm controller 97 ■ Venting program 97 ■ Filling program 97 ■ Heating curve 97 DHW heating (system boilers only) 99 External heating circuit hook-up (if installed) 99 	
9. Connection and wiring diagram	<ul style="list-style-type: none"> HBMU heat management unit 100 HBMU heat management unit 102 	
10. Commissioning/service reports	<ul style="list-style-type: none"> Report 104 	
11. Specification	<ul style="list-style-type: none"> Gas condensing combi boiler 106 Flue system types 109 Gas categories 110 Electronic combustion control unit 110 	
12. Disposal	<ul style="list-style-type: none"> Final decommissioning and disposal 111 	
13. Certificates	<ul style="list-style-type: none"> Declaration of conformity 112 	
14. Keyword index	<ul style="list-style-type: none"> 113 	

Information

Disposal of packaging











Please dispose of packaging waste in line with statutory regulations.

Gas Council No.







Type	Gas Council No.:
Vitodens 050-W, B0HA, 19 kW	41-819-63
Vitodens 050-W, B0HA, 25 kW	41-819-64
Vitodens 050-W, B0KA, 25 kW	47-819-55
Vitodens 050-W, B0KA, 30 kW	47-819-57
Vitodens 050-W, B0KA, 35 kW	47-819-58
Vitodens 050-W, B0KA-M, 30 kW	47-819-56

In accordance with the specified directives, this product is designated with 

Symbols

Symbol	Meaning
	Reference to other document containing further information
	Step in a diagram: The numbers correspond to the order in which the steps are carried out.
	Warning of personal injury
	Warning of material losses and environmental pollution
	Live electrical area
	Pay particular attention.
	<ul style="list-style-type: none"> ▪ Component must audibly click into place. or ▪ Acoustic signal
	<ul style="list-style-type: none"> ▪ Fit new component. or ▪ In conjunction with a tool: Clean the surface.
	Dispose of component correctly.
	Dispose of component at a suitable collection point. Do not dispose of component in domestic waste.

The steps in connection with commissioning, inspection and maintenance are found in the "Commissioning, inspection and maintenance" section and identified as follows:

Symbol	Meaning
	Steps required during commissioning
	Not required during commissioning
	Steps required during inspection
	Not required during inspection
	Steps required during maintenance
	Not required during maintenance

Intended use

The appliance is intended solely for installation and operation in sealed unvented heating systems that comply with EN 12828, with due attention paid to CECS215-2017 and the associated installation, service and operating instructions. It is only designed for heating up heating water that is of potable water quality.

Intended use presupposes that a fixed installation in conjunction with permissible, system-specific components has been carried out.

Commercial or industrial usage for a purpose other than heating the building or DHW shall be deemed inappropriate.

Any usage beyond this must be approved by the manufacturer in each individual case.

Incorrect usage or operation of the appliance (e.g. the appliance being opened by the system user) is prohibited and will result in an exclusion of liability. Incorrect usage also occurs if the components in the heating system are modified from their intended use (e.g. if the flue gas and ventilation air paths are sealed).

Product information

Wall mounted gas condensing boiler with Inox-Radial heat exchanger and the following integrated components:

- Modulating Matrix-Plus burner for natural gas
- Hydraulics with 3-way diverter valve and variable speed high efficiency circulation pump
- Type BPKA, B0KA: Plate heat exchanger for DHW heating

- Weather-compensated or constant temperature control unit
 - Integral diaphragm expansion vessel (8 l capacity)
- The selected gas category in the delivered condition and the associated nominal gas pressure are given on the boiler type plate. The type plate also shows the other gas types and pressures with which the boiler can be operated. A conversion within the stated natural gas groups is not required.

Type plate

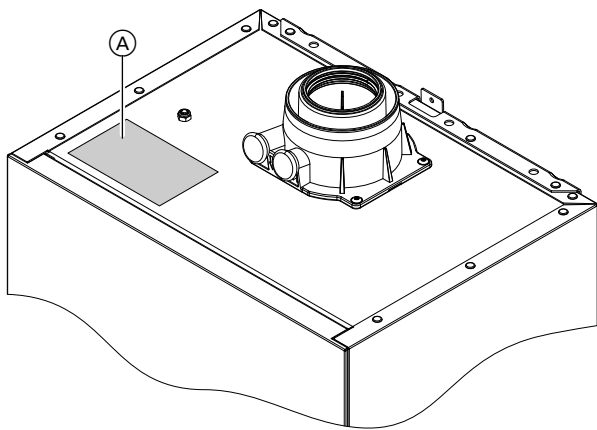

Fig. 1

- Ⓐ Type plate with access code for appliance registration

The type plate of the heat generator contains extensive product information and an appliance-specific **access code with the marking "i"** for direct access to product-specific information and product registration on the internet.

The access code contains the credentials for the registration and product information portal, and the 16-digit serial number.

Note

A further label with the access code is enclosed with the heat generator.

Stick the label in the installation and service instructions so it can be easily found again for later use.

The Vitodens may generally only be delivered to the countries listed on the type plate. For deliveries to other countries, approved contractors must arrange individual approval on their own initiative and in accordance with the law of the country in question.

System examples

System examples with hydraulic and electrical connection diagrams and function descriptions are available to help setting up the heating system.

Detailed information regarding system examples: www.viessmann-schemes.com

Maintenance parts and spare parts

Maintenance parts and spare parts can be identified and ordered directly online.

Maintenance parts and spare parts (cont.)

Viessmann Partnership

Login:
<https://shop.viessmann.com/>



Viessmann spare part app

www.viessmann.com/etapp



Preparing for installation

19 and 25 kW, type B0KA, B0HA, BPKA

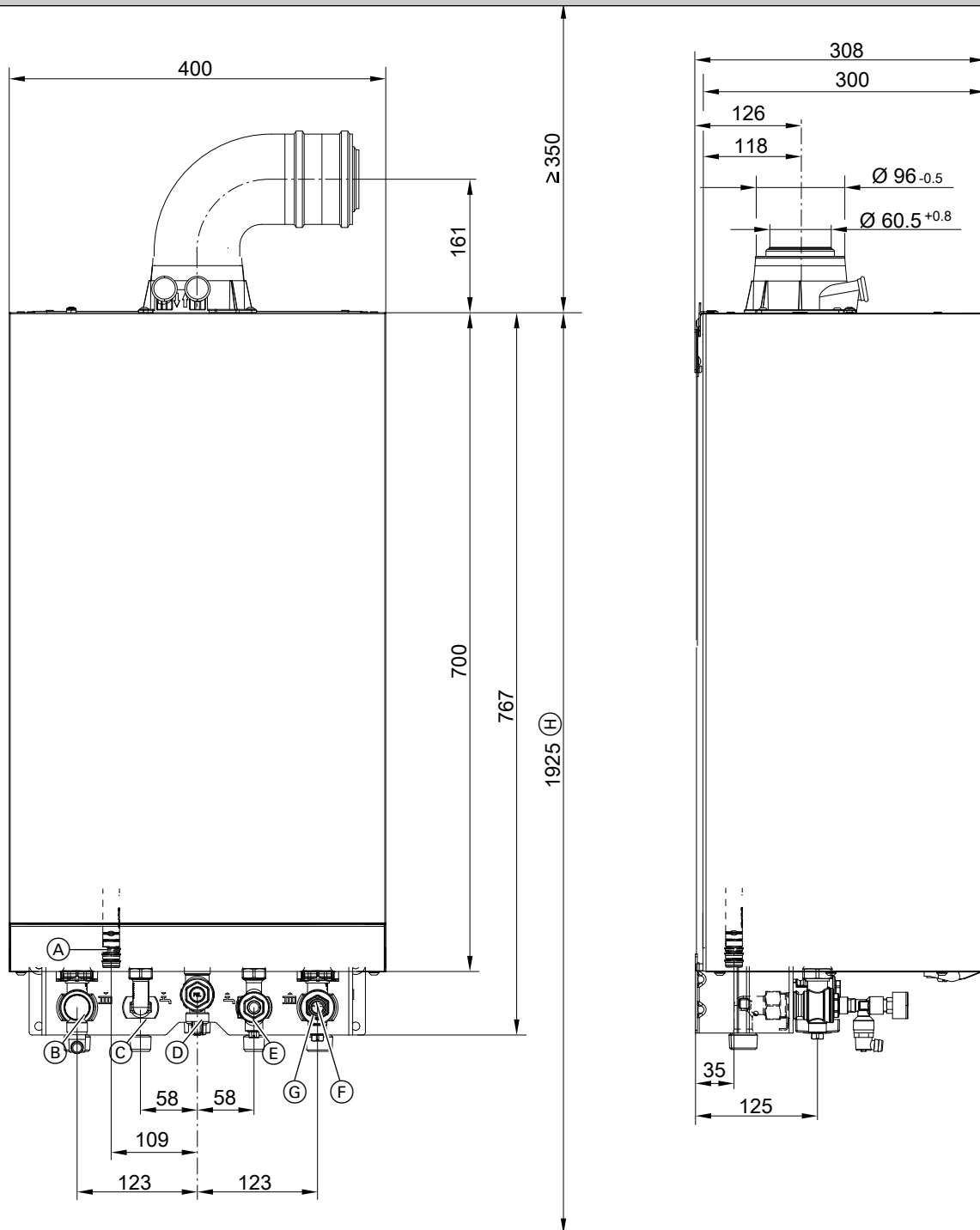
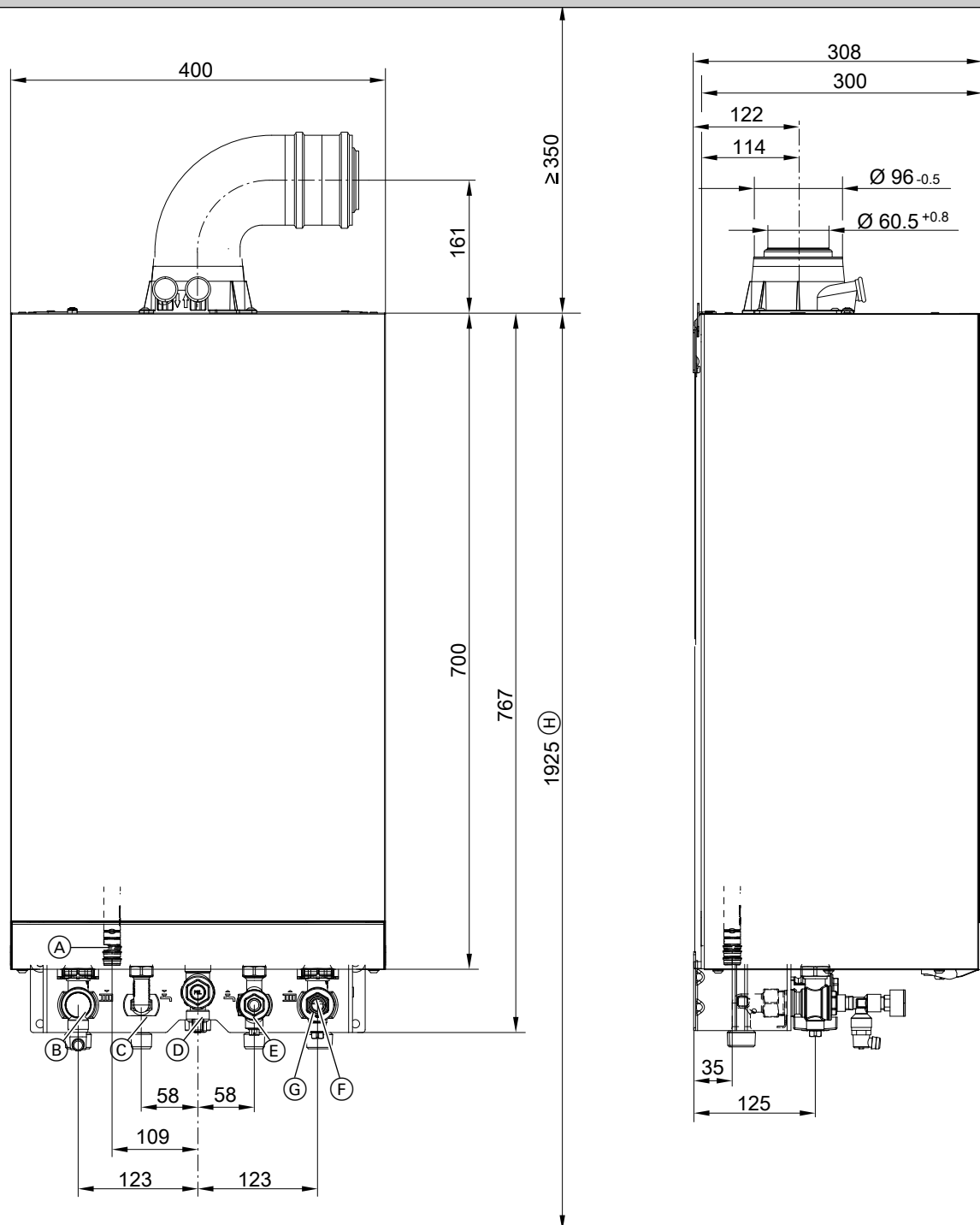

Fig. 2 Illustration shows a gas condensing combi boiler

- (A) Condensate drain
- (B) Heating flow
- (C) DHW (gas condensing combi boiler)
Cylinder flow (gas condensing system boiler)
- (D) Gas connection
- (E) Cold water (gas condensing combi boiler)
Cylinder return (gas condensing system boiler)
- (F) Heating return
- (G) Filling/draining
- (H) Dimension for siting with DHW cylinder below the boiler

Preparing for installation (cont.)

32 kW, type B0KA



Installation

Fig. 3 Illustration shows a gas condensing combi boiler

- (A) Condensate drain
- (B) Heating flow
- (C) DHW (gas condensing combi boiler)
Cylinder flow (gas condensing system boiler)
- (D) Gas connection
- (E) Cold water (gas condensing combi boiler)
Cylinder return (gas condensing system boiler)
- (F) Heating return
- (G) Filling/draining
- (H) Dimension for siting with DHW cylinder below the boiler

Preparing for installation (cont.)

Note

This boiler (IP rating: IP X4) is approved for installation in wet rooms inside safety zone 1, to DIN VDE 0100. Exposure to jets of water must be prevented. For open flue operation, the boiler may only be operated with a splash cover. Observe the requirements of DIN VDE 0100.

Fitting the pre-plumbing jig

1. Subject to order: Fit supplied pre-plumbing jig, mounting frame or wall mounting bracket in the relevant installation location.



Installation instructions for pre-plumbing jig or mounting frame

Note

Check the condition of the wall where the boiler is to be installed. For the suitability of the supplied rawl plugs for various building materials, see manufacturer's instructions: Fischer expansion plugs SX 10 x 80. For other construction materials, use fixing materials with sufficient load bearing capacity.

2. Prepare the water connections to the valves/fittings of the mounting bracket. Thoroughly flush the heating system.



Please note

To prevent damage to the appliance, connect all pipework so that it is free of load and torque stress.

Note

If an on-site expansion vessel also has to be installed: Install this expansion vessel in the cylinder return, as the 3-way diverter valve is located in the heating flow. Not possible with type BOKA

3. Prepare the gas connection according to TRGI or TRF [or local regulations].

4. Prepare the electrical connections.

- The appliance is delivered fitted with a power cable (approx. 2 m long).

Note

Connect the power cable to the electricity supply using a fixed connection.

- Power supply: 230 V, 50 Hz, fuse rating max. 16 A
- Accessory cables: 0.75 mm² flexible PVC cable with required number of cores for external connections
Accessory cables: 1.5 mm² flexible PVC cable with required number of cores for external connections

Preparing for installation (cont.)

Connection on the DHW side for gas condensing combi boiler

Cold water installation

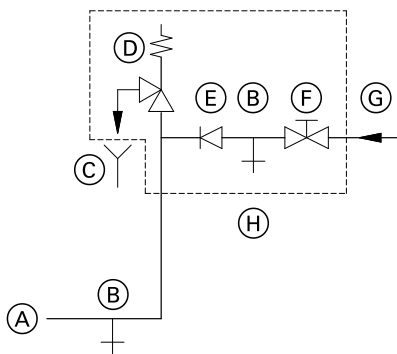

Fig. 4

- (A) Cold water connection of boiler
- (B) Drain outlet
- (C) Visible discharge pipe outlet point
- (D) Safety valve
- (E) Non-return valve
- (F) Shut-off valve
- (G) Cold water
- (H) Safety assembly

Safety assembly (H) is included in the standard delivery and requires installing.

Only use a non-return valve or a combined shut-off and non-return valve in conjunction with a safety valve. If the safety valve is used, the cold water shut-off valve on the boiler must not be shut off. Remove the toggle on the cold water shut-off valve (if installed) to prevent it being shut off manually.

Shock arrestor

If draw-off points likely to cause water hammer are connected to the boiler's DHW network (e.g. flush valves, washing machines, dishwashers): Shock arrestors should be installed close to the cause of the water hammer.

WiFi operational reliability and system requirements

WiFi router system requirement

- WiFi router with activated WiFi:
 - The WiFi router must be protected by a sufficiently secure WPA2 password.
 - The WiFi router must always have the latest firm-ware update.
 - Do not use unencrypted connections between the heat generator and the WiFi router.
- Internet connection with high availability:
 - "Flat rate" (flat rate tariff without restriction on time or data volume)
- Set the WiFi frequency to 2.4 GHz.
- Dynamic IP addressing (DHCP, delivered condition) in the network (WiFi):
 - Have this checked on site by an IT expert **prior** to commissioning. Arrange for set up if required.
- Set routing and security parameters in the IP network (LAN).

Note

Length of password and permitted special characters depend on the respective router.

Enable the following ports for direct outgoing connections:

- Port 80
- Port 123
- Port 443
- Port 8883

Have this checked on site by an IT expert **prior** to commissioning. Set up enabling if required.

Wireless signal range of WiFi connection

The range of wireless signals may be reduced by walls, ceilings and interior fixtures. The following circumstances will reduce the strength of the wireless signal and can disrupt reception:

- On their way between transmitter and receiver, wireless signals are **damped**, e.g. by air or when penetrating walls.
- Wireless signals are **reflected** by metallic objects, e.g. reinforcements embedded in walls, metal foil of thermal insulation and thermal glazing with metalised thermal vapour deposit.
- Wireless signals are **isolated** by service ducts and lift shafts.
- Wireless signals are **disrupted** by devices that also operate with high frequency signals. Distance to such appliances: **Min. 2 m**.
Examples of devices with high frequency signals:
 - Computers
 - Audio and video systems
 - Devices with active WiFi connection
 - Electronic transformers
 - Pre-ballasts

Install the heat generator as close as possible to the WiFi router to ensure a good WiFi connection. The signal strength can be displayed on the programming unit: See operating instructions.

Note

The WiFi signal strength can be increased with commercially available WiFi repeaters.

Angle of penetration

The reception quality remains best if radio signals hit the walls vertically.

Depending on the angle of penetration, the effective wall thickness changes and so does the extent to which the electromagnetic waves are damped.

Flat (unfavourable) angle of penetration

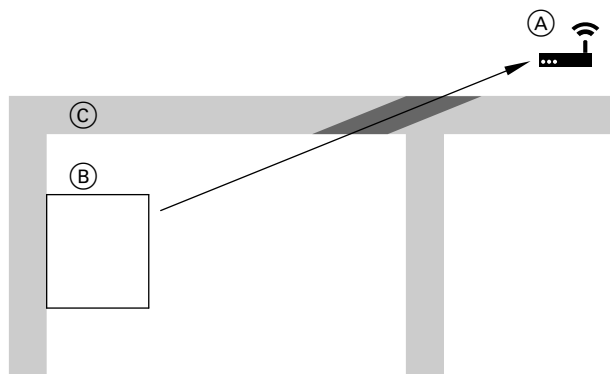

Fig. 5

- (A) WiFi router
- (B) Heat generator
- (C) Wall

Ideal angle of penetration

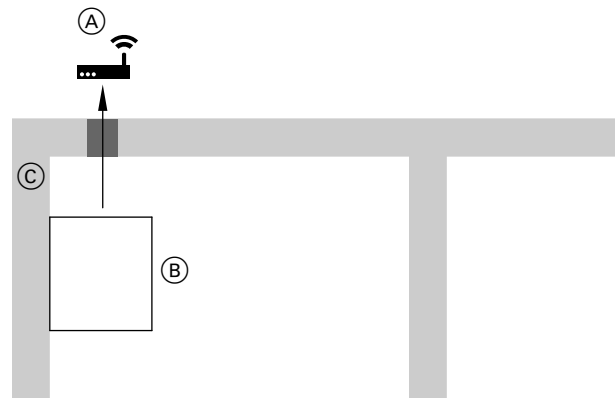

Fig. 6

- (A) WiFi router
- (B) Heat generator
- (C) Wall

Removing the boiler from the packaging

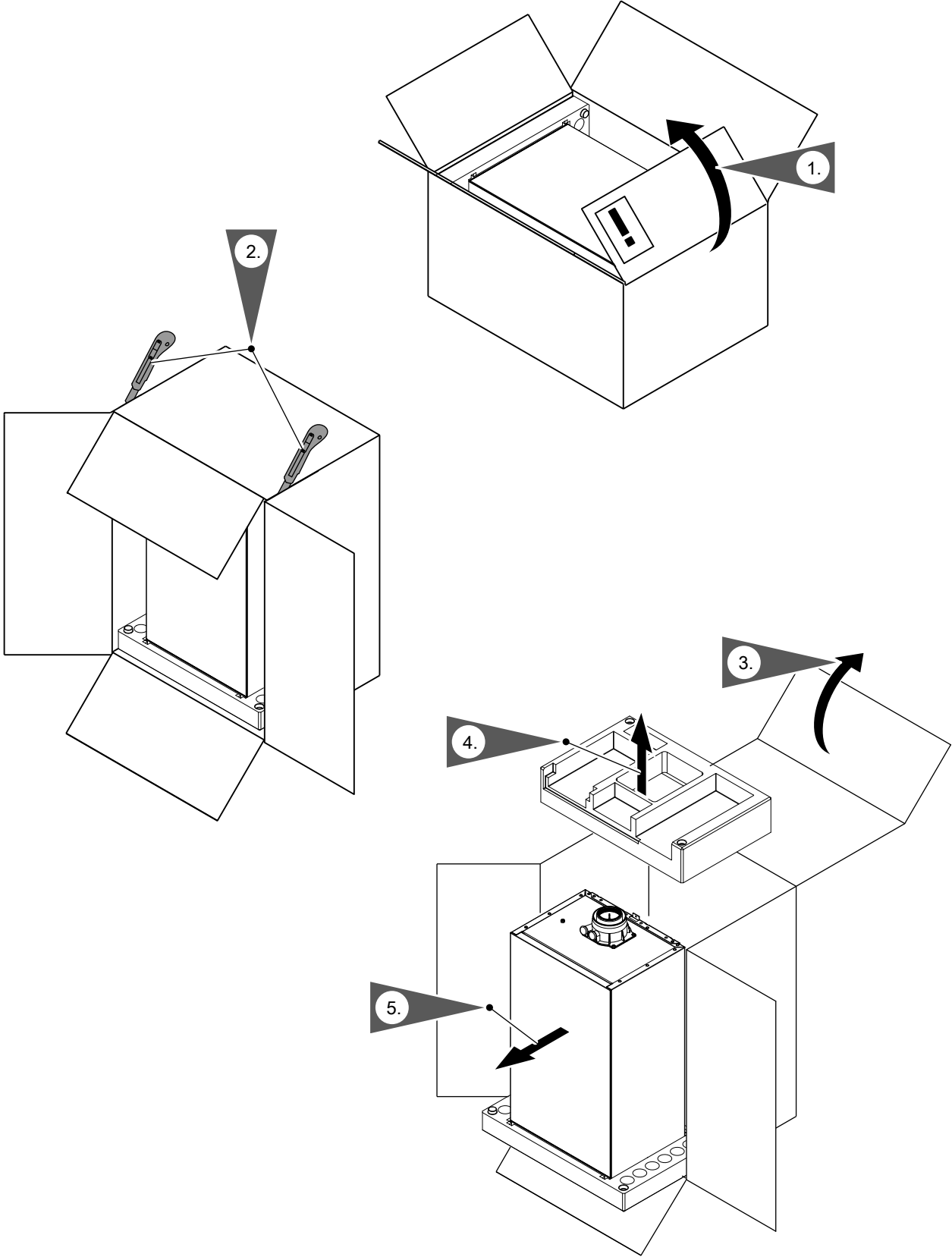

Fig. 7

Removing the front panel

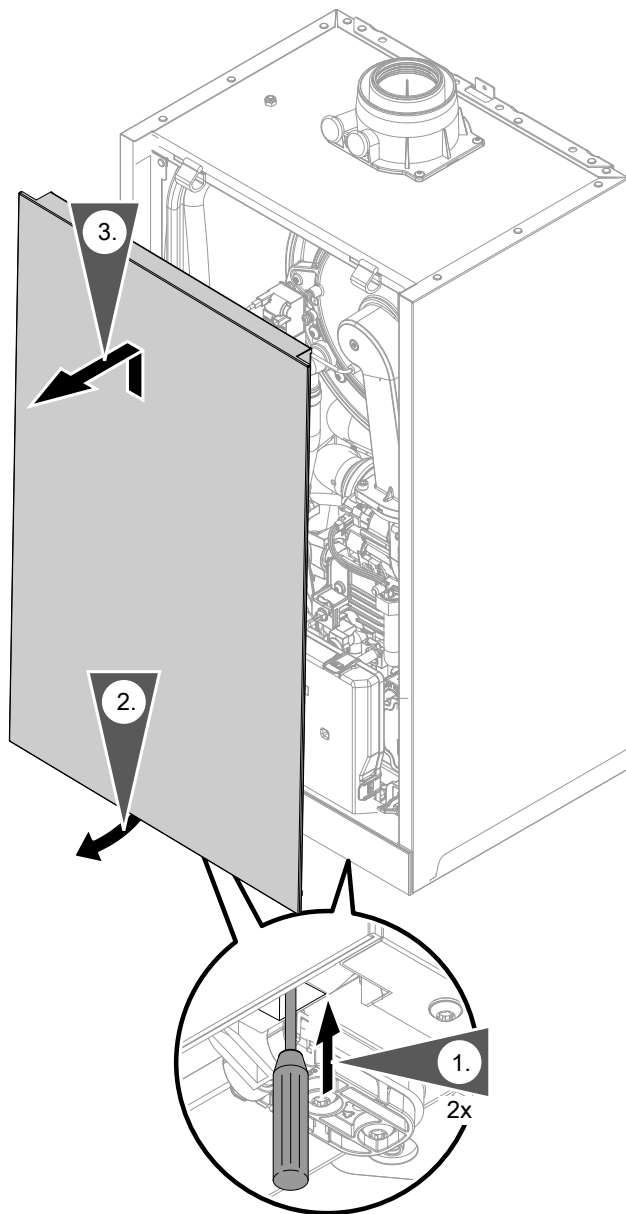

Fig. 8

1. Unlock the front panel on the underside (push in), using a screwdriver or similar tool.
2. Swivel the front panel forward slightly...
3. ... and pull up to remove.

Mounting the boiler on the pre-plumbing jig or mounting frame

Note

Various installation components can be found in a separate pack. Keep the installation components safe, as they will be required for later installation.

Mounting the boiler and making connections (cont.)

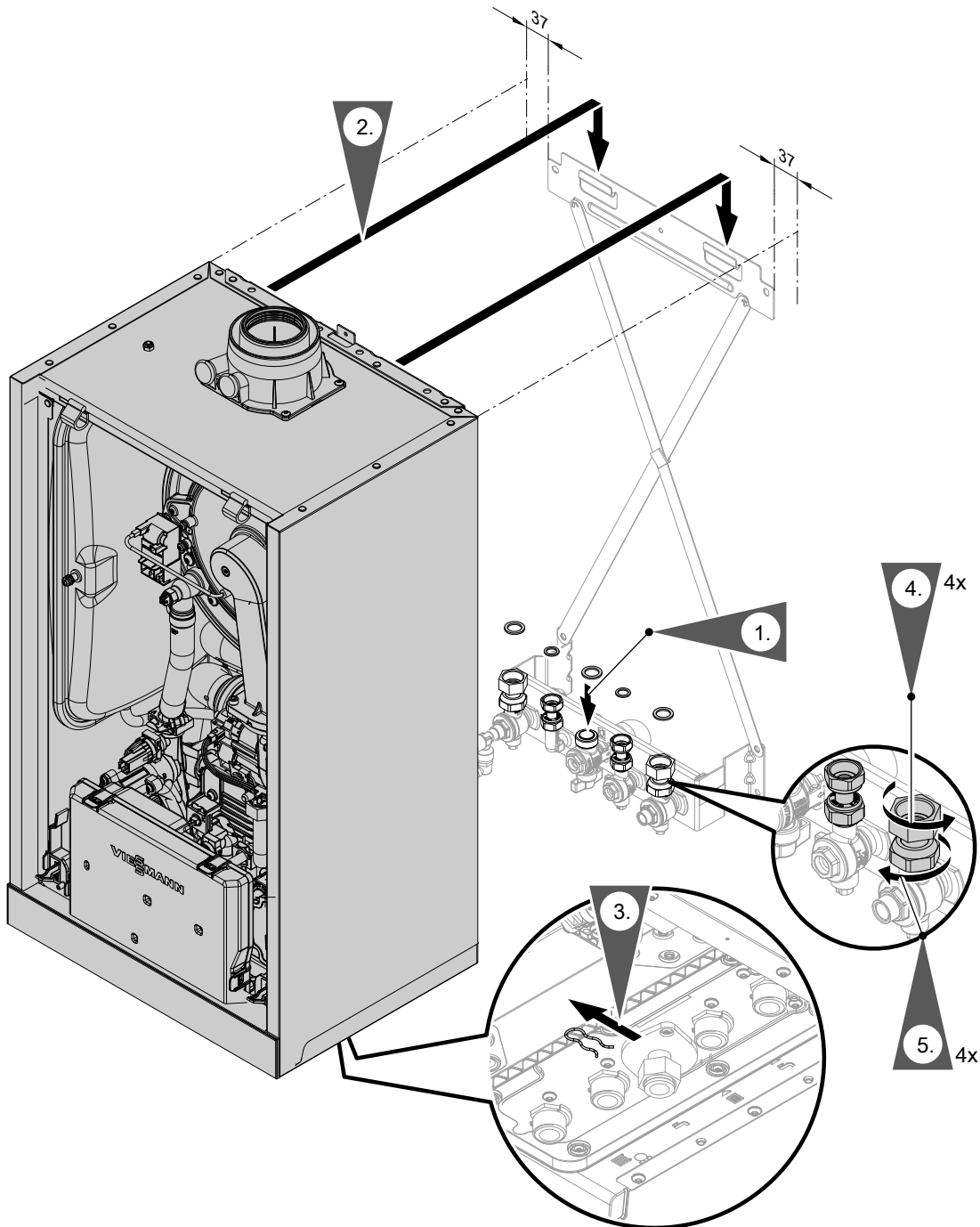

Fig. 9

Note

The diagram shows installation on a pre-plumbing jig for a gas condensing combi boiler.

The boiler can be installed on the following accessories:

- Pre-plumbing jig
- Mounting frame
- Plumbing wall mounting frame

1. Replace gaskets.

Internal gasket diameter:

- Gas connection Ø 18.5 mm
- Connections on the heating water side Ø 17.0 mm

Note

Gasket for gas connection is attached to the gas shut-off valve.

2. Suspend the Vitodens from the wall mounting bracket.
After mounting, check for correct positioning.

Mounting the boiler and making connections (cont.)

3. Only remove the locking clip under the gas pipe union nut once the appliance has been installed. Clip is no longer required.
4. Tighten union nuts so that they form a tight seal. Tighten the union nuts as tightly as necessary and ensure that the components are undamaged and are functioning correctly throughout service life. Observe torque settings if a torque wrench is available. Check for gas tightness to BSI 6891.
5. Tighten locking ring fittings so that they form a tight seal:
1 turn beyond finger-tight

Torque settings:

- Union nuts G $\frac{3}{4}$: 30 Nm
- Union nuts G $\frac{1}{2}$: 24 Nm

When carrying out any work on gas connection fittings, hold with a suitable tool. Never transfer any forces to the internal components.

Fitting the boiler to the wall mounting bracket

Note

Various installation components can be found in a separate pack. Keep the installation components safe, as they will be required for later installation.

Mounting the boiler and making connections (cont.)

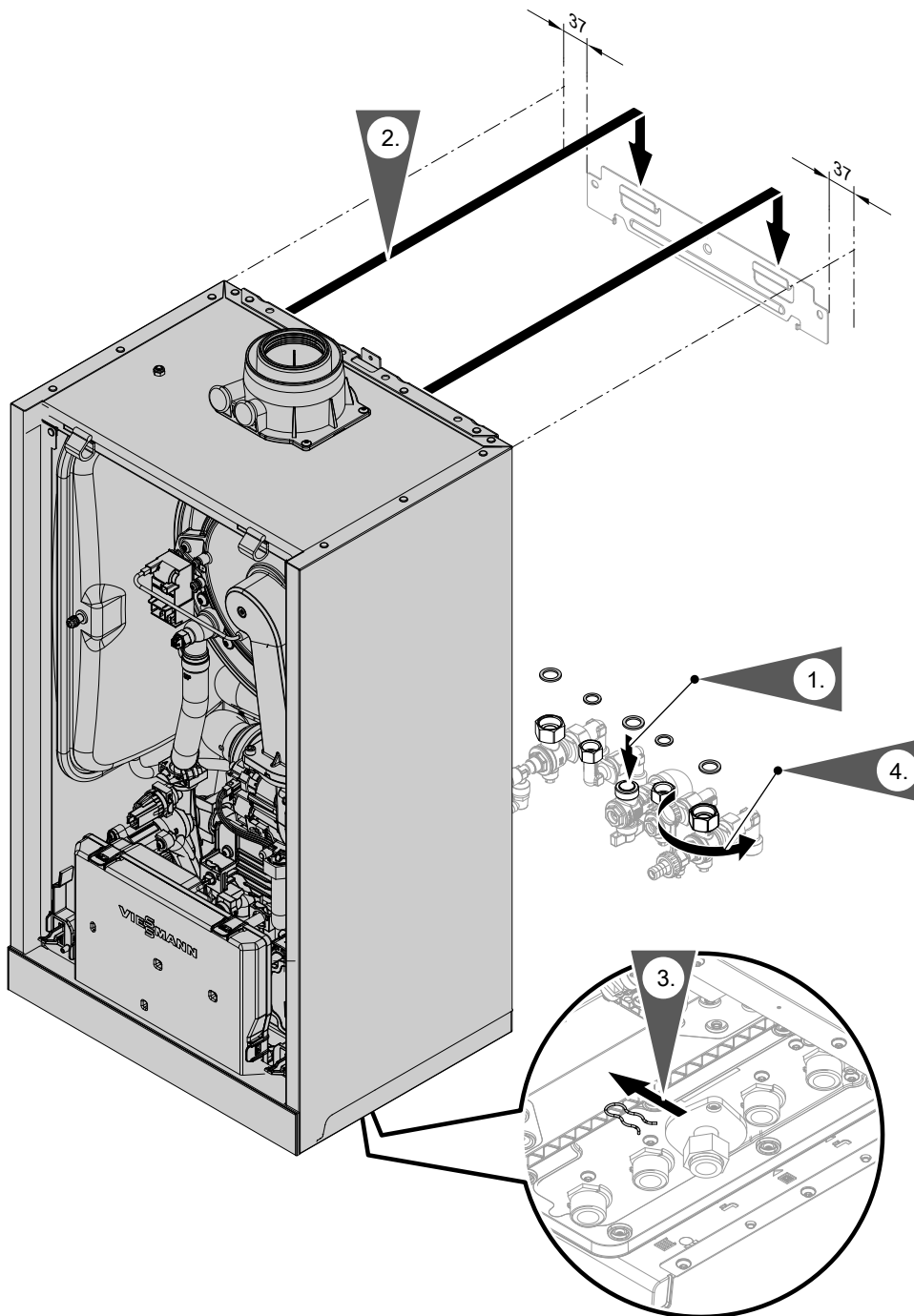

Fig. 10

1. Replace gaskets. Fit valves and gas shut-off valve.

Internal gasket diameter:

- Gas connection $\text{\O} 18.5 \text{ mm}$
- Connections on the heating water side $\text{\O} 17.0 \text{ mm}$

Note

Gasket for gas connection is attached to the gas shut-off valve.

2. Suspend the Vitodens from the wall mounting bracket.

3. **Note**

Only remove the locking clip under the gas pipe union nut once the appliance has been installed. Clip is no longer required.

Mounting the boiler and making connections (cont.)

- Tighten union nuts so that they form a tight seal. Tighten the union nuts as tightly as necessary and ensure that the components are undamaged and are functioning correctly throughout service life. Observe torque settings if a torque wrench is available. Check for gas tightness to BSI 6891.

Torque settings:

- Union nuts G ¾: 30 Nm
- Union nuts G ½: 24 Nm

When carrying out any work on gas connection fittings, hold with a suitable tool. Never transfer any forces to the internal components.

Installation

Heating water and DHW connections

If the connections have not been fitted previously, make the connections on the heating water and DHW sides.

Gas condensing system boiler

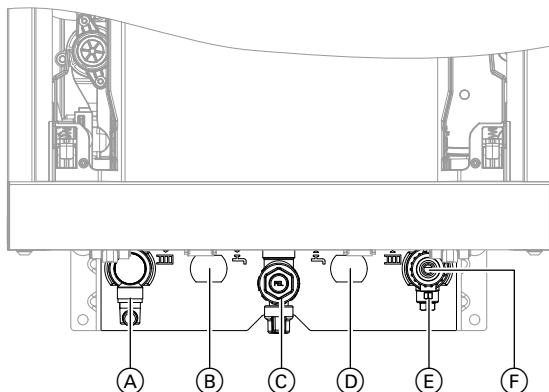

Fig. 11 Specifications for threads in conjunction with connection accessories

- (A) Heating flow locking ring with nut W 1 ⅝"x14 (male thread)
- (B) Cylinder flow G ¾ (male thread)
- (C) Gas connection locking ring with nut M 22x1.5 (male thread)
- (D) Cylinder return G ¾ (male thread)
- (E) Heating return locking ring with nut W 1 ⅝"x14 (male thread)
- (F) Filling/draining

Connection on the heating water side of the DHW cylinder:

The required intermediate pieces (Rp ¾, female thread) on the cylinder flow and cylinder return are part of the connection set for the DHW cylinder. If no DHW cylinder is being connected, seal off the connections with caps.

Gas condensing combi boiler

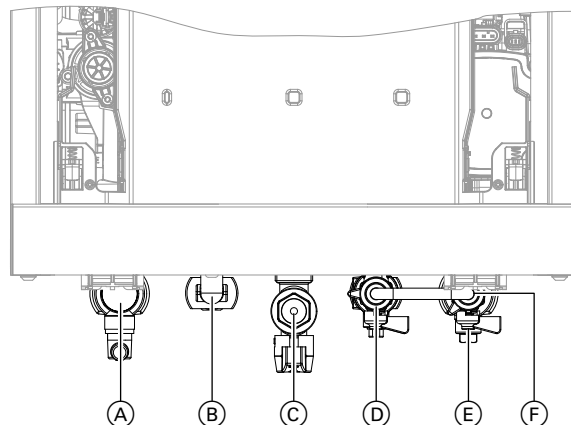

Fig. 12 Specifications for threads in conjunction with connection accessories

- (A) Heating flow locking ring with nut W 1 ⅝"x14 (male thread)
- (B) DHW locking ring with nut G ½ (male thread)
- (C) Gas connection locking ring with nut M 22x1.5 (male thread)
- (D) Cold water locking ring with nut G ½ (male thread)
- (E) Heating return locking ring with nut W 1 ⅝"x14 (male thread)
- (F) Filling/draining

Scald protection

DHW temperatures of over 60 °C can occur with gas condensing combi boilers. Scald protection should therefore be installed on site in the DHW pipe.

Condensate connection

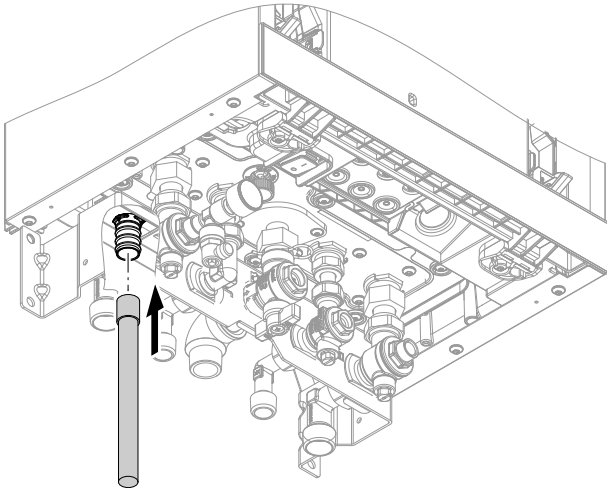

Fig. 13

1. Push the supplied drain hose on to the drain connector.
2. Connect the drain hose with a constant fall and a pipe vent to the drain network or a neutralising system.

Note

Route the onward drain line inside the building as far as possible.

If the onward drain line is routed outside the building:

- Use a min. \varnothing 30 mm line.
- Protect the line from frost.
- Keep the line as short as possible.



Please note

The drain hose is used to route away any hot water discharged from the safety valve. Lay and secure the drain hose in a way that prevents any risk of scalding.

Note

Observe local waste water regulations.

Filling the trap with water

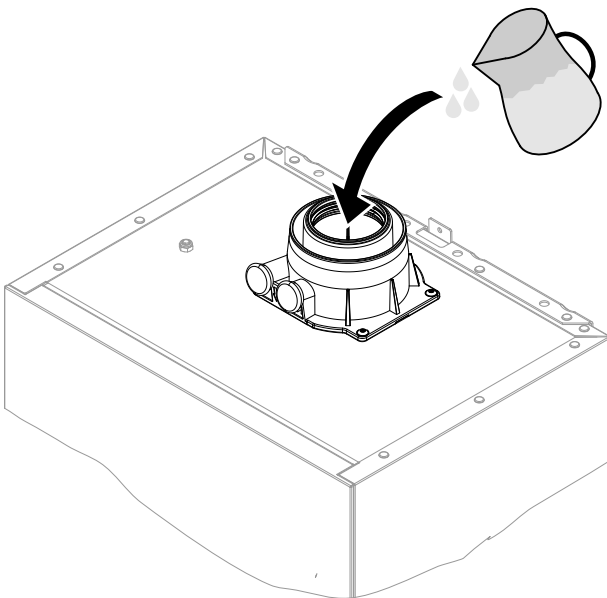

Fig. 14

Pour at least 0.3 l of water into the flue gas connection.



Please note

During commissioning, flue gas may escape from the condensate drain. Always fill the trap with water before commissioning.

Note

If there is a risk of frost, only fill the trap just before commissioning.

Flue gas connection

Note

The labels "System certificate" and "Skoberne GmbH or Gropalli flue system" enclosed with the technical documentation may only be used in conjunction with the Viessmann flue system made by Skoberne or Gropalli.



Connecting the balanced flue pipe
Flue system installation instructions

Connecting several Vitodens to a shared flue system

If several Vitodens boilers are being connected to a flue system at positive pressure in accordance with routing type C₁₀, C₁₁, C₁₃ or C₁₄, Vitodens models suitable for multiple connection are available for this purpose.

Note

Not all appliance types are approved for "multiple connection".

Vitodens models **suitable for multiple connection** must be ordered for this; see pricelist.

In appliances for "multiple connection", a special back draught safety device is installed in the mixing shaft of the burner, downstream of the fan.

A further back draught safety device (order separately) must be installed in the flue system above the boiler flue connection.

Commissioning should be carried out only once the following conditions have been met:

- Unrestricted flow along the flue gas routes
- Positive pressure flue system is gas-tight.
- Inspection port covers checked for secure and tight seating.
- Apertures for supplying sufficient combustion air are open and cannot be closed.
- All current regulations on installing and commissioning flue systems have been observed.



Danger

Leaking or blocked flue systems, or an inadequate supply of combustion air, can cause life threatening poisoning from carbon monoxide in the flue gas.

Ensure the flue system is in good working order. Apertures for combustion air supply must be non-sealable.

Prevent condensate drainage via a wind protector.

Gas connection

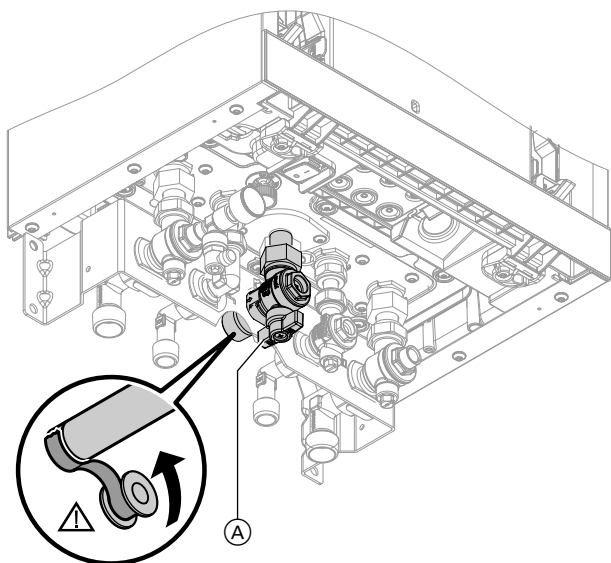

Fig. 15

1. If the gas connection has not been fitted previously, seal gas shut-off valve (A) to the gas connection.

When carrying out any work on gas connection fittings, hold with a suitable tool. Never transfer any forces to the internal components.

Gas connection (cont.)

2. Check for leaks.

Note

Only use suitable and approved leak detection agents (EN 14291) and devices for the leak test. Leak detection agents with unsuitable constituents (e.g. nitrides, sulphides) can cause material damage.

Remove residues of the leak detection agent after testing.

**Danger**

Escaping gas leads to a risk of explosion. Check all connections on the gas side (also inside the appliance) for tightness.

**Please note**

Excessive test pressure will damage the boiler and gas solenoid valve. Max. test pressure 150 mbar (15 kPa). If a higher pressure is required for leak detection, disconnect the boiler and the gas solenoid valve from the main supply pipe (undo the fitting).

3. Purge the gas line.

Electrical connections**Opening the wiring chamber**

Fig. 16

**Please note**

Electronic assemblies can be damaged by electrostatic discharge. Prior to commencing any work, touch earthed objects such as heating or water pipes to discharge static loads.

Overview of electrical connections

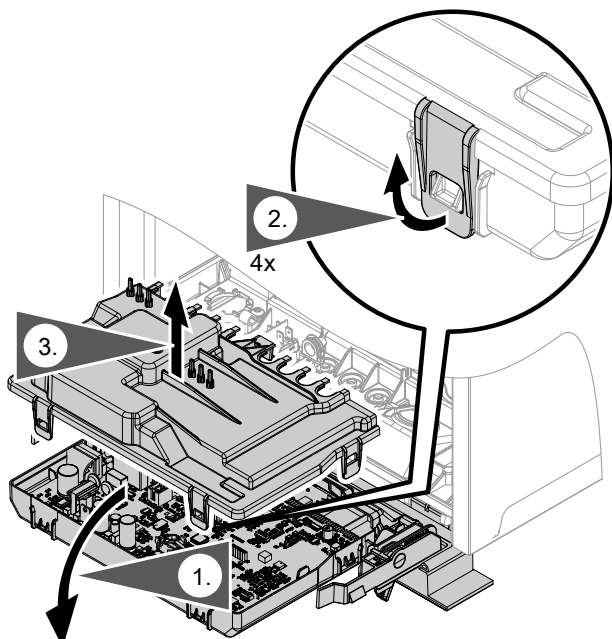
Note

For further information on the connections, see the following chapters.

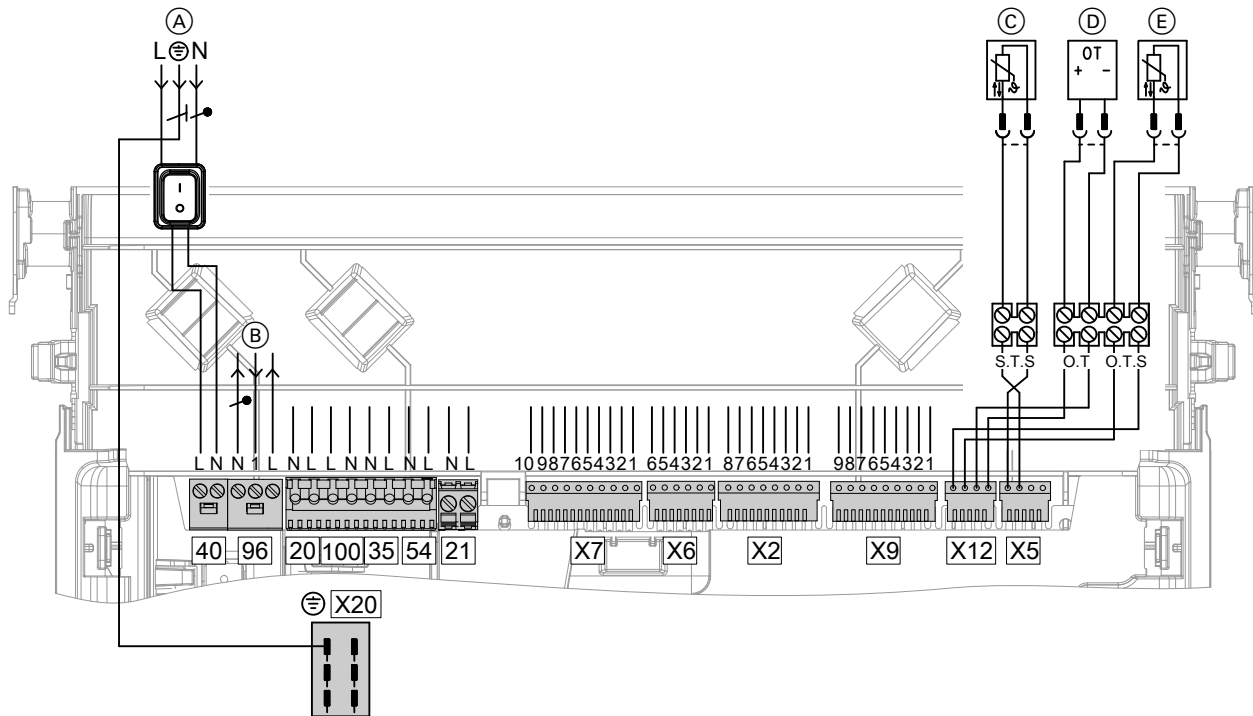

Fig. 17

Connections to 230 V~ plugs

- (A) Power supply [40]
- (B) Configurable floating input [96], 230 V
230 V output
230 V room thermostat connection
- (C) Cylinder temperature sensor (system boiler)
- (D) Remote control (OpenTherm controller)
- (E) Outside temperature sensor
- [20] Heating circuit pump
- [100] Fan motor

- [35] Gas solenoid valve
- [54] Ignition unit/ionisation
- [21] No function assigned
- X[20] Equipotential bonding (earth conductor)



Note on connecting accessories

When connecting accessories observe the separate installation instructions provided with them.

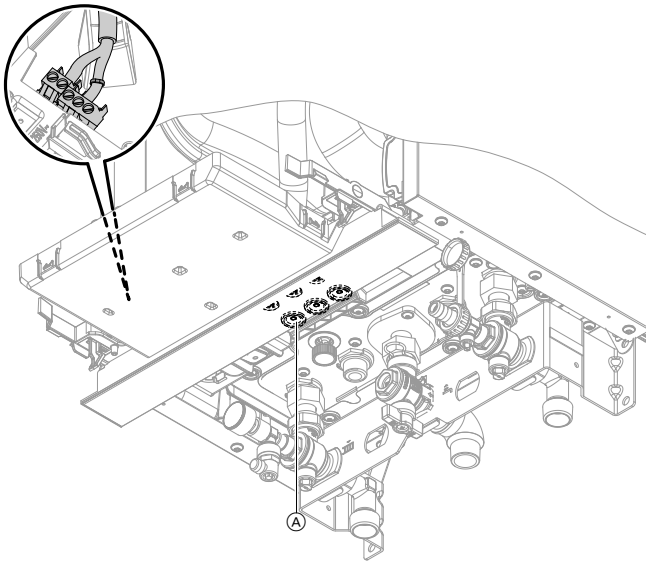
Electrical connections (cont.)**On-site connections on the HBMU heat management unit**

- Open diaphragm grommets as required. Thread through only one cable at a time without a plug. Ensure diaphragm grommets are airtight. If required, remove plug from cable. After threading the cable through, refit the plug with wire ferrules.
- For cables without strain relief bushings, provide strain relief in the wiring chamber in the form of cable ties.

Fig. 18

Ⓐ Diaphragm grommets for cables

Outside temperature sensor**Fitting location for outside temperature sensor**

- North or north-westerly wall, 2 to 2.5 m above ground level; in multi storey buildings, in the upper half of the second floor
- Not above windows, doors or vents
- Not immediately below balconies or gutters
- Never render over.

Outside temperature sensor connection

See page 28.
2-core lead, length up to 35 m with a cross-section of 1.5 mm²

Connecting the cylinder temperature sensor

Connect cylinder temperature sensor to terminals Ⓔ.
See page 28.

Power supply

Power supply 40



Danger

Incorrectly executed electrical installations can result in injuries from electrical current and damage to the appliance.

Connect the power supply and implement all safety measures (e.g. RCD circuit) in accordance with the following regulations:

- IEC 60364-4-41
- IEEE Wiring Regulation; BS 7671:2018
- Connection conditions of the local grid operator

- Install an isolator in the power cable to provide omnipolar separation from the mains for all active conductors, corresponding to overvoltage category III (3 mm) for complete isolation. The isolator must be fitted in the permanent electrical installation, in line with installation requirements.

We also recommend installing a pulse current-sensitive RCD (RCD class A).

- Connect the power cable to the electricity supply using a fixed connection.

- If the power supply to the appliance is connected with a flexible power cable, ensure that the live conductors are pulled taut before the earth conductor in the event of strain relief failure. The length of the earth conductor wire will depend on the design.
- Max. fuse rating 16 A.



Danger

The absence of system component earthing can lead to serious injury from electric current if an electrical fault occurs.

The appliance and pipework must be connected to the equipotential bonding of the building.

Routing connecting cables/leads



Please note

If closures or diaphragm grommets are damaged, splashproofing is no longer ensured. Do not open or damage closures or unused diaphragm grommets on the underside of the appliance. Seal cable entries with fitted diaphragm grommets.

Bundle cables using the supplied cable clips. Route extra low voltage (ELV) leads < 42 V separately from cables > 42 V/230 V~.

Secure the cable clips on the underside using the supplied screws.

Do not route cables/leads over sharp edges or against the casing (sound transmission).



Please note

If connecting cables/leads come into contact with hot components, they will be damaged. When routing and securing cables/leads on site, ensure that the maximum permissible temperatures for these cables/leads are not exceeded.

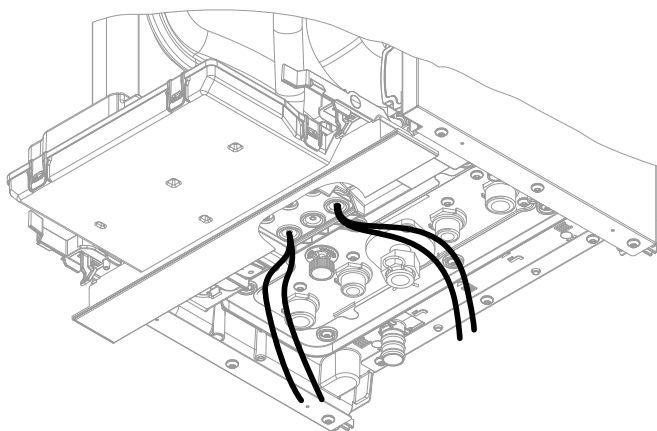

Fig. 19

Closing the wiring chamber

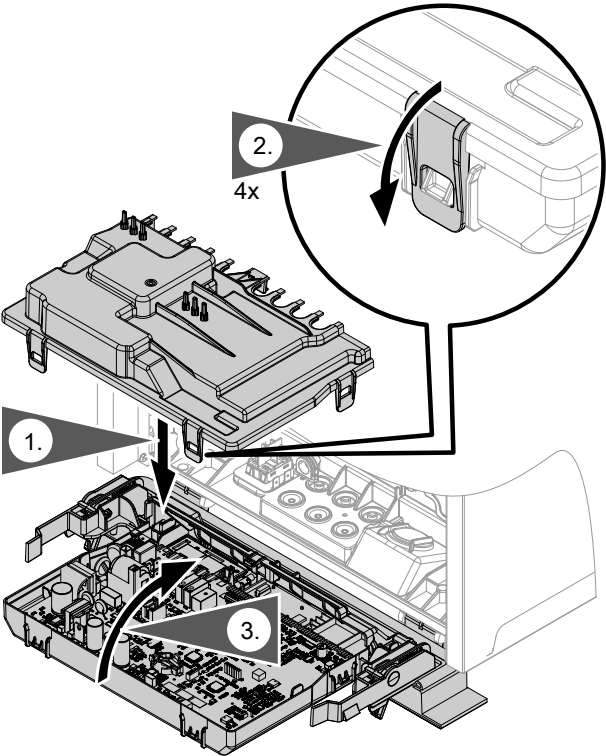

Fig. 20

Mounting the front panel

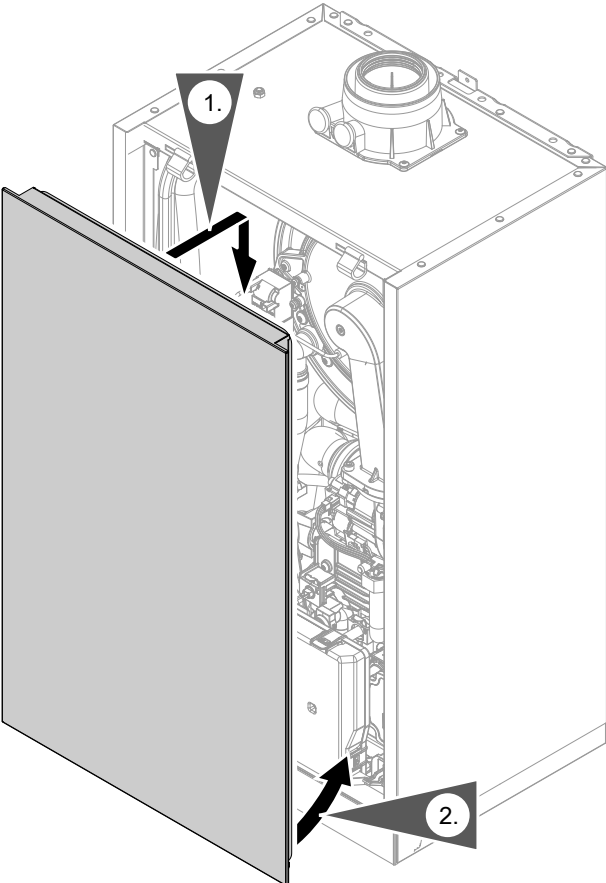

Fig. 21



			Page
•	•	•	1. Commissioning the system..... 33
•	•	•	2. Filling the heating system..... 35
•	•	•	3. Checking all connections on the heating water and DHW sides for leaks..... 37
•	•	•	4. Venting the heating system..... 37
•	•	•	5. Checking the gas type..... 38
•	•	•	6. Removing the front panel..... 38
•	•	•	7. Checking the static pressure and supply pressure..... 39
•	•	•	8. Function sequence and possible faults..... 41
•	•	•	9. Setting the maximum heating output..... 42
•	•	•	10. Performing an actuator test..... 42
•	•	•	11. Adjusting the integral circulation pump rate..... 42
•	•	•	12. Checking the balanced flue system for leaks (annular gap test)..... 45
•	•	•	13. Burner adjustment when connecting multiple flues to a shared flue system..... 45
•	•	•	14. Removing the burner..... 46
•	•	•	15. Checking the burner gasket and burner gauze assembly..... 47
•	•	•	16. Checking and adjusting the ignition and ionisation electrodes..... 49
•	•	•	17. Checking the back draught safety devices..... 50
•	•	•	18. Cleaning the heating surfaces..... 51
•	•	•	19. Checking the condensate drain and cleaning the trap..... 52
•	•	•	20. Installing the burner..... 53
•	•	•	21. Checking the neutralising system (if installed)
•	•	•	22. Checking the flow limiter (only for gas condensing combi boiler)..... 54
•	•	•	23. Checking the expansion vessel and system pressure..... 54
•	•	•	24. Checking the safety valve function
•	•	•	25. Checking the electrical connections for firm seating..... 55
•	•	•	26. Checking all gas equipment for leaks at operating pressure..... 55
•	•	•	27. Fitting the front panel..... 55
•	•	•	28. Checking the combustion quality..... 56
•	•	•	29. Checking the flue system for unrestricted flow and leaks
•	•	•	30. Matching the control unit to the heating system..... 57
•	•	•	31. Adjusting the heating curve..... 57
•	•	•	32. Instructing the system user..... 57



Commissioning the system

- ! Please note**
Only start the appliance with a fully filled trap.
Check that the trap has been filled with water.

Commissioning via commissioning assistant

1. Open the gas shut-off valve.
2. If the appliance has not been switched on yet: Turn on the ON/OFF switch.
Call up the commissioning assistant:
 1. **≡** and **OK** simultaneously for approx. 4 s.
 2. Use **^**/**v** to select "**b.5**" and confirm with "**OK**".

Note
AP and **📶** appear on the display. Confirm with **OK** to start the connection with the software tool: See chapter "Commissioning via software tool".

 3. **≡** for 4 s to start the commissioning assistant via the heat generator display.
3. Further steps can be found in the commissioning assistant: See following overview.

Commissioning via software tool

Note

Apps for commissioning and service are available for iOS and Android devices.



1. Open the gas shut-off valve.
2. **AP** and **📶** appear on the display.
Press **OK** to carry out commissioning with the software tool.
3. Select **ON** and confirm with **OK**.
4. Follow the instructions in the software tool.

Commissioning assistant sequence	Explanations and references (value in bold is factory setting)
Commissioning	
"C.1" Date (day, month, year)	Note <i>C.1-C.3 only appear if a ViCare thermostat or Vitotrol 100-E is connected.</i>
"C.2" Time (hours, minutes)	
"C3" Automatic summer/winter-time changeover	ON = on OF = off (factory setting)
"C.4" Operating mode	4 - Weather-compensated 13 - Constant mode with optional room thermostat 14 - OpenTherm 15 - Individual room control 16 - Individual room control with modulation Note <i>Operating modes 15 and 16 can only be set via the software tool. If operating mode 15 or 16 is set, low power radio cannot be switched off.</i>
"C.5" Filling program	ON = on OF = off Note <i>It is possible to interrupt or end the process while a rotating rectangle alternating with the current system pressure is displayed; to do so, press ≡ for 3 s.</i>



Commissioning assistant sequence	Explanations and references (value in bold is factory setting)
"C.6" Venting program	ON = on OF = off Note <i>It is possible to interrupt or end the process while a rotating rectangle alternating with the current system pressure is displayed; to do so, press ≡ for 3 s.</i>
"Adv" commissioning	Note <i>"En" appears after "C.6". If this is confirmed with "OK", the Advanced Setup is skipped and the flue gas temperature sensor test starts. If the up arrow button is pressed (continue) while "En" is shown, "Ad" appears on the display. If this is confirmed with "OK", the Advanced Setup starts with "C.7".</i>
"C.7" Gas type	2 - Natural gas CPG 3 - LPG (not for appliances with multiple connection)
"C.8" Flue system	1 - Open flue 60 mm 2 - Room sealed 60/100 mm 3 - Open flue 80/125 mm 4 - Room sealed 80/125 mm 5 - Flexible 60 mm (room sealed or open flue) max. 10 m 6 - Flexible 80 mm (room sealed or open flue) max. 20 m
"C.9" Flue length	Given in full metres (round up if necessary) Note <i>An additional length of 1 m must be factored in for every flue bend.</i>
"C.10" System scheme (depending on appliance type, not all schemes possible)	1 - 1 direct heating circuit without low loss header 3 - 1 direct heating circuit without low loss header with DHW cylinder
"C.11" External heating circuit hook-up	Note <i>Only for weather-compensated operation.</i> 0 - No external heating circuit hook-up 1 - External heating circuit hook-up HC1
	After the final setting has been completed, "En" appears on the display. Confirm with "OK". When commissioning starts, the flue gas temperature sensor test begins and "Fs" is shown on the display.

The system carries out a restart.

Automatic flue gas temperature sensor check

The display shows: "Er"

If the flue gas temperature sensor is not positioned correctly, fault message 416 appears.

For further details regarding the flue gas temperature sensor test, see "Repairs".

If fault message 416 appears, reposition the flue gas temperature sensor in the flue gas connection. Check for leaks on the flue gas side.

Note

The burner remains locked out until the test has been passed.

When the fault has been remedied, turn the ON/OFF switch off and back on again.



Commissioning the system (cont.)

Switching WiFi on/off

The appliance is equipped with an integrated (2.4 GHz) WiFi communication module with extended type plate.

This WiFi communication module supports commissioning, maintenance and servicing with "ViGuide"/"ViGuide app" as well as operation via the "ViCare app".

Three labels with the access details required for establishing the connection are attached at the factory to the front of the programming unit. The access code is marked with a "WiFi symbol" .

Remove these 3 labels. Apply the labels in the following positions:

- For commissioning, affix a label to the place marked on the type plate.
- Affix a label in the space provided in the operating instructions.
- For later use, affix a label here:

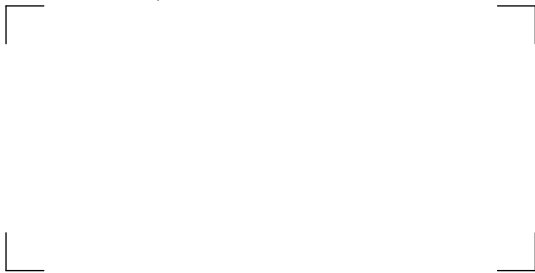



Fig. 22

Switch on the WiFi connection. Establish a connection to the router:

- Information on WiFi: See chapter "WiFi operational reliability and system requirements".
-  **Establishing an internet connection**
Operating instructions

Note

If "E10" is displayed, the connection to the home network could not be established. Check the router and the network password.

If "E12" is displayed, the connection to the server could not be established. Re-establish the connection at a later time.

Note

If the communication module is to be switched on or off, press  and **OK** simultaneously for 4 s.



Filling the heating system

Fill water

As a heat transfer medium for DHW heating, the heating water must meet fluid category ≤ 3 . This requirement is met if water of potable quality is used as heating water. For example, if additives are used, the additive manufacturer must specify which category the treated heating water comes under.

! Please note

- Unsuitable fill water increases the level of deposits and corrosion and may lead to appliance damage.
 - Flush the heating system thoroughly before filling.
 - Only use fill water of potable water quality.
 - Special antifreeze suitable for heating systems can be added to the fill water. The antifreeze manufacturer must verify its suitability.
 - Fill and top-up water with a water hardness above 300 ppm must be softened, e.g. with a small softening system for heating water.

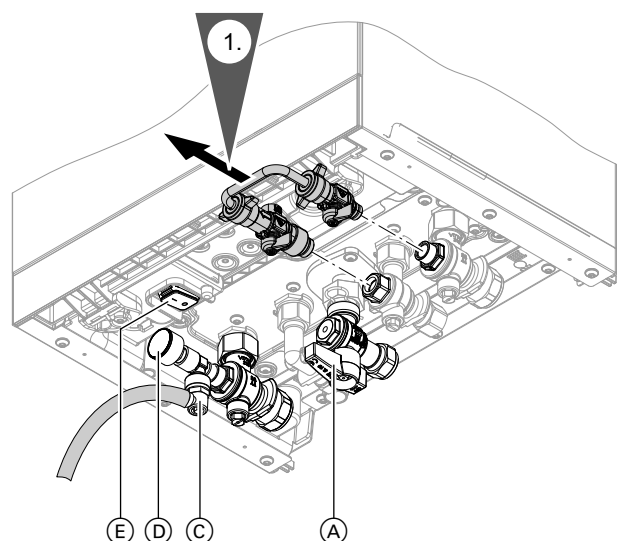

Fig. 23

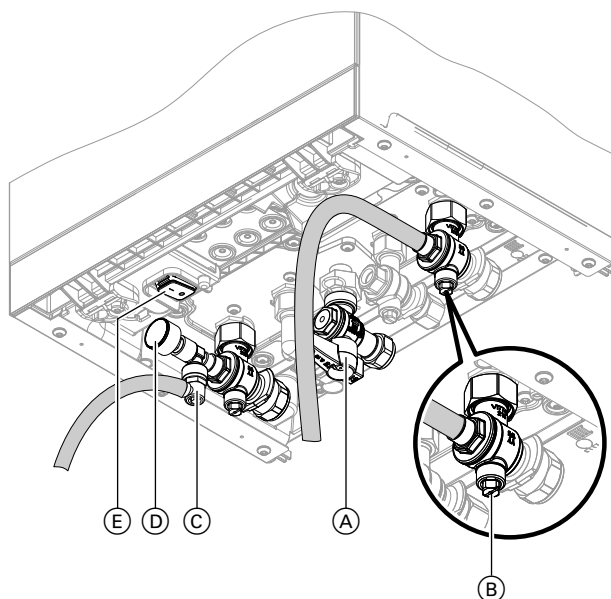

Fig. 24

1. Check the pre-charge pressure of the expansion vessel.
2. Close gas shut-off valve (A).
3. Activate the filling function (see commissioning assistant or following chapter).
4. Fill the heating system at boiler drain & fill valve (B) in the heating return (on the connection set or on site). Minimum system pressure > 1.0 bar (0.1 MPa). Check the system pressure at pressure gauge (D). The indicator must be in the green band. If necessary, open the on-site air vent valves.
5. Fit hose to air vent valve (C). Route the hose into a suitable container or drain outlet.
6. Close the shut-off valves on the heating water side.
7. Open air vent valve (C) and fill valve (B) in the heating return. Vent (flush) under mains pressure until no more air noise is audible.
8. Close air vent valve (C) and boiler drain & fill valve (B). Check the system pressure at pressure gauge (D). The indicator must be in the green band.
9. Open the shut-off valves on the heating water side.





Note

Ensure that the safety valve does not respond when you are filling the system. If the flow rate through the safety valve becomes too high, water may enter the combustion chamber.

Activating the filling function

If the filling function is to be activated after commissioning.

Tap the following buttons:

1.  and **OK** simultaneously for approx. 4 s.
2. Use  to select "b.5" for the commissioning assistant.
3. **OK**
4. The display shows "AP". Press  for 4 s.
5. Use  to select "C.1" for the filling function.
6. **OK**
7.  to select "ON" for filling.



Filling the heating system (cont.)

8. OK

The filling function is activated. The display shows a rotating rectangle.

The filling function ends automatically after 20 min or press for 4 s.



Checking all connections on the heating water and DHW sides for leaks



Danger

There is a risk of electric shock from escaping heating water or DHW.

When commissioning and after carrying out maintenance work, check all water side connections for leaks.



Please note

Leaking hydraulic connections lead to appliance damage.

- Check the internal and on-site hydraulic connections for leaks.
- In the event of leaks, switch off the appliance immediately. Drain the heating water. Check the seating of seal rings. **Always** replace displaced seal rings.



Venting the heating system

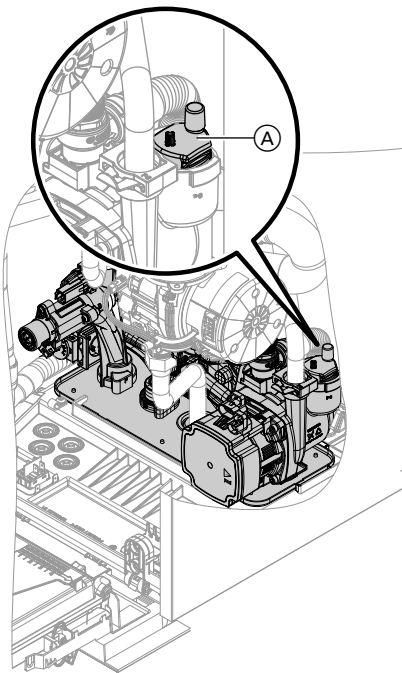

Fig. 25

1. Check whether the air vent screw in quick-action air vent valve (A) of the heating circuit pump is open.
2. Close the gas shut-off valve and switch the appliance ON.
3. Activate the venting program (see commissioning assistant or following chapter).
4. Adjust the system pressure.
The display shows the system pressure.
5. Disconnect the supply hose from the boiler drain & fill valve.
6. Open the gas shut-off valve.

Note

Leave the quick-action air vent valve open once the venting program has finished.



Venting the heating system (cont.)

Activating the venting function

If the venting function is to be activated after commissioning.

Tap the following buttons:

1. and **OK** simultaneously for approx. 4 s, then release.
2. Use to select "**b.5**" for the commissioning assistant.
3. **OK**
4. The display shows "**AP**". Press for 4 s.
5. Use to select "**C.2**" for venting.
6. **OK**
7. should be used to select "**ON**" to switch on venting.
8. **OK**
The venting function is activated. The display shows a rotating rectangle. The venting function ends automatically after 20 min, or press for 4 s.



Checking the gas type

The boiler is equipped with an electronic combustion controller that adjusts the burner for optimum combustion in accordance with the prevailing gas quality.

- Operation with natural gas therefore requires no adjustment across the entire Wobbe index range. The boiler can be operated within the Wobbe index range 9.5 to 15.2 kWh/m³ (34.2 to 54.7 MJ/m³).
- For operation with LPG, the gas type needs to be changed on the control unit (see following chapter).

1. Determine the gas type and Wobbe index by asking your local gas supply utility or LPG supplier.
2. Record the gas type in the report.

Changing the gas type for operation with LPG (not for appliances with multiple connection)

1. To change the gas type on the control unit, see "Commissioning the system with the commissioning assistant"
2. Affix label "G31" (supplied with the technical documentation) next to the type plate on the cover panel.

Note

No mechanical adjustments are made to the gas solenoid valve.



Removing the front panel



Danger

Contact with live components can lead to serious injury from electric current. Some components on PCBs remain live even after the power supply has been switched off.

- **Never touch** the wiring chambers (control unit and power supply connections).
- When working on the appliance, isolate the system from the power supply, e.g. at a separate MCB/fuse or a mains isolator. Check the system is no longer live and safeguard against reconnection.
- Prior to working on the appliance, wait at least 4 min until the voltage has completely dropped out.



Removing the front panel (cont.)

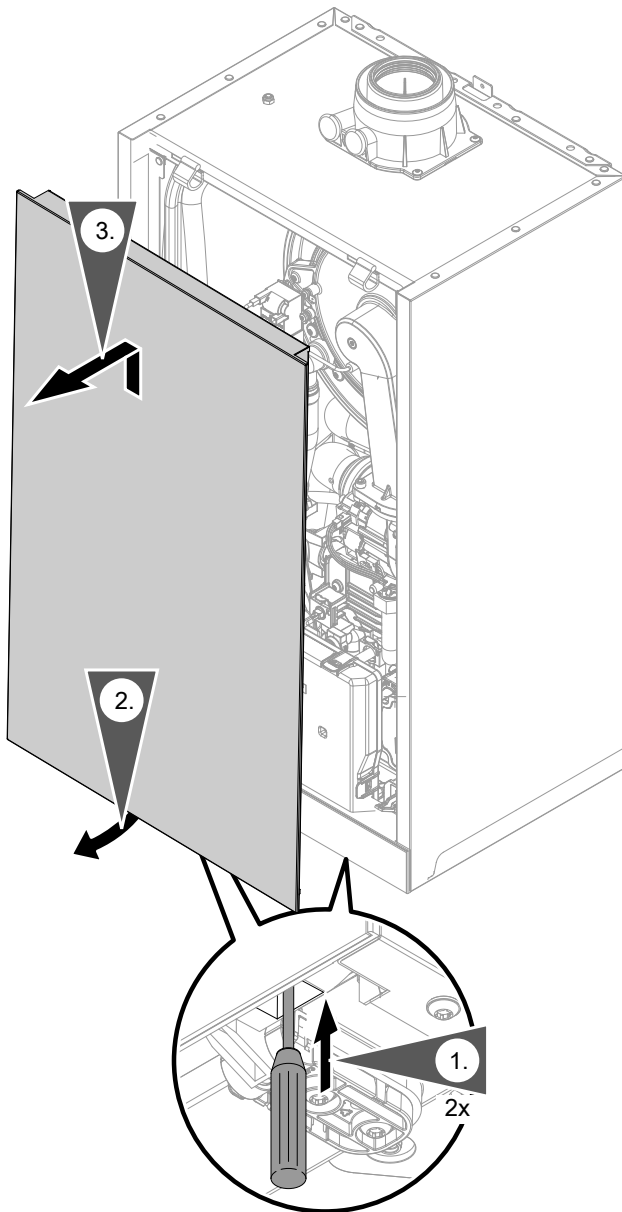

Fig. 26



Checking the static pressure and supply pressure



Danger
CO formation as a result of incorrect burner adjustment can have serious health implications. Always carry out a CO test before and after work on gas appliances.

Note

Operation with LPG:
Purge the LPG tank twice on commissioning/replacement. Vent the tank and gas connection line thoroughly after purging.

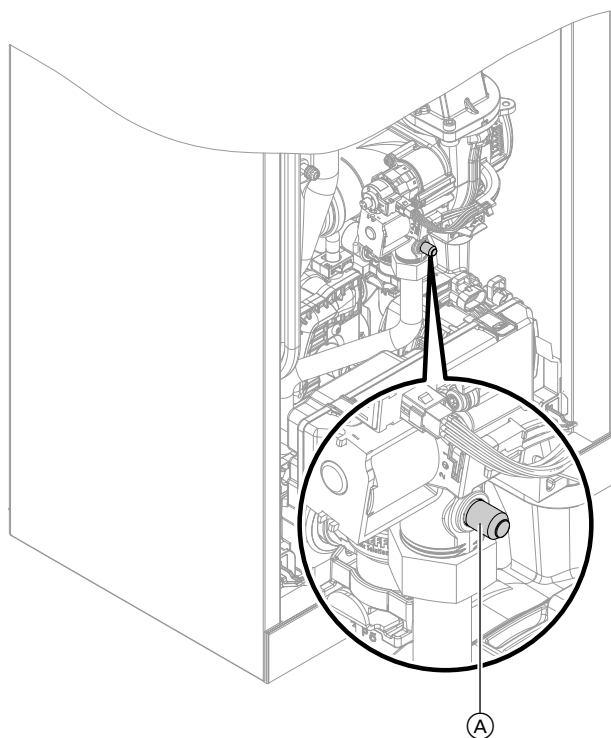

Fig. 27

1. Turn off the ON/OFF switch.
2. Close the gas shut-off valve.
3. Undo screw (A) in the test connector on the gas solenoid valve, but do not remove it. Connect the pressure gauge.
4. Open the gas shut-off valve.
5. Measure the static pressure and record it in the report.
Set value: Max. 57.5 mbar (5.75 kPa).
6. Turn on the ON/OFF switch and start the boiler.

Note

During commissioning, the appliance can enter a fault state if there are airlocks in the gas line. Reset the appliance after approx. 5 s (see operating instructions).

7. Measure the supply (flow) pressure. For set values, see the following table.

Note

Use a suitable measuring device with a resolution of at least 0.1 mbar (0.01 kPa) to check the supply pressure.

8. Record the measured value in the report. Implement measures as indicated in the table below.
9. Shut down the boiler. Close the gas shut-off valve. Remove the pressure gauge. Use the screw to close test connector (A).
10. Open the gas shut-off valve and start the appliance.



Danger

Gas escaping from the test connector leads to a risk of explosion. Check gas tightness at test connector (A).

11. Fit front panel (see installation sequence).

Supply pressure (flow pressure)		Measures
With natural gas	For LPG	
< 13 mbar (1.3 kPa)	< 25 mbar (2.5 kPa)	Do not start the appliance. Notify the gas supply utility or LPG supplier.
13 to 25 mbar (1.3 to 2.5 kPa)	25 to 57.5 mbar (2.5 to 5.75 kPa)	Start the boiler.
> 25 mbar (2.5 kPa)	> 57.5 mbar (5.75 kPa)	Connect a separate gas pressure governor upstream of the system. Set the pre-charge pressure to 20 mbar (2.0 kPa) for natural gas and 50 mbar for LPG. Notify the gas supply utility or LPG supplier.



Function sequence and possible faults

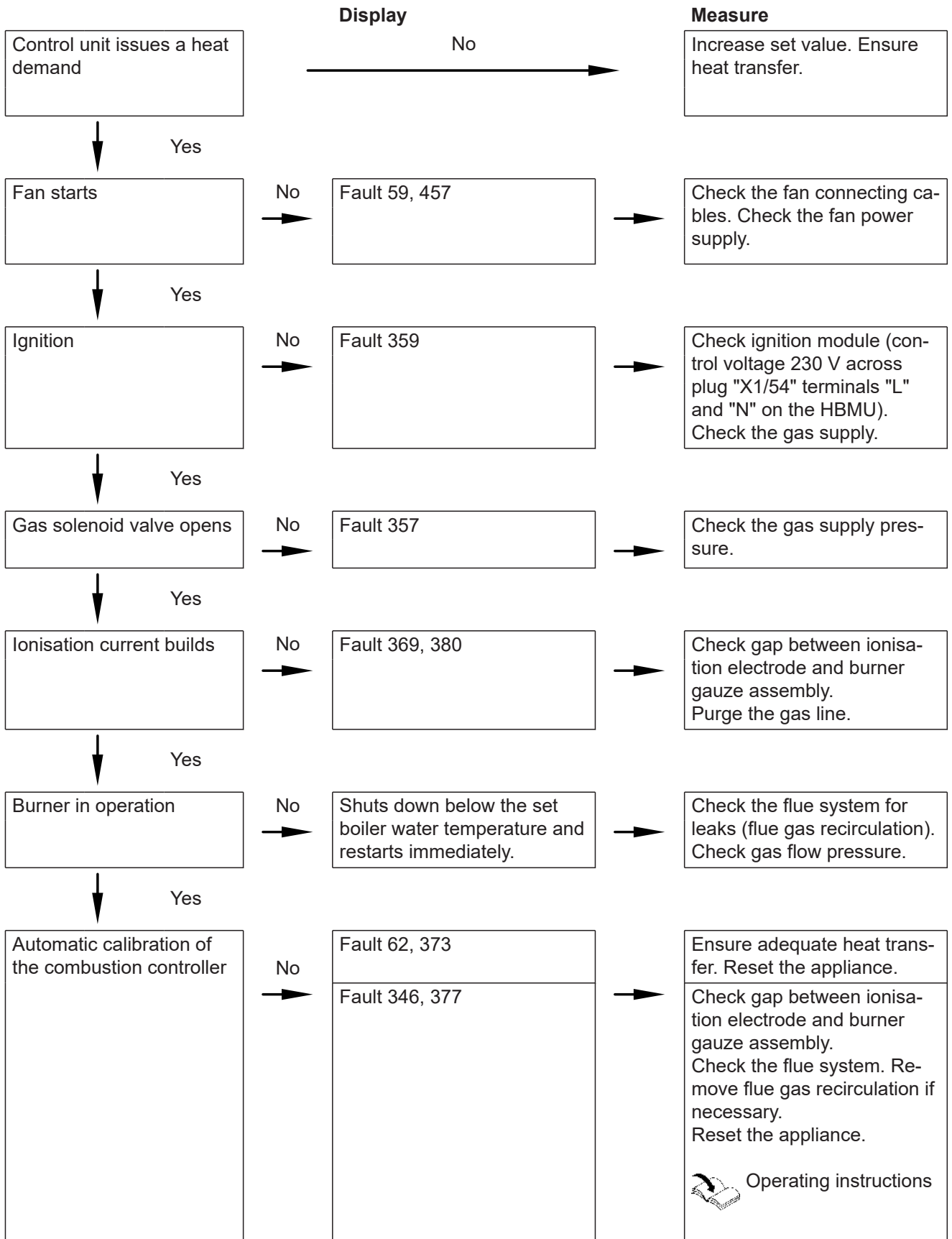

For further details regarding faults, see chapter "Troubleshooting".



Setting the maximum heating output

A limit can be set on the maximum heating output for **heating mode**. The limit is set via the modulation range.

Note

The flow rate must be checked before the max. heating output can be adjusted. Ensure adequate heat transfer.

Tap the following buttons:

1. and **OK** simultaneously for approx. 4 s, then release.
2. Use to select "b.2" for system configuration.

3. **OK**
4. Use to select "7" for max. heating output.
5. **OK**
6. Use to set the required value in % of rated heating output. Delivered condition 100 % (100 % = "HI" on the display).
7. **OK**



Performing an actuator test

The actuator test can only be set via the software tool.



Adjusting the integral circulation pump rate

Operation of the integral circulation pump as heating circuit pump for heating circuit 1

The pump speed and consequently the pump rate are controlled subject to the outside temperature and the switching times for heating mode or reduced mode. The max. speed for heating mode can be matched to the existing heating system at the control unit.

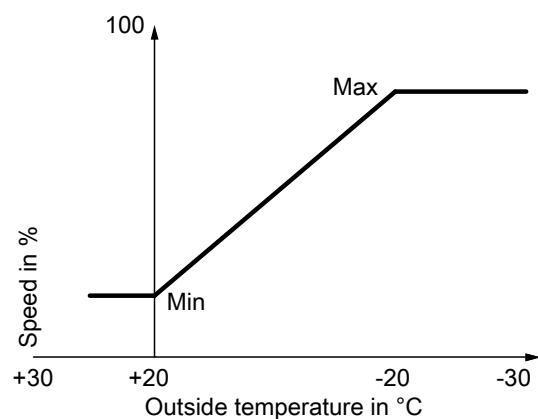

Fig. 28

Setting (%) in system configuration: See page 58.

- In the delivered condition, the minimum pump rate and the maximum pump rate are set to the following values:

Rated heating output in kW	Speed settings in the delivered condition in %	
	Min. pump rate	Max. pump rate
19	40	100
25	40	100
32	40	100

- In the following system conditions, the internal circulation pump is operated at a constant speed:
 - Constant mode



Adjusting the integral circulation pump rate (cont.)

Residual heads of the integral circulation pump 19 to 25 kW

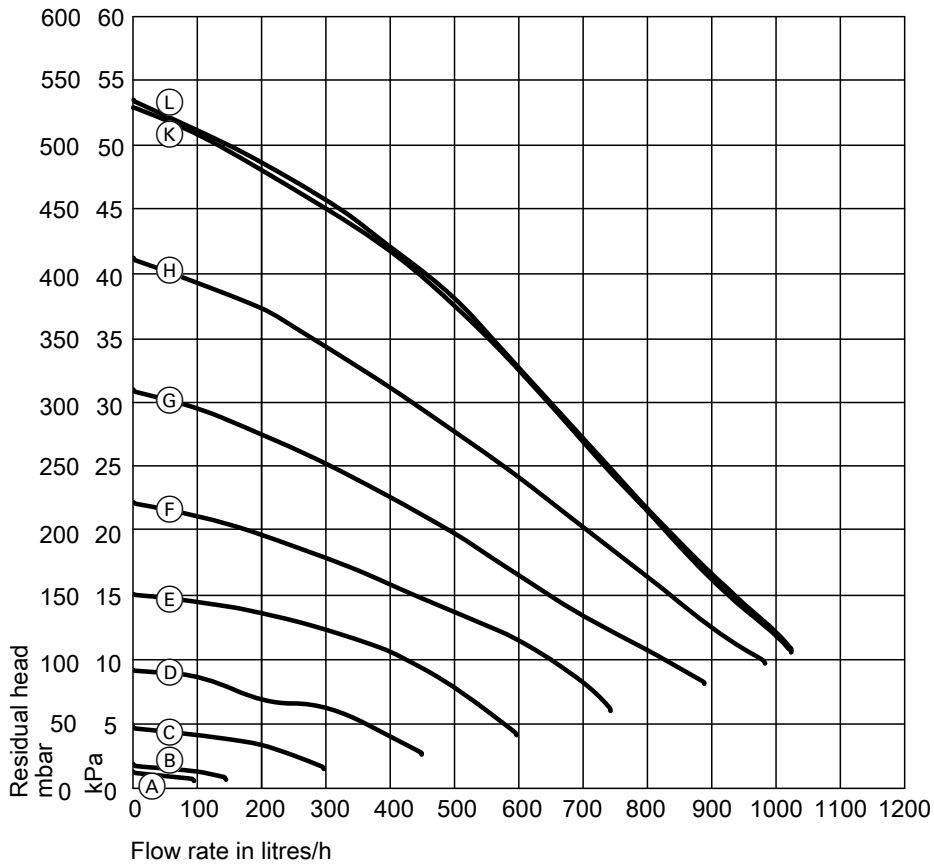

Fig. 29

Curve	Pump rate of circulation pump
(A)	0 %
(B)	10 %
(C)	20 %
(D)	30 %
(E)	40 %
(F)	50 %
(G)	60 %
(H)	70 %
(K)	80 %
(L)	90 %



Residual heads of the integral circulation pump 32 kW

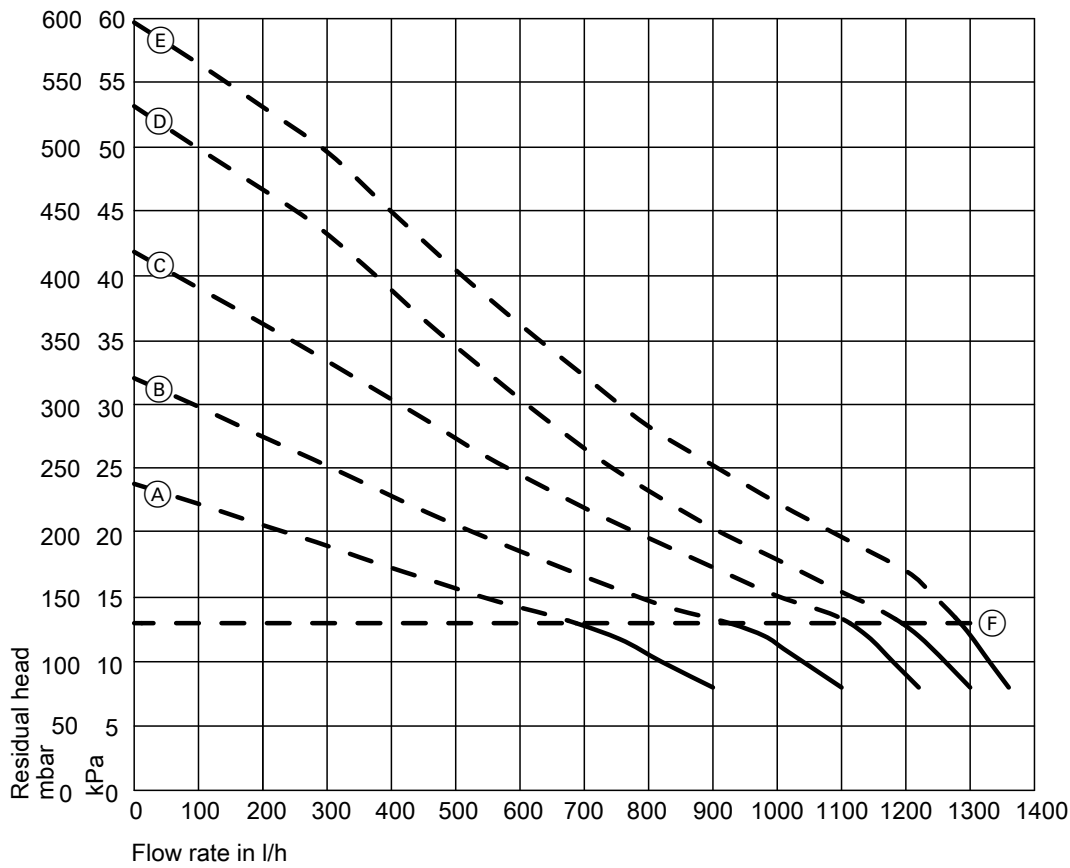

Fig. 30

(F) Upper operational limit

Curve	Pump rate of circulation pump
(A)	60 %
(B)	70 %
(C)	80 %
(D)	90 %
(E)	100 %



Checking the balanced flue system for leaks (annular gap test)

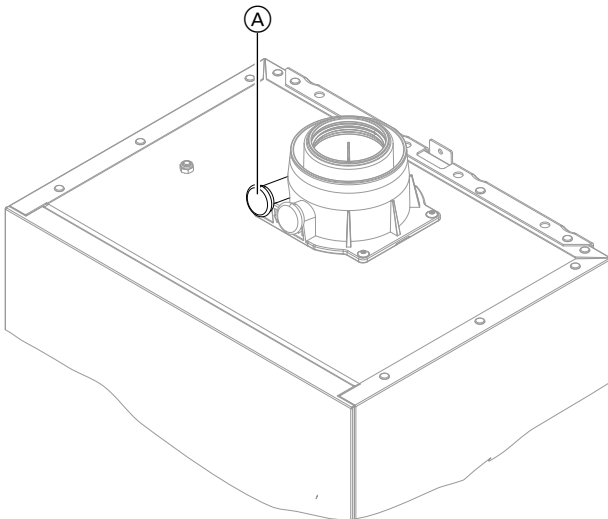

Fig. 31

Ⓐ Combustion air aperture

For balanced flue systems tested together with the heat generator, there is no requirement for a tightness test (overpressure test) during commissioning by the flue gas inspector.

In this case, we recommend that a simple tightness test is carried out during system commissioning. For this, check the CO₂ or O₂ concentration in the combustion air at the annular gap of the balanced flue pipe. If the CO₂ concentration is less than 0.2 % or the O₂ concentration is greater than 20.6 %, the flue pipe is deemed to be sufficiently gas-tight.

If actual CO₂ values are greater or O₂ values are lower, then pressure test the flue pipe with a static pressure of 200 Pa.



Please note

If the test port is not sealed, combustion air is drawn in from the room. After the tightness test, re-seal the test port with the plug.



Burner adjustment when connecting multiple flues to a shared flue system

Note

Only make this adjustment on appliances suitable for multiple connection.

For suitable Vitodens appliances, see pricelist.

When connecting several Vitodens 050-W to a common flue system:

For multiple connection, in the **commissioning assistant** use "C.5" and "C.6" to match the burner setting to the flue system. See page.

System conditions:

- Shared flue in shaft \varnothing 100 mm
- Balanced flue connection pipe from boiler to shaft, \varnothing 80/125 mm
- Minimum shaft cross-section
 - Square: 175 x 175 mm
 - Round: \varnothing 195 mm
- Height between floors min. 2.5 m
- Max. 6 boilers with the same rated heating output connected to the flue system



Removing the burner



Danger

Contact with live components can lead to serious injury from electric current. Some components on PCBs remain live even after the power supply has been switched off.

- **Do not touch** the wiring chambers (control unit and mains connections).
- When working on the appliance, isolate the system from the power supply, e.g. at a separate fuse or a main switch. Check the system is no longer live and safeguard against reconnection.
- Before working on the appliance, wait at least 4 min until the voltage has completely dropped out.

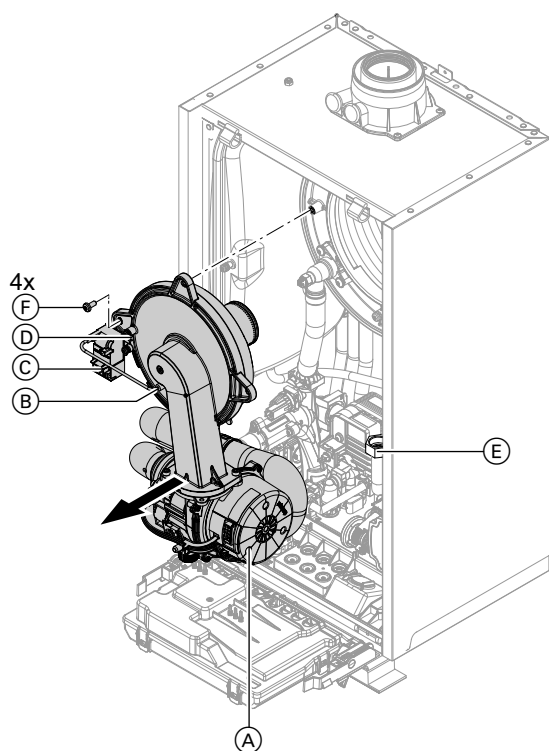

19, 25 kW

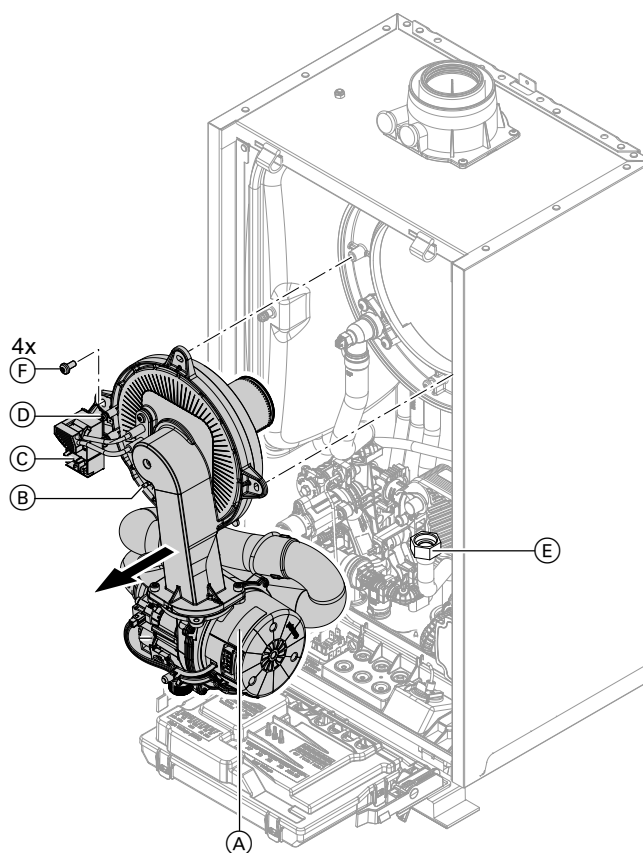

32 kW

1. Turn off the ON/OFF switch.
2. Close the gas shut-off valve and safeguard against reopening.
3. Disconnect cables and leads from:
 - Fan motor (A) (2 plugs)
 - Ionisation electrode (B)
 - Ignition unit (C)
 - Earth (D)
4. Undo gas supply pipe fitting (E).
5. Undo 4 screws (F) and remove the burner.

Note

Cover gas connection (E) so that no small parts can fall into it.



Checking the burner gasket and burner gauze assembly

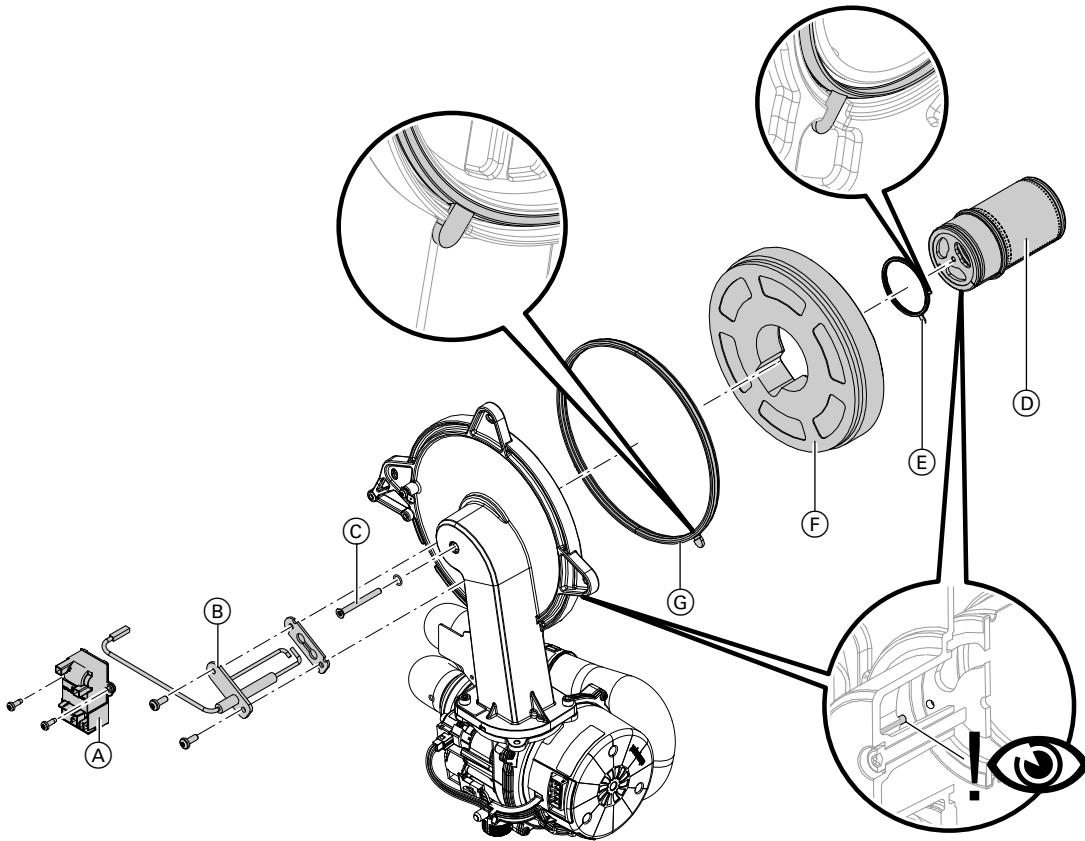

Fig. 32 19, 25 kW

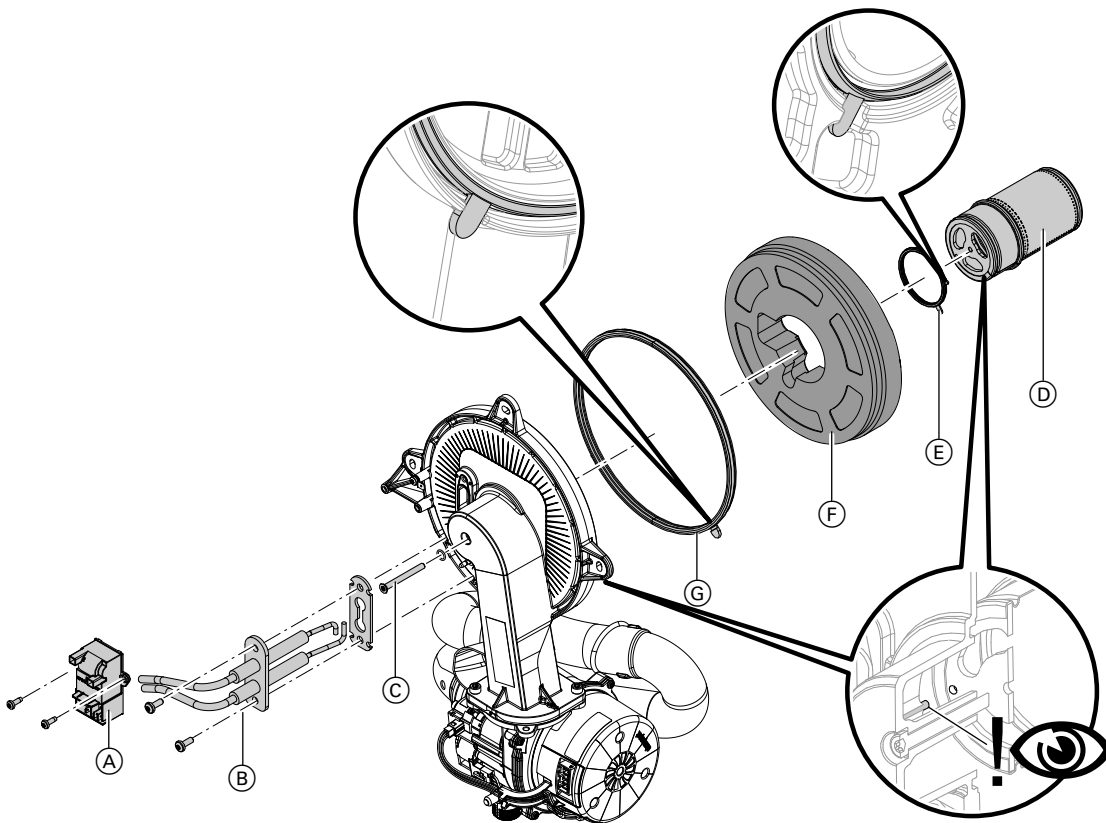

Fig. 33 32 kW



Check burner gauze assembly (D), electrodes (B), thermal insulation ring (F) and gasket (G) for damage. Only remove and replace components if they are damaged or worn.

Note

If replacing the burner gauze assembly, also replace the gauze assembly gasket and the fixing screw.

1. Disconnect the plug with ignition electrode cables from ignition unit (A).
2. Remove electrodes (B).
3. Undo Torx screw (C). Hold onto burner gauze assembly (D) when undoing the screw.
4. Remove burner gauze assembly (D) with gasket (E) and thermal insulation ring (F). Check components for damage.
5. Install new burner gasket (G). Ensure the correct installation position. Align the tab as per the diagram.
6. Insert thermal insulation ring (F) and burner gauze assembly (D) with gasket (E). Ensure the correct installation position. Align the tab as per the diagram.

7. Align the hole in burner gauze assembly (D) with the burner door pin.
Secure burner gauze assembly (D) and gasket (E) with Torx screw (C).
Tighten screws as much as necessary and ensure that the components are undamaged and function correctly throughout their service life.
Observe torque settings if a torque wrench is available.
Torque: 3.0 Nm.



Please note

Incorrect positioning of the burner gauze assembly will cause damage to the burner door.
Insert the burner door pin into the hole in the burner gauze assembly. See chapter **"Installing the burner gauze assembly"**, page

8. Check thermal insulation ring (F) for firm seating.
9. Fit electrodes (B). Check clearances; see following chapter.
Tighten screws as much as necessary and ensure that the components are undamaged and function correctly throughout their service life.
Observe torque settings if a torque wrench is available.
Torque: 4.5 Nm.





Checking the burner gasket and burner gauze... (cont.)

Installing the burner gauze assembly

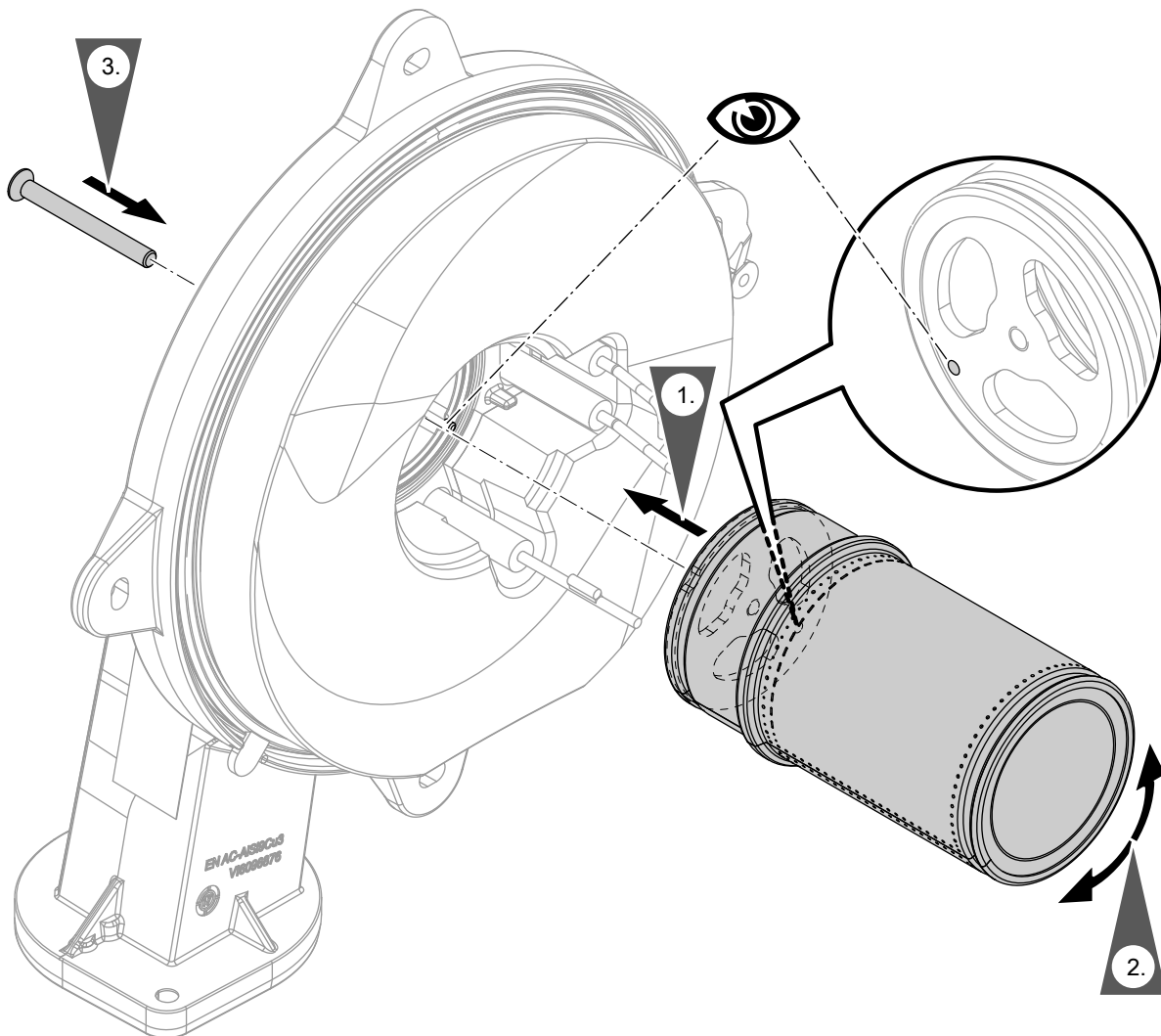

Fig. 34



Checking and adjusting the ignition and ionisation electrodes

Burners 19, 25 kW

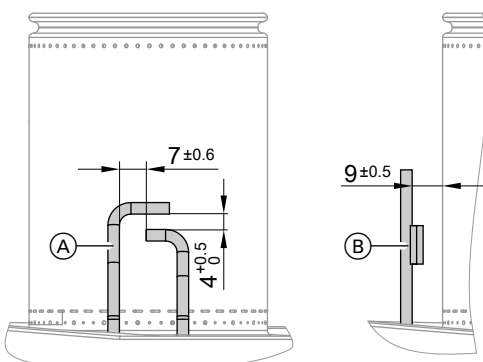

Fig. 35

- (A) Ignition electrodes
- (B) Ionisation electrode



Checking and adjusting the ignition and... (cont.)

1. Check the electrodes for wear and contamination.
2. Clean the electrodes with a small brush (not a wire brush) or sandpaper.
3. Check the electrode gaps. If the gaps are not as specified or the electrodes are damaged, replace the electrodes and gaskets and adjust them as required.
Tighten screws as much as necessary and ensure that the components are undamaged and function correctly throughout their service life.
Observe torque settings if a torque wrench is available.
Tighten the electrode fixing screws to a torque of 4.5 Nm.

Burners 32 kW

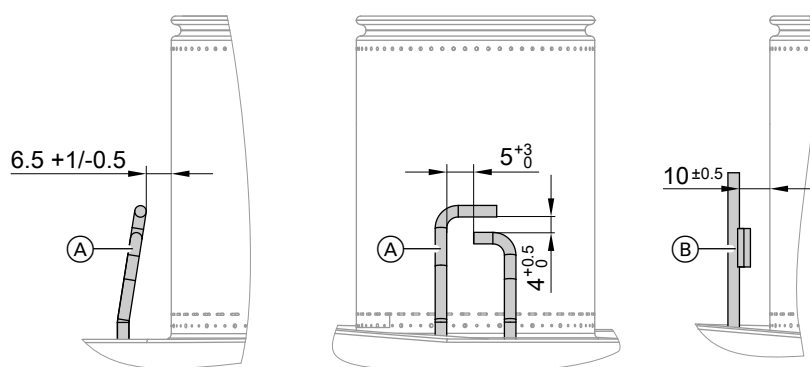

Fig. 36

- (A) Ignition electrodes
- (B) Ionisation electrode

1. Check the electrodes for wear and contamination.
2. Clean the electrodes with a small brush (not a wire brush) or sandpaper.
3. Check the electrode gaps. If the gaps are not as specified or the electrodes are damaged, replace the electrodes and gaskets and adjust them as required.
Tighten screws as much as necessary and ensure that the components are undamaged and function correctly throughout their service life.
Observe torque settings if a torque wrench is available.
Tighten the electrode fixing screws to a torque of 4.5 Nm.



Checking the back draught safety devices

Only for multiple connection to a shared flue system.



Checking the back draught safety devices (cont.)

Back draught safety device in the mixing shaft of the burner

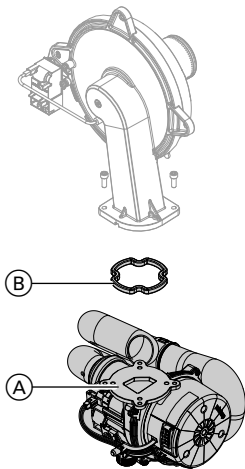

Fig. 37

1. Undo 2 screws and remove fan (A).
2. Remove back draught safety device (B).
3. Check the damper and gasket for dirt and damage. Replace if necessary.
4. Refit back draught safety device (B).

Note

Observe correct installation position!

5. Refit fan (A) and secure with 2 screws. Tighten screws as tightly as necessary and ensure that the components are undamaged and are functioning correctly throughout service life. Observe torque settings if a torque wrench is available.
Torque: 4.0 Nm

Back draught safety device in the flue gas connection

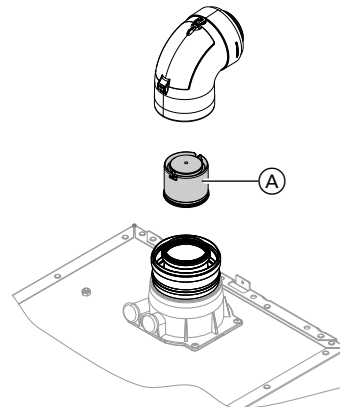

Fig. 38

1. Remove the balanced flue system.

Note

If the balanced flue system cannot be removed, clean and check the back draught safety device via the inspection cover.

2. Check back draught safety device (A) for dirt, ease of movement and function.
3. Refit the balanced flue system.
4. Pour a small amount of water through the inspection port to ensure the back draught safety device is working.



Cleaning the heating surfaces

- ! **Please note**
Scratches to the surfaces of the heat exchanger that come into contact with hot gas can result in corrosion damage. Brushing can cause deposits to become lodged in the gaps between the coils. **Do not use brushes to clean the heating surfaces.**

- ! **Please note**
Prevent damage due to cleaning water. Cover electronic components with suitable watertight material.

Note

Discolouration on the heat exchanger surface is a normal sign of use. It has no bearing on the function or service life of the heat exchanger. The use of chemical cleaning agents is not required.



Cleaning the heating surfaces (cont.)

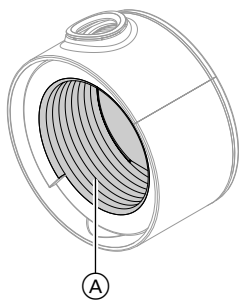

Fig. 39

1. Use a vacuum cleaner to remove combustion residues from heating surface (A) of the heat exchanger.
2. Flush heating surface (A) with water.
3. Check condensate drain. Clean the trap: See the following chapter.
4. Check the thermal insulation mat (if fitted) in the heat exchanger for damage; replace if necessary.



Checking the condensate drain and cleaning the trap

! **Please note**
Prevent damage due to condensate.
Cover electronic components with suitable watertight material.

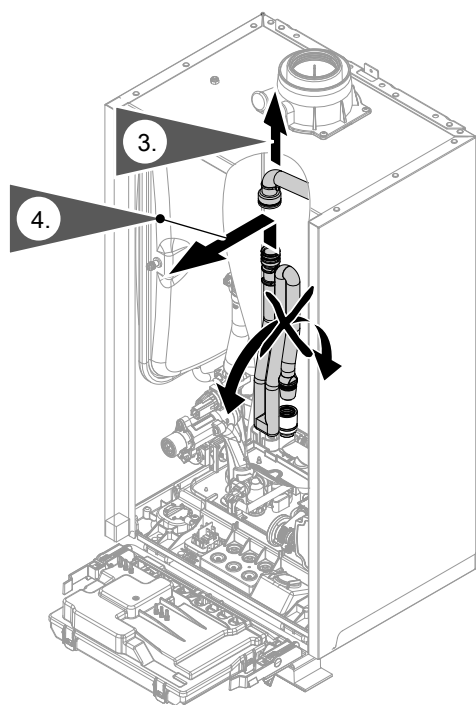

Fig. 40

1. Pivot the HBMU heat management unit forwards.
2. Cover electronic components with suitable watertight material.

3. Remove the black supply hose.
4. Pull trap upwards out of the drain hose.
5. Hold trap as straight as possible and remove. Ensure that no condensate runs out.
6. Clean the trap.
7. Fill the trap with water and refit it on the drain hose.

! **Please note**
If the trap is not filled with water, flue gas can escape.
Only start the appliance when the trap has been filled.
Check that the trap is seated correctly.

8. Refit supply hose.
9. **!** **Danger**
Risk of electric shock from escaping condensate
Check the connections for leaks and check that the trap is seated correctly.

Note
Route the drain hose without any bends and with a constant fall.

Multi boiler system:
Clean the trap in the flue gas collector as well.



Installing the burner

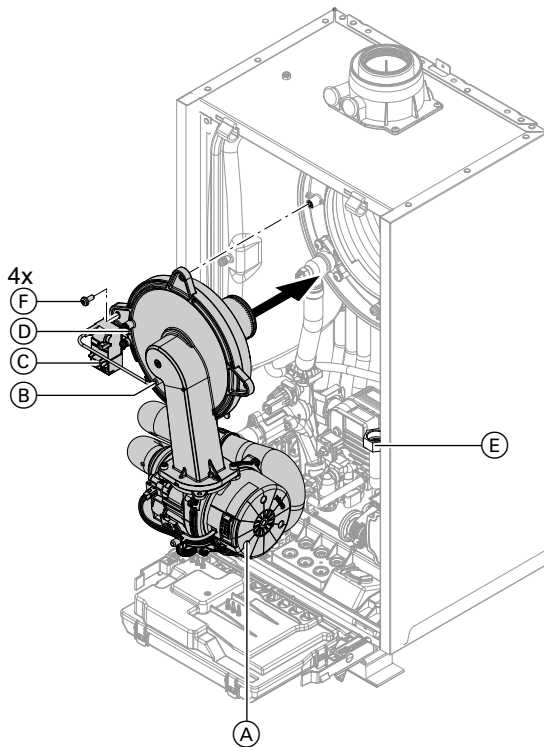

Fig. 41

1. Insert the burner. Tighten screws (F) diagonally. Tighten screws as tightly as necessary and ensure that the components are undamaged and are functioning correctly throughout service life. Observe torque settings if a torque wrench is available.
Torque: 6.5 Nm
2. Fit gas connection pipe (E) with a new gasket. Tighten screws as tightly as necessary and ensure that the components are undamaged and are functioning correctly throughout service life. Observe torque settings if a torque wrench is available.
Check for gas tightness to BSI 6891.
Torque: 30 Nm
3. Check the gas connections for leaks.

⚠ Danger
Escaping gas leads to a risk of explosion. Check all fittings for gas tightness. In the case of wall mounted appliances, also check the gas shut-off valve fitting on the underside.
4. Connect the cables/leads:
 - Fan motor (A) (2 plugs)
 - Ionisation electrode (B)
 - Ignition unit (C)
 - Earth (D)



Checking the neutralising system (if installed)



Checking the flow limiter (only for gas condensing combi boiler)

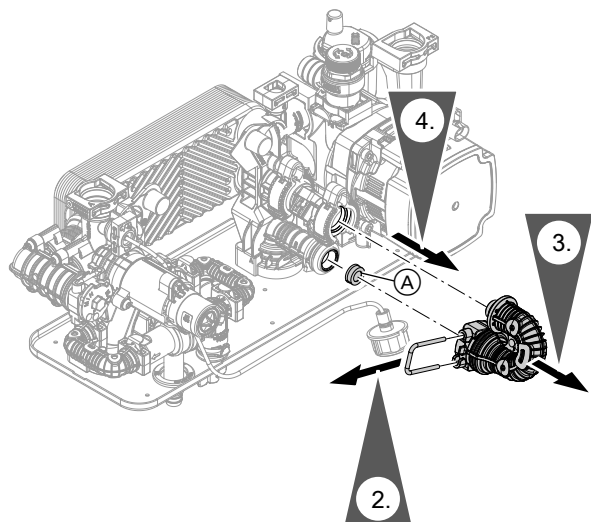

Fig. 42

1. Drain the boiler on the DHW side.
2. Remove the spring clip.
3. Remove the DHW flow sensor.
4. Check flow limiter (A). Replace if scaled or damaged. Reinsert.

5. Fit the DHW flow sensor with new gaskets.



Danger

Risk of electric shock from escaping heating water or DHW
Check all water side connections for leaks.

Flow limiter

Appliance type	Flow rate l/min	Colour
B0KA-25 (GB)	10	Red
B0KA-30 (GB)	12	Pink
B0KA-30-M (GB)	12	Pink
B0KA-35 (GB)	14	Blue



Checking the expansion vessel and system pressure

Note

The expansion vessel can lose some of its charge pressure over time. When the boiler heats up, the pressure rises to 2 or 3 bar (0.2 or 0.3 MPa). The safety valve may also respond and discharge the excess pressure.

Therefore check the expansion vessel pre-charge pressure annually.

Check whether the installed expansion vessel is adequate for the system water volume.
Carry out this test on a cold system.

1. Drain the system until "0" is shown on the display.

Note

For pressure indicator on home screen, press  repeatedly until the pressure gauge symbol appears.

2. If the pre-charge pressure of the expansion vessel is lower than the static system pressure: Top up with nitrogen at the valve of the diaphragm expansion vessel until the pre-charge pressure is 0.1 to 0.2 bar (10 to 20 kPa) higher than the static system pressure.



Checking the expansion vessel and system... (cont.)

- Top up with water until the charge pressure of the cooled system is at least 1.0 bar (0.1 MPa), and is 0.1 to 0.2 bar (10 to 20 kPa) higher than the pre-charge pressure of the expansion vessel.
Permiss. operating pressure: 3 bar (0.3 MPa)

Note

The expansion vessel is supplied from the factory with a pre-charge pressure of 0.7 bar.

Do not allow the pre-charge pressure to fall below this value (boiling noises). This also applies to single floor heating systems or attic heating centres (no static pressure).

Top up with water until the charge pressure is 0.1 to 0.2 bar above the pre-charge pressure.



Checking the safety valve function



Checking the electrical connections for firm seating



Danger

Contact with live components can lead to serious injury from electric current. Some components on PCBs remain live even after the power supply has been switched off.

- **Do not touch** the wiring chambers (control unit and mains connections).
- When working on the appliance, isolate the system from the power supply, e.g. at a separate MCB/fuse or a mains isolator. Check the system is no longer live and safeguard against reconnection.
- Prior to working on the appliance, wait at least 4 min until the voltage has completely dropped out.



Checking all gas equipment for leaks at operating pressure



Danger

Escaping gas leads to a risk of explosion. Check gas equipment (including inside the appliance) for leaks.

Note

Only use suitable and approved leak detection agents (EN 14291) and devices for the tightness test. Leak detection agents with unsuitable constituents (e.g. nitrides, sulphides) can cause material damage. Remove residues of the leak detection agent after testing.



Fitting the front panel

See page 31.



The electronic combustion controller automatically ensures optimum combustion quality. During commissioning/maintenance, only the combustion values need to be checked. To do this, test the CO content and CO₂ or O₂ content, and record these in the report on page 104.

Note

To prevent operating faults and damage, operate the appliance with uncontaminated combustion air.

Permissible CO content

The CO content must be < 1000 ppm for all gas types.

Permissible CO₂ or O₂ content

Operation with natural gas

Rated heating output (kW)	CO ₂ content (%)		O ₂ content (%)	
	Upper heating output	Lower heating output	Upper heating output	Lower heating output
19	7.3 to 10.5	7.3 to 10.5	2.1 to 8.4	2.1 to 8.4
25	7.3 to 10.5	7.3 to 10.5	2.1 to 8.4	2.1 to 8.4

Operation with LPG

Rated heating output (kW)	CO ₂ content (%)		O ₂ content (%)	
	Upper heating output	Lower heating output	Upper heating output	Lower heating output
19	8.4 to 11.8	8.4 to 11.8	3.1 to 8.1	3.1 to 8.1
25	8.4 to 11.8	8.4 to 11.8	3.1 to 8.1	3.1 to 8.1

If the actual CO, CO₂ or O₂ values lie outside their respective ranges, proceed as follows:

- Check the balanced flue system for leaks: See page 45.
- Check the ionisation electrode and connecting cable: See page 49.

Note

During commissioning, the combustion controller carries out an automatic calibration. Allow approx. 50 s after the burner has started before testing the emissions.

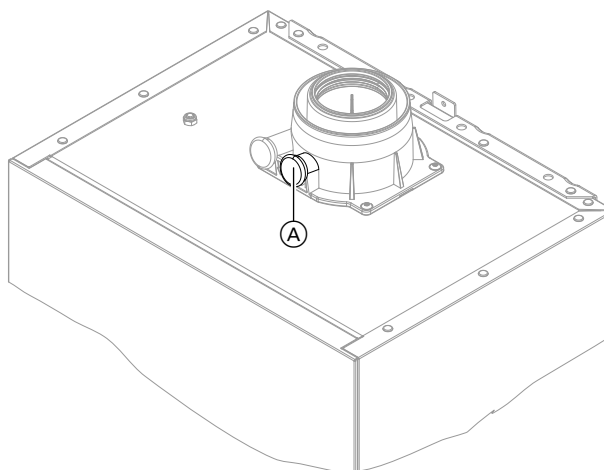

Fig. 43

1. Connect a flue gas analyser at flue gas port (A) on the boiler flue connection.
2. Open the gas shut-off valve. Start the boiler. Create a heat demand.
3. Adjust the lower heating output. See the following chapter.
4. Check the CO₂ content. If the actual value deviates from the permissible ranges, implement steps listed above.
5. Enter the actual value into the report.
6. Adjust the upper heating output. See the following chapter.



Checking the combustion quality (cont.)

7. Check the CO₂ content. If the actual value deviates from the permissible ranges by more than 1 %, implement steps listed above.
8. Enter the actual value into the report.
9. Re-seal test port (A).



Danger

Escaping flue gas can damage your health. Check test port (A) for leaks.

Regulating to the upper/lower heating output

Note

Ensure adequate heat transfer.

Tap the following buttons:

1. and **OK** simultaneously for approx. 4 s, then release.
2. Use to select "**b.6**" for the upper/lower heating output.
3. **OK**
4. Use to set the value.
 "OF" - off
 "1" - Min. heating output
 "2" - Max. heating output
5. **OK**
 Burner is operating with correspondingly adjusted heating output.



Checking the flue system for unrestricted flow and leaks



Matching the control unit to the heating system

The control unit must be matched to the system equipment level.
 Set the parameters according to the accessories fitted:



Accessory installation instructions



Adjusting the heating curve

Tap the following buttons:

- 1.
2. Use to select "**P.3**" for the heating curve.
3. **OK**
4. Use to adjust the slope.
5. **OK**
6. Use to adjust the level.
7. **OK** to confirm



Instructing the system user

The system installer should hand the operating instructions to the system user and instruct the user in operating the system.

This includes all components installed as accessories, e.g. remote control units. In addition, the system installer must make the user aware of the required maintenance work.

DHW hygiene

For optimum DHW hygiene, avoid DHW temperatures that are < 50 °C. For larger systems and systems with low water exchange, the temperature should not drop below < 60 °C.

Inform the system user what DHW temperatures should be set and the risks associated with having a higher outlet temperature at the draw-off points.

System configuration (parameters)



Calling up parameters

Note

The display and setting of some parameters is dependent on:

- Heat generator
- Connected accessories and the functions associated with them

Tap the following buttons:

1.  and **OK** simultaneously for approx. 4 s, then release.
2. Use  to select "b.2" for system configuration.

3. **OK**

4. Use  to select the parameter for adjustment. See tables below.

5. **OK**

6.  for the required value.

7. **OK**

Note

Further parameters can be called up via the software tool.

Parameters

Note

Parameter values in **bold** are factory settings.

3 Scald protection

The adjustable DHW temperature is limited to a maximum value.

Value	Meaning
0	Scald protection off  Danger Risk of injury due to higher DHW temperature. Inform the system user of the risk from the higher outlet temperature at the draw-off points.
1	Scald protection on (max. DHW temperature 60 °C) Note Even with the scald protection switched on, higher outlet temperatures may occur at the draw-off points in the following cases: <ul style="list-style-type: none">▪ While the appliance is being calibrated

4 Max. speed of speed-controlled primary/heating circuit pump in standard mode, heating circuit 1

Maximum speed of the internal circulation pump in heating mode with standard room temperature

Value	Meaning
...	Delivered condition specified by settings specific to the heat generator
0 to 100	Maximum speed adjustable from 0 to 100 %

Parameters (cont.)**6 Minimum heating output**

A limit can be set on the minimum heating output for heating mode.

Value	Meaning
...	Delivered condition specified by settings specific to the appliance
0 to 100	Adjustable from 0 to 100 %

7 Maximum heating output

A limit can be set on the maximum heating output for heating mode.

Value	Meaning
100	Heating output in the delivered condition 100 %
0 to 100	Adjustable from 0 to 100 %

8 Maximum flow temperature limit, heating circuit 1

Maximum flow temperature limit for the heating circuit

Value	Meaning
No setting!	Maximum limit in the delivered condition 82 °C Setting range limited by heat generator-specific parameters

Energy saving functions (setting only via software tool)**2426.1 Weather-compensated heating circuit pump logic function (only for weather-compensated control units).**

No setting!

Value	Explanations
	If the outside temperature is above the threshold value (the selected set room temperature plus the hysteresis in K), the heating circuit pump is switched off. If the outside temperature is below the threshold value (selected set room temperature plus hysteresis in K), the heating circuit pump is switched on.

2426.2 Room temperature-dependent heating circuit pump logic (only for weather-compensated control units with room temperature hook-up).

Only activate this function for the heating circuit with mixer or if there is only one direct heating circuit in the system.

Value	Meaning
No setting!	If the actual room temperature is above the threshold value (selected set room temperature plus hysteresis in K), the heating circuit pump is switched off. If the actual room temperature is below the threshold value (selected set room temperature plus hysteresis in K), the heating circuit pump is switched on.

1667.0 Pump activation, heating circuit pump in standby mode (via software tool)

Operating mode, heating circuit pump.

Value	Meaning
0	- "Standby mode" = permanently switched off
1 to 24	- "Standby mode" switched on 1 to 24 times a day for 10 min in constant mode and for 50 min in weather-compensated mode.

Service menu

Calling up the service menu

Press the following buttons:

1.  and **OK** simultaneously for approx. 4 s.
2. Select the required menu section (e.g. **"b.1"** Connect with software tool).

Note

Press  to return to the service menu.

Note

Not all menu sections will be available, depending on the system equipment level.

Service menu overview

Service	
Er Active messages	
b.1 Connect with software tool.	
b.2 System configuration	
b.3 Diagnostics	
	d.1 Outside temperature
	d.2 Heat generator flow temperature
	d.3 Primary pump speed %
	d.4 Flue gas temperature
	d.5 Burner hours run
	d.6 Burner output
	d.7 3-way valve position
	0 = Heating
	1 = Middle position (if installed)
	2 = DHW
	d.8 Serial number of heat generator
	d.9 Heating circuit 1 flow temperature
b.4 Message history	
b.5 Commissioning assistant	
b.6 Start upper/lower heating output for test mode.	

Diagnosis

Exiting the service menu

Press the following buttons:

 multiple times.

Note

The system exits the service menu automatically after 30 min.

Diagnosis

Checking operating data



Operating data can be checked in various areas. See **"Diagnosis"** in the service menu overview.

Operating data on heating circuits with mixer can only be called up if such components are installed in the system.

Diagnosis (cont.)**Note**

If a called up sensor is faulty, "- - -" appears on the display.

Calling up operating data**Tap the following buttons:**

1.  and **OK** simultaneously for approx. 4 s, then release.
2. Use  to select "**b.3**" for diagnostics.

3. **OK**

4. Use  to select the required entry.

Note

Use  to view "**d.8**" serial number of heat generator in sections.

5. **OK**

Fault display on the programming unit



The display shows "△" in the event of a fault.

Note

If a central fault message facility is connected, this is switched on.

Calling up fault messages

Tap the following buttons:

1.  and **OK** simultaneously for approx. 4 s, then release.
2.  for "Er" message list
3. **OK**
4.  to select fault entry "E.1, E.2...".
5. **OK**
6. Fault code is displayed.

Note

If the fault code has 3 digits, the first two digits are shown first and then the last digit.



Acknowledging the fault display

Calling up the fault in the "Er" menu automatically acknowledges the fault display.

Calling up acknowledged fault messages

Tap the following buttons:





1. 

2.  to select "Er".
3. **OK**
4.  to call up fault entry "E.1 to E.5".
5. **OK**
6.  to display the fault code.

Reading out fault messages from the fault memory (message history)

The 5 most recent faults (including those remedied) are saved and can be called up. Faults are sorted by date.

Tap the following buttons:

1.  and **OK** simultaneously for approx. 4 s, then release.
2.  for "b.4" Message history
3. **OK**
4. Use  to select fault entry "E.1, E.2... or E.5".
For messages, see chapter "Further messages".
5. **OK**
6.  for the required message
7. **OK**

Overview of electronics modules

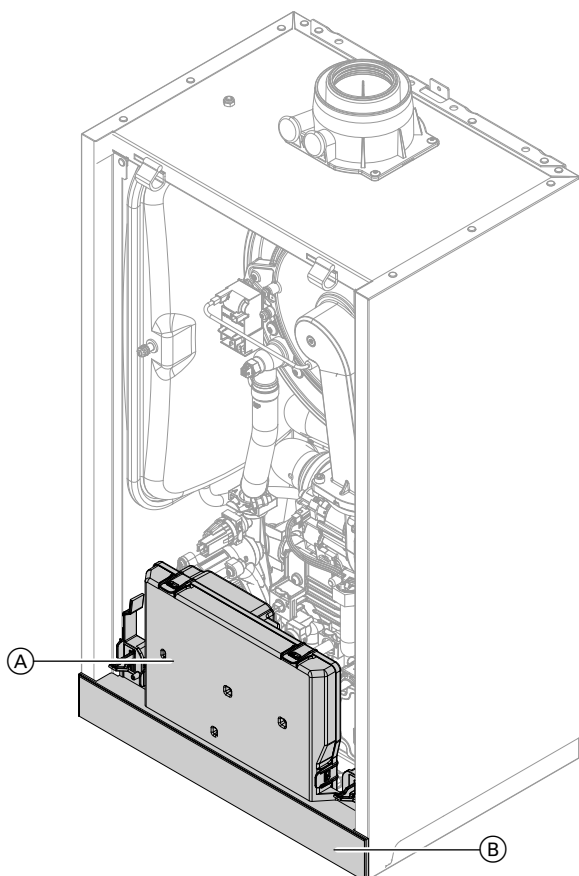

Fig. 44

- (A) HBMU heat management unit
- (B) Programming unit with TCU 100 communication module

Fault messages

Note

For diagnostics and troubleshooting, see chapter "Repairs".

Fault messages dependent on appliance equipment level

7

System characteristics

No DHW heating

Cause

Lead break, cylinder temperature sensor

Measures

- Check DHW setting in the commissioning assistant and correct if necessary.
 - Check the cylinder temperature sensor (terminal S.T.S).
 - Measure the voltage at the sensor input on the HBMU heat management unit. Set value: 3.3 V_{DC} with sensor disconnected
- Replace faulty component if necessary.

Fault messages (cont.)

8

System characteristics

No DHW heating

Cause

Short circuit, cylinder temperature sensor

Measures

Check the cylinder temperature sensor (terminal S.T.S).

Replace faulty component if necessary.

13

System characteristics

Regulates as if the outside temperature were 0 °C.

Cause

Lead break, outside temperature sensor

Measures

- Check operating mode setting in commissioning assistant and remedy if necessary.
 - Check the outside temperature sensor and connection to sensor (terminal O.T.S).
 - Measure the voltage at the sensor input on the HBMU heat management unit. Set value: 3.3 V_{DC} with sensor disconnected
- Replace faulty component if necessary.

14

System characteristics

Regulates as if the outside temperature were 0 °C.

Cause

Short circuit, outside temperature sensor

Measures

Check the outside temperature sensor and connection to sensor (terminal O.T.S). Replace faulty components if necessary.

49

System characteristics

Burner in a fault state

Cause

Lead break, flue gas temperature sensor

Measures

Check flue gas temperature sensor.
Reset the appliance.

50

System characteristics

Burner in a fault state

Cause

Short circuit, flue gas temperature sensor

Measures

Check flue gas temperature sensor.
Reset the appliance.

Fault messages (cont.)

57

System characteristics

Normal operation without room influence

Cause

Lead break, room temperature sensor

Measures

- Check commissioning setting of remote control.
- Check plug and cable of external room temperature sensor, heating circuit.
- If no external room temperature sensor installed, replace programming unit.

58

System characteristics

Normal operation without room influence

Cause

Short circuit, room temperature sensor

Measures

Check plug and cable of external room temperature sensor, heating circuit.
If no external room temperature sensor installed, replace programming unit.

59

System characteristics

Burner locked out, boiler circuit pump off. No central heating, no DHW heating

Cause

Power supply, undervoltage

Measures

Check mains voltage.
If voltage is correct and the fault occurs repeatedly, replace the fan unit.

62

System characteristics

Burner in a fault state

Cause

High limit safety cut-out has responded.

Measures

- Check heating system fill level.
- Check pre-charge pressure in diaphragm expansion vessel. Adjust to required system pressure.

- Check whether flow rate is sufficient (circulation pump).
- Check function of 3-way diverter valve. Vent the system.
Reset the appliance.

63

System characteristics

Burner in a fault state

Cause

Flue gas temperature limiter has responded.

Measures

- Check heating system fill level.
- Check pre-charge pressure in diaphragm expansion vessel. Adjust to required system pressure.
- Check whether flow rate is sufficient (circulation pump).
- Check function of 3-way diverter valve.

Fault messages (cont.)

Vent the system.

Reset the appliance once the flue system has cooled down.

64

System characteristics

Normal operation; burner restarts.

Cause

Flame loss in the stabilisation or operating phase.

Measures

- Check gas supply (gas pressure and gas flow switch).
- Check balanced flue system for flue gas recirculation.
- Check ionisation electrode (replace if necessary): Check the distance of the electrode to the burner gauze assembly and its contamination level.

67

System characteristics

Burner in a fault state

Cause

Ionisation current lies outside the permissible range

Measures

Check gas supply (gas pressure and gas flow switch), check gas solenoid valve and inlet strainer.

Check ionisation electrode for the following:

- Clearance to burner gauze assembly
- Check electrode/burner gauze assembly for contamination.

If specified measures do not help, replace fan unit. Reset the appliance.

68

System characteristics

Burner in a fault state

Cause

Flame signal is already present at burner start.

Measures

Close the gas shut-off valve. Remove connecting cable of the ionisation electrode.

Reset the appliance.

If the fault persists, replace the HBMU heat management unit. See chapter "Replacing the HBMU heat management unit".

69

System characteristics

Burner in a fault state

Cause

Ionisation current lies outside the permissible range

Fault messages (cont.)

Measures

Check ionisation electrode for the following:

- Check whether insulation block is touching electrode ceramic.
- Check gas solenoid valve: In the service menu under "b.6", set the burner output to the lower heating output for approx. 4 min. If the fault occurs, replace the HBMU heat management unit. See chapter "Replacing the HBMU heat management unit".
- Change the burner output from lower to upper heating output in the service menu under "b.6". If this fault occurs during modulation, check the inlet strainer for contamination. Replace the fan unit if necessary.

70

System characteristics

Burner in a fault state

Cause

HBMU heat management unit internal fault

Measures

Replace the HBMU heat management unit. See chapter "Replacing the HBMU heat management unit".

71

System characteristics

Burner in a fault state

Cause

Fan speed too low

Measures

- Check fan for blockage.
- Check setting for gas type and flue system. Reset the appliance.

72

System characteristics

Burner in a fault state

Cause

Fan idle state not reached

Measures

- Reset the appliance.
- If the fault occurs repeatedly, replace the fan unit.

73

System characteristics

Burner in a fault state

Cause

Internal communication error

Measures

- Reset the appliance.
- If the fault occurs repeatedly, replace the HBMU heat management unit. See chapter "Replacing the HBMU heat management unit".

74

System characteristics

Burner locked out.
Internal circulation pump off. No central heating and no DHW heating

Cause

System pressure too low

Measures

Top up with water.

Vent the system.

If the fault reoccurs:

- Check system pressure sensor with external pressure gauge.
- Check diaphragm expansion vessel pre-charge pressure.
- Check settings for set system pressure and range.

75

System characteristics

Burner in a fault state

Cause

No flow rate

Measures

- Open BDF valves.
- Top up with water.
- Replace the flow sensor (if installed). Replace the pump.

77

System characteristics

Burner in a fault state

Cause

HBMU heat management unit data memory

Measures

Reset the appliance.

If the fault reoccurs, replace the HBMU heat management unit: See chapter "Replacing the HBMU heat management unit".

78

System characteristics

Normal operation

Cause

Communication between heat management unit and programming unit disrupted/interrupted.

Measures

Check cables and plug-in connections between central control unit and programming unit.
Check cables for correct routing/position.

87

System characteristics

Burner locked out. Internal pump off. No central heating and no DHW heating.

Cause

System pressure too high

Measures

- Check the system pressure. Correct if necessary.
- Check diaphragm expansion vessel pre-charge pressure.
- Check whether BDF valves are open.
- Check system pressure sensor with external pressure gauge.

Fault messages (cont.)

89

System characteristics

No central heating and no DHW heating

Cause

Internal circulation pump blocked

Measures

Check circulation pump. Replace if necessary.

95

System characteristics

Normal operation

Cause

OpenTherm remote control not connected

Measures

- Check connection to the OpenTherm remote control.
- If OpenTherm is not required, set "C.7" in the commissioning assistant to a value not equal to 14.

102

System characteristics

No internet connection

Cause

Communication between heat management unit and WiFi communication module disrupted/interrupted.

Measures

Check the cables and plug-in connections between the HBMU heat management unit and the WiFi communication module.

103

System characteristics

Normal operation

Cause

Internal communication error, HMI programming unit

Measures

Check the cables and plug-in connections between the central control unit and the programming unit.

104

System characteristics

Depending on configuration of EM-EA1 extension (DIO electronics module)

Cause

External fault message input active

Measures

Check connected external appliance.

142

System characteristics

Burner in a fault state

Cause

Communication restriction on CAN bus. INR

Measures

- Check the fan unit for correct function. For this, check the stepper motor of the fan unit (reference run with mains ON).
- If the fault still persists, check the plug-in connections and cables of the CAN bus.
- Check further CAN bus subscribers. If fault occurs repeatedly, replace fan unit.

161

System characteristics

Burner in a fault state

Cause

HBMU heat management unit data memory access fault

Measures

Reset the appliance.
If the fault occurs repeatedly, replace the HBMU heat management unit. See chapter "Replacing the HBMU heat management unit".

163

System characteristics

Burner in a fault state

Cause

Checksum error, data memory access, HBMU heat management unit

Measures

Reset the appliance.
If the fault occurs repeatedly, replace the HBMU heat management unit. See chapter "Replacing the HBMU heat management unit".

182

System characteristics

No DHW heating

Cause

Short circuit, outlet temperature sensor (if installed)

Measures

Check outlet temperature sensor (plug X7, cores 3 and 4). Measure sensor input on HBMU heat management unit. Set value: 3.3 V– with sensor disconnected

183

System characteristics

No DHW heating

Cause

Lead break, outlet temperature sensor (if installed)

Measures

Check outlet temperature sensor (plug X7, cores 3 and 4).

184

System characteristics

Burner in a fault state

Fault messages (cont.)

Cause

Short circuit, flow temperature sensor/high limit safety cut-out

Check sensor lead. Replace faulty component if necessary.
Reset the appliance.

Measures

Check the flow temperature sensor/high limit safety cut-out.

185

System characteristics

Burner in a fault state

Measures

Check the flow temperature sensor/high limit safety cut-out.
Check sensor lead. Replace faulty component if required.
Reset the appliance.

Cause

Lead break, flow temperature sensor/high limit safety cut-out

299

System characteristics

Date/time wrong

Measures

Check time and date and set if necessary.

Cause

Real-time clock fault

Note

The setting can be performed via the software tool or commissioning assistant.

346

System characteristics

Burner in a fault state

- Check ionisation electrode for contamination.
- Check the flue system. Remove flue gas recirculation if necessary.
- Check the condensate drain (condensate backup). Reset the appliance.

Cause

Ionisation current calibration error

Measures

- Check the gas supply pressure.
- Check gas solenoid valve inlet strainer for contamination.

347

System characteristics

Burner in a fault state

Measures

Remove flue gas recirculation. Check entire flue gas path for the following:

- Flue gas back pressure caused by water pocket (if flue system fall is insufficient), constriction, blockage.
- Repair flue system if necessary.
- Reset the appliance.

Cause

Flue gas recirculation

348

System characteristics

Burner in a fault state

Cause

Gas modulation valve

Measures

If several heat generators are connected to a common flue system: Check whether "**Multiple connection**" is set in the commissioning assistant.
Check the flue system for unrestricted flow.
If fault remains, replace gas fan unit.

349

System characteristics

Burner in a fault state

Cause

Air mass rate flow not detected correctly in fan unit.

Measures

- Check for dust contamination in the ventilation air.
 - Check burner gauze assembly for contamination.
- Reset the appliance. If the fault occurs repeatedly, replace the gas fan unit.

350, 351

System characteristics

Burner in a fault state

Cause

Ionisation current lies outside the permissible range

Measures

Replace the HBMU heat management unit. See chapter "Replacing the HBMU heat management unit".

352

System characteristics

Burner in a fault state

Cause

Combustion CO limit exceeded

- Constrictions
- Blockages

Repair flue system if necessary.
Reset the appliance.

Measures

Check entire flue gas path for the following:

- Leaks
- Flue gas back pressure caused by water pocket (if flue system fall is insufficient)

353

System characteristics

Shutdown with restart if demand exists

Cause

Insufficient gas supply, burner output reduced

Measures

Check the gas supply.
Visually inspect gas solenoid valve inlet strainer for contamination.
Reset the appliance.

Fault messages (cont.)

354

System characteristics

Burner in a fault state

Cause

Gas modulation valve tolerance outside permissible range

Measures

Replace gas fan unit.

355

System characteristics

Burner in a fault state

Cause

Analogue signal reference check: Flame signal is already present at burner start.

Measures

Replace the HBMU heat management unit. See chapter "Replacing the HBMU heat management unit".

359

System characteristics

Burner in a fault state

Cause

No ignition spark

Measures

- Check whether the ignition electrode insulation is damaged.
- Check for a voltage of 230 V~ at the ignition module during the ignition phase. If not, replace the HBMU heat management unit.

- If 230 V~ is present at the ignition module but there is still a fault, replace the ignition module.
 - Check connecting cables and leads from ignition module and ignition electrode.
- Reset the appliance.

361

System characteristics

Burner in a fault state

Cause

Flame signal is not present or insufficient at burner start.

Measures

Check ionisation electrode and connecting cable.
Check plug-in connections for loose contacts.

Note

Deposits on the electrodes indicate foreign bodies in the combustion air. Check the installation room and flue system for causes of the deposits. For example: Laundry detergents, cleaning agents, toiletries, deposits in the ventilation air supply (chimney)

Reset the appliance.

Fault messages (cont.)

364

System characteristics

Burner in a fault state

Cause

Internal fault.

Measures

Replace the HBMU heat management unit.

365

System characteristics

Burner in a fault state

Cause

Gas valve relay contact feedback implausible (relay contact is "welded up")

Measures

Replace the HBMU heat management unit.

366, 367

System characteristics

Burner in a fault state

Cause

Gas valve power supply does not turn off.

Measures

Replace the HBMU heat management unit. See chapter "Replacing the HBMU heat management unit".

369

System characteristics

Burner in a fault state

Cause

Flame is lost immediately after flame formation (during safety time)

Measures

Check gas supply (gas pressure and gas flow switch).

Check balanced flue system for flue gas recirculation.

Check ionisation electrode for the following:

- Clearance to burner gauze assembly
- Contamination on electrode

Reset the appliance.

370

System characteristics

Burner in a fault state

Cause

Gas valve or modulation valve does not close.

Measures

Reset the appliance.
If fault occurs repeatedly, replace fan unit.

Fault messages (cont.)

371

System characteristics

Burner in a fault state

Cause

Fan speed too low

Measures

Check the fan.
Check the fan connecting cables.
Check the fan power supply.
Reset the appliance.

372

System characteristics

Burner in a fault state

Cause

Repeated flame loss during calibration

Measures

- Check ionisation electrode and connecting cable.
- Check plug-in connections for loose contacts.
- Check the flue system. Remove flue gas recirculation if necessary.
- Check system for condensate backup.
- Visually inspect gas solenoid valve inlet and inlet strainer for contamination.

Note

To prevent water damage, detach fan unit before removing the burner. Deposits on the electrodes indicate foreign bodies in the combustion air.

Check the installation room and flue system for causes of the deposits. For example laundry detergents, cleaning agents, toiletries, deposits in the ventilation air supply (chimney). If burner gauze assembly and ionisation electrode have been replaced, also clean fan unit, gas/air channel and Venturi extension. Reset the appliance.

373

System characteristics

Burner in a fault state

Cause

Heat transfer too low during calibration
Temperature limiter has shut down.

Measures

- Ensure adequate heat transfer.
 - Check circulation pump for faults, scale or blockages.
 - Check function of 3-way diverter valve. Vent the system.
 - Check function of flow sensor.
- Reset the appliance.

374

System characteristics

Burner restarts

Cause

Preparation for ionisation current calibration: Stabilisation conditions for pre-calibration not met.

Measures

- Check ionisation electrode and connecting cable.
- Check plug-in connections for loose contacts. Check the flue system. Remove flue gas recirculation if necessary.
- Check system for condensate backup. Visually check gas solenoid valve inlet and inlet strainer for contamination.

Note

To prevent water damage, detach fan unit before removing the burner.

Deposits on the electrodes indicate foreign bodies in the combustion air. Check the installation room and flue system for causes of the deposits. For example:

Laundry detergents, cleaning agents, toiletries, deposits in the ventilation air supply (chimney).

If burner gauze assembly and ionisation electrode have been replaced, also clean fan unit, gas/air channel and Venturi extension.

Reset the appliance.

375

System characteristics

Burner restarts.

Cause

Performing ionisation current calibration: Calibration not performed. Minimum value or termination criterion not reached.

Measures

- Check ionisation electrode and connecting cable.
- Check plug-in connections for loose contacts. Check the flue system. Remove flue gas recirculation if necessary.

- Check system for condensate backup. Visually check gas solenoid valve inlet and inlet strainer for contamination.

Note

To prevent water damage, detach fan unit before removing the burner.

Deposits on the electrodes indicate foreign bodies in the combustion air. Check the installation room and flue system for causes of the deposits (e.g. laundry detergents, cleaning agents, toiletries or deposits in the ventilation air supply/chimney).

If burner gauze assembly and ionisation electrode have been replaced, also clean fan unit, gas/air channel and Venturi extension.

- Reset the appliance.

376

System characteristics

Burner in a fault state

Cause

Ionisation current differential compared to previous value not plausible.

Fault messages (cont.)

Measures

- Check ionisation electrode and connecting cable.
- Check plug-in connections for loose contacts. Check the flue system. Remove flue gas recirculation if necessary.
- Check system for condensate backup. Visually check gas solenoid valve inlet and inlet strainer for contamination.

Note

To prevent water damage, detach fan unit before removing the burner.

Deposits on the electrodes indicate foreign bodies in the combustion air. Check the installation room and flue system for causes of the deposits (e.g. laundry detergents, cleaning agents, toiletries or deposits in the ventilation air supply/chimney).

If burner gauze assembly and ionisation electrode have been replaced, also clean fan unit, gas/air channel and Venturi extension.

Reset the appliance.

377

System characteristics

Burner in a fault state

Cause

Post-processing of ionisation current calibration: Stabilisation conditions for post-calibration not met

Measures

Check gas type setting. If the fault occurs repeatedly, replace the HBMU heat management unit. See chapter "Replacing the HBMU heat management unit". Reset the appliance.

378

System characteristics

Burner in a fault state

Cause

Flame loss during stabilisation or operating phase

Measures

- Check gas supply (gas pressure and gas flow switch).
 - Check flue gas recirculation.
 - Check for contamination of ionisation electrode and burner gauze assembly.
- Reset the appliance.

379

System characteristics

Burner in a fault state

Cause

Flame signal not present or insufficient

Measures

- Check ionisation electrode connecting cable for damage and firm seating.
 - Check ionisation electrode. Replace if necessary.
- Reset the appliance.

Fault messages (cont.)

380

System characteristics

Burner in a fault state

Cause

Flame is lost immediately after flame formation (during safety time)

Measures

Check gas supply (gas pressure and gas flow switch).

Check balanced flue system for flue gas recirculation.

Check ionisation electrode and burner gauze assembly:

- Clearance to burner gauze assembly
- Contamination on electrode

Reset the appliance.

381

System characteristics

Burner in a fault state

Cause

Flame loss during operating phase

Measures

Check gas supply (gas pressure and gas flow switch).

Check balanced flue system for flue gas recirculation.

Check ionisation electrode and burner gauze assembly:

- Clearance to burner gauze assembly
- Contamination on electrode

Reset the appliance.

382

System characteristics

Burner in a fault state

Cause

Fault counter has exceeded limit.

Measures

Reset the appliance. Work through fault analysis using fault history.

383, 384

System characteristics

Burner in a fault state

Cause

Possible contamination of gas line

Measures

- Check gas line for contamination.
- Check the gas supply pressure.
- Replace gas fan if necessary.

Reset the appliance.

385

System characteristics

Burner in a fault state

Cause

Short circuit, signal 1, ionisation current
HBMU heat management unit faulty

Fault messages (cont.)

Measures

Reset the appliance.

Check IO electrode for earth fault. If the fault persists, replace the HBMU heat management unit.

386

System characteristics

Burner in a fault state

Cause

HBMU heat management unit faulty

Measures

Replace the HBMU heat management unit. See chapter "Replacing the HBMU heat management unit".
Reset the appliance.

387

System characteristics

Burner in a fault state

Cause

Ionisation current earth fault, HBMU heat management unit faulty.

Measures

Check ionisation electrode and connecting cable. If the fault persists, replace the HBMU heat management unit. See chapter "Replacing the HBMU heat management unit".
Reset the appliance.

388

System characteristics

Burner in a fault state

Cause

HBMU heat management unit faulty

Measures

Replace the HBMU heat management unit. See chapter "Replacing the HBMU heat management unit".
Reset the appliance.

393

System characteristics

Burner in a fault state

Cause

Short circuit, flue gas temperature sensor 2.

Measures

Check flue gas temperature sensor 2 and leads to sensor.
Reset the appliance.

394

System characteristics

Burner in a fault state

Cause

Lead break, flue gas temperature sensor 2.

Measures

Check flue gas temperature sensor 2 and leads to sensor. Replace sensor if necessary.
Reset the appliance.

399

System characteristics

Burner in a fault state

Cause

IO electrode earth fault, HBMU heat management unit faulty

Measures

Check IO electrode for earth fault. If the fault persists, replace the HBMU heat management unit. See chapter "Replacing the HBMU heat management unit".
Reset the appliance.

400

System characteristics

Burner in a fault state

Cause

HBMU heat management unit faulty

Measures

Replace the HBMU heat management unit. See chapter "Replacing the HBMU heat management unit".
Reset the appliance.

401

System characteristics

Burner in a fault state

Cause

IO electrode earth fault, HBMU heat management unit faulty

Measures

Check IO electrode for earth fault. If the fault persists, replace the HBMU heat management unit. See chapter "Replacing the HBMU heat management unit".
Reset the appliance.

402

System characteristics

Burner in a fault state

Cause

HBMU heat management unit faulty

Measures

Replace the HBMU heat management unit. See chapter "Replacing the HBMU heat management unit".
Reset the appliance.

403

System characteristics

Burner in a fault state

Cause

Ionisation electrode earth fault, HBMU heat management unit faulty

Measures

Check IO electrode for earth fault. If the fault persists, replace the HBMU heat management unit. See chapter "Replacing the HBMU heat management unit".
Reset the appliance.

Fault messages (cont.)

404

System characteristics

Burner in a fault state

Cause

HBMU heat management unit faulty

Measures

Replace the HBMU heat management unit. See chapter "Replacing the HBMU heat management unit".
Reset the appliance.

405

System characteristics

Burner in a fault state

Cause

Ionisation electrode earth fault, HBMU heat management unit faulty

Measures

Check IO electrode for earth fault. If the fault persists, replace the HBMU heat management unit. See chapter "Replacing the HBMU heat management unit".
Reset the appliance.

406, 408, 410

System characteristics

Burner in a fault state

Cause

HBMU heat management unit faulty

Measures

Replace the HBMU heat management unit. See chapter "Replacing the HBMU heat management unit".
Reset the appliance.

416

System characteristics

Burner locked out

Cause

Flue gas temperature sensor incorrectly positioned

Measures

Fit flue gas temperature sensor correctly. See "Repairs".
Carry out mains reset after fault has been remedied.

417, 418

System characteristics

Burner in a fault state

Cause

HBMU heat management unit faulty

Measures

Replace the HBMU heat management unit. See chapter "Replacing the HBMU heat management unit".
Reset the appliance.

425

System characteristics

System operating normally; calculation not working
Calculation values can be viewed via software tool.

Cause

Time synchronisation failed

Fault messages (cont.)

Measures

Set the time.

446

System characteristics

Burner in a fault state

Cause

Deviation, heat generator flow temperature sensor/
high limit safety cut-out

Measures

Check the flow temperature sensor/high limit safety cut-out.

Check plug-in connection and lead to sensor.
Reset the appliance.

447, 448

System characteristics

Burner in a fault state

Cause

Deviation, ionisation voltage/ionisation current signal

Measures

Replace the HBMU heat management unit. See chapter "Replacing the HBMU heat management unit".
Reset the appliance.

449, 450, 451, 452

System characteristics

Burner in a fault state

Cause

Error in scheduled program run monitoring

Measures

Reset the appliance. If the fault occurs repeatedly, replace the HBMU heat management unit. See chapter "Replacing the HBMU heat management unit".

453

System characteristics

Burner in a fault state

Cause

Synchronisation error, sequence

Measures

Reset the appliance. If the fault occurs repeatedly, replace the HBMU heat management unit. See chapter "Replacing the HBMU heat management unit".

454

System characteristics

Burner in a fault state

Cause

Incorrect HBMU heat management unit parameter set

Measures

Flash correct HBMU heat management unit parameter set.

Fault messages (cont.)

455, 456

System characteristics

Burner in a fault state

Cause

Error in program run monitoring

Measures

Reset the appliance. If the fault occurs repeatedly, replace the HBMU heat management unit. See chapter "Replacing the HBMU heat management unit".

457

System characteristics

Burner in a fault state

Cause

Fan sluggish or blocked.

Measures

Reset the appliance.
Check fan for sluggishness. In the case of severe contamination or grinding noises, replace fan unit.

458

System characteristics

Burner in a fault state

Cause

Incorrect reset sequence.

Measures

Check connections between HBMU heat management unit and HMI programming unit.
Reset the appliance.

461

System characteristics

Burner in a fault state

Cause

Flue gas damper fault.

Measures

Check flue gas damper.

462

System characteristics

Burner in a fault state

Cause

Feedback input of the external gas safety valve causes the burner start to be aborted.

Measures

Check safety valve and connection.

463

System characteristics

Burner in a fault state

Cause

Contaminated combustion air, flue gas recirculation

Fault messages (cont.)

Measures

Check flue system for contamination and flue gas recirculation. Clean flue system if necessary. Reset the burner.

Note

Deposits on the electrodes indicate foreign bodies in the combustion air. Check the installation room and flue system for causes of the deposits. For example: Laundry detergents, cleaning agents, toiletries, deposits in the ventilation air supply (chimney). If burner gauze assembly and ionisation electrode have been replaced, also clean fan unit, gas/air channel and Venturi extension. Reset the appliance.

464

System characteristics

Burner in a fault state

Cause

Ionisation current too low during calibration. Differential compared to previous value not plausible.

Measures

- Check ionisation electrode and connecting cable. Check plug-in connections for loose contacts.
- Check whether there is a lot of dust in the ventilation air (e.g. from construction work).
- Check the flue system. Remove flue gas recirculation if necessary.
- Check system for condensate backup. Reset the appliance.

Note

To prevent water damage, detach fan unit before removing the burner.

If the fault is constant, replace the HBMU heat management unit: See chapter "Replacing the HBMU heat management unit".

Note

Deposits on the electrodes indicate foreign bodies in the combustion air. Check the installation room and flue system for causes of the deposits. For example: Laundry detergents, cleaning agents, toiletries, deposits in the ventilation air supply (chimney). If burner gauze assembly and ionisation electrode have been replaced, also clean fan unit, gas/air channel and Venturi extension.

467

System characteristics

Burner in a fault state

Cause

Gas supply insufficient during calibration. Contaminated or insufficiently sized gas line.

Measures

- Test static gas pressure and gas flow pressure.
- Check that on-site gas line and gas flow switch are correctly sized.

- Visually inspect gas solenoid valve inlet and inlet strainer for contamination.
- Reset the appliance.

Note

Contamination from a brazed gas line, for example, can block up the gas solenoid valve strainer on the inlet side.

468

System characteristics

Burner in a fault state

Cause

Ionisation current too high during calibration

Fault messages (cont.)

Measures

Check gap between ionisation electrode and burner gauze assembly.
 Check whether there is a lot of dust in the ventilation air (e.g. from construction work).
 Reset the appliance.

Note

*Deposits on the electrodes indicate foreign bodies in the ventilation air. Check the installation room and flue system for causes of the deposits. For example: Laundry detergents, cleaning agents, toiletries, deposits in the ventilation air supply (chimney).
 If burner gauze assembly and ionisation electrode have been replaced, also clean fan unit, gas/air channel and Venturi extension.*

471

System characteristics

No heat demand

Cause

System pressure sensor not available, lead break or short circuit

Measures

- Check system pressure sensor (plug 163).
- Check lead and plug-in connection.
- Check whether the supply voltage to the sensor is 5 V $\overline{=}$.

474

System characteristics

Burner in a fault state

Cause

Error in scheduled program run monitoring

Measures

Reset the appliance.
 If the fault occurs repeatedly, replace the HBMU heat management unit. See chapter "Replacing the HBMU heat management unit".

527, 528

System characteristics

Burner in a fault state

Cause

Incorrect HBMU heat management unit parameter set

Measures

Overwrite (flash) the HBMU heat management unit with the correct parameter set.

540

System characteristics

Burner in a fault state

Cause

Condensate backup in the heat cell

Note

To prevent water damage, detach fan unit before removing the burner.

Reset the appliance.

Measures

- Check system for condensate backup.
- Check the condensate drain and trap.
- Replace insulation blocks, electrodes and burner gauze assembly if necessary.

Fault messages (cont.)

574

System characteristics

Normal operation without room influence

Cause

Room temperature sensor, heating circuit 1 not available

Measures

Check external room temperature sensor for heating circuit or room temperature sensor on remote control unit.

Check setting of parameter 933.6

575

System characteristics

Normal operation without room influence

Cause

Lead break, room temperature sensor, heating circuit 1

Measures

Check external room temperature sensor for heating circuit or room temperature sensor on remote control unit.

576

System characteristics

Normal operation without room influence

Cause

Short circuit, room temperature sensor, heating circuit 1

Measures

Check external room temperature sensor for heating circuit or room temperature sensor on remote control unit.

577

System characteristics

Normal operation without room influence

Cause

Room temperature sensor, heating circuit 2 not available

Measures

Check external room temperature sensor for heating circuit or room temperature sensor on remote control unit.

Check setting of parameter 934.6

578

System characteristics

Normal operation without room influence

Cause

Lead break, room temperature sensor, heating circuit 2

Measures

Check external room temperature sensor for heating circuit or room temperature sensor on remote control unit.

Fault messages (cont.)

579

System characteristics

Normal operation without room influence

Cause

Short circuit, room temperature sensor, heating circuit 2

Measures

Check external room temperature sensor for heating circuit or room temperature sensor on remote control unit.

682

System characteristics

Burner in a fault state

Cause

Air mass flow rate sensor not available

Measures

Check air mass flow rate sensor.

683

System characteristics

Burner in a fault state

Cause

Air mass flow rate sensor faulty

Measures

Check air mass flow rate sensor.

694

System characteristics

Burner in a fault state

Cause

Signal comparison, deviation, flue gas high limit safety cut-out

Measures

Check plug-in connection and sensor lead.
Check sensor.
Replace sensor if necessary.
Reset the appliance.

738

System characteristics

Normal operation

Cause

OpenTherm remote control connected but not configured

Measures

Set **"C.7"** in the commissioning assistant to a value of 14.

Fault messages (cont.)

766

System characteristics

Burner output is reduced to minimum

Cause

Flue gas temperature too high.

Measures

Clean the heat cell. Perform maintenance.

767

System characteristics

Burner in a fault state

Cause

Flue gas temperature too high.

Measures

Clean the heat cell. Perform maintenance.

799

System characteristics

No DHW heating, no central heating

Cause

Central heating circuit pump reports an electrical fault. System cannot be operated as no flow can be made available.

Measures

Perform a power reset. If this occurs repeatedly, replace the heating circuit pump.

979

System characteristics

Constant heat demand. Set room temperature is exceeded

Cause

Both inputs – plug 96 **and** OpenTherm – are occupied and reporting a heat demand

Measures

Note

*Only one input can be used. Either plug 96 **or** OpenTherm.*

980

System characteristics

No DHW heating

Cause

Water flow rate below minimum level

Measures

Check that the cylinder flow and return are open. Check DHW setting in commissioning assistant and correct if necessary. Check pump. Replace if necessary. Pause time for DHW heating can be terminated by mains reset.

Fault messages (cont.)

981

System characteristics

No DHW heating

Cause

Water flow rate below minimum level

Measures

Check that the cylinder flow and return are open. Check DHW setting in commissioning assistant and correct if necessary. Check pump. Replace if necessary. Pause time for DHW heating can be terminated by mains reset.

982

System characteristics

No central heating, no DHW heating

Cause

Circulation pump heating circuit 1 running dry

Measures

Check diaphragm expansion vessel and circulation pump.

Repairs



Please note

Residual water will escape when the boiler or one of the following components is fitted or removed:

- Water-filled pipework
- Heat exchanger
- Circulation pumps
- Plate heat exchanger
- Components fitted in the heating water or DHW circuit.

Water ingress can result in damage to other components.

Protect the following components against ingress of water:

- Control unit components (especially in the service position)
- Electrical components
- Plug-in connections
- Cables and leads

Shutting down the boiler

1. Turn off the power supply at the ON/OFF switch.
2. Shut off the gas supply.
3. If the boiler needs to be removed:
 - Isolate the system from the power supply, e.g. by removing the separate fuse or by means of a mains isolator, and check that it is no longer live.
 - Safeguard the system against reconnection.
 - Disconnect the balanced flue system.
 - Drain the boiler on the heating water and DHW sides.
 - Disconnect the on-site cables/leads.

Removing the boiler from the pre-plumbing jig or mounting frame

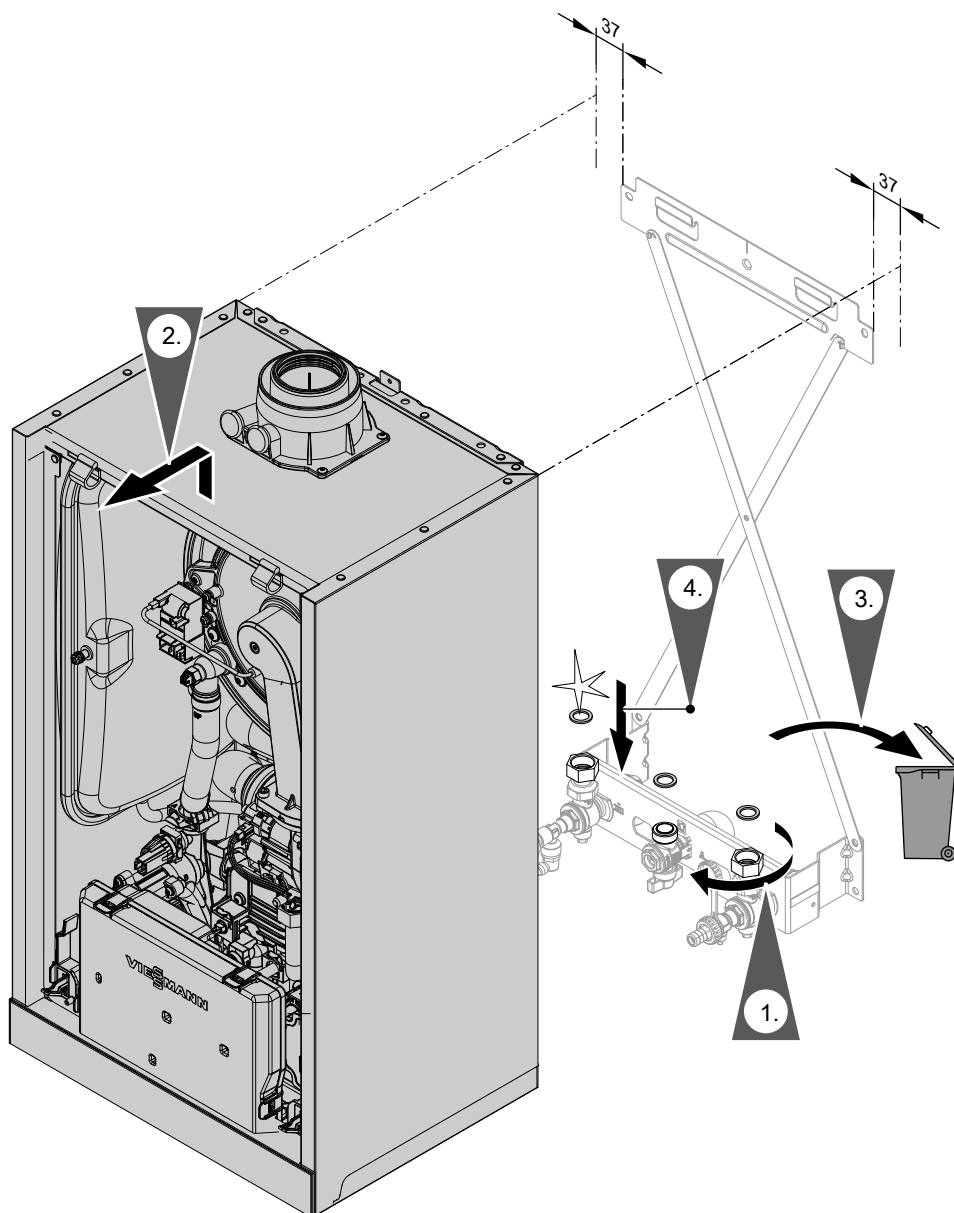

Fig. 45

Note
When assembling, use new gaskets and, if required, new locking ring fittings.

Internal gasket diameter:

- Gas connection \varnothing 18.5 mm
- Connections on the heating water side \varnothing 17.0 mm

Gaskets and locking ring connections are available as individual parts (if required).

Note
When carrying out any work on gas connection fittings, hold with a suitable tool. Never transfer any forces to the internal components.



Danger
Escaping gas leads to a risk of explosion. Check all connections on the gas side (also inside the appliance) for tightness.

Checking the temperature sensors

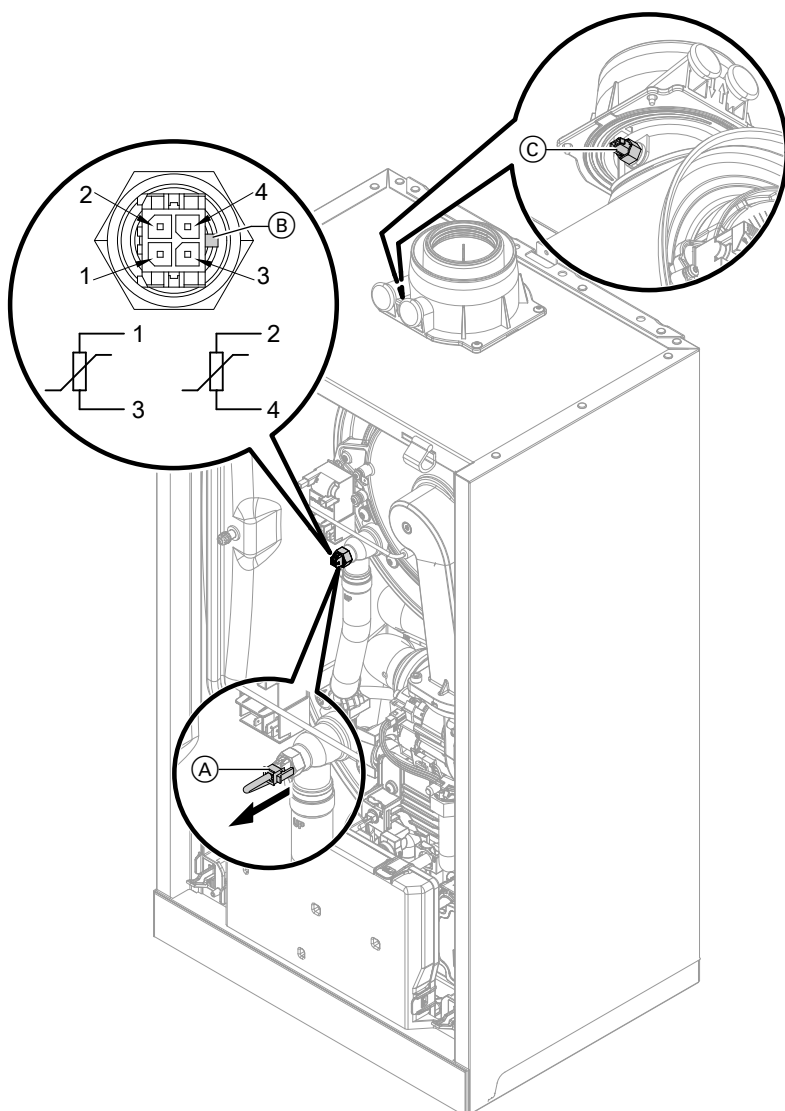

Fig. 46

Heat generator circuit flow temperature sensor (dual sensor)

1. Check the leads and plugs of flow temperature sensors (A).
2. Disconnect the leads from flow temperature sensors (A).

3. Check the sensor resistance. Note position of guide lug (B).
 - Sensor 1: Connections 1 and 3
 - Sensor 2: Connections 2 and 4

Compare the resistances with the value for the current temperature from the following diagram. In the event of severe deviation (> 10 %), replace the dual sensor.



Danger

The dual sensor is directly immersed in the heating water (risk of scalding). Drain the boiler on the heating water side before replacing the sensor.



Danger

Risk of electric shock from escaping heating water
Check the dual sensor for leaks.

Repairs (cont.)

Cylinder temperature sensor/outlet temperature sensor

1. Check lead and plug of the cylinder temperature sensor or outlet temperature sensor.
2. Disconnect wires 3 and 4 from terminal S.T.S.
3. Check the sensor resistance. Compare the resistance with the value for the current temperature from the following diagram.
In the event of severe deviation (> 10 %), replace the sensor.

Outside temperature sensor

1. Check the lead and plug of the outside temperature sensor.
2. Disconnect wires 3 and 4 from terminal O.T.S.
3. Check the sensor resistance. Compare the resistance with the value for the current temperature from the following diagram.
If the results are very different from the curve (> 10 %), disconnect the wires from the sensor. Repeat the test directly on the sensor.
Check the on-site lead. 2-core lead, up to 35 m long with 1.5 mm² cross-section
Depending on the test result, replace the lead or the outside temperature sensor.

- Flue gas temperature sensor
- Flow temperature sensor
- Cylinder temperature sensor
- Outlet temperature sensor

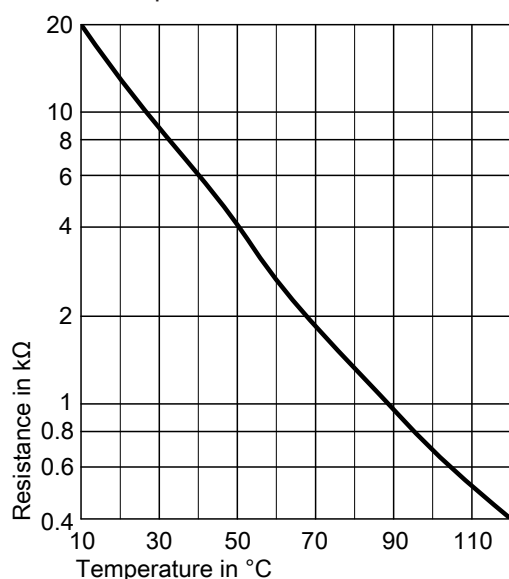

Sensor type: NTC 10 kΩ

Flue gas temperature sensor

1. Check the lead and plug of flue gas temperature sensor (C).
2. Disconnect leads, flue gas temperature sensor (C).
3. Rotate sensor (anti-clockwise) by ¼ turn to remove it (bayonet fitting).
4. Check the sensor resistance. Compare the resistance with the value for the currently recorded temperature from the following diagram.
In the event of severe deviation (> 10 %), replace the sensor.
5. Rotate sensor (clockwise) by ¼ turn to install it.



Danger

Escaping flue gas can cause poisoning. When restarting, check for leaks on the flue gas side.

6. Reconnect leads, flue gas temperature sensor (C).
7. If the permissible flue gas temperature has been exceeded, the flue gas temperature sensor locks out the appliance. Reset the burner on the programming unit once the flue system has cooled down.

- Outside temperature sensor

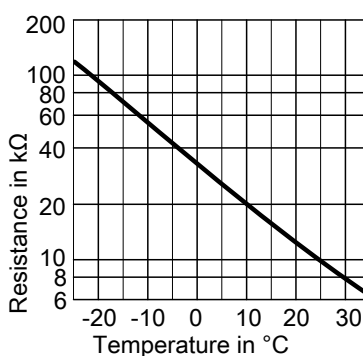

Sensor type: NTC 10 kΩ

Repairs (cont.)

Fault during commissioning (fault message 416)

During commissioning, the control unit checks for correct placement of the flue gas temperature sensor. If fault message 416 is displayed:

1. Check whether the flue gas temperature sensor is correctly installed (bayonet fitting). See previous diagram.
2. If required, correct the position of the flue gas temperature sensor.
3. Check the flue gas temperature sensor resistance. See previous chapter. Replace faulty flue gas temperature sensor if required.

4. Turn off the ON/OFF switch.
5. Turn the ON/OFF switch back on. Restart the commissioning assistant.
6. Check for leaks on the flue gas side.

Note

If fault message 416 continues to be displayed although the flue gas temperature sensor is correctly positioned: Initial commissioning may result in burner faults e.g. caused by air in the gas line. Eliminate the fault and reset the appliance.

Replacing the HBMU heat management unit

Note

If replacing the HBMU heat management unit, "ViGuide" must be used.



See spare part installation instructions and internet address: www.viguide.info

Replacing the power cable

When replacing the power cable, only use the power cable available as an individual part from Viessmann.

Replacing the HMI connecting cable



Please note

Incorrect routing of the cable can lead to heat damage and impairment of the EMC properties. For positioning and securing of the cable (fixing point of the cable tie) see connecting cable installation instructions.

Checking the plate heat exchanger

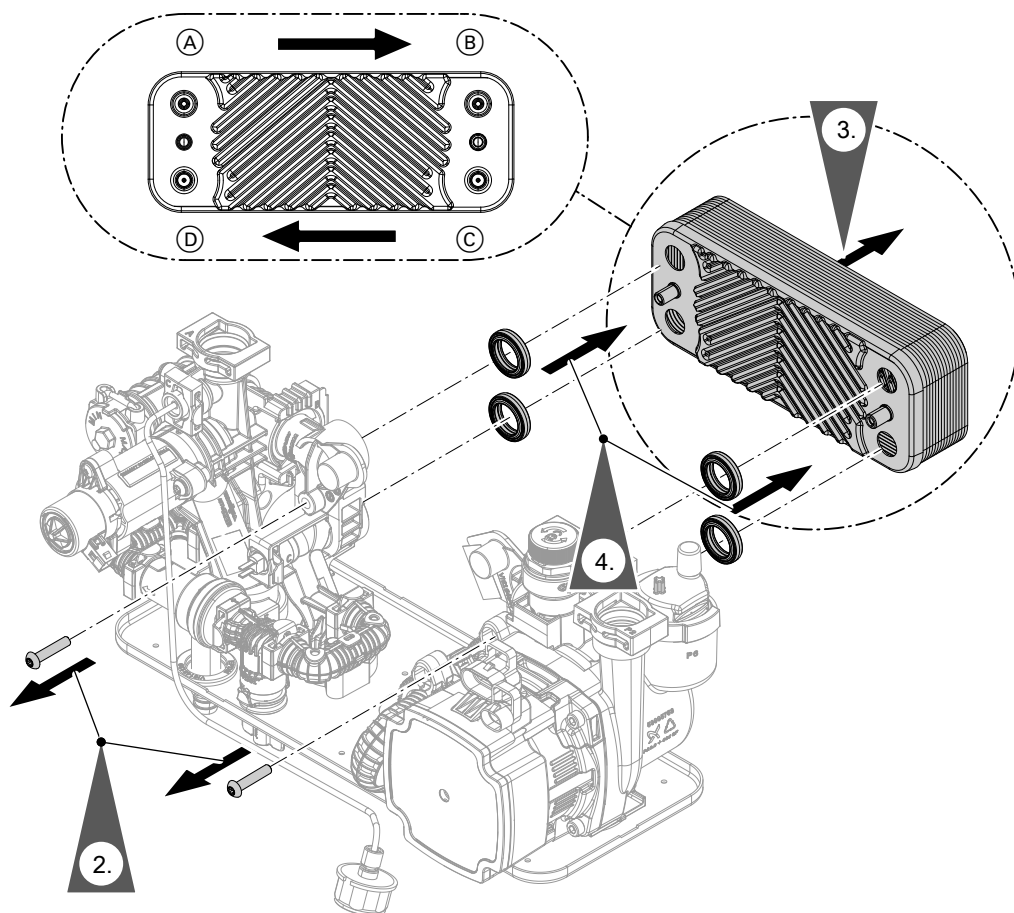

Fig. 47

- (A) Heating water flow
- (B) Heating water return

- (C) Cold water
- (D) DHW

1. Shut off and drain the boiler on the heating water and DHW sides.
2. Undo the screws.
3. Remove plate heat exchanger.

Note

During and after removal, small amounts of water may trickle from the plate heat exchanger.

4. Remove gaskets and dispose of them.
5. Check connections on the DHW side for scaling. Clean or replace the plate heat exchanger as required.
6. Check connections on the heating water side for contamination. Clean or replace the plate heat exchanger as required.

7. Install plate heat exchanger in reverse order using new gaskets. Tighten screws as tightly as necessary and ensure that the components are undamaged and are functioning correctly throughout service life. Observe torque settings if a torque wrench is available. Screw torque: 3.2 Nm ± 0.2

Note

During installation, ensure the connections are positioned and the gaskets seated correctly.



Danger

Risk of electric shock from escaping heating water or DHW
Check all water side connections for tightness.

Repairs (cont.)

Removing the hydraulic unit

If components of the hydraulic unit have to be replaced.

⚠ Danger
 Risk of electric shock from escaping heating water or DHW
 After installation, check all connections on the water side for leaks.

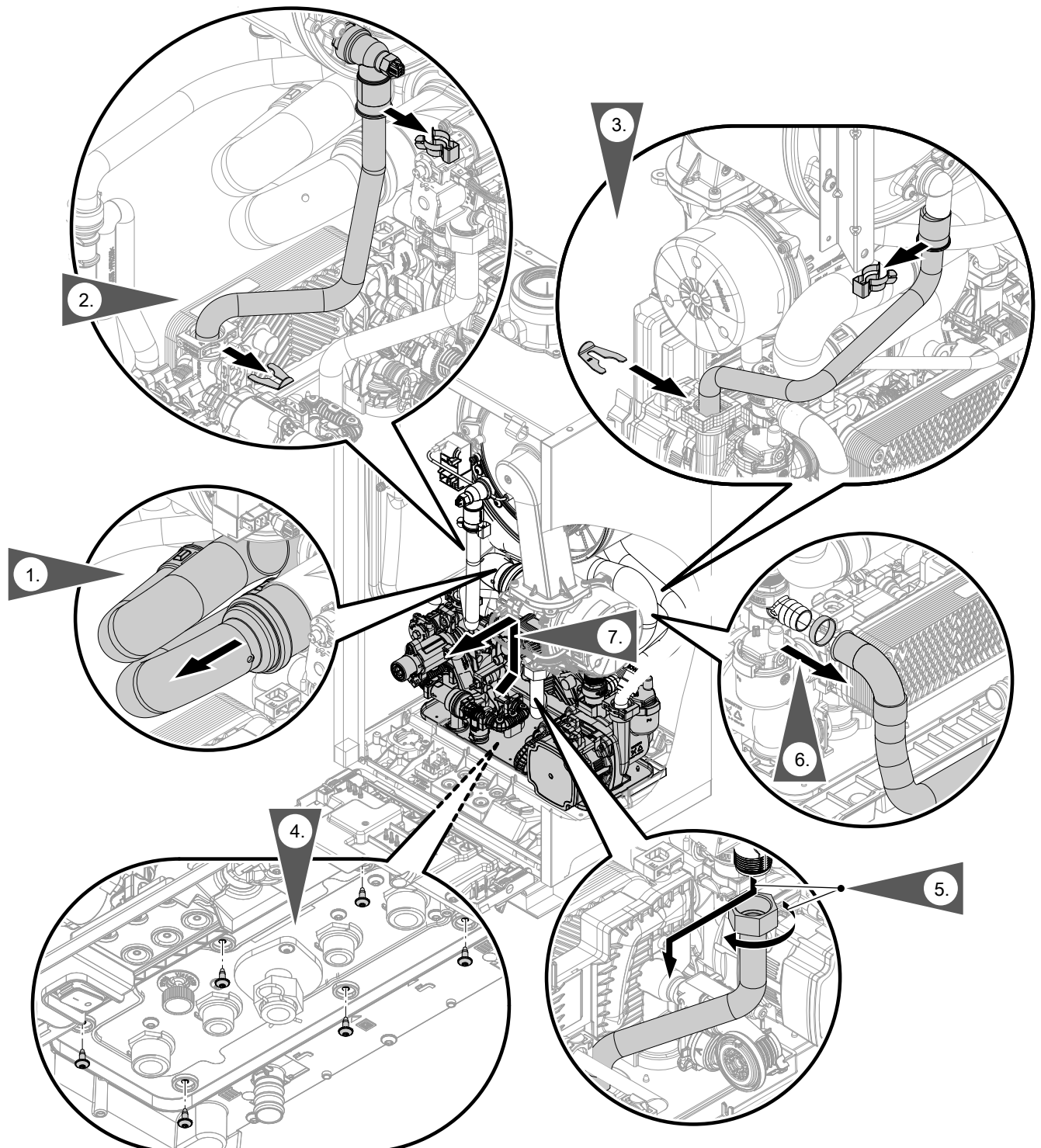

Fig. 48

Checking the fuse

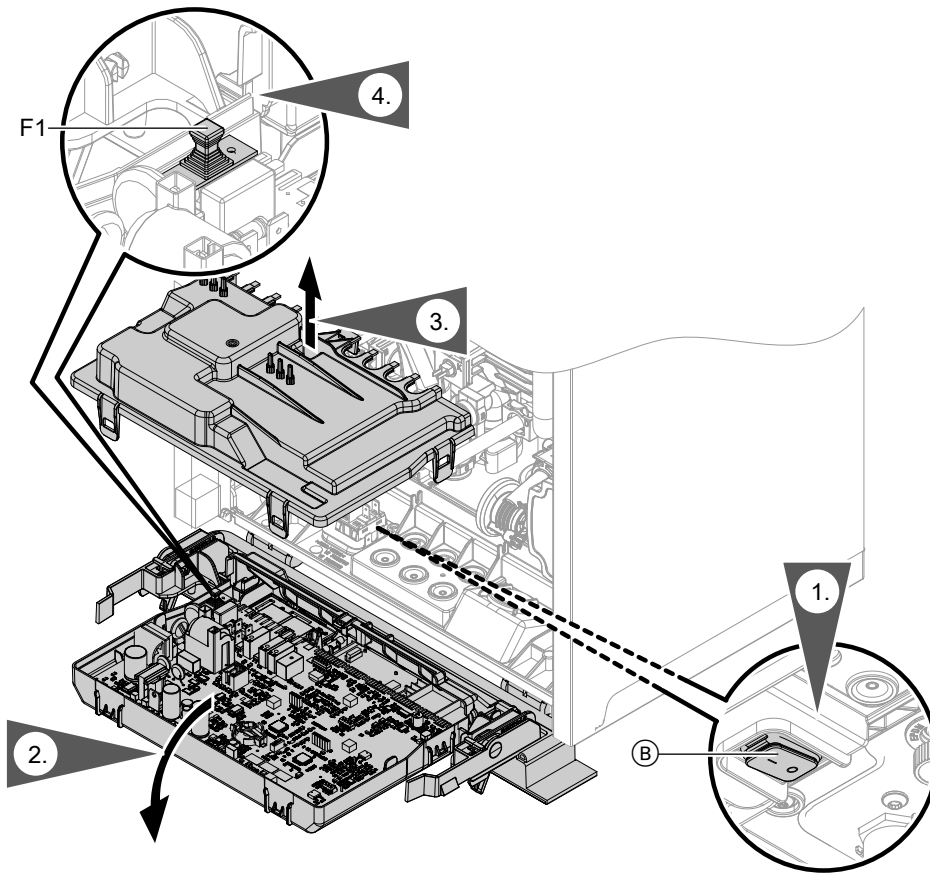

Fig. 49

1. Turn off ON/OFF switch (B).
2. Pivot the HBMU heat management unit down.
3. Remove the cover.
4. Check fuse F1 (see connection and wiring diagram).



Danger

Incorrect or improperly fitted fuses can lead to an increased risk of fire.

- Insert fuses without using any force. Position fuses correctly.
- Only use structurally identical types with the specified response characteristics.

Appliance functions

Heating mode

- **Weather-compensated operation:**

The rooms are heated in accordance with the room temperature settings.

The control unit determines a set flow temperature for the heat generator, subject to the outside temperature, the room temperature and the slope/level of the heating curve.

- **Room temperature-dependent operation (constant operation with room thermostat):**

System with one heating circuit without mixer. The rooms are heated in accordance with the settings of the room temperature controller/room thermostat (accessories).

If the room temperature controller/room thermostat issues a demand, the standard set flow temperature is maintained. If there is no demand, the frost protection function is active.

- **Constant operation without room thermostat:**

The rooms are heated according to the set flow temperature settings.

- **OpenTherm:**

Rooms are heated in accordance with the settings of the room temperature controller/room thermostat (accessories). The OpenTherm controller specifies the flow temperature for the heat generator.

OpenTherm controller

In systems with one heating circuit without mixer:

The flow temperature and the DHW temperature are based on the settings of the OpenTherm controller (accessories).

Venting program

During the venting program, the circulation pump will be alternately switched on and off for 30 s over a period of 20 min.

The 3-way diverter valve alternates between central heating and DHW heating for a certain period of time. The burner is switched off during the venting program.



Activate venting program: See chapter "Commissioning, inspection and maintenance".

Filling program

In the delivered condition, the 3-way diverter valve is set to its central position, so the system can be filled completely. After the control unit has been switched on, the 3-way diverter valve no longer goes into its central position.

If the system is to be filled with the control unit switched on, the 3-way diverter valve is moved to its central position in the filling program and the pump is started.



Activate filling program: See chapter "Commissioning, inspection and maintenance".

In this position, the control unit can be switched off and the system can be filled completely. When the function is enabled, the burner shuts down. The program automatically becomes inactive after 20 min.

Heating curve

The heating curves represent the relationship between the outside temperature and the flow temperature.

Simplified: The lower the outside temperature, the higher the flow temperature must be in order to reach the set room temperature.

Factory settings:

- Slope = 1.4
- Level = 0

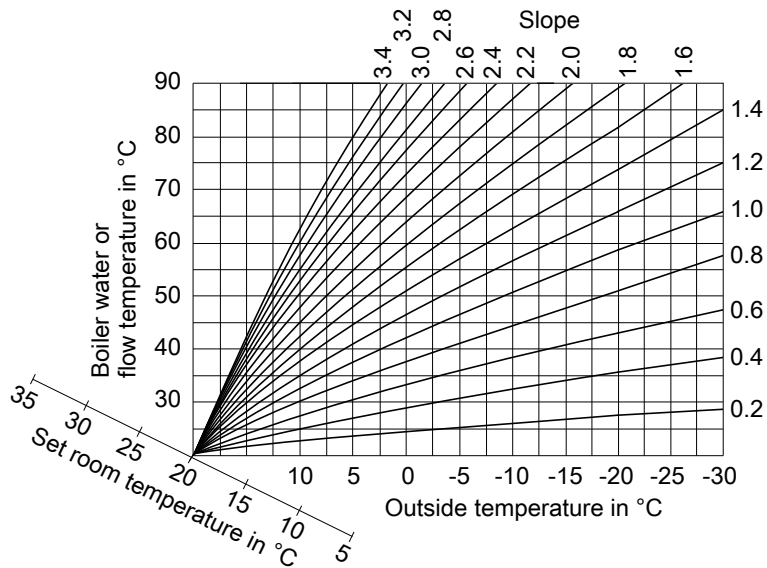

Fig. 50

Slope setting ranges:

- Underfloor heating systems: 0.2 to 0.8
- Low temperature heating systems: 0.8 to 1.6

Set room temperature

Standard room temperature

Individually adjustable for each heating circuit. The heating curve is offset along the set room temperature axis. The start and stop points of the heating circuit pumps depend on the Heating limit, outside temperature for heating circuit... setting.

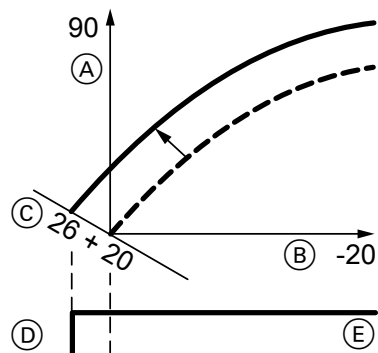

Fig. 51 Example 1: Changing the set room temperature from 20 to 26 °C

- (A) Flow temperature in °C
- (B) Outside temperature in °C
- (C) Set room temperature in °C
- (D) Heating circuit pump "OFF"
- (E) Heating circuit pump "ON"

Changing the set room temperature



Operating instructions

Changing the slope and level

Individually adjustable for each heating circuit

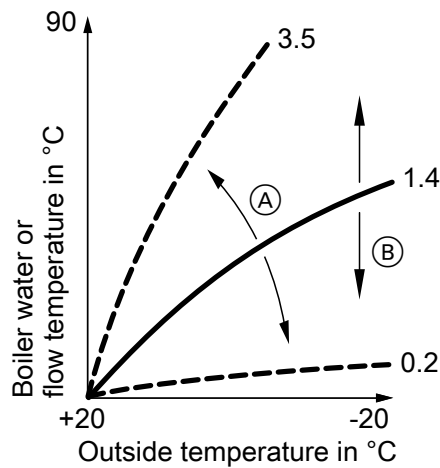

Fig. 52

- (A) Changing the slope.
- (B) Changing the level (vertical parallel offset of the heating curve).

DHW heating (system boilers only)

The burner, the circulation pump and the 3-way diverter valve are started or changed over if the cylinder temperature lies 2.5 K below the set cylinder temperature.

In the delivered condition, the set boiler water temperature is 20 K higher than the set cylinder temperature. If the actual cylinder temperature exceeds the set cylinder temperature by 2.5 K, the burner shuts down and circulation pump run-on begins (only with separate DHW cylinder).



Danger

Risk of injury due to increased DHW temperature.

Inform the system user of the risk from the raised outlet temperature at the draw-off points.

- Gas condensing system boiler:
If the set DHW temperature is set to over 60 °C
- Gas condensing combi boiler:
If there are several draw-off events in quick succession or several appliance calibration processes

External heating circuit hook-up (if installed)

Note

Only in conjunction with weather-compensated operation.

- Function:
 - If the external demand is active, the heating circuit is supplied with heat.
 - If the external demand is inactive (contact open), heat supply to the heating circuit ends (regardless of the current set room temperature or the switching time).



Please note

There is no frost protection for the connected heating circuits.

- Connection:
 - If just one heating circuit is web connected, use plug 96.

HBMU heat management unit

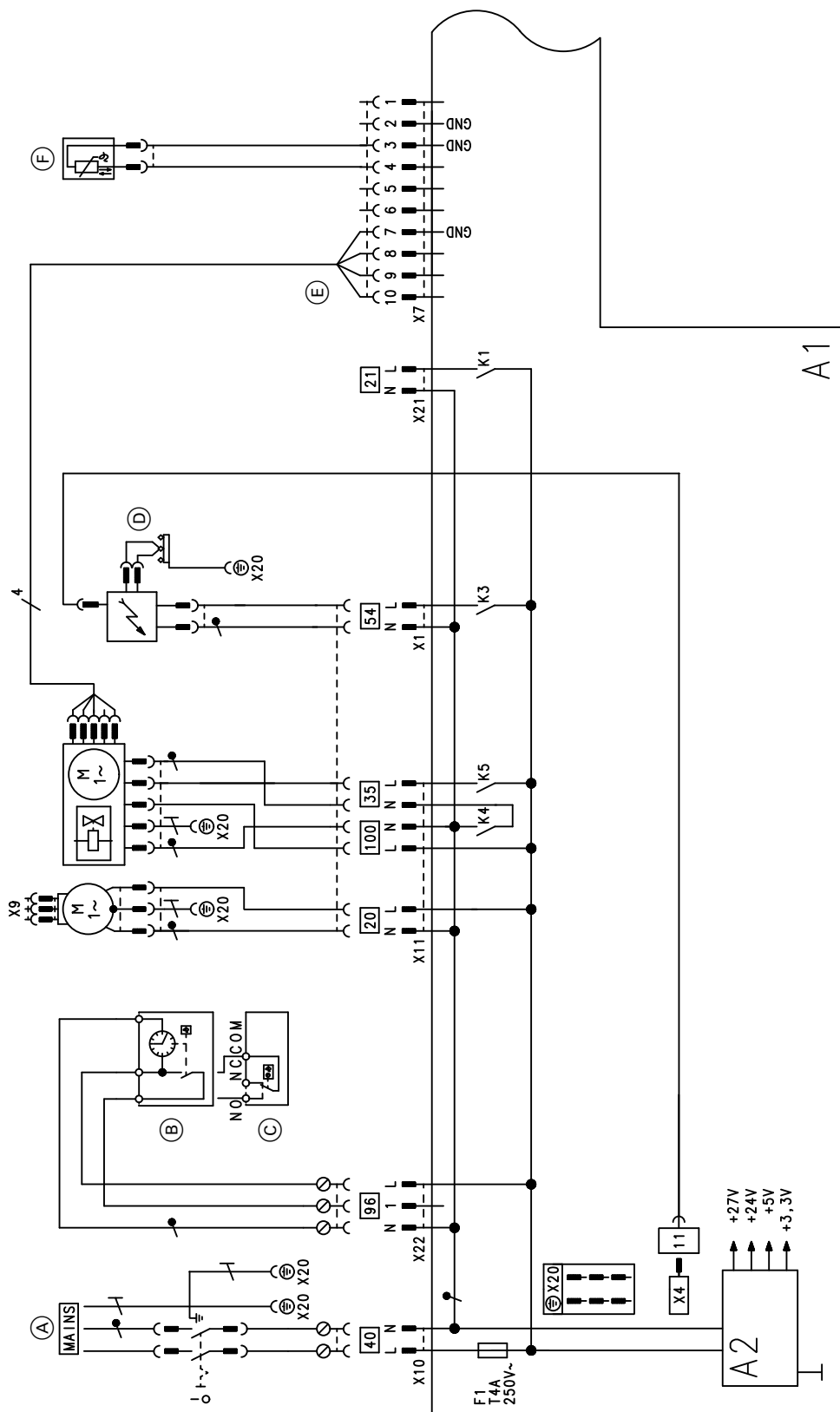

Fig. 53

- A1 HBMU heat management unit
- A2 Power supply unit
- X... Electrical interfaces
- (A) Power supply 230 V/50 Hz
- (B) Vitotrol 100, type UTA
- (C) Vitotrol 100, type UTDB
- (D) Ignition unit/ionisation

- (E) Fan motor control
- (F) Outlet temperature sensor (combi boiler only)
- 96 Connection accessory 230 V
- 100 Fan motor 230 V
- 35 Gas solenoid valve
- 54 Ignition unit

HBMU heat management unit (cont.)

- 40 Mains input
- 21 No function

HBMU heat management unit

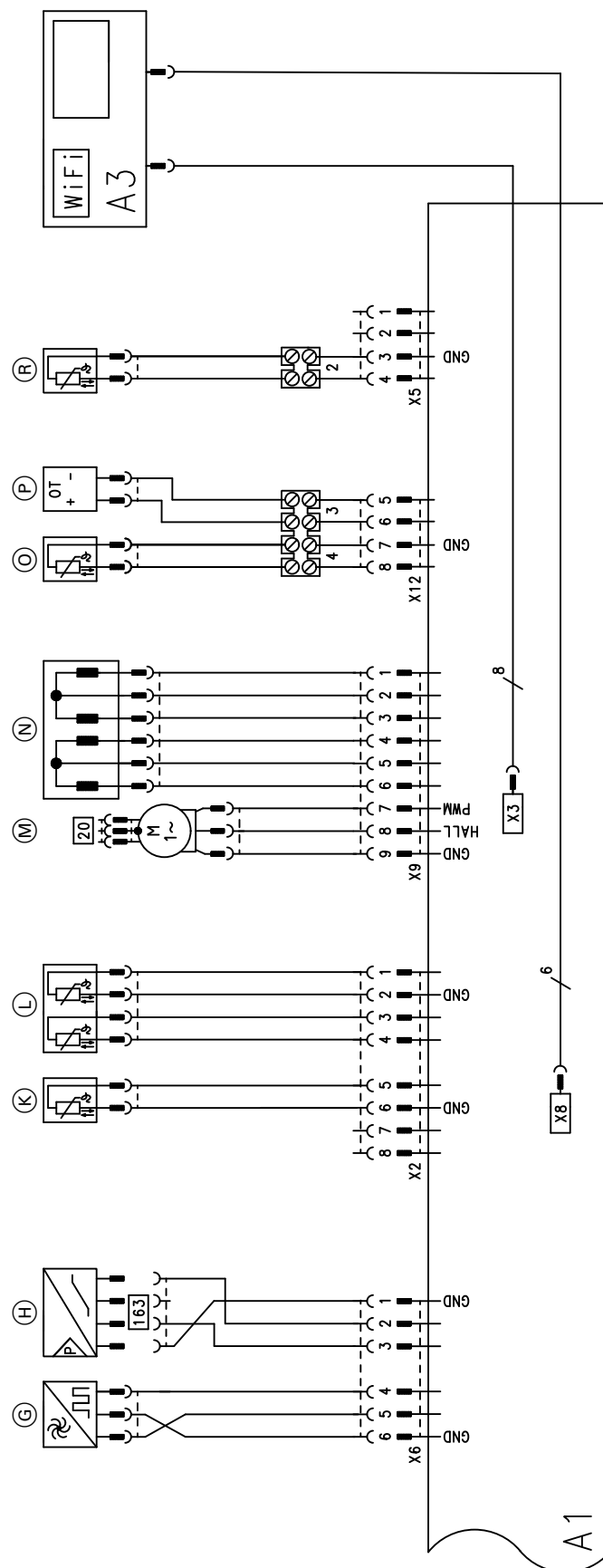

Fig. 54

- A1 HBMU heat management unit
- A3 Programming unit with communication module
- X... Electrical interfaces
- Ⓒ Flow sensor (combi boiler only)

- Ⓗ Water pressure sensor
- Ⓚ Flue gas temperature sensor
- Ⓛ Boiler water temperature sensor
- Ⓜ Internal circulation pump (PWM)

HBMU heat management unit (cont.)

- Ⓝ Stepper motor for diverter valve
- Ⓞ Outside temperature sensor

- Ⓟ Remote control (OpenTherm controller)
- Ⓠ Cylinder temperature sensor (system boiler only)

Report

Settings and test values		Set value	Commissioning	Maintenance/service	Maintenance/service
Date					
Signature					
Static pressure	mbar kPa	≤ 57.5 ≤ 5.75			
Supply pressure (flow pressure)					
<input type="checkbox"/> With natural gas	mbar kPa	See table "Supply pressure" (Commissioning ...)			
<input type="checkbox"/> Enter gas type.					
Carbon dioxide content CO₂ With natural gas					
▪ At lower heating output	% by vol.	See "Checking the combustion quality" (Commissioning ...)			
▪ At upper heating output	% by vol.				
Oxygen content O₂					
▪ At lower heating output	% by vol.				
▪ At upper heating output	% by vol.				
Carbon monoxide content CO					
▪ At lower heating output	ppm	< 1000			
▪ At upper heating output	ppm	< 1000			
Settings and test values		Set value	Commissioning	Maintenance/service	Maintenance/service
Date					
Signature					
Static pressure	mbar kPa	≤ 57.5 ≤ 5.75			
Supply pressure (flow pressure)					
<input type="checkbox"/> For natural gas	mbar kPa	See table "Supply pressure" (Commissioning ...)			
<input type="checkbox"/> Enter gas type.					
Carbon dioxide content CO₂ With natural gas					

(cont.)

Settings and test values		Set value	Commissioning	Maintenance/service	Maintenance/service
▪ At lower heating output	% by vol.	See "Checking the combustion quality" (Commissioning ...)			
▪ At upper heating output	% by vol.				
Oxygen content O₂					
▪ At lower heating output	% by vol.				
▪ At upper heating output	% by vol.				
Carbon monoxide content CO					
▪ At lower heating output	ppm	< 1000			
▪ At upper heating output	ppm	< 1000			

Gas condensing combi boiler

Gas boiler, type B and C, category I _{2N} /I _{2H}				
Type		B0KA		
Rated heating output range (to EN 15502) T _F /T _R = 50/30 °C				
Natural gas	kW	3.2 (7.0 ^{*1}) to 19.0	3.2 (7.0 ^{*1}) to 25.0	3.2 to 32.0
LPG	kW	3.2 to 19	3.2 to 25	3.2 to 32.0
T_F/T_R = 80/60 °C				
Natural gas	kW	2.9 (6.3 ^{*1}) to 17.0	2.9 (6.3 ^{*1}) to 22.5	2.9 to 29.3
LPG	kW	2.9 to 17	2.9 to 22.5	2.9 to 29.3
Rated heating output for DHW heating				
Natural gas	kW	2.9 (6.3 ^{*1}) to 25.4	2.9 (6.3 ^{*1}) to 30.0	2.9 to 34.2
LPG	kW	2.9 to 25.4	2.9 to 30	2.9 to 34.2
Rated heat input (Q_n)				
Natural gas	kW	3.0 (6.5 ^{*1}) to 18.0	3.0 (6.5 ^{*1}) to 23.6	3.0 to 29.9
LPG	kW	3.0 to 18.0	3.0 to 23.6	3.0 to 29.9
Rated heat input for DHW heating (Q_{nw})				
Natural gas	kW	3.0 (6.5 ^{*1}) to 26.7	3.0 (6.5 ^{*1}) to 31.5	3.0 to 34.9
LPG	kW	3.0 to 26.7	3.0 to 31.5	3.0 to 34.9
Product ID		CE-0063DL3422		
IP rating		IPX4 to EN 60529		
NO_x		6	6	6
Gas supply pressure				
Natural gas	mbar	20	20	20
	kPa	2	2	2
LPG	mbar	50	50	50
	kPa	5	5	5
Max. permiss. gas supply pressure^{*2}				
Natural gas	mbar	25	25	25
	kPa	2.5	2.5	2.5
LPG	mbar	25 to 57.5	25 to 57.5	25 to 57.5
	kPa	2.5 to 5.75	2.5 to 5.75	2.5 to 5.75
Sound power level (to EN ISO 15036-1)				
▪ At partial load	dB(A)	33	33	31.9
▪ At rated heating output (DHW heating)	dB(A)	52	53	53
Power consumption (in the delivered condition)		48	67	113
Rated voltage		V 230		
Rated frequency		Hz 50		
Appliance fuse protection		A 4		
Backup fuse (power supply)		A 16		

^{*1} Appliances for multiple connection of type B0KA-[kW]-M

^{*2} If the gas supply pressure is higher than the maximum permissible value, install a separate gas pressure governor upstream of the system.

Gas condensing combi boiler (cont.)

Gas boiler, type B and C, category I _{2N} /I _{2H}				
Type		B0KA		
Rated heating output range (to EN 15502)				
T _F /T _R = 50/30 °C				
Natural gas	kW	3.2 (7.0 ^{*1}) to 19.0	3.2 (7.0 ^{*1}) to 25.0	3.2 to 32.0
LPG	kW	3.2 to 19	3.2 to 25	3.2 to 32.0
T _F /T _R = 80/60 °C				
Natural gas	kW	2.9 (6.3 ^{*1}) to 17.0	2.9 (6.3 ^{*1}) to 22.5	2.9 to 29.3
LPG	kW	2.9 to 17	2.9 to 22.5	2.9 to 29.3
Communication module (integral)				
WiFi frequency band	MHz	2400 to 2483.5		
Max. transmission power	dBm	20		
Low power radio frequency band	MHz	2400 to 2483.5		
Max. transmission power	dBm	10		
Supply voltage	V \equiv	24		
Power consumption	W	4		
Electronic temperature limiter setting (TN)	°C	91		
Electronic temperature cut-out setting	°C	110		
Electronic flue gas temperature limiter setting	°C	110		
Permissible ambient temperature				
▪ During operation	°C	+5 to +40		
▪ During storage and transport	°C	-5 to +60		
Weight				
▪ Excl. heating water and packaging	kg	35	35	37
▪ Incl. heating water	kg	41	41	43
Water capacity (excl. diaphragm expansion vessel)	l	3.0	3.0	3.0
Max. flow temperature	°C	82	82	82
Max. flow rate (Limit for the use of hydraulic separation)	l/h	See residual head graphs		
Nominal circulating water volume At T _F /T _R = 80/60 °C	l/h	752	988	
Diaphragm expansion vessel				
▪ Capacity	l	8	8	8
▪ Pre-charge pressure	bar	0.75	0.75	0.75
	kPa	75	75	75
Permiss. operating pressure	bar	3	3	3
	MPa	0.3	0.3	0.3
Connections (with connection accessories)				
▪ Boiler flow and return	G	¾	¾	¾
▪ Cold water and DHW	G	½	½	½

Gas condensing combi boiler (cont.)

Gas boiler, type B and C, category I _{2N} /I _{2H}				
Type		B0KA		
Rated heating output range (to EN 15502)				
T _F /T _R = 50/30 °C				
Natural gas	kW	3.2 (7.0 ^{*1}) to 19.0	3.2 (7.0 ^{*1}) to 25.0	3.2 to 32.0
LPG	kW	3.2 to 19	3.2 to 25	3.2 to 32.0
T _F /T _R = 80/60 °C				
Natural gas	kW	2.9 (6.3 ^{*1}) to 17.0	2.9 (6.3 ^{*1}) to 22.5	2.9 to 29.3
LPG	kW	2.9 to 17	2.9 to 22.5	2.9 to 29.3
Dimensions				
▪ Length	mm	300	300	300
▪ Width	mm	400	400	400
▪ Height	mm	700	700	700
Gas connection	R	M 22x1.5	M 22x1.5	M 22x1.5
Standby instantaneous water heater				
DHW and cold water connections	G	1/2	1/2	1/2
Permissible operating pressure (DHW side)	bar	10	10	10
	MPa	1	1	1
Minimum pressure, cold water connection	bar	1	1	1
	MPa	0.1	0.1	0.1
Outlet temperature, adjustable	°C	10 to 60	10 to 60	10-60
Continuous DHW output	kW	26.3	30.9	34.4
Spec. water flow rate (D) at ΔT = 30 K (EN 13203-1)	l/min	13.26	15.59	17.04
Supply values				
Relative to the max. load and 1013 mbar/15 °C				
Natural gas E	m ³ /h	1.88	2.48	3.69
Natural gas LL	m ³ /h	2.19	2.88	4.29
LPG	kg/h	1.4	1.83	2.71
Flue gas parameters				
Temperature (at a return temperature of 30 °C)				
▪ At rated heating output	°C	41	46	59
▪ At partial load	°C	38	38	38
Temperature (at a return temperature of 60 °C, for DHW heating)	°C	65	67	72
Overheating temperature	°C	120		
Mass flow rate (for DHW heating)				
Natural gas				
▪ At max. rated heating output	kg/h	31.7	41.6	62.1
▪ At partial load	kg/h	5.6 (9.8 ^{*1})	5.6 (9.8 ^{*1})	5.6
Available draught (with single connection)	Pa	250	250	250
	mbar	2.5	2.5	2.5

*1 Appliances for multiple connection of type B0KA-[kW]-M

Gas condensing combi boiler (cont.)

Gas boiler, type B and C, category I _{2N} /I _{2H}				
Type	B0KA			
Rated heating output range (to EN 15502) T _F /T _R = 50/30 °C				
Natural gas	kW	3.2 (7.0 ^{*1}) to 19.0	3.2 (7.0 ^{*1}) to 25.0	3.2 to 32.0
LPG	kW	3.2 to 19	3.2 to 25	3.2 to 32.0
T _F /T _R = 80/60 °C				
Natural gas	kW	2.9 (6.3 ^{*1}) to 17.0	2.9 (6.3 ^{*1}) to 22.5	2.9 to 29.3
LPG	kW	2.9 to 17	2.9 to 22.5	2.9 to 29.3
Max. amount of condensate To DWA-A 251	l/h	3.8	4.4	4.9
Condensate connection (hose nozzle)	Ø mm	20 to 24	20 to 24	20 to 24
Flue gas connection	Ø mm	60	60	60
Ventilation air connection	Ø mm	100	100	100
Standard seasonal efficiency [to DIN] at T _F /T _R = 40/30 °C		Up to 98 (H _s) [gross cv]		
Energy efficiency class		A	A	A

Note

The supply values are only for reference (e.g. in the gas contract application) or for a supplementary, rough estimate to check the volumetric settings. Due to factory settings, the gas pressure must not be altered from these values. Reference: 15 °C, 1013 mbar (101.3 kPa).

Flue system types

Available in the following countries	Flue system types
AE, AM, AZ, BA, BG, BY, CH, CY, CZ, DK, EE, ES, FI, FR, GB, GR, HR, HU, IE, IS, IT, KG, KZ, LT, LV, MD, ME, MT, NL, NO, PL, PT, RO, RS, RU, SE, SK, TR, UA, UZ	B ₂₃ , B _{23P} , B ₃₃ , C ₁₃ , C ₃₃ , C ₅₃ , C ₆₃ , C ₈₃ , C _{83P} , C ₉₃ (C ₄₃ , C _{43P} , C ₍₁₀₎₃ , C ₍₁₁₎₃ , C ₍₁₃₎₃ , C ₍₁₄₎₃ ^{*3})
AU, BE, NZ	B ₂₃ , B _{23P} , B ₃₃ , C ₁₃ , C ₃₃ , C ₅₃ , C ₈₃ , C _{83P} , C ₉₃ (C ₄₃ , C _{43P} , C ₍₁₀₎₃ , C ₍₁₁₎₃ , C ₍₁₃₎₃ , C ₍₁₄₎₃ ^{*3})
DE, LU, SI	B ₂₃ , B _{23P} , B ₃₃ , C _{13X} , C _{33X} , C _{53X} , C _{63X} , C _{83X} , C _{93X} (C ₄₃ , C _{43P} , C ₍₁₀₎₃ , C ₍₁₁₎₃ , C ₍₁₃₎₃ , C ₍₁₄₎₃ ^{*3})
CN	C13

^{*1} Appliances for multiple connection of type B0KA-[kW]-M

^{*3} Only for specifically marked appliances.

Specification

Gas categories

Available in the following countries	Gas categories	
AE, AM, AZ, BA, BG, BY,CY, CZ, DK, EE, ES, FI, GB, GR, HR, IE, IT, IS, KG, KZ, LT, LU, LV, MD, ME, MT, NO, PT, RO, RS, RU, SE, SK, TR, UA, UZ	I _{2N} /I _{2H}	2N/2H - G 20 - 20 mbar
AM, AZ, BY, MD, KG, KZ, RU, UA, UZ	I _{2N} /I _{2H}	2N/2H - G 20 - (13) 20 mbar
BE, FR	I _{2N}	2N - G 20/G 25 - 20/25 mbar
EN	I _{2N}	2N - G 20/G 25 - 20 mbar
HU	I _{2N} /I _{2H}	2N/2H - G 20 - 20 mbar
NL	I _{2EK}	2E - G 20 - 20 mbar 2K - G 25.3 - 25 mbar
PL	I _{2N} /I _{2ELW}	2N/2E - G 20 - 20 mbar 2N/2Lw - G 27 - 20 mbar

Electronic combustion control unit

The electronic combustion controller utilises the physical correlation between the level of the ionisation current and the air ratio λ . The maximum ionisation current is achieved at an air ratio of 1 for all gas qualities. The ionisation signal is evaluated by the combustion controller. The air ratio is regulated to a value that is between $\lambda= 1.2$ and 1.5. This range provides for an optimum combustion quality. Thereafter, the electronic gas train regulates the required gas volume subject to the prevailing gas quality.

To check the combustion quality, the CO₂ content or the O₂ content of the flue gas is measured. The prevailing air ratio is determined using the actual values.

To achieve optimum combustion control, the system regularly carries out an automatic self-calibration; also after power failures (shutdown). For this, the combustion is briefly regulated to maximum ionisation current (corresponding to air ratio $\lambda=1$). Self-calibration takes place shortly after the burner starts. The process lasts approx. 20 s during which higher than normal CO emissions may occur briefly.

Final decommissioning and disposal

Viessmann products can be recycled. Components and substances from the system are not part of ordinary domestic waste.

For decommissioning, isolate the system from the power supply and allow components to cool down where appropriate.
All components must be disposed of correctly.

Declaration of conformity

We, Viessmann Climate Solutions SE, D-35108 Allendorf, declare as sole responsible body that the named product complies with the European directives and supplementary national requirements in terms of its design and operational characteristics. Viessmann Climate Solutions SE, D-35108 Allendorf, hereby declares that the radio equipment type of the named product is in compliance with Directive 2014/53/EU.

Using the serial number, the full Declaration of Conformity can be found on the following website:

www.viessmann.co.uk/eu-conformity

Keyword index

- A**
Angle of penetration..... 18
- B**
Back draught safety device..... 50
Boiler, fitting..... 20, 22
Boiler, removing..... 90
Boiler water temperature sensor..... 91
Burner gasket..... 47
Burner gauze assembly..... 47
Burner installation..... 53
Burner removal..... 46
- C**
Circulation pump rate, adjusting..... 42
Combustion chamber, cleaning..... 51
Combustion controller..... 110
Combustion quality, checking..... 56
Commissioning assistant..... 33
Condensate connection..... 25
Condensate drain..... 52
Connecting cables, routing..... 30
Connecting cables/leads, routing..... 29
Connections, water side..... 24
Connection schemes..... 100
Control unit
– Wiring diagram..... 100
Control unit functions..... 97
Cylinder temperature sensor..... 91
- D**
DHCP..... 17
DHW heating..... 99
DHW hygiene..... 57
DHW temperature, raised..... 57
Diaphragm expansion vessel..... 36
Dynamic IP addressing..... 17
- E**
Electrical connections..... 27, 28
Electronic combustion controller..... 110
Expansion vessel..... 54
- F**
Fault codes..... 63
Fault message, calling up..... 62
Fault message 416..... 93
Fault messages
– Display..... 62
Faults
– Commissioning..... 41
– Display..... 62
Filling function..... 36, 97
Fill water..... 35
Flow limiter..... 54
Flow pressure..... 40
Flow temperature sensor..... 91
Flue gas connection..... 26
Flue gas temperature sensor..... 92
Front panel, mounting..... 31
Front panel removal..... 20, 38
Function descriptions..... 97
Function sequence..... 41
Fuse..... 96
- G**
Gas connection..... 26
Gas solenoid valve..... 40
Gas supply pressure..... 40
Gas type..... 38
- H**
Heating curve..... 57, 97
Heating curve level..... 98
Heating curve slope..... 98
Heating output setting..... 42
Heating surface, cleaning..... 51
Heating system, filling..... 35
Heating system, venting..... 37
Hydraulic unit removal..... 95
- I**
Ignition..... 49
Ignition electrodes..... 49
Intended use..... 11
Internet, connecting..... 35
Ionisation electrode..... 49
IP addressing..... 17
- L**
Language selection..... 33
Leak test, balanced flue system..... 45
- M**
Mains isolator..... 38, 55
Main switch..... 46
Message history..... 62
Multiple connection to shared flue system..... 45
- O**
OpenTherm controller..... 97
Operating conditions, checking..... 60
Operating data, calling up..... 61
Operating data, checking..... 60
Operating modes..... 97
Operational reliability..... 17
Output adjustment
– Multiple connection..... 45
Outside temperature sensor..... 29, 91
Overview of electronics modules..... 63

Keyword index (cont.)

P		Set room temperature, setting.....	98
Parameters.....	58	Specification.....	106
– Adjusting.....	58	Static pressure.....	40
– Calling up.....	58	Subscriber number of connected component.....	62
– Energy saving functions, heating circuit.....	59	Supply pressure.....	39, 40
– Max. speed, heating circuit pump.....	58	Symbols.....	11
– Maximum flow temperature limit, heating circuit 1 .	59	System configuration.....	33, 58
– Maximum heating output.....	59	System filling.....	36
– Minimum heating output.....	59	System pressure.....	36
– Pump activation, heating circuit pump in standby mode.....	59	System requirements.....	17
– Scald protection activation.....	58	System schemes.....	57
Parameters for commissioning.....	57	T	
Plate heat exchanger.....	94	Tightness test.....	37
Port 123.....	17	Trap.....	25, 52
Port 443.....	17	Type plate.....	12
Port 80.....	17	V	
Port 8883.....	17	Venting function.....	38
Power supply.....	30	Venting program.....	97
R		W	
Range of WiFi connections.....	17	WiFi connection.....	35
Repairs.....	89	WiFi connection range.....	17
Report.....	104	WiFi network.....	35
Requirements.....	17	WiFi router.....	17
S		Wiring chamber, closing.....	31
Seal rings, replacing.....	37	Wiring chamber opening.....	27
Security parameters.....	17	Wiring diagram.....	100
Service menu.....	60		
– Calling up.....	60		
– Exiting.....	60		



Viessmann Climate Solutions SE
35108 Allendorf / Germany
Telephone: +49 6452 70-0
Fax: +49 6452 70-2780
www.viessmann.com



Viessmann Limited
Hortonwood 30, Telford
Shropshire, TF1 7YP, GB
Telephone: +44 1952 675000
Fax: +44 1952 675040
E-mail: info-uk@viessmann.com

6221465 Subject to technical modifications.