

Installation and Maintenance Instructions

Gas-fired condensing combi appliance

Greenstar 2000

GR2301iW

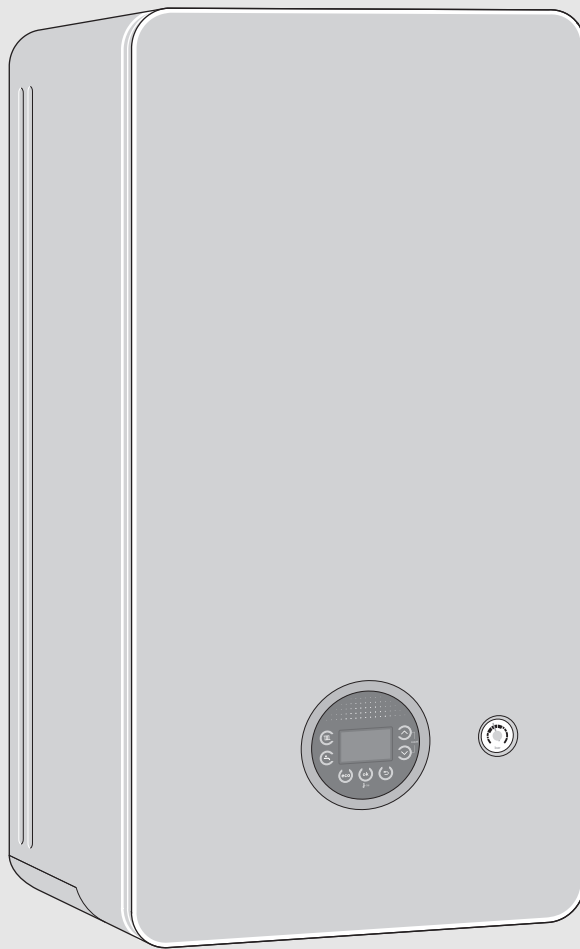

Table of contents

1	Explanation of symbols and safety instructions	4
1.1	Explanation of symbols	4
1.2	General safety instructions	4
2	Regulations	6
3	Product Information	7
3.1	Scope of delivery	7
3.2	Declaration of Conformity	7
3.3	Simplified UK/EU Declaration of conformity regarding radio equipment	7
3.4	Regulations	8
3.5	Appliance type overview	8
3.6	Product identification	8
3.7	Pipe work positions and flue outlet	9
3.8	Product overview	10
3.9	Product data for energy consumption	11
3.10	Standard accessories	11
3.10.1	Appliance accessories	11
3.10.2	Programmer/timer accessories	11
4	Pre-Installation	12
4.1	System preparation	12
4.1.1	Artificially softened water	12
4.1.2	Water systems and pipework	12
4.1.3	System layouts examples	13
4.1.4	System fill	14
4.2	Mains supply	14
4.2.1	Electrical supply	14
4.2.2	Gas supply	14
4.2.3	Gas supply	15
4.2.4	Water supply	16
4.3	Appliance location and clearances	16
4.3.1	Appliance location	16
4.3.2	Rooms containing a bath or shower	17
4.3.3	Appliance clearances	18
4.4	Flue systems considerations	19
4.4.1	Flue length	20
4.4.2	Flue options	20
4.4.3	Plume management system	22
4.4.4	Flue terminal positions	24
4.4.5	Plume re-direct and plume management terminal positions	27
4.5	Condensate discharge	29
4.5.1	Condensate pipework	29
4.5.2	Condensate production	29
4.5.3	Internal connections	29
4.5.4	External connections	30
4.6	Pressure relief discharge	34
4.6.1	Pressure relief pipework	34
4.6.2	Alternative PRV connections - Combined PRV/condensate	34
4.7	Cleaning primary systems	35
4.7.1	Flushing the system	36
5	Installation	37
5.1	Position the appliance	38
5.1.1	Mounting bracket fixing	38
5.2	Appliance connections	39
5.3	Hanging the appliance	40
5.4	Flue turret/adaptor installation	41
5.5	Electrical connection	42
5.5.1	Component access	43
5.5.2	Installer connections	43
5.5.3	Cable preparations	45
5.5.4	External controls - Domestic installations	45
6	Commissioning	46
6.1	Pre-Commissioning checks	46
6.2	Water treatment	46
6.2.1	Filling the appliance and adding inhibitor	47
6.3	Circulation pump characteristic curve	48
6.4	Starting the appliance	48
6.4.1	Control panel overview	48
6.4.2	Screen display	49
6.4.3	Switching on the device	49
6.4.4	Setting the flow temperature	49
6.4.5	Setting the DHW heating	50
6.4.6	Setting the heating control device	50
6.4.7	After commissioning	50
6.4.8	Setting summer mode	50
6.4.9	Manual mode	50
6.5	Chimney sweep mode	50
6.5.1	Setting the appliance to maximum	50
6.5.2	Setting the appliance to minimum	51
6.5.3	Exiting chimney sweep mode	51
6.6	Checking gas inlet pressure	51
6.7	Checking the gas rate	52
6.8	Checking for gas leaks during operation	52
6.9	CO and combustion check	52
6.10	Checking flue integrity	54
6.11	Flue gas analysis	54
6.12	Finishing commissioning	55
6.12.1	Fitting the front panel	55
6.12.2	Fitting the infills	55
6.12.3	Appliance/product guarantee	55
7	Shutdown	56
7.1	Setting frost protection	56
7.2	Anti-seize protection	56

8	Settings in the service menu	56	13	Technical Specifications/Logs	92
8.1	Operating the service menu	56	13.1	Technical data	92
8.2	Service functions overview	57	13.2	Component resistance characteristics	95
8.2.1	Menu 1	57	13.2.1	Sensor values	95
8.2.2	Menu 2	57	13.3	Heating curve	95
8.2.3	Menu 3	58	13.4	Internal wiring of the appliance	96
8.2.4	Menu 4	59	13.4.1	Electrical wiring	96
8.2.5	Menu 5	60	13.5	Setting values for output	97
8.2.6	Menu 6	61	13.5.1	Gas setting values (Natural Gas)	97
8.2.7	Menu 0	61	13.6	Gas Boiler System Commissioning Checklist and Warranty Validation Record	98
9	Inspection and maintenance	62	13.7	Inspection and maintenance checklist	99
9.1	Safety-relevant components	62	13.8	Service and Interim Boiler Work Record	100
9.2	Inspection and maintenance considerations	62			
9.3	Service functions	63	14	Data Protection Notice	102
9.4	Component access	63			
9.5	Fan pressure test	63			
9.5.1	Checking heat exchanger assembly	63			
9.6	Check working gas inlet pressure	64			
9.7	Flue gas analysis	64			
9.8	Checking the flue integrity	64			
9.9	Cleaning the siphon and heat exchanger	65			
9.9.1	Cleaning the heat exchanger	65			
9.9.2	Cleaning the siphon	67			
9.10	Setting the air/gas ratio	68			
10	Replacement parts	70			
10.1	Component access	70			
10.2	Draining the appliance	70			
10.3	Checking the strainer in the cold water pipe	71			
10.4	Checking the flow turbine	71			
10.5	Checking the plate heat exchanger	73			
10.6	Checking the expansion vessel	73			
10.7	Adjusting the operating pressure of the heating system	74			
10.8	Removing the gas valve	74			
10.9	Removing the pump	75			
10.10	Removing the automatic air vent valve	75			
10.11	Checking/replacing the motor of the 3-way valve	75			
10.12	Removing the heat exchanger assembly	76			
10.13	Replacing the control unit	77			
10.14	Reattaching the casing on the side	77			
10.15	Replacing the expansion vessel	77			
11	Fault finding and diagnosis	78			
11.1	General information	78			
11.2	Fault code table	79			
11.3	Pump operation and diagnosis	89			
11.4	Faults that are not displayed	90			
12	Environmental protection and disposal	91			

1 Explanation of symbols and safety instructions

1.1 Explanation of symbols

Warnings

In warnings, signal words at the beginning of a warning are used to indicate the type and seriousness of the ensuing risk if measures for minimising danger are not taken.

The following signal words are defined and can be used in this document:



DANGER indicates that severe or life-threatening personal injury will occur.



WARNING indicates that severe to life-threatening personal injury may occur.



CAUTION indicates that minor to medium personal injury may occur.



NOTICE indicates that material damage may occur.

Important information



The info symbol indicates important information where there is no risk to people or property.

Additional symbols

Symbol	Meaning
▶	a step in an action sequence
→	a reference to a related part in the document
•	a list entry
–	a list entry (second level)

Table 1

1.2 General safety instructions

⚠ Please read these instructions carefully before starting installation.

- These instructions are applicable to the Worcester appliance model(s) stated on the front cover of this manual only and must not be used with any other make or model of appliance.
- These instructions apply in the UK only and must be followed except for any statutory obligations.
- This appliance must be installed by a competent registered gas engineer, such as a **Gas Safe** registered engineer including a **British Gas** engineer. Failure to install correctly could lead to prosecution.
- If you are in any doubt, contact the Worcester, Bosch Group help line (0330 123 3366).
- Distance learning and training courses are available from Worcester.
- The BENCHMARK Commissioning Checklist can be found on page 98 of this Installation manual.

⚠ Notices for the target group

These installation instructions are intended for gas, plumbing, heating and electrical contractors. All instructions must be observed. Failure to comply with instructions may result in material damage and personal injury, including danger to life.

- ▶ Read the installation, service and commissioning instructions (heat source, heating controller, pumps, etc.) before installation.
- ▶ Observe the safety instructions and warnings.
- ▶ Follow national and regional regulations, technical regulations and guidelines.
- ▶ Record all work carried out.

⚠ Intended use

The appliance may only be used for heating water or domestic hot water in domestic properties.

- ▶ Observe the details on the data plate and the specifications (installation manual) to ensure correct use of this appliance.
- ▶ Worcester, Bosch Group offer flue gas systems which are suitable for use with the appliance. It is the responsibility of the installer of the flue to ensure this flue gas system operates correctly and in a safe manner.

⚠ Misuse

Appliance must be used as per the intended use statement. Operation outside the parameters of the intended use is considered misuse and could cause harm to people and damage to property.

Accessories should be as per accessories list. Minimum operational parameters are included in this document.

Using the appliance outside of its intended use may also invalidate the manufacturer's guarantee.

⚠ If you smell gas

A gas leak could potentially cause an explosion. If you smell gas, observe the following rules:

- ▶ Prevent flames or sparks:
 - Do not smoke, use a lighter or strike matches.
 - Do not operate any electrical switches or unplug any equipment.
 - Do not use the telephone or ring doorbells.
- ▶ Turn off the gas at the meter or regulator.
- ▶ Open windows and doors.
- ▶ Warn your neighbours and leave the building.
- ▶ Prevent anyone from entering the building.
- ▶ Move well away from the building: call the National Gas Emergency Service on 0800 111 999.
- ▶ L.P.G. boilers: Call the supplier's number on the side of the gas tank.

⚠ Risk to life from carbon monoxide poisoning.

There is a risk to life from escaping flue gases

- ▶ Do not modify the flue gas system.
- ▶ Ensure that flue pipes and gaskets are undamaged.

If flue pipes are damaged or leaking:

- ▶ Turn off and isolate the appliance.
- ▶ Open windows and doors.
- ▶ If necessary, leave the building and warn your neighbours.
- ▶ Prevent anyone from entering the building.
- ▶ Rectify any damage to the flue system immediately.

⚠ Installation and maintenance

Installation and maintenance must only be carried out by a competent registered gas engineer, such as a Gas Safe registered engineer or British Gas engineer.

- ▶ Carry out a gas tightness test after completing work on gas-carrying components.
- ▶ Only use original spares.

⚠ Electrical work

Electrical work must only be carried out by a qualified electrician:

- ▶ Before starting electrical work;
 - Ensure that the electricity supply is safely isolated and secured to prevent inadvertent re-connection. Information on safe isolation can be found in the Health and Safety Executive guidance HSG85.
 - Using test equipment approved to GS38 to confirm that the electricity supply is disconnected.
 - Before touching live parts: Wait at least five minutes to discharge the capacitors.
- ▶ Refer to the manufacturer's information when installing non Worcester components and systems to the Worcester appliance.

⚠ Handover to the user

When handing over, instruct the user how to operate the heating system and inform the user about its operating conditions.

- ▶ Explain how to operate the heating system and draw the user's attention to any safety relevant action.
- ▶ In particular:
 - Advise that alterations, servicing and repairs must only be carried out by a competent, registered gas engineer, such as a Gas Safe registered engineer or British Gas engineer.
 - Advise the user to have the appliance and system serviced annually to help ensure economy, safety and reliability.
 - The heat generator may only be operated with the casing fitted and closed.
- ▶ Point out the possible consequences (including personal injury, danger to life and material damage) of improper or inadequate inspection, cleaning and maintenance.
- ▶ Point out the dangers of carbon monoxide (CO) and recommend the use of CO detectors.
- ▶ Leave the installation instructions with the completed Benchmark Checklist and the operating instructions with the user or at the gas meter.

⚠ Servicing

Advise the user to have the appliance and heating system thoroughly serviced annually by a competent, registered gas engineer, such as a Gas Safe registered engineer or British Gas engineer.

Approved spares must be used to help maintain the efficiency, safety and reliability of the appliance.

⚠ Benchmark Service Record

The service engineer must complete the Benchmark Service Record at the back of this manual after each service.



Benchmark places responsibilities on both manufacturers and installers.

The purpose is to ensure that customers are provided with the correct equipment for their needs, that it is installed, commissioned and serviced in accordance with the manufacturer's instructions by competent persons and that it meets the requirements of the appropriate Building Regulations. The Benchmark Checklist can be used to demonstrate compliance with Building Regulations and should be provided to the customer for future reference.

Installers are required to carry out installation, commissioning and servicing work in accordance with the Benchmark Code of Practice which is available from the Heating and Hotwater Industry Council who manage and promote the scheme.

Visit hhic.org.uk for more information.

⚠ Health and safety

The appliance contains no asbestos and no substances have been used in the construction process that contravene the COSHH Regulations (Control of Substances Hazardous to Health Regulations 1988).

⚠ Combustion and corrosive materials

Do not store or use any combustible materials (paper, thinners, paints etc.) inside or within the vicinity of the appliance.

Chemically aggressive substances can corrode the appliance and invalidate any warranty.

⚠ Fitting and modification

Fitting the appliance and any controls to the appliance may only be carried out by a competent engineer in accordance with the current Gas Safety (Installation and Use) Regulations.

Flue systems must not be modified in any way other than as described in the fitting instructions. Any misuse or unauthorised modifications to the appliance, flue or associated components and systems could invalidate the warranty. The manufacturer accepts no liability arising from any such actions, excluding statutory rights.

⚠ General manual handling guidelines

- ▶ Only remove packaging at the time of the final installation.
- ▶ Always use Health and Safety guidance for manual handling of an appliance.
 - Never lift or carry more than the safe guidance limit on your own.
 - Always use appropriate methods and equipment when lifting/carrying an appliance.
- ▶ Never lift or carry packages by the shipping straps.
- ▶ During handling and unpacking, wear safety gloves to prevent injuries to your hands.
- ▶ Dispose of packing materials appropriately.

⚠ Important handling instructions

Care should be taken when transporting, lifting and carrying the appliance.

- ▶ Use a means of transport suitable for handling appliances (e.g. sack truck with strap, stair climbing or step trolley).
- ▶ When handling appliances, secure them against a fall.
- ▶ Let only trained personnel undertake the handling.
- ▶ The correct method for handling heavy objects should be strictly observed, at all times.

2 Regulations

Installation regulations

Current Gas Safety (Installation and Use) Regulations:

All gas appliances must be installed by a competent, registered gas engineer, such as a Gas Safe registered engineer or British Gas engineer in accordance with the current regulations.

Failure to install appliances correctly could lead to prosecution.

The appliance must be installed in accordance with, and comply to, the current:

- ▶ Gas Safety Regulations
- ▶ IET Regulations
- ▶ Building Regulations (England)
- ▶ Building Regulations (Wales)
- ▶ Building Standards (Scotland) (Consolidation)
- ▶ Health and Safety Document 635 (The Electricity at Work Regulations 1989) and any other local requirements
- ▶ EU Regulations No. 2017/1369 - Energy Labelling (as retained in UK law and amended)
- ▶ EU Regulations No. 811/2013 - Energy Labelling (as retained in UK law and amended)

Building Regulations Part L1A (Current version) - new dwellings

If the installation is in a new build property or it is a first time installation in an existing property, the heating systems must conform to current building regulations Part L1A.

The exception to this are single storey, open plan dwellings where the living area is more than 70% of the total usable floor area. Then this type of dwelling can be controlled as one zone.

An alternative would be individual electronically controlled TRVs.

For dwellings with a floor area over 150m², separate time and temperature control for each zone is required. It is best practice to fit Thermostatic Radiator Valves (TRV's) to all radiators except the area where the room thermostat is sited.

Building Regulations Part L1B (Current version) - existing dwellings

For appliance replacements on an existing system, it is not necessary to zone the upstairs and downstairs separately, compliance with the zone requirements can be achieved by a single room thermostat or programmable room thermostat.

While the system is drained down, it is best practice to fit Thermostatic Radiator Valves (TRV's) to all radiators except the area where the room thermostat is sited.

British Standards

Where no specific instruction is given, reference should be made to the relevant British Standard codes of Practice.

- BS7074:1
 - Code of practice for domestic and hot water supply
- BS6891
 - Installation of low pressure gas pipework up to 28mm (R1)
- BS5546
 - Installation of gas hot water supplies for domestic purposes
- EN12828
 - Central heating for domestic premises
- BS5440:1
 - Flues and ventilation for gas appliances of rated heating not exceeding 70kW (net): Flues
- BS5440:2
 - Flues and ventilation for gas appliances of rated heating not exceeding 70kW (net): Air Supply
- BS7593
 - Treatment of water in domestic hot water central heating systems
- BS6798
 - Installation of gas fired boilers of rated input up to 70kW (net)
- BS7671
 - IET Wiring Regulations

LPG Installations

An appliance using LPG must not be installed in a room or internal space below ground level unless one side of the building is open to the ground.

Timber framed buildings

Where the appliance is to be fitted to a timber framed building the guidelines laid down in BS5440: Part 1 and IGE "Gas Installations in Timber Frame Buildings" should be adhered to.

Water supply:

All seals joints and compounds (including flux and solder) and components used as part of the secondary domestic water system must meet the requirements of the WRC and hold approval by a notified body, e.g. WRAS. The installation must also comply with the requirements of Part G of the Building Regulations.

3 Product Information

Appliance features

- Aluminium-silicon heat exchanger.
- NOx emissions 40mg/kWh.
- Direct burner ignition.
- Zero pressure governor gas valve with fully modulating fan.
- Display for appliance status and access to diagnostics, system and commissioning parameters.
- 1 hour memory retention after power interruption.
- Low electrical power consumption in operation and stand-by modes.
- Low energy modulating pump.
- Condensing in CH and DHW modes.
- DHW Eco mode, to use gas on demand.
- Galvanised steel wall mounting bracket.
- Compatible with Worcester standard and intelligent controls.
 - See accessories list for available controls.
- Condensfit II flue systems 60/100 and 80/125 mm allows plume re-direction.
- Condensfit II flue systems 60/100 allows the ability to attach plume management kit.
- Front accessible components for maintenance.
- Quick Tap water saving function.

CH Water

Salt based artificially softened water must not be used to fill the central heating system.

3.1 Scope of delivery

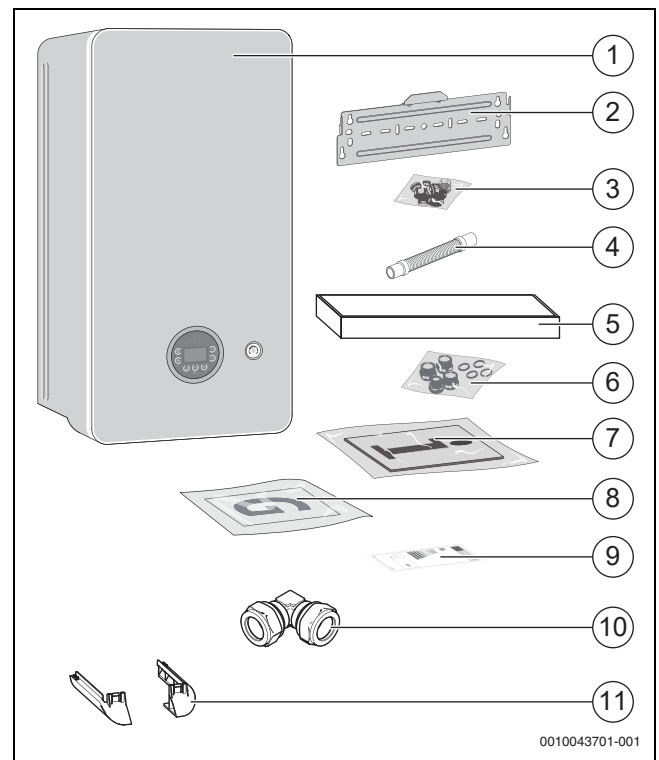

Fig. 1

- [1] Wall mounted gas-fired condensing combi appliance.
- [2] Wall mounting bracket.
- [3] Fittings pack.
- [4] Condensate hose connector.
- [5] Valves set.
- [6] Compression fittings set.
- [7] Literature pack:
 - Installation and Maintenance Instructions,
 - User Instructions,
 - Wall mounting template.
- [8] Guarantee card.
- [9] ErP label.
- [10] PRV compression elbow.
- [11] Side panel infills.

3.2 Declaration of Conformity

The design and operating characteristics of this product comply with the British, European and supplementary national requirements.



The UKCA and CE markings declare that the product complies with all the applicable British and European legislation, which is stipulated by attaching these markings.

You can request the complete text of the Declaration of Conformity from the UK address indicated in this document.

3.3 Simplified UK/EU Declaration of conformity regarding radio equipment

Bosch Thermotechnik GmbH hereby declares, that the product Greenstar 2000 described in these instructions complies with the Directive UK S.I. 2017/1206 (UK) 2014/53/EU.

You can request the complete text of the UK/EU Declaration of Conformity from the UK address indicated in this document.

3.4 Regulations

In order to ensure installation and operation of the product in accordance with the regulations, please observe all the applicable national and regional regulations as well as all technical rules and guidelines.

You can find a list of the most relevant British and European directives and regulations in the table below.

EU legislation	UK legislation
Electromagnetic Compatibility - Directive 2014/30/EU	Electromagnetic Compatibility Regulations 2016
Low Voltage Directive 2014/35	Electrical Equipment (Safety) Regulations 2016
Radio Equipment - Directive 2014/53/EU	Radio Equipment Regulations 2017
Pressure Equipment - Directive 2014/68/EU	Pressure Equipment (Safety) Regulations 2016
Gas Appliances - Regulation (EU) 2016/426	Regulation 2016/426 on gas appliances as brought into UK law and amended
Machinery Directive 2006/42/EC	Supply of Machinery (Safety) Regulations 2008
Ecodesign Directive 2009/125/EC	The Ecodesign for Energy-Related Products Regulations 2010
Energy Labelling Regulation (EU) 2017/1369	Energy Labelling Regulation (EU) 2017/1369 (as retained in UK law and amended)
Restriction of the Use of certain Hazardous Substances in Electrical and Electronic Equipment (RoHS) - Directive 2002/95/EC	The Restriction of the Use of Certain Hazardous Substances in Electrical and Electronic Equipment Regulations 2012
European Directive 2012/19/EC on old electronic and electrical appliances	(UK) Waste Electrical and Electronic Equipment Regulations 2013 (as amended)

Table 2

3.5 Appliance type overview

These appliances are for use with:

- Natural Gas or LPG (Cat.II 2H3P type C13, C33 & C53)

This document refers to the following appliance types:

Appliance type	Part number	Gas Council number
GR2301iW 25 C NG	7 736 902 326	47-800-34
GR2301iW 30 C NG	7 736 902 325	47-800-36
GR2301iW 25 C LPG	7736 902 328	47-800-35
GR2301iW 30 C LPG	7736 902 327	47-800-37

Table 3 Type overview

The name of the appliance consists of the following parts:

- GR2301iW : Type name
- 25 or 30: Hot water output in kW
- C: Combi appliance
- NG: Gas type (Natural Gas)
- LPG: Gas type (Liquid Petroleum Gas)

3.6 Product identification

Data plate

The data plate contains performance data, approval data and the serial number of the product.

The position of the data plate can be found in the product overview in this chapter.

Additional type plate

The additional type plate contains information on the product name and the most important product data.

It is located in an easily accessible place on the outside of the product.

3.7 Pipe work positions and flue outlet

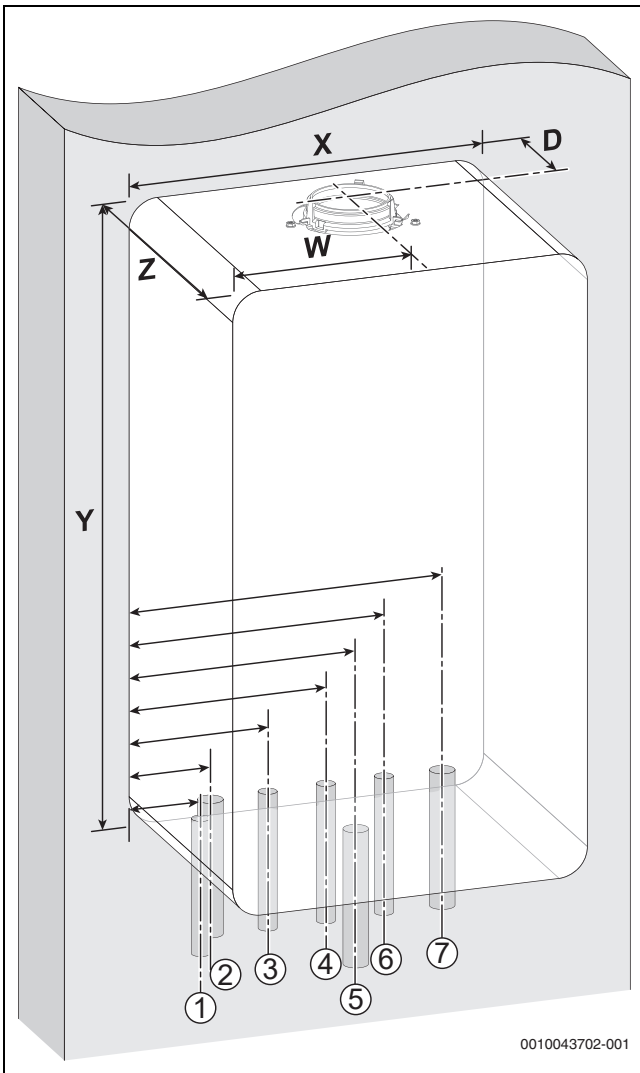

Fig. 2 Pipe and flue outlet dimensions

	Description	Dimensions (mm)
X	Appliance width	400
Y	Appliance height	724 ¹⁾
Z	Appliance depth	300
W	Flue centre from appliance left side	200
D	Flue centre from rear of appliance	125

1) Side panel height = 710mm

Table 4 Appliance and flue outlet dimensions

#	Function	From left case edge	Diameter of pipe
1	Condensate Hose Outlet	33 mm	21,5 mm • Rubber push fit connection
2	CH Flow	70 mm	22 mm • Compression fitting (via isolation valve)
3	DHW Outlet	135 mm	15 mm • Compression fitting (via adaptor)
4	Gas	200 mm	22 mm • Compression fitting (via isolation valve)

#	Function	From left case edge	Diameter of pipe
5	PRV Outlet	189 mm	15 mm • Compression elbow
6	DCW Inlet	265 mm	15 mm • Compression fitting (via isolation valve)
7	CH Return	330 mm	22 mm • Compression fitting (via isolation valve)

Table 5 Pipe dimensions



For servicing purposes, keep condensate and pressure release valve discharge pipes away from other hydraulic components.

3.8 Product overview

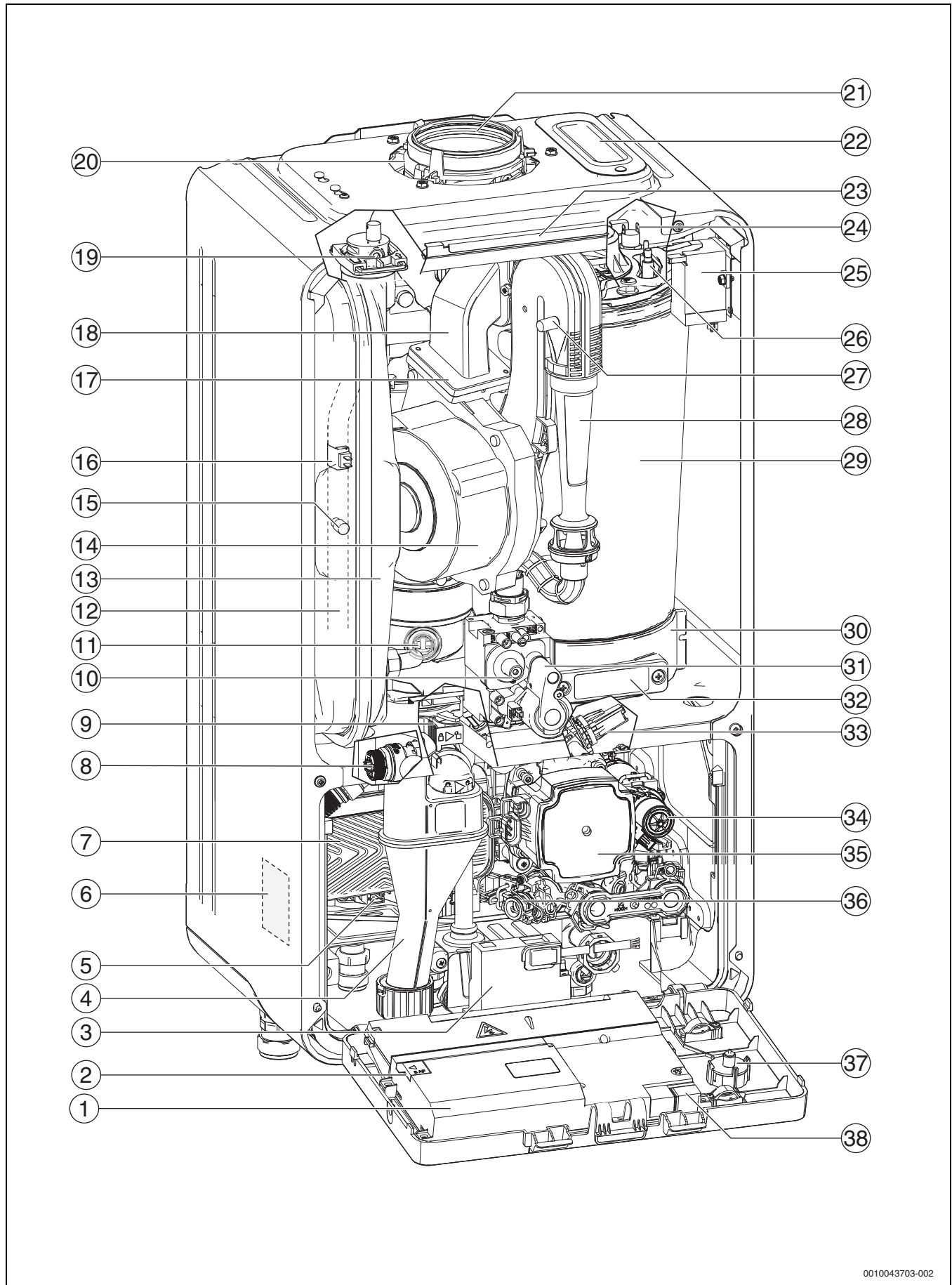

0010043703-002

Fig. 3 Product overview

Legend to figure 3:

- [1] Control unit
- [2] Fuse (replacement)
- [3] KEY accessory housing (wireless gateway)
- [4] Condensate trap
- [5] DHW temperature sensor
- [6] Data plate
- [7] Plate heat exchanger
- [8] Pressure relief valve (heating circuit)
- [9] Condensate trap locking mechanism
- [10] Gas supply pressure test point
- [11] Flue gas temperature limiter
- [12] Heating flow
- [13] Expansion vessel
- [14] Fan
- [15] Schrader valve
- [16] Flow temperature sensor
- [17] Air-gas manifold with non-return valve
- [18] Zero flow sensor
- [19] Automatic air vent
- [20] Combustion air intake
- [21] Flue connection
- [22] Inspection/Heat exchanger cleaning access
- [23] Front cover bracket
- [24] Heat exchanger temperature limit sensor
- [25] Ignition transformer
- [26] Electrode
- [27] Fan pressure test point
- [28] Gas-air mixing chamber
- [29] Primary Heat Exchanger
- [30] Condensate sump
- [31] Gas valve
- [32] Heat exchanger sump cover
- [33] System pressure sensor
- [34] Diverter valve
- [35] Heating pump
- [36] Flow turbine
- [37] Pressure gauge
- [38] Position for code plug (not supplied)

3.9 Product data for energy consumption

The product data on energy consumption can be found in the operating instructions for the user.

3.10 Standard accessories
3.10.1 Appliance accessories

Part number	Description
7 733 600 266	Greenstar System filter (22mm mini)
7 733 600 236	Greenstar System filter (22mm)
7 733 600 237	Greenstar System filter (28mm)
7 733 600 476	Greenstar System filter brass (22mm)
7 716 192 746	Worcester CondenseSure
7 716 192 610	Keyless filling link
7 733 600 091	Heat exchanger cleaning kit
7 736 902 357	Low NOx code plug kit 25kW
7 736 902 355	Low NOx code plug kit 30kW
7 736 902 372	DHW pre-heat kit
7 736 900 525	Greenstar Xtra FGHR
7 736 902 361	Spacer Frame (70mm)
7 736 902 512	Vertical piping kit

Table 6 Appliance accessories

3.10.2 Programmer/timer accessories

The programmers/timers listed can be used with the appliances stated on the front of this manual.

Part number	Description
7 733 600 332	MT20 mechanical timer
7 733 600 333	MT20RF mechanical thermostat
7 738 110 054	Sense I
7 738 111 064	Sense II (including weather sensor) ¹⁾
7 738 112 324	Comfort+ II RF ¹⁾
7 738 112 338	Comfort+ stat RF ²⁾

1) Preheat time control available.

2) Must be used with an external proprietary 230V timer.

Table 7 Control accessories

Bosch EasyControl smart control system

Part number	Description
7 736 701 341	EasyControl (white) ¹⁾
7 736 701 392	EasyControl (black) ¹⁾
7 738 112 351	EasyControl RF Key
7 736 701 555	EasyControl TRV set (white)
7 736 701 556	EasyControl TRV set (black)
8 750 000 270	EasyControl smart TRV (individual)

1) Preheat time control available.

Table 8 EasyControl accessories

Basic weather compensation sensor

Outdoor weather sensor (to activate on-board simple Weather Compensation).

Part number	Description
7 716 192 764	Outdoor weather sensor

Table 9 Control accessories



The outdoor weather sensor is supplied with the Sense II. It is optional with the Comfort+ II RF. Weather compensation is available with the EasyControl without the need for a physical outdoor sensor, however, it can improve control accuracy for installations in isolated micro-climates or highly sheltered locations such as valleys.

4 Pre-Installation

NOTICE

Risk of damage to system or appliance!

Before installation

- ▶ All the following Pre-Installation sections must be read and requirements met before starting appliance or flue installations.

4.1 System preparation

4.1.1 Artificially softened water

The heating system must not be filled with water which has been treated using an ion exchange (salt based) water softener. Where these water softeners are installed, a permanent untreated water supply should be provided to maintain pressure in the heating system.

A bypass must be provided at the water softener to comply with BS:14743. Where a permanent untreated supply cannot be provided, the system must be initially filled using the bypass provided at the water softener. Occasional topping up of the system with artificially softened water is acceptable. Inhibitor must be added to the system. The pH levels must be between 6.5 and 8.0 at the time of commissioning. When a permanent untreated supply is not provided to the heating system filling point, the pH levels must be checked annually and recorded in the service record.

NOTICE

Risk of damage to appliance!

- ▶ The heating system must not be filled with water which has been treated using an ion exchange water softener.
- ▶ If the system is partially drained for maintenance or repair work, the system must be refilled by utilising the bypass valve at the water softener. The pH and inhibitor levels should be checked.

4.1.2 Water systems and pipework

Primary system plastic pipework:

- Any plastic pipework must have a polymeric barrier, complying with BS 7921 and installed to BS 5955 with 600mm (minimum) length of copper connected to the appliance.
- Plastic pipework used for under-floor heating must be correctly controlled with a thermostatic blending valve limiting the temperature of the circuits to approximately 50°C with 1000mm (minimum) length of copper or steel pipe connected to the appliance.

Primary system/connections/valves:

- Do not use galvanised pipes or radiators.
- All system connections, taps and mixing valves must be capable of sustaining a pressure of 3 bar.
- Radiator valves should conform to BS 2767:10.
- All other valves should conform to BS 1010.
- It is best practice to fit Thermostatic Radiator Valves (TRV's) to all radiators, except the area where the room thermostat is sited which must be fitted with lockshield valves that are left open.
- **The circulating pump speed is fixed therefore as system circulation can be significantly adjusted or stopped by TRV's or zone valves, a system bypass must be installed to give at least a 3 metre circuit when activated.**
- Drain cocks are required at all the lowest points on the system.
- Air vents are required at all high points on the system.

Showers/Bidets:

- If a shower head can be immersed in water or comes closer than 25mm from the top edge of a bath or shower tray spill-over level then an anti-siphon device must be fitted to the shower hose.
- Bidets with direct hot and cold mains water can be used (with the approval of the local water authority) and must be the over rim flushing type with shrouded outlets to prevent the fitting of hand held sprays.

Hot water:

- Taps and mixing valves must be capable of sustaining a pressure up to 10 bar.
- Hot water temperature and flow rate are affected by the size and insulation of pipework making up the distribution system and are controlled by the hot water tap and the water main inlet pressure. A mixing valve can be fitted if a more permanent temperature setting is required.
- If using more than one outlet at once causes water flow starvation, fit flow balancing valves or Ball-O-Fix valves to the appropriate outlets.
- Thermostatic mixing valves (TMVs) must be fitted at the point of use as specified in G3 of the building regulations and if specific, accurate temperature control is required by the user.

Primary system considerations - Combi & System appliances

Sealed system

- The CH sealed system must be filled using a WRAS approved filling loop or comply with examples in section 4.1.4 "System fill".
- Where the system volume is more than 100 litres or exceeds 2.5 bar at maximum heating temperature an additional expansion vessel [2] must be fitted as close as possible to the appliance in the central heating return.
- Pressurise the extra expansion vessel [2] to the same value as the built-in expansion vessel [1] (default pre-charge pressure is 0.75 bar).

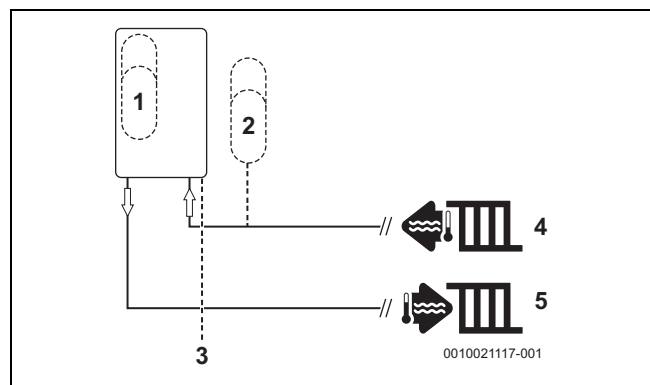

Fig. 4 Additional expansion vessel

- [1] Appliance expansion vessel
- [2] Additional expansion vessel
- [3] Pressure relief discharge
- [4] Heating return
- [5] Heating flow

To determine whether an additional expansion vessel is required: Follow the steps below:

- ▶ Calculate the total system volume (litres).
 - Plot a line vertically on the chart (→ Fig. 5).
- ▶ Determine the central heating maximum operating flow temperature.
 - Plot a line horizontally on the chart (→ Fig. 5).
- ▶ Determine the pre-charge in the expansion vessel based on static head, 1 metre = 0.1 bar.
 - Static head should be measured between the expansion vessel and the highest point on the system (top of the highest radiator).
- ▶ Select a curve from the key below (1-5).
- ▶ System pressure should be set at 0.1 - 0.25 bar higher than the vessel pre-charge.
 - It must be at least to the minimum on appliances with an analogue gauge.
 - Minimum pressure settings may need to be adjusted to suit on, appliances with a digital gauge, in the applicable menu function.
 - Intelligent filling settings may need to be adjusted to suit on, appliances with the automatic filling accessory, in the applicable menu function.

If the dissected lines are in area A then no additional expansion is required.

If the dissected line is in are B then an additional expansion vessel must be installed (→ Fig. 4).

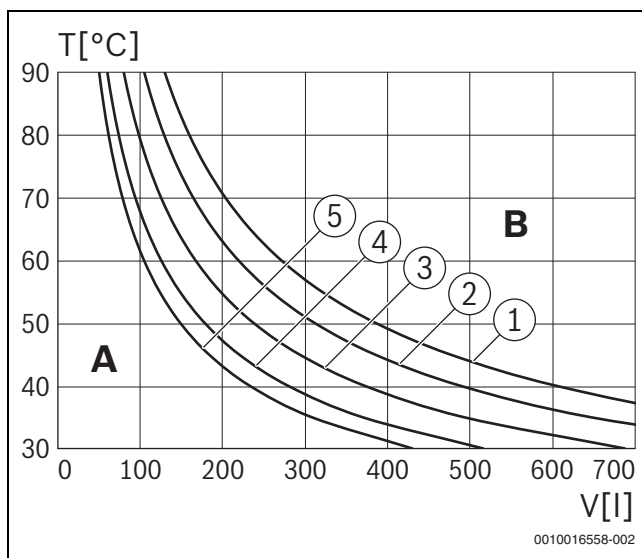

Fig. 5 Curves for the expansion vessel

- 1 Pre-charge pressure 0.5 bar (minimum)
- 2 Pre-charge pressure 0.75 bar
- 3 Pre-charge pressure 1.0 bar
- 4 Pre-charge pressure 1.2 bar
- 5 Pre-charge pressure 1.3 bar
- A Operational capacity of the expansion vessel (left of the relevant curve)
- B Additional expansion vessel required (right of the relevant curve)
- T Maximum operating temperature [°C]
- V Total System Volume [l]



The default pre-charge pressure for the expansion vessel is 0.75 bar

4.1.3 System layouts examples

Sealed primary system - Single central heating circuit:

Typical primary system example

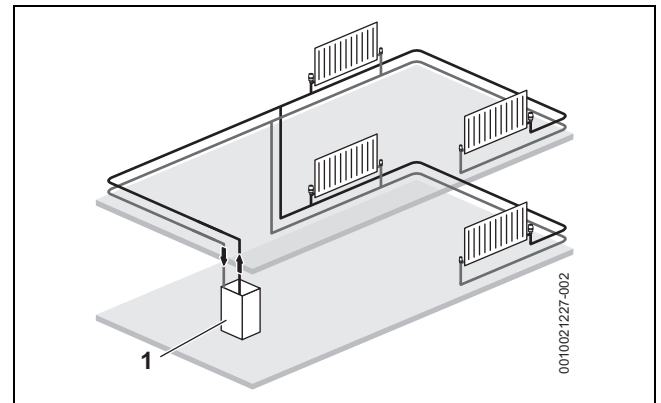

Fig. 6 Single central heating circuit example

- [1] Appliance

Sealed primary system - 2 x central heating zones:

- Requirement for new builds if the floor area of a property is over 150m².

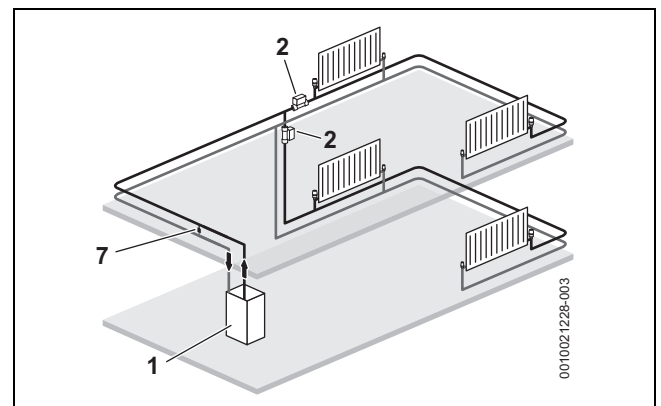

Fig. 7 Separated heating zones

- [1] Appliance
- [2] Zone valves
- [7] Auto bypass across flow and return to be at least 1.5m away from the appliance (3m loop of pipe)

4.1.4 System fill

Integral filling link

- An optional filling link accessory is available to fill the system.
 - Refer to filling link instructions for fitting and operation.

Filling primary sealed systems

NOTICE

Filling the primary sealed system

The system must not be filled with salt based softened water.

- ▶ Ensure the primary water filling point uses an untreated cold water connection from the mains supply, before a water softener.
-
- Filling the system must comply with one of the following methods shown.
 - The filling point must be at low level and must never be a permanent connection to the mains water supply.
 - Filling loops must be WRAS approved.
 - If the external filling link is sited away from the appliance, then a pressure gauge should be installed at the filling point.



The pressure shown on the gauge may differ from that shown on the digital display. Final system pressure adjustments must be made whilst referencing the digital display.

External filling loop

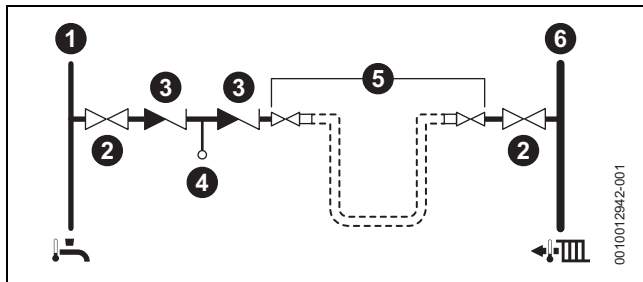

Fig. 8 External filling loop system fill example

- [1] Cold mains inlet pipe
- [2] Stop valve
- [3] Check valve
- [4] Test point
- [5] Hose union
- [6] Central heating flow pipe

4.2 Mains supply

4.2.1 Electrical supply

- Supply: 230V AC - 50 Hz
- This appliance must **not** be connected to a three phase supply.
- The wiring between the appliance and the electrical supply must comply with the latest IET wiring regulations that apply to wiring a fixed appliance for Class 1 equipment.
- The correct type of RCD must be employed where additional protection is required that is suitable for a low energy DC modulating pump according to IET wiring regulations.
- External 3 A fuse to BS1362.
- The appliance must be earthed.
- Cable: PVC insulated 0.75mm² (24 x 0.2mm) temperature rated to 90 °C, to BS EN50525.
- Any additional components that are connected to the appliance with mains electrical supply must not have a separate supply.
- Additional equipment wired to the appliance must comply with the latest IET wiring regulations.
- Appliance protection rating - IPX4D

4.2.2 Gas supply

- Appliances using Natural Gas (NG) must be connected to a governed meter.
- Appliances using Liquid Petroleum Gas (LPG) must be connected to a regulator.
- Installation and connection of the gas supply to the appliance must be in accordance with the latest version of BS6891.
- Gas pipe sizing should be calculated to ensure no more than the permitted mbar drop between the meter to the appliance inlet. (→ chapter 6).
- The meter and pipe work to the meter must be checked, preferably by the gas supplier. This is to ensure that the equipment is in good working order and can meet the gas flow and pressure requirements, in addition to the demand from any other appliance being served.

Pipe sizing (NG & LPG)



Gas pipe work:

- ▶ Gas installation pipe work must be designed to ensure the pressure loss between the meter outlet (NG) or storage and regulator (LPG) and the inlet to each appliance does not exceed 1mbar (NG) or 2.5mbar (LPG) → table 25 "Allowed mbar pressure drop".

Basic pipe sizing calculation



Basic pipe sizing calculation.

- ▶ **This method is only a guide - for more complex design please refer to latest version of BS6891 and training given in ACS.**

Natural Gas (NG):

Discharge rates for copper tube with 1mbar differential pressure between the ends for Natural Gas.

Discharge rates for Natural Gas (m ³ /hr) with straight horizontal copper tube					
Pipe Length (m)	Discharge m ³ /hr	Pipe Size (mm)			
		15	22	28	35
3		2.9	8.7	18	32
6		1.9	5.8	12	22
9		1.5	4.6	9.4	17
12		1.3	3.9	8	15
15		1.1	3.4	7	13
20		0.95	2.9	5.9	11
25		0.92	2.5	5.2	9.5
30		0.88	2.3	4.7	8.5

Table 10 Natural Gas



Natural Gas:

- ▶ When using this table to estimate the gas flow rate in pipe work of a known length, the effective length will be increased by 0.5m for each 90° elbow and tee fitted and by 0.3m for each 45° bend.

Liquid Petroleum Gas (LPG)::

Discharge rates for copper tube with 2.5mbar differential pressure between the ends for LPG.

Discharge rates for LPG (m ³ /hr) with straight horizontal copper tube						
Tubing length (m)	Outside diameter					
	15mm		22mm		28mm	
	kW	m ³ /hr	kW	m ³ /hr	kW	m ³ /hr
3	38.4	1.49	207	8.01	412	15.92
6	26.1	1.01	135	5.21	230	8.86
9	20.5	0.79	108	4.19	215	8.33
12	17.9	0.70	94	3.62	187	7.25
15	15.5	0.60	82	3.20	168	6.51
18	13.5	0.53	74	2.86	145	5.61
21	12.9	0.50	67	2.58	135	5.24
24	12.0	0.47	61	2.58	126	4.87

Table 11 Liquid Petroleum Gas (LPG)



Liquid Petroleum Gas (LPG):

- ▶ When using this table to estimate the gas flow rate in pipework of a known length, the effective length will be increased by 0.6m for each 90° elbow or tee used and by 0.3m for each 45° bend or straight coupler used.

4.2.3 Gas supply

- Appliances using Natural Gas (NG) must be connected to a governed meter.
- Installation and connection of the gas supply to the appliance must be in accordance with the latest version of BS6891.
- Gas pipe sizing should be calculated to ensure no more than the permitted mbar drop between the meter to the appliance inlet. (→ chapter 6).
- The meter and pipe work to the meter must be checked, preferably by the gas supplier. This is to ensure that the equipment is in good working order and can meet the gas flow and pressure requirements, in addition to the demand from any other appliance being served.

Pipe sizing (NG)



Gas pipe work:

- ▶ Gas installation pipe work must be designed to ensure the pressure loss between the meter outlet (NG) → table 25 "Allowed mbar pressure drop".

Basic pipe sizing calculation



Basic pipe sizing calculation.

- ▶ **This method is only a guide - for more complex design please refer to latest version of BS6891 and training given in ACS.**

Natural Gas (NG):

Discharge rates for copper tube with 1mbar differential pressure between the ends for Natural Gas.

Discharge rates for Natural Gas (m ³ /hr) with straight horizontal copper tube					
Pipe Length (m)	Discharge m ³ /hr	Pipe Size (mm)			
		15	22	28	35
3		2.9	8.7	18	32
6		1.9	5.8	12	22
9		1.5	4.6	9.4	17
12		1.3	3.9	8	15
15		1.1	3.4	7	13
20		0.95	2.9	5.9	11
25		0.92	2.5	5.2	9.5
30		0.88	2.3	4.7	8.5

Table 12 Natural Gas



Natural Gas:

- ▶ When using this table to estimate the gas flow rate in pipe work of a known length, the effective length will be increased by 0.5m for each 90° elbow and tee fitted and by 0.3m for each 45° bend.

4.2.4 Water supply

Use in hard water areas:

Normally there is no need for water treatment to prevent scale formation as the maximum temperature of the DHW heat exchanger is limited by the electronic control.

In areas where temporary water hardness exceeds 200ppm, consideration may need to be given to the fitting of a scale prevention device. In such circumstances, the advice of the local water authority should be sought.

Keyless filling link accessory



Minimum static pressure.

- ▶ A minimum static cold water mains pressure of 1.75bar is recommended for correct operation of the Keyless filling link.

Water mains pressure:

- Minimum mains water pressure, for maximum performance refer to section 13.1 "Technical data".
- Maximum mains fed water static pressure is 10 bar. If necessary fit a pressure reducing valve.

NOTICE

Non-return, back flow prevention devices (including those associated with water meters) fitted to the mains water supply can cause a pressure build up which could damage the boiler and other household appliances.

NOTICE

Non-return valves in the cold water feed system.

If a non-return valve is fitted on the mains inlet, then pressure can increase significantly over normal standing pressure when the appliance carries out a DHW preheat or due to fast acting valves closing on other appliances/outlets.

- ▶ To ensure water pressure stays at a level that will not damage the boiler or other household appliances, we would recommend on installations where standing pressure exceeds 3bar, that a 3 bar pressure reducing valve and mini expansion vessel are fitted.
- Where the mains water supply has a non-return, back flow prevention valve fitted, a mini expansion vessel [3] should be connected to the mains water inlet pipe [1] between the non-return valve [2] and the appliance [4] as shown below.

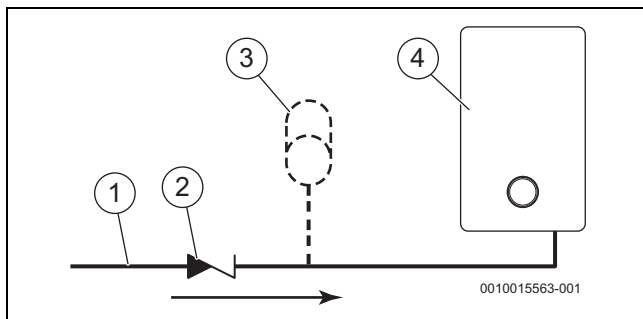

Fig. 9 Mini expansion vessel location

- [1] Mains water inlet pipe
- [2] Non-return valve
- [3] Mini expansion vessel - part no. 7 716 192 105
- [4] Appliance

4.3 Appliance location and clearances

4.3.1 Appliance location

- Follow local regulations for the location within the property that the appliance is to be installed.
- This appliance is only suitable for installing internally within a property at a suitable location onto a flat, fixed rigid surface capable of supporting the appliance weight.
- The appliance is not suitable for external installation.
- Protect installation area against dust and moisture.



No surface protection is required against heat transfer from the appliance.



DANGER

Danger from explosive and flammable materials:

Storage of explosive and flammable materials.

- ▶ Do not store flammable materials (paper, curtains, clothing, primer, paint, ...) in proximity to the appliance.



WARNING

Risk of injury due to damage to the appliance

- ▶ The appliance must not be sited in such a position that some or all of the underside of the appliance is closer than 760mm above a permanently fixed hob.
- ▶ Reasonable care should be taken to ensure the appliance is not installed directly above where other heat-producing kitchen appliances such as portable hot plates, toasters and kettles are likely to be sited.

NOTICE

Damage to appliance:

Contaminated combustion air.

- ▶ Do not use any cleaners containing chlorine or hydrogen halide (i.e. spray cans, primers, cleaners, paint and glue).
- ▶ Do not store or use these substances in the appliance or room.
- ▶ Avoid the build-up of dust.

NOTICE

Damage to appliance:

Extreme temperatures may cause damage to the heating system.

- ▶ Ensure the appliance location's ambient temperature is above 0 °C and below 50°C.

NOTICE

Damage to system:

The heating system pipe work can be damaged by frost if installed in an internal unheated area, such as a loft, basement or garage.

The appliance internal frost protection only monitors the system water temperature within the appliance to provide protection for the appliance.

- ▶ System frost protection can be achieved when using either Worcester weather-compensating controls or via a hard-wired thermostat when using external 230v controls (refer to figure 60, page 45).
- ▶ The system pipe work in the internal unheated area should be insulated.
- ▶ If the appliance is to be shut down for an extended period, drain the central heating system.



The appliance must be installed where:

- ▶ The area is well lit, allowing users to clearly see the appliance to carry out any work or checks.
- ▶ An engineer can gain clear and safe access to work on the product or component, including making adequate provision for visual inspection of flues in voids.
- ▶ The homeowner can gain clear and safe access to the controls or to check, top up or reset the appliance.
- ▶ Roof space installations must fully conform to BS 6798: roof space installations.
- ▶ Products in roof spaces must have permanent fixed lighting, a permanent fixed retractable ladder and a fixed floor area sufficient to allow access for normal use and servicing around the product and between the product and the access hatch.
We would also recommend that a remote pressure gauge and filling loop are sited where the customer can gain easy access to assist with checking and topping up.

4.3.2 Rooms containing a bath or shower



CAUTION

Risk of electric shock

- ▶ Any switch or appliance control using mains electricity must not be within reach of a person using the bath or shower.
-
- In all cases the installation **must be in accordance with the latest amendments to the latest edition of the IET Wiring Regulations (BS7671)**.
 - Check the IP rating of any control units to be used on this appliance.
 - Circuit breaking devices should be used in accordance with the regulations.
 - Figure 10 is for guidance only.

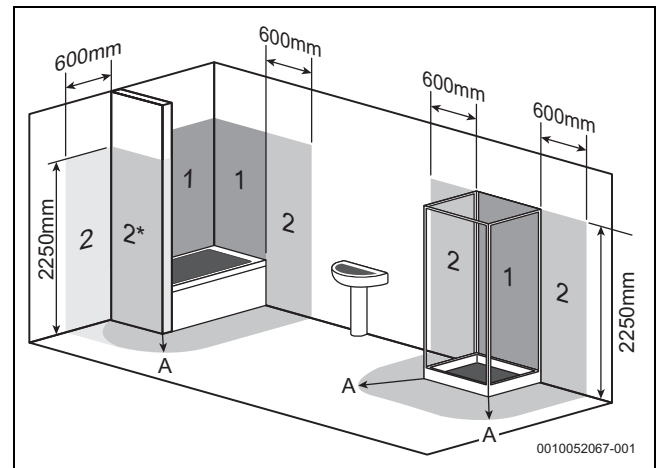

Fig. 10 Bathroom installations

- [1] Zone 1
 - [2] Zone 2
 - [2*] Without the end wall, zone 2 must extend 600mm from the bath
 - [A] 600mm radius from the bath or shower
- Appliance protection rating - IPX4D

4.3.3 Appliance clearances

- The following details cover the installation, service and maintenance clearances for the appliance.



Risk of damage to appliance or property

The appliance will overheat if the clearance space around the appliance is restricted by objects.

- Do not restrict this space with the addition of cupboards, shelves etc. next to or around the appliance.
- Do not store any combustible materials on or next to the appliance, such as clothes, towels, paper or plastic bags.

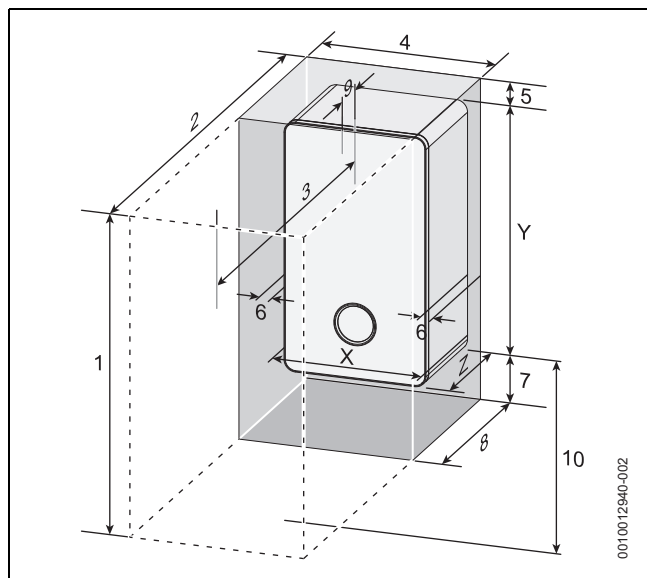

Fig. 11 Appliance minimum clearances

Minimum clearances		
	Description	Dimensions (mm)
X	Appliance width	400
Y	Appliance height	724 ¹⁾
Z	Appliance depth	300
Installation/Maintenance		
1	Overall clearance height	1094/1134 ²⁾
2	Overall clearance depth	900 ³⁾
3	In front of appliance	600 ³⁾
4	Overall clearance width	410
5	Above the appliance	170/210 ²⁾
6	Either side of appliance	5
7	Below the appliance	200
8	Compartment depth	320 ⁴⁾
9	Appliance to removable door	20

- Side panel height = 710mm
- Height for either 60/100 flue or 80/125 flue
- This can be reduced (refer to Reduced front maintenance minimum clearances).
- Clearance to a combustible material

Table 13 Appliance minimum clearances

Reduced front maintenance minimum clearances

The front servicing clearance for this appliance can be reduced to 450mm.

For installations with a front servicing clearance less than 600mm (minimum of 450mm), the following additional criteria must be achieved.

- The bottom of the appliance case must be between 1000mm and 1500mm from the floor.
- There must be at least 450mm clearance in front of the appliance to floor level. Anything sited below the appliance must not protrude into this clear space.
- There must be at least 200mm clearance to any structure which is sited below the appliance.
- There must be at least 300mm clear space to either the left hand or right hand side of the appliance. This clear space must be from the required clear height above the appliance to floor level.
 - This clearance will not apply if the appliance is sited within 300mm of a door way and the door frame is the only obstruction.



Minimum clearances must be observed to any obstruction/ surface, (dark shaded areas, figures 12 and 13).

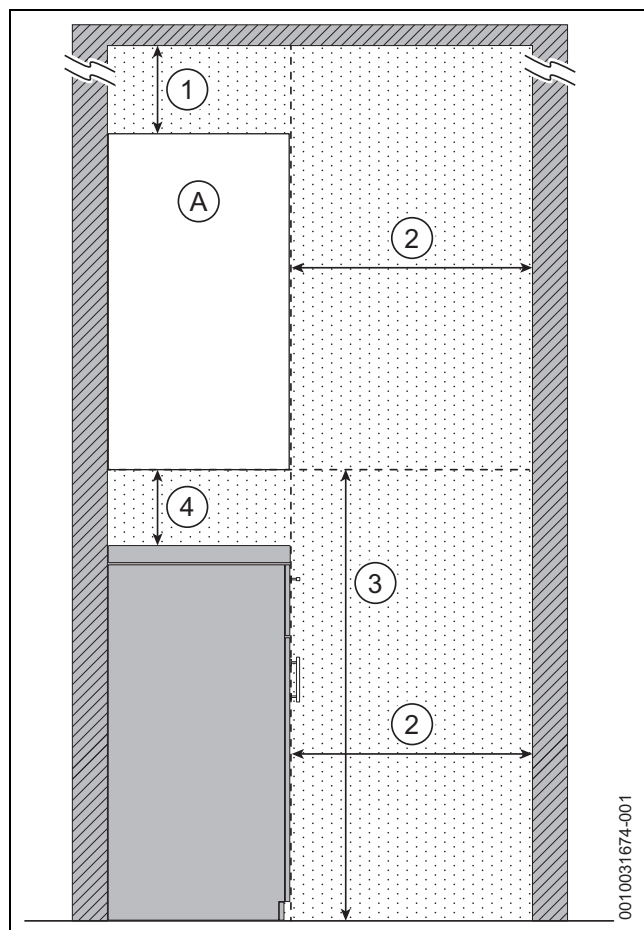

Fig. 12 Reduced front maintenance clearances - Side view

- [A] Appliance.
- [1] Above appliance - Same clearance required as for standard clearances of 60/100 flue or 80/125mm flue.
- [2] In front of appliance - Minimum 450mm.
- [3] Bottom of appliance to the floor - 1,000 - 1,500mm.
- [4] Below appliance - 200mm.

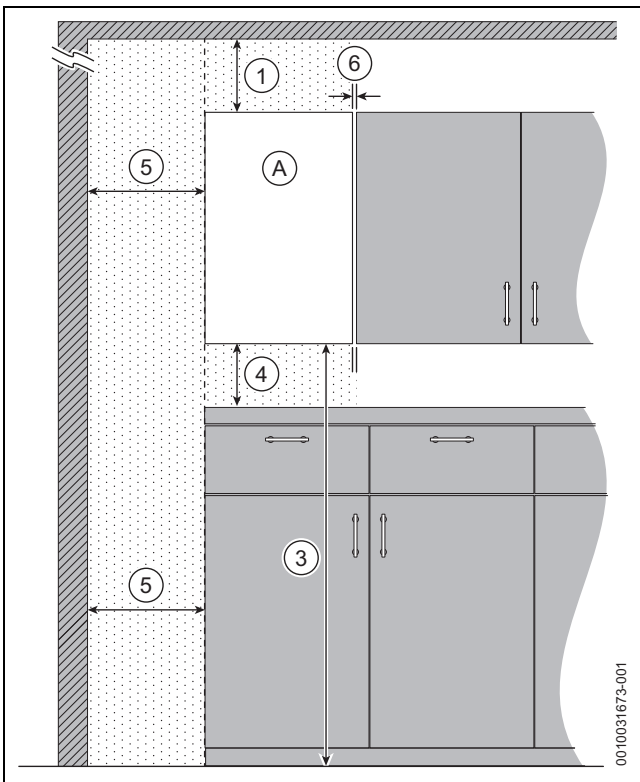

Fig. 13 Reduced front maintenance clearances - Front view

- [A] Appliance.
- [1] Above appliance - Same clearance required as for standard clearances of 60/100 flue or 80/125mm flue.
- [2] To the right of appliance - Minimum 5mm.
- [3] Bottom of appliance to the floor - 1,000 - 1,500mm.
- [4] Below appliance - 200mm.
- [5] One side of appliance - Minimum 300mm.
- [6] One side of appliance - Minimum 5mm.

Appliances in compartments

Follow the latest requirements of BS6798 and BS5440 and note:

- Minimum clearances must be maintained.
- An access door is required to install, service and maintain the appliance and any ancillary equipment.
- If the appliance is installed in an unventilated airing/storage cupboard, there is no requirement to make a partition between the appliance and the storage space as long as the minimum clearances around the appliance are maintained.

4.4 Flue systems considerations

WARNING

Flue systems

Possible flue gas escape

- ▶ Use Worcester, Bosch Group approved Condensfit II flue systems only, no other manufacturer's flue have been tested or approved for use with Worcester, Bosch Group appliances.

Condensfit II

CAUTION

Concealed flue systems:

- ▶ Where a flue system is going to be concealed, provision must be made for service and inspection.
- ▶ Voids containing concealed flues must have at least one inspection hatch no less than 300mm square.
- ▶ Flue joints within the void must not be more than 1.5 metres from the edge of the inspection hatch.
- ▶ Inspection hatches should be located at changes of direction.
- ▶ If this is not possible, bends should be viewable from both directions.

i

Refer to the manual supplied with the Worcester, Bosch Group flue kit for complete installation instructions.

Flue kit part numbers

Part number	Flue Ø	Description
7 716 191 082	60/100	Telescopic horizontal flue kit
7 716 191 171	60/100	Extended telescopic horizontal flue kit
7 733 600 048	60/100	Horizontal high level telescopic flue kit
7 733 600 298	60/100	1050mm horizontal fixed flue kit
7 719 003 702	80/125	Telescopic horizontal flue kit
7 719 002 430	60/100	Vertical balanced flue kit
7 719 002 431	80/125	Vertical balanced flue kit

Table 14 Flue kit assembly part numbers

4.4.1 Flue length

Horizontal maximum flue lengths

Appliance	Flue length [L]	
	60/100	80/125
GR2301iW 25 C	12,000mm	21,000mm
GR2301iW 30 C	12,000mm	21,000mm

Table 15 Maximum flue lengths - Horizontal flues

Vertical maximum flue lengths

Appliance	Flue length [L]	
	60/100	80/125
GR2301iW 25 C	12,000mm	21,000mm
GR2301iW 30 C	12,000mm	21,000mm

Table 16 Maximum flue lengths - Vertical flues

Flue system bends

NOTICE

Effective flue lengths of bends:

Each bend used has an equivalent straight flue length.

► Refer to table 17.

Bend	Effective flue length	
	60/100	80/125
45°	0.5m	0.5m
90°	1.5m	1.5m

Table 17 Effective length of bends

4.4.2 Flue options

The systems have different maximum flue lengths, refer to the following example flue options for those maximum flue lengths.

Horizontal high level flue assembly

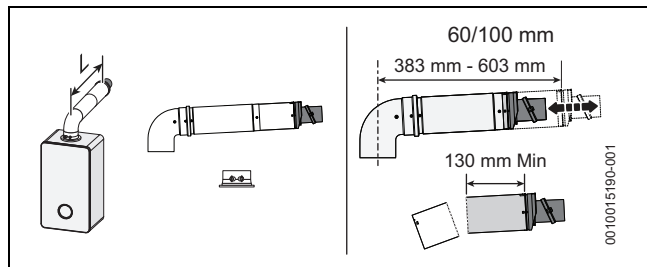

Fig. 14 Horizontal flue option

- Flue length [L] (initial bend included in length calculation)
 - 60/100 = 202 - 603mm
 - 80/125 = N/A

Telescopic horizontal flue assembly

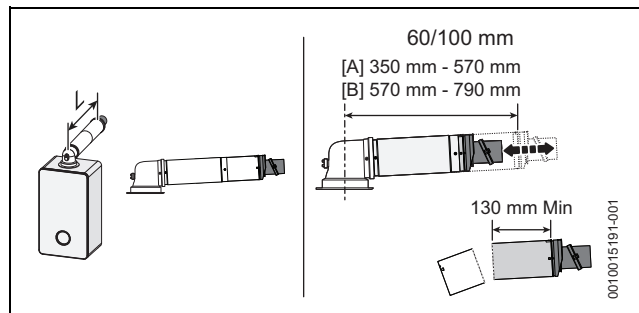

Fig. 15 Horizontal flue option

Telescopic horizontal flue assembly [A]

- Flue length [L] (adaptor bend included in length calculation)
 - 60/100 = 180 - 570mm
 - 80/125 = 405 - 600mm

Extended telescopic horizontal flue assembly [B]

- Flue length [L] (adaptor bend included in length calculation)
 - 60/100 = 570 - 790mm
 - 80/125 = N/A

Horizontal fixed length flue assembly

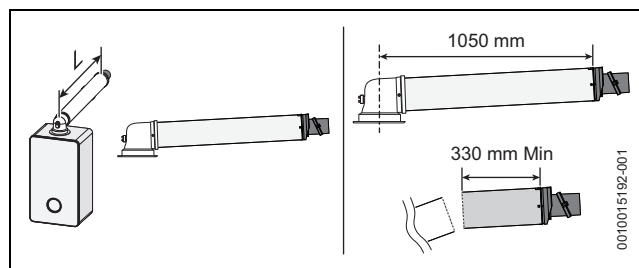

Fig. 16 Horizontal flue option

- Flue length [L] (adaptor bend included in length calculation)
 - 60/100 = 330 - 1,050mm
 - 80/125 = N/A

Extended horizontal flue

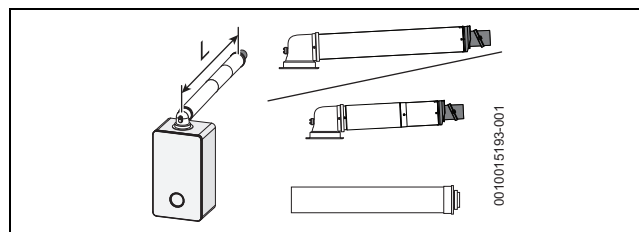

Fig. 17 Horizontal flue option

- Flue length [L] (adaptor bend included in length calculation)
 - Maximum flue length as stated in "Horizontal maximum flue lengths".

Horizontal flue with additional 90° elbow

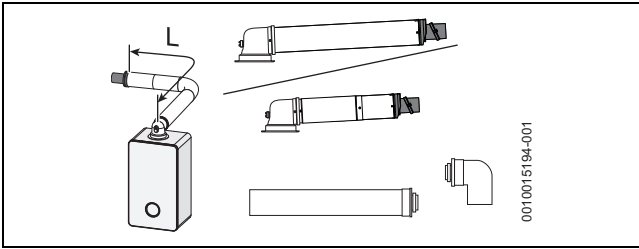

Fig. 18 Horizontal flue option

- Flue length [L] (adaptor bend included in length calculation)
 - Maximum flue length as stated in "Horizontal maximum flue lengths" minus the 90° bend equivalent straight flue length as stated in Table 17 "Effective length of bends".

Horizontal flue with additional 90° elbows

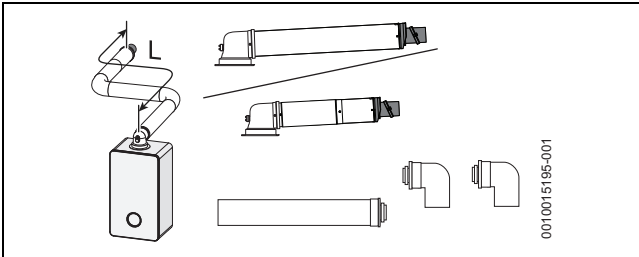

Fig. 19 Horizontal flue option

- Flue length [L] (adaptor bend included in length calculation)
 - Maximum flue length as stated in "Horizontal maximum flue lengths" minus 2 x 90° bends equivalent straight flue length as stated in Table 17 "Effective length of bends".

High level horizontal flue

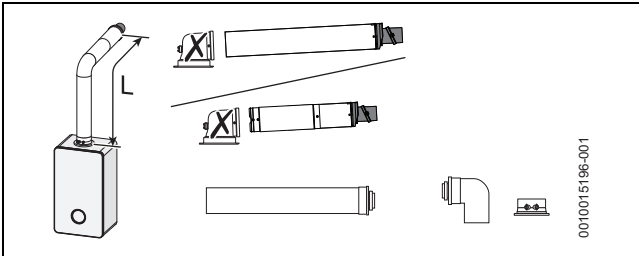

Fig. 20 Horizontal flue option

- Flue length [L] (initial bend included in length calculation)
 - Maximum flue length as stated in "Horizontal maximum flue lengths".

High level horizontal flue with additional 90° elbow

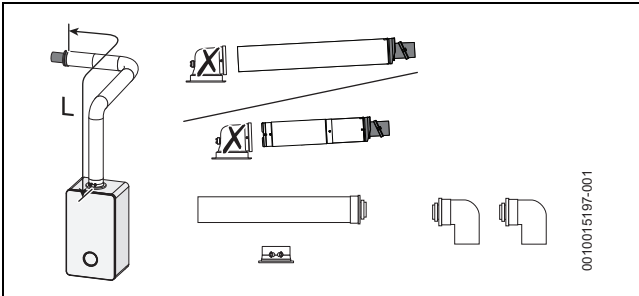

Fig. 21 Horizontal flue option

- Flue length [L] (initial bend included in length calculation)
 - Maximum flue length as stated in "Horizontal maximum flue lengths" minus the 90° bend equivalent straight flue length as stated in Table 17 "Effective length of bends".

High level horizontal flue with additional 90° elbows

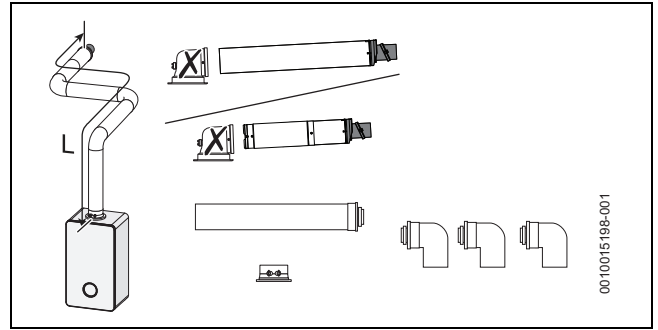

Fig. 22 Horizontal flue option

- Flue length [L] (initial bend included in length calculation)
 - Maximum flue length as stated in "Horizontal maximum flue lengths" minus 2 x 90° bends equivalent straight flue length as stated in Table 17 "Effective length of bends".

Vertical balanced flue assembly

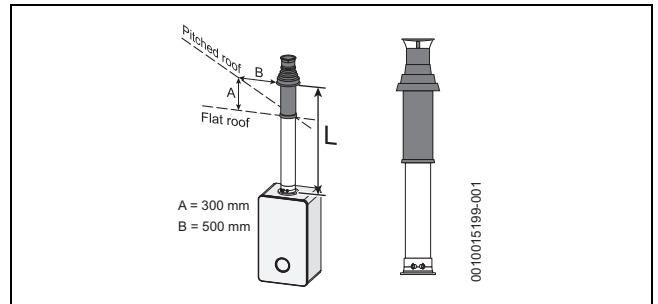

Fig. 23 Vertical flue option

- Flue length [L]
 - Maximum flue length as stated in "Vertical maximum flue lengths".

Vertical balanced flue with 90° elbow offset

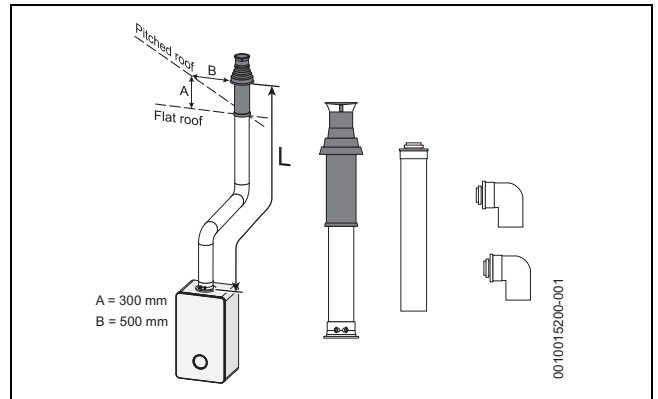

Fig. 24 Vertical flue option

- Flue length [L]
 - Maximum flue length as stated in "Vertical maximum flue lengths" minus 2 x 90° bends equivalent straight flue length as stated in Table 17 "Effective length of bends".

Vertical balanced flue with 45° elbow offset

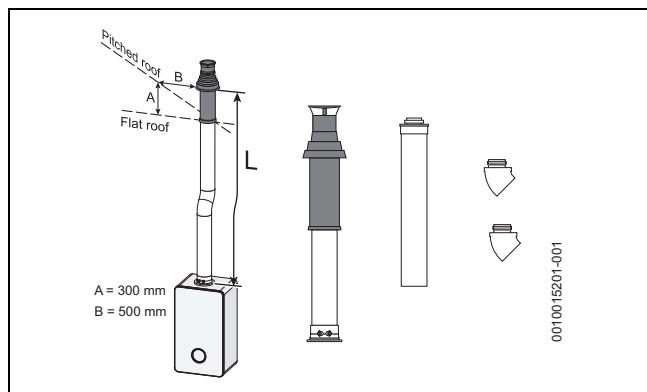

Fig. 25 Vertical flue option

- Flue length [L]
 - Maximum flue length as stated in "Vertical maximum flue lengths" minus 2 x 45° bends equivalent straight flue length as stated in Table 17 "Effective length of bends".

4.4.3 Plume management system

NOTICE

Plume management terminal:

- ▶ The plume management terminal must not be sited within 500mm of the air intake, and must not exceed the maximum straight length for a horizontal Ø 60/100mm flue with a 60mm plume management system.



Horizontal plume management runs

- ▶ The initial horizontal run from the terminal elbow must have a minimum 10° fall back, (stop tabs in the elbow prevent less than 10°) to the appliance for proper disposal of condensate.
- ▶ Any further horizontal runs after an elbow can be 3°.

WARNING

Minimum plume management length:

The minimum distance of 500mm must be maintained between air inlet and exhaust.

- ▶ Do not terminate the plume management inside the terminal exclusion zone (shaded area) shown in figure 26.

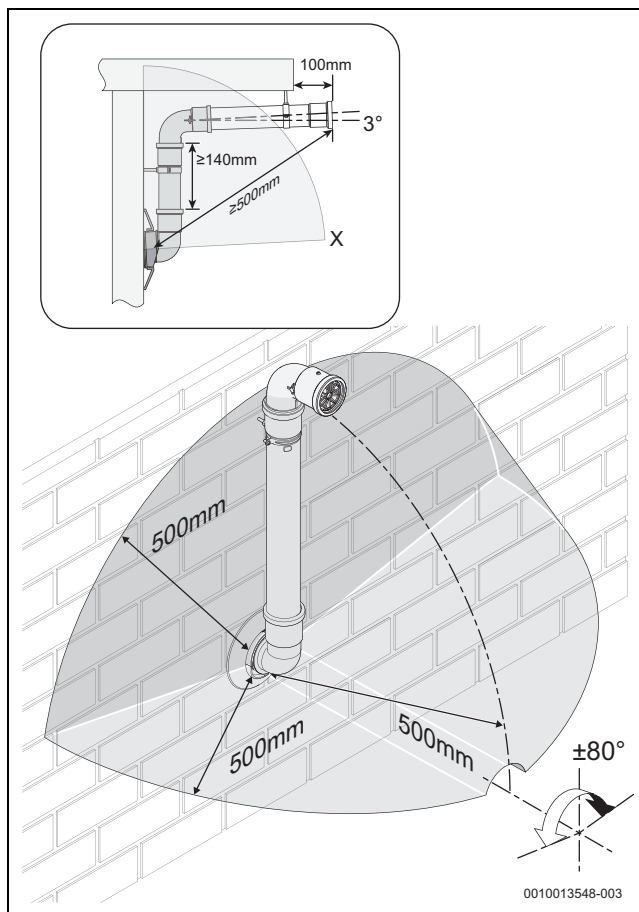

Fig. 26 Terminal exclusion zone

NOTICE

Cutting the 500mm pipe

- ▶ The Plume management extension kit contains the components required for such a configuration.

Plume management bends

NOTICE

Effective plume management lengths of bends:

- Each bend used has an equivalent straight plume management length.
- ▶ Refer to the table 18.

Bend	Effective plume management length
45°	0.75 metres
90°	1.5 metres

Table 18 Effective length of bends

The maximum flue length allowed for 0.5 m of plume is 9 m, each additional 1 m of plume reduces the flue length by 750 mm, up to a maximum of 4.5 m of plume management with 6 m of flue.

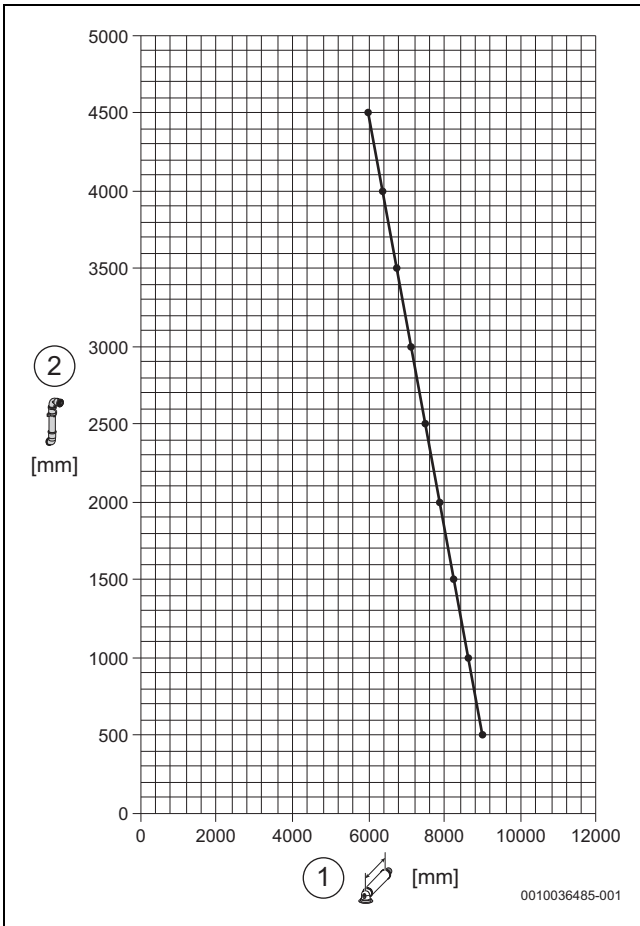

Fig. 27 Plume length to flue length graph

- [1] Flue length [mm] (maximum 12,000 mm with minimum 500 mm plume)
- [2] Plume length [mm] (maximum plume length 4,500 mm)

4.4.4 Flue terminal positions



CAUTION

Flue terminal positions

- ▶ All measurements are the minimum clearances required.
- ▶ Terminals must be positioned so to avoid combustion products entering the building.

Vertical flue terminal positions

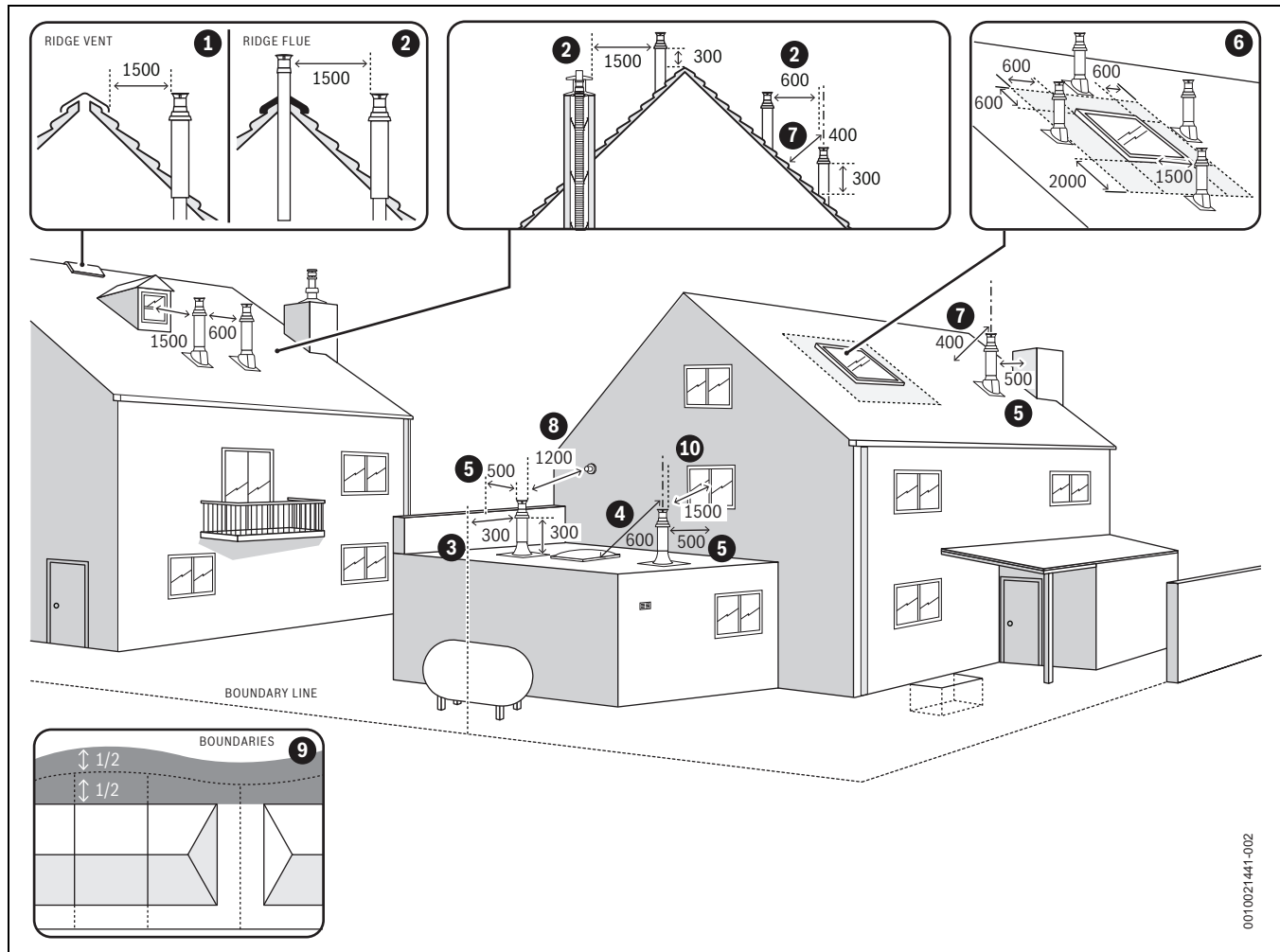

Fig. 28 Vertical flue terminal positions

Key to figure 28:

- [1] 1,500mm measured between a vertical flue terminal and an opening or vented window. 500mm measured horizontally between a vertical flue terminal and an opening or vented window providing the flue terminal is at least 300mm above the opening.
- [2] Minimum clearance to an additional flue, 600mm to a room sealed flue or 1,500mm to an open flue.
- [3] 300mm clearance from a vertical flue terminal adjacent to a boundary line, unless it will cause a nuisance. BS 5440: Part 1 recommends that care is taken when siting a terminal in relation to boundary lines.
- [4] 600mm minimum clearance measured from an opening or vented skylight to a vertical flue terminal. If the terminal is within 1,500mm of the opening or vented skylight then it must be at least 300mm above the opening.
- [5] 500mm clearance measured horizontally from a vertical flue to a vertical structure.
Not required if the terminal is 300mm above the structure.
- [6] The flue must not penetrate the roof in the shaded area.
The terminal must be at least 1,500mm from the opening or vent
- [7] 400mm measured diagonally from a pitched roof or 500mm in regions with heavy snow fall. 300mm measured vertically from the air intake to the closest intersection with the roof.
- [8] 1,200mm separation measured between a vertical flue and a horizontal flue terminal.
- [9] For the purpose of determining suitable flue terminal positions for gas appliances, the boundary can be considered to extend to the centre line of any adjacent routes or waterways e.g. paths, streets, rights of way, canals, rivers or railways.
- [10] 1,500mm measured between a vertical flue terminal and an opening or vented window. 500mm measured horizontally between a vertical flue terminal and an opening or vented window providing the flue terminal is at least 300mm above the opening.



Note:

- Where a vertical flue terminates in an area that is enclosed on 3 sides, the flue must be no more than 1,000mm below the lowest roof line. You must ensure that all clearances are maintained and that products of combustion disperse safely from the area.

Horizontal flue terminal positions

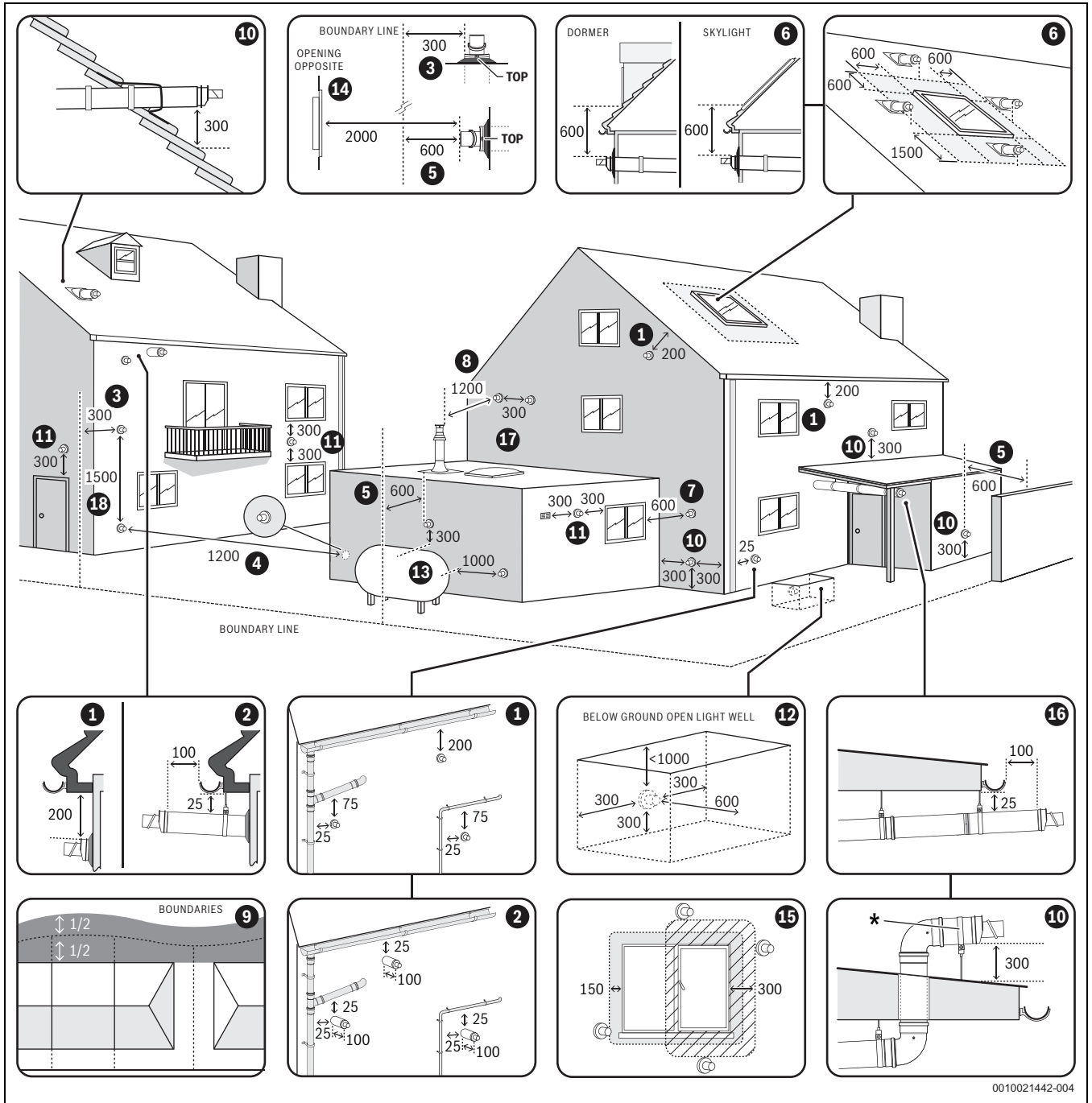

0010021442-004

Fig. 29 Horizontal flue terminal positions

Key to figure 29:

- [1] 200mm below eaves and 75mm below gutters, pipe and drains.
- [2] The dimension below eaves, gutters, pipes and drains can be reduced to 25mm, as long as the flue terminal is extended by 100mm past any overhang. The telescopic flue joint must be sealed with suitable silicone sealant if it is external to the building.
- [3] 300mm adjacent to a boundary line, unless it will cause a nuisance. BS 5440: Part 1 recommends that care is taken when siting terminal in relation to surfaces or boundary lines.
- [4] 1,200mm separation measured between terminals facing each other.
- [5] 600mm distance to a surface or boundary line facing a terminal, unless it will cause a nuisance. BS 5440: Part 1 recommends that care is taken when siting terminal in relation to surfaces or boundary lines.
- [6] The terminal must be at least 1,500mm from the opening or vent when sited below the window or 600mm when sited to either side or above.
- [7] 600mm diagonally to an opening door, air vent or opening window.
If the flue terminal is at least 300mm above the adjacent opening door, air vent or opening window, then the diagonal measurement does not apply.
- [8] 1,200mm separation measured between a vertical flue and a horizontal flue terminal.
- [9] For the purpose of determining suitable flue terminal positions for gas appliances, the boundary can be considered to extend to the centre line of any adjacent routes or waterways e.g. paths, streets, rights of way, canals, rivers or railways.
- [10] 300mm to an internal or external corner. 300mm above a surface, such as the ground/ floor level or roof surface.
* If the terminal section is less than 150mm and has two screws securing it to the elbow, the terminal section will not require a supporting bracket.
- [11] 300mm above, below and either side of an opening door, air vent or opening window.
- [12] Below ground level in an open lightwell. The flue must be at least 600mm from the opposing surface and have at least 300mm clearance either side and below. The flue terminal must be no more than 1,000mm from the top of the lightwell.
- [13] Flues should clear any LPG storage by 1,000mm horizontally and 300mm above.
- [14] Proximity of flue duct outlet to boundaries, 2,000mm distance to an opening in adjacent building facing a terminal. BS 5440: Part 1 recommends that care is taken when siting terminal in relation to boundary lines.
- [15] 300mm from an opening or vented window, 150mm to a fixed unvented window.
- [16] The dimension below eaves, balconies and car ports can be reduced to 25mm, as long as the flue terminal is extended to clear any overhang. The telescopic flue joint of the terminal must be sealed with suitable silicon sealant if it is external to the building.
- [17] 300mm Horizontally from a terminal on the same wall.
- [18] 1500mm Vertically from a terminal on the same wall.

**Note:**

- ▶ Installations in car ports are not recommended.
- ▶ The flue cannot be lower than 1,000mm from the top of a light well due to the build up of combustion products.
- ▶ Dimensions from a flue terminal to a fanned air inlet to be determined by the ventilation equipment manufacturer.
- ▶ A flue terminal guard shall be fitted whenever a terminal or air inlet is fitted less than 2,000mm above ground, above a balcony or above a flat roof to which people have access.

4.4.5 Plume re-redirect and plume management terminal positions

i

Maximum and minimum plume management lengths:

- ▶ A minimum distance of 500mm must be maintained between the plume management outlet and the flue air intake.
- ▶ The maximum plume management length is 4.5 metres for the appliances detailed on the front of this manual.
- ▶ The 45° bend is equivalent to 0.75 metres of straight plume management and the 90° bend is equivalent to 1.5 metres.

NOTICE

- ▶ All measurements are the minimum clearances required.
- ▶ Refer to “Horizontal flue terminal positions” for all concentric flue terminal positions unless the flue position is specified in figure 30 “Plume re-redirect and plume management terminal positions”.
- ▶ Terminals must be positioned so to avoid combustion products entering the building.
- ▶ Support the flue at approximately one metre intervals and at a change of direction, use suitable brackets and fittings.

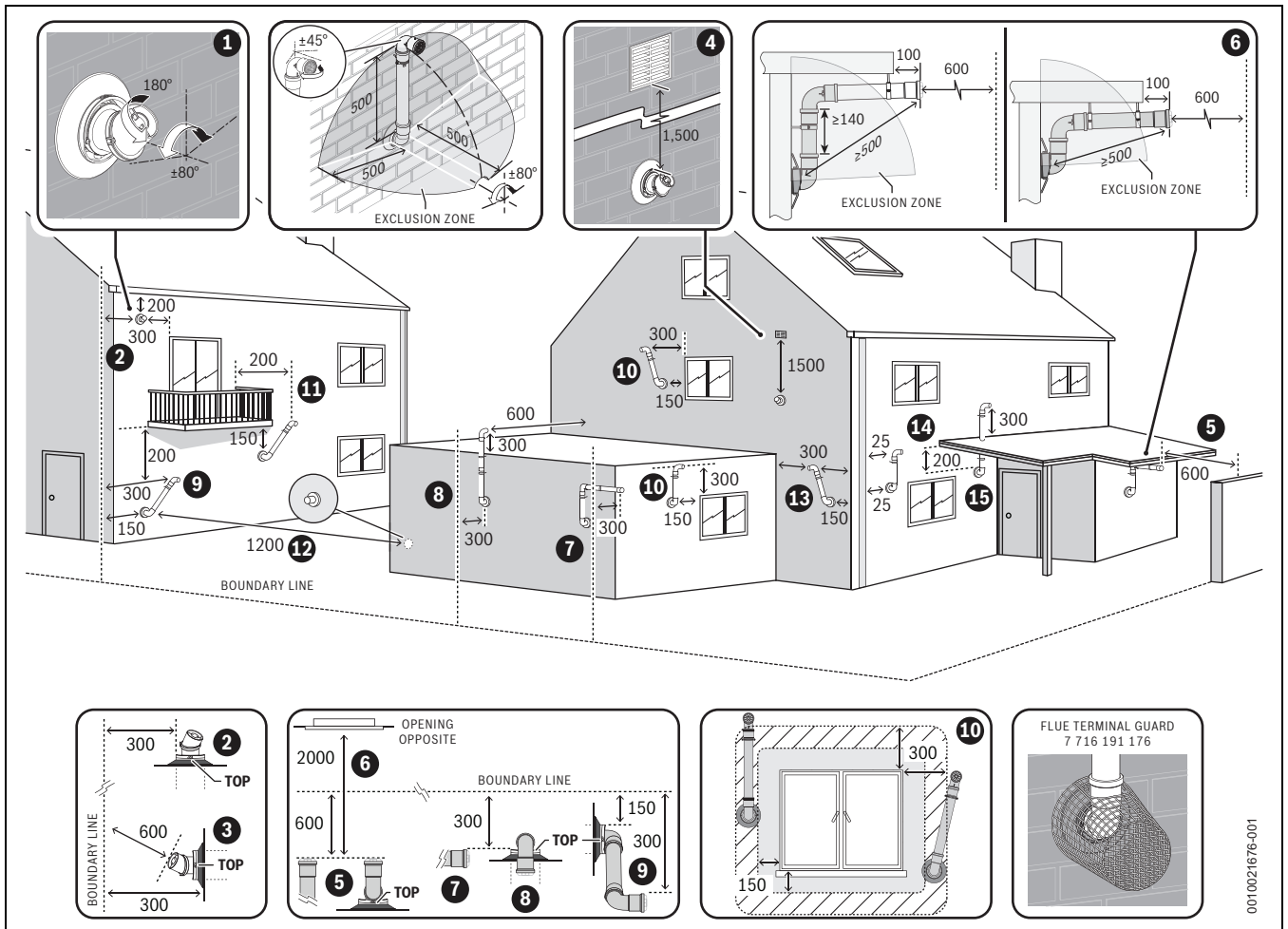

Fig. 30 Plume re-redirect and plume management terminal positions

Key to figure 30

- Plume re-direct terminal positions:

- [1] This feature allows some basic plume re-direction options on a standard telescopic horizontal flue terminal.
300mm minimum clearances to a opening e.g. window.
However the minimum clearances to an opening in the direction that the plume management is facing, must be increased to 1,500mm.
Where the flue is less than 150mm to a drainpipe and plume redirection is used the deflector should not be directed towards the drainpipe.
- [2] 300mm adjacent to a boundary line, unless it will cause a nuisance. BS 5440: Part 1 recommends that care is taken when siting terminal in relation to surfaces or boundary lines.
- [3] Where the flow of products of combustion is not at right angles to the boundary, the 600mm dimension may be measured in the direction of flow as long as the terminal is not less than 300mm from the boundary.
- [4] When redirecting the flue discharge the terminal end must be at least 1,500mm from any opening in the direction of the discharge to prevent combustion products from entering the building.

Key to figure 30

- Plume management terminal positions:

- [5] 600mm distance facing a surface or a boundary line, unless it will cause a nuisance. BS 5440:Part 1 recommends that care is taken when siting a terminal in relation to surfaces or boundary lines.
- [6] Proximity of flue duct outlet to boundaries, 2000mm distance to an opening in adjacent building facing a terminal. BS 5440: Part 1 recommends that care is taken when siting terminal in relation to boundary lines.
- [7] 300mm adjacent to a boundary line, unless it will cause a nuisance. BS 5440: Part 1 recommends that care is taken when siting terminal in relation to surfaces or boundary lines.
- [8] 300mm distance from a boundary line to the air intake as long as the exhaust terminal faces away from the boundary line. The exhaust terminal must have a minimum 300mm clearance to a surface below and there must be at least 600mm clearance when measured horizontally in a straight line from the exhaust terminal to any other surface.
- [9] Plume Management kit air intake can be reduced to 150mm providing the flue exhaust outlet is no less than 300mm adjacent to a boundary line.
- [10] Above, below and either side of an opening door, air vent or opening window.
Using a Plume Management kit the air intake measurement can be reduced to 150mm providing the flue exhaust outlet has a 300mm clearance.
- [11] Below balcony or overhang. The air intake clearance can be reduced to 150mm providing the flue exhaust outlet has a 200mm clearance.
- [12] 1,200mm between terminals facing each other¹⁾.
- [13] Internal/external corners. The air intake clearance can be reduced to 150mm providing the flue exhaust outlet has a 300mm clearance.
- [14] Clearances no less than 200mm from the lowest point of the balcony or overhang.
- [15] If a plume management kit is installed within the confines of a carport or other covered, partially enclosed extension, then the exhaust terminal must be positioned at least 1200mm away from any opening into the building which is sited within the footprint of

the carport.

If the exhaust terminal is extended at least 300mm beyond the footprint of the carport then the distance from the terminal to an opening within the carport can be reduced to 600mm.

The exhaust terminal can also be routed though the roof of the carport providing 25mm clearance is provided around the flue pipe to any flammable material and that it extends at least 300mm above the roof.

The air intake must have a minimum 150mm clearance to any opening in the building in order to ensure the integrity of the structure is maintained. If the exhaust terminates within the footprint of the carport then the carport must have at least 2 sides completely open. If the exhaust terminates at least 300mm beyond the footprint of the carport then the carport must have at least one completely open side. The exhaust terminal must be positioned to ensure that plume will not cause nuisance or damage to vehicles and that minimum clear distances in front of the terminal will not be impeded by vehicles.



Note:

- ▶ Installations in car ports are not recommended.
- ▶ The flue cannot be lower than 1,000mm from the top of a light well due to the build up of combustion products.
- ▶ Dimensions from a flue terminal to a fanned air inlet to be determined by the ventilation equipment manufacturer.
- ▶ Plume kits running horizontally must have at least a 3° fall back to the appliance for proper disposal of condensate, except or the initial horizontal run from the terminal.
The initial plume kit horizontal run will have at least a 10° fall back to the appliance, due to the terminal elbow design, for proper disposal of the condensate.

1) 600mm in case two plume management kits are used on opposing terminals. Each terminal should use a minimum length of 500mm plume management.

4.5 Condensate discharge



Full details on condensate discharge.

- ▶ Follow the latest version of **BS6798** and HHIC guidance.

For correct installation and trouble free operation of the appliance the following advice should be followed:

1. To minimise the risk of freezing, wherever possible, the condensate drain should be installed internally.
2. All condensate pipe work must 'fall' from the appliance by a minimum of 3° (52mm per metre) to ensure adequate condensate flow.
3. The pipe work route must allow air to be supplied back to the appliance for correct operation.
4. Connection to a rainwater down pipe must include an air break.

Also:

- Assessment of the risk of the condensate pipe freezing must be carried out and appropriate precautions taken where necessary. This must take into account the specific site conditions.
- The condensate pipe work connected to the condensate drain outlet on the appliance should have a minimum internal diameter (ID) of 19mm.
- Keep external pipe work as short as possible. Further precautions against freezing must be taken if external pipe runs exceed 3m.
- External pipe work should have a minimum internal diameter (ID) of 30mm.
- Minimise the number of bends and connectors.
- Remove burrs and cutting debris after the cutting pipe.
- Remove surplus solvent from the interior of the pipe.
- The condensate pipe work shall be run in standard drainpipe material, e.g. polyvinyl chloride (PVC), unplasticised poly vinyl chloride (PVC-U), acrylonitrilebutadiene.styrene (ABS), polypropylene (PP) or chlorinated poly vinyl chloride (PVC.C).

4.5.1 Condensate pipework

NOTICE

General consideration

- ▶ Where a new or replacement appliance is being installed, access to an internal "gravity discharge" point should be one of the factors considered in determining appliance location.
- ▶ Condensate pipe connection at the appliance: The condensate pipe must have a nominally outside diameter of 22mm plastic pipe.
- ▶ Ensure there are no blockages in the pipe run.
- ▶ Ensure that the discharge method for the installation can effectively handle the condensate waste from the appliance.

NOTICE

Unheated internal areas.

The condensate discharge may freeze in areas during prolonged cold temperatures.

- ▶ Internal pipe runs in unheated areas such as lofts, basements and garages should be treated as external runs and consideration should be given to using a CondenseSure siphon.
- ▶ For additional information refer to "External Connections" (Chapter 4.5.4 page 30)

4.5.2 Condensate production

When the appliance is in operation it can produce between 1 to 2 litres of condensation per hour.

This discharge is a constant drip feed during the production of condensate and does not release in frequent large volume discharges repeatedly.

4.5.3 Internal connections



Good Practice

- ▶ The following guidance indicates the good practices that must be maintained for the Installation and Maintenance of a product.

Soil stack connection

→ Figure 31

In order to minimise risk of freezing during prolonged cold spells, the following methods of installing condensate drainage pipe should be adopted.

Wherever possible, the condensate drainage pipe should be routed and terminated so that the condensate drains away from the appliance under gravity to a suitable internal foul water discharge point such as an internal soil and vent stack. A suitable permanent connection to the foul waste pipe should be used.

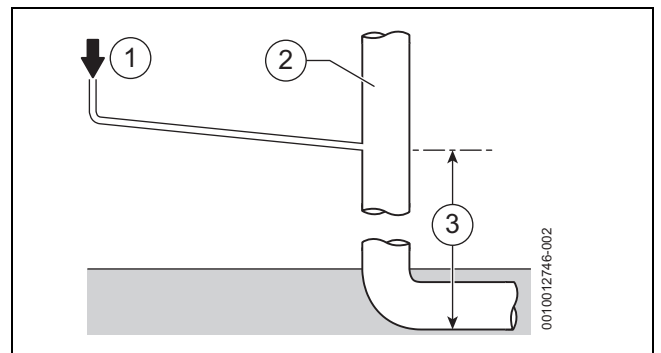

Fig. 31 Disposal to soil vent stack

- [1] Condensate discharge from appliance
- [2] Soil and vent stack
- [3] Minimum 450mm and up to 3 storeys

Waste pipe connection

→ Figure 32

Alternatively if the first option is not possible an internal kitchen, bathroom or washing machine waste pipe etc. can be used. Ensure that the condensate drain pipe is connected “down stream” of the waste trap and that the condensate drain enters into the top of the pipe using a swept tee.

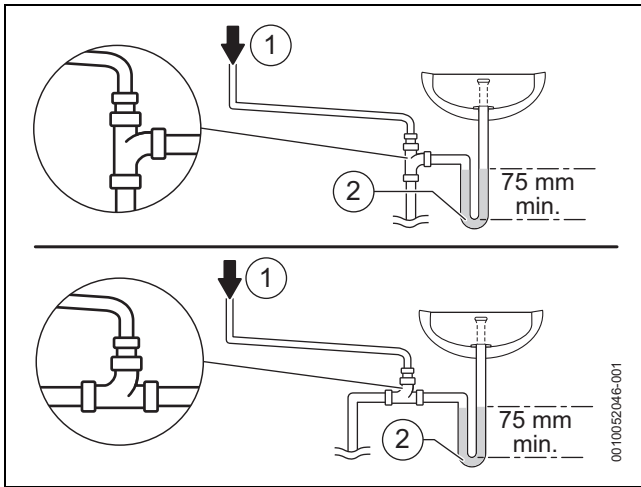

Fig. 32 Waste pipe disposal

- [1] Condensate discharge from appliance
- [2] 75 mm sink waste trap

Condensate pump

→ Figure 33

Where direct connection to “gravity discharge” pipework is not physically possible, or where very long internal runs would be required to reach a suitable discharge point, condensate should be removed using a proprietary condensate pump, of a specification recommended by the condensate pump manufacturer.

- The pump outlet should discharge to a suitable “gravity discharge” outlet.
 - The condensate then flows, by gravity, through the 22mm plastic pipe to the condensate discharge point.

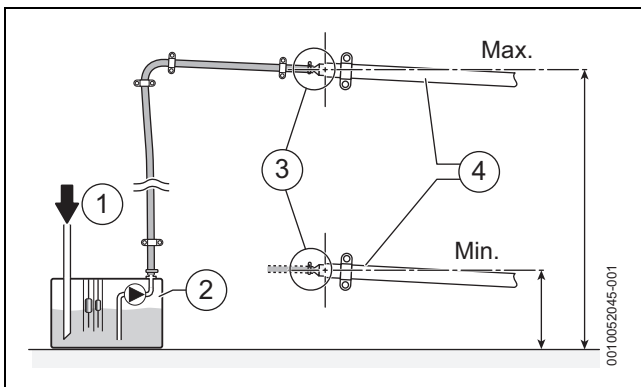

Fig. 33 Condensate pump example

- [1] Condensate discharge from appliance
- [2] Condensate pump
- [3] Pipework transition
- [4] Gravity discharge pipework



Proprietary condensate pump

- ▶ Ensure minimum and maximum pump lifting heights are followed as per condensate pump manufacturers instructions.

4.5.4 External connections

NOTICE

Septic tanks

Untreated condensate must not be allowed into septic tanks.

- ▶ Connection to systems which drain into a septic tank should be avoided due to the risk of affecting anaerobic bacteria.

NOTICE

Rainwater down pipe or external drain disposal

Untreated condensate must not be allowed to flow into streams or rivers.

- ▶ A rainwater down pipe or an external drain shall only be used for condensate disposal if the down pipe or external drain is connected to a combined foul and rainwater drainage system.
- ▶ Refer to BS 6798 for more information on condensate disposal.

NOTICE

Grey water recovery system

Contamination of recovered water

- ▶ Condensate disposal shall not be allowed into a grey water recovery system that is intended for re-use.

External disposal considerations

NOTICE

Freezing conditions

Frozen condensate will block the condensate drain pipe and stop the appliance from running

- ▶ Pipe lengths should be kept to a minimum and the routed as vertically as possible.
- ▶ All external pipework must be insulated using suitable waterproof and weather resistant insulation.
- ▶ If external pipework exceeds 3m, a CondenseSure or trace heating must be installed.
- ▶ If a CondenseSure is fitted then the guidance for a large volume condensate trap or CondenseSure should be applied.

NOTICE

Condensate waste disposal

- ▶ Care should be taken when siting a soak-away to avoid causing damage to existing services and building footings.

If no other discharge method is possible then the use of an externally run condensate drainage pipe terminating at a suitable foul water discharge point, or purpose-designed soak away, may be considered. If this method is chosen then the following measures should be adopted:

- ▶ The external run be kept as short as possible and ideally should not exceed three metres.
Additional precaution against freezing must be taken if the external pipe run does exceed three metres.
- ▶ The pipe should be run internally as far as possible before going externally and the pipe diameter should be increased to a minimum internal diameter (ID) of 30mm before it passes through the wall to the exterior.
- ▶ The hole through the wall for the condensate pipe should be sleeved and be sealed to the building fabric on the internal and external face using a suitable building material.
- ▶ The external pipe should take the shortest and least exposed route to the discharge point, and should "fall" as steeply as possible away from the appliance, with no horizontal runs in which condensate might stand.
- ▶ The use of fittings, elbows etc. should be kept to a minimum and any internal burrs on cut pipe work should be removed so that the internal pipe section is as smooth as possible.
- ▶ All external pipe drainage will be improved if the end is cut at 45° as opposed to a straight cut.
- ▶ In situations where there are likely to be extremes of temperature or exposure, the use of a proprietary trace-heating system for external pipe work, incorporating an external frost thermostat, should be considered. All other guidance above and the instructions for the trace heating system, should be closely followed.
- ▶ As well as trace heating, other methods for protecting pipe work that are run externally should be considered to prevent freezing during prolonged periods.
 - Insulation materials can be used, these should be of class "O" grade with an outer coating that is weather proof and have a UV resistant finish. A minimum of 19mm thick insulation is recommended for 32mm external pipes.
 - The use of a drain cover (such as those to prevent leaf blockage) may offer further protection from wind chill.

Additional protection for transition through a wall.

The external pipework can be insulated to help prevent freezing during prolonged cold periods.

- Where insulation is required, the entire run of external pipework [5] should be insulated with a recess in the external face allowing better insulation protection coverage [4] as it transitions to the outside of the building.
- The hole through the wall must be sealed to the building fabric on the internal [1] and external [3] face using a suitable building material, (use a 40mm sleeve [2] to pass the condensate pipework through and then seal the internal and external faces).

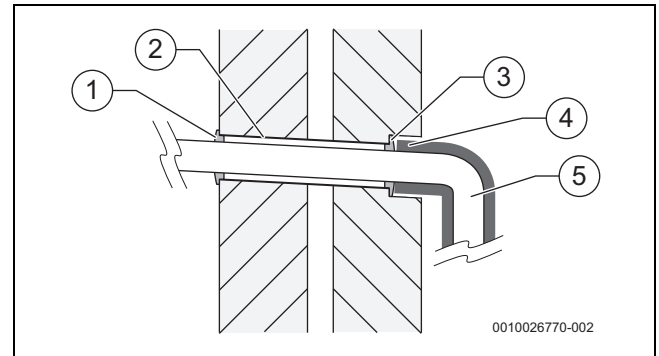

Fig. 34 Additional protection for transition through a wall

- [1] Internal face sealed (32mm pipe sealed to sleeve)
- [2] 40mm sleeve
- [3] External face sealed (32mm pipe sealed to sleeve)
- [4] Insulation recessed into the wall
- [5] Condensate discharge pipe



Good Practice

- ▶ The following guidance indicates the good practices that must be maintained for the Installation and Maintenance of a product.

Rain water down pipe with external air break

→ Figure 35

- Refer to following example to dispose of condensate to a rain water down pipe.
- An air break or rain water hopper must be utilised, between the appliance condensate outlet and the drainpipe, outside the property, to avoid flooding of the appliance should the downpipe become obstructed.

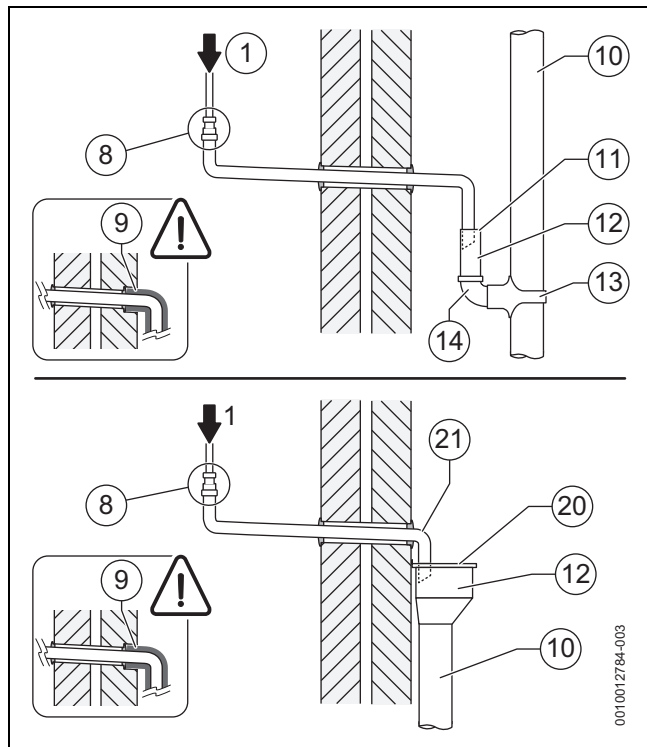

Fig. 35 Disposal into rain water down pipe

- [1] Condensate discharge from appliance
- [8] Pipework transition
- [9] Appliances with small capacity trap without CondenseSure accessory fitted. (→ page 33)
- [10] External rain water pipe to foul water
- [11] External air break
- [12] Air gap
- [13] Strap-on fitting
- [14] 43mm 90° male/female bend
- [20] Rain water hopper
- [21] Increase pipe size

Open drain or gully with external air break

→ Figure 36

Where the pipe terminates over an open drain or gully and there is a risk of ground flooding, then the additional requirement below is recommended:

- An air break should be installed in the external pipework as shown to avoid an airlock during ground flooding/adverse weather conditions which could prevent the condensate from discharging.

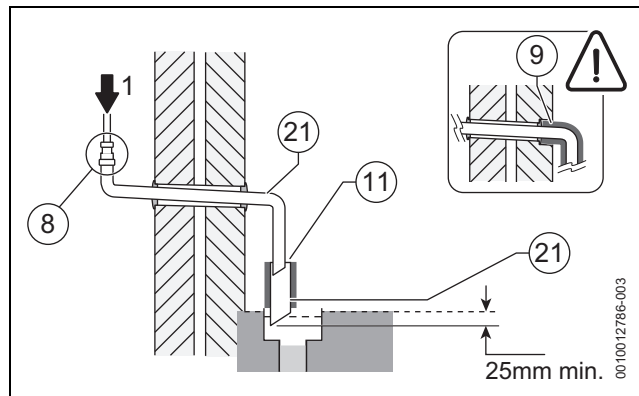

Fig. 36 Disposal to open drain or gully with air break

- [1] Condensate discharge from appliance
- [8] Pipework transition
- [9] Additional protection for transition through a wall. (→ page 31)
- [11] External air break
- [21] Increase pipe size

Condensate soak away considerations

Before deciding to use a purpose-made soak away the history of the locality and the ability of the surrounding area to disperse the condensate should be taken into account, e.g. areas prone to flooding and ground with a high clay content can result in poor drainage with an increased risk of water logging or freezing causing the condensate pipe to become obstructed by water or ice and the boiler to shut down,

Although it is possible to increase the size of the soak away and the area with limestone chippings in clay soil areas, if the clay content is high and prevents effective dispersal of the condensate then a soak away may not be a suitable means of condensate disposal and an alternative method should be used.

Condensate soak away with external air break

→ Figure 37

- Refer to following example to dispose of condensate to a soak away.
- The condensate soak away must be sited at least 500mm away from building footings.
- The condensate drainage pipe may be run above or below the ground to the soak away. The following example shows drainage pipe run above ground.
- The soak away must use a minimum of a 100mm Ø plastic tube with two rows of three 12mm holes on 25mm centres and 50mm from the bottom of the tube. The holes must face away from the house.
- The tube must be surrounded by at least 100mm of limestone chippings to a depth of 400mm.
- An air break must be installed in the external pipework as shown to avoid an airlock during ground flooding/adverse weather conditions which could prevent the condensate from discharging.

i Minimum hole size for the condensate soak away must be 400mm deep by Ø 300mm.

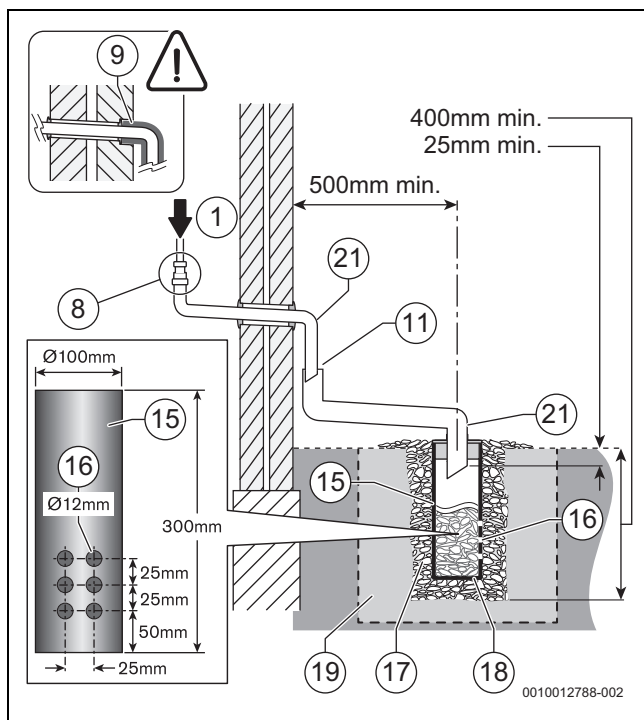

Fig. 37 Disposal to soak-away

- [1] Condensate discharge from appliance
- [8] Pipework transition
- [9] Appliances with small capacity trap without CondenseSure accessory fitted. (→ page 33)
- [11] External air break
- [15] 100mm minimum Ø plastic pipe
- [16] Drainage holes
- [17] Limestone chippings
- [18] Bottom of sealed tube
- [19] Increase size of soak away size and the area with limestone chippings if in clay soil area.
Not recommended for high clay soil areas.
- [21] Increase pipe size



Minimum Standard

- ▶ The following guidance indicates the minimum standards that must be maintained for the Installation and Maintenance of a product.

Appliances with small capacity trap without CondenseSure accessory fitted.

All external pipework must be insulated using suitable waterproof and weather resistant insulation.

External pipework exceeding three metres in length.

- ▶ One of the following must be installed:

- ▶ Trace heating,

-or-

- ▶ A condensate pump,

-or-

- ▶ A CondenseSure accessory.

Trace heating fitted:

- Check with trace heating manufactures instructions for additional requirements.

Condensate pump or CondenseSure fitted to the appliance:

- Installations with increased risk of freezing due to environmental factors:
 - Insulating the condensate pipework through the external wall [2] must be carried out.
 - The hole through the wall must be sealed to the building fabric on the internal [1] and external [3] face using a suitable building material.

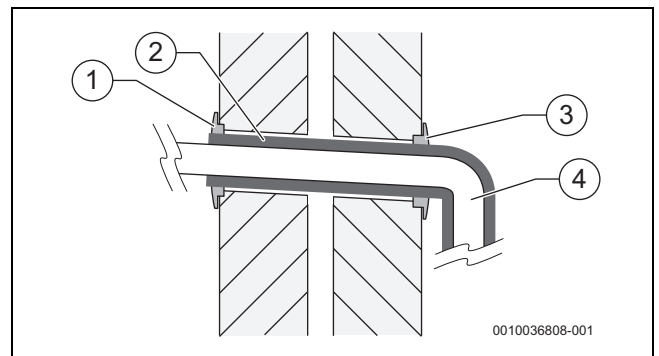

Fig. 38 Through the wall lagging example

- [1] Internal face sealed
- [2] Insulation
- [3] External face sealed
- [4] Condensate discharge pipe

4.6 Pressure relief discharge

4.6.1 Pressure relief pipework



CAUTION

Scalding risk from hot water or steam!

- ▶ The pressure relief valve (PRV) is an appliance safety device and may discharge hot water or steam when activated.
- ▶ The outlet pipe should be sited in such a way that it does not cause a hazard or an obstruction when discharging, for example above a window, entrance door or other public access way.
- ▶ The point of termination should provide a visual indicator in case the PRV discharges.

- The pressure relief discharge pipe [1 or 3] should be run in pipe which has a diameter of at least 15mm, that is made of copper or a material that will withstand PRV discharge temperatures and pressures, and which complies with BS 5254 or BS EN 1451.
- Plastic pipework must be properly supported with a maximum of 300mm between supports to prevent sagging.
- The PRV discharge pipe must run continuously downwards away from the appliance to a safe point of discharge.
- The pressure relief should discharge away from any electrical or other hazard, preferably to an external drain or soak-away.
- The pipe [1 or 3] should be finished with a partial bend, to face the external wall (as shown) to ensure safe discharge of hot water.
- In all normal circumstances a PRV discharge pipe installation as described above sufficiently meets all but the most exceptional circumstances.
 - Where the PRV discharge pipe could be susceptible to damage, vandalism, freezing etc that could cause either a blockage or restriction in the ability to discharge safely then a tundish should be considered. The tundish should be sited in a position where damage to the property or injury to occupants cannot occur from any spillage or discharge.

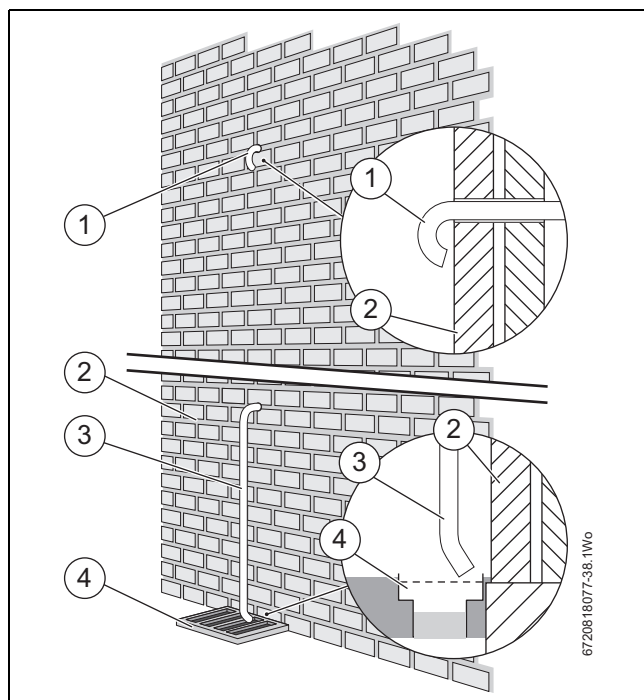

Fig. 39 Pressure relief pipework

- [1] Discharge pipe (turned back onto external wall example)
- [2] Outside wall
- [3] Discharge pipe (into drain or gully example)
- [4] External drain

4.6.2 Alternative PRV connections - Combined PRV/condensate

The PRV or a combined PRV/condensate discharge can be connected into a suitable internal waste system, the installer must ensure that all the pipework, including the waste pipe, is capable of withstanding PRV temperatures and pressures.

Connection to a waste water pipe is possible by using either:

- A shielded tundish with non-return valve used to discharge upstream of a trap (there must not be a trap directly in the PRV discharge pipe without a tundish).
- A PRV can discharge directly into a suitable waste pipe downstream of a trap. Connections must be on top of the pipe to ensure they do not block. A Hotun (or similar) can be fitted for visual indication if desired but is not necessary.

The guidance of BS 6798 sections 6.3.5 and 6.4.3.2a must be followed.



For installations where it is not possible to run the PRV discharge pipe continuously downwards away from the appliance, the remote PRV kit can be used to remove the PRV from the appliance and relocate it to a higher position.

4.7 Cleaning primary systems

NOTICE

Risk of damage to system or appliance!

Debris from the system can damage the appliance and reduce efficiency. Failure to comply with the guidelines for the use of water treatment with the appliance will invalidate the appliance guarantee and contravene the Building Regulations.

- ▶ It is a requirement of the Building Services Compliance Guide which is a second tier document to the Building Regulations to flush and inhibit the primary water system in accordance with BS 7593.
- ▶ The Building Services Compliance Guide recommends that a primary water cleanser is fitted to the system.
- ▶ Worcester Bosch recommend fitting a filter that will help remove both magnetite and non-magnetic debris.

NOTICE

Risk of damage to system or appliance!

- ▶ Salt based, artificially softened water that adjusts the pH value MUST NOT be used to fill the system.
- ▶ Alternatively there are water softening/treatment products that do not adjust or alter the pH levels of the water. With these products it may not be necessary to provide an untreated water by-pass to the primary water filling point of the heat system

NOTICE

Sealing agents

Normally the addition of sealing agents to the system water is not permitted as this can cause problems with deposits left in the heat exchanger.

- ▶ Heating systems may lose small amounts of water over time. In cases where all attempts to find a system micro leak have failed, Worcester, Bosch Group supports the use of Fernox F4 leak sealer.

Before cleaning the system:

- ▶ Ensure that the system and pipework is in good working order.
- ▶ **Where possible keep the existing appliance/circulating pump in place when flushing the system before installing the new appliance. Alternatively use an after market power flushing system or similar to remove magnetite and other debris from the central heating system.**
 - Even new central heating systems contain contaminants that need to be removed before treating the system with inhibitor/anti-freeze.
 - When an appliance is installed onto a new system then it is possible to use the appliance whilst cleaning the system. A system filter must be fitted to the return to reduce the risk of contaminants entering the appliance.
- ▶ **Follow the guidance of BS7593.**

Inhibitor

Add a suitable inhibitor or combined inhibitor/anti-freeze, if the system is exposed to freezing conditions, to the heating system in accordance with the DWTA code of practice and manufacturer's guidelines.

Products approved to the BuildCert standard are deemed as compatible with the components and equipment within the appliance and system.



The inhibitor or combined inhibitor/anti-freeze must not cause damage to the materials within the appliance (aluminium, mild steel, stainless steel, copper and brass) and any other materials/components within the system.

- ▶ The concentration level of inhibitor in the system should be checked every 12 months or sooner if system content is lost.

Water treatment products

Suitable water treatment products can be obtained from the following manufacturers:

ADEY	01242 546700 www.adey.com
FERNOX	0330 100 7750 www.fernox.com
SENTINEL	01928 704330 www.sentinelprotects.com/uk

Table 19

4.7.1 Flushing the system

Flushing the system using existing appliance/circulating pump or new appliance.



Existing appliances/circulation pumps

- ▶ An existing appliance/circulating pump should be used to flush the system before the new appliance is installed.
-



New appliances

- ▶ A new appliance must only be used to assist the cleaning of a **newly installed** system.
-

- ▶ Fill the system with cold water and check for leaks.
- ▶ Open all drain cocks and drain the system.
- ▶ Close drain cocks and add a suitable flushing agent **compatible with aluminium** at the correct strength for the system conditions in accordance with the manufacturer's instructions.
- ▶ Mark the position of the lockshield valves and open them fully.
- ▶ Fully open all TRVs.
- ▶ Circulate the flushing agent before the appliance is fired up.
- ▶ Run the appliance/system at normal operating temperature as directed by the manufacturer of the flushing agent.
- ▶ Drain and thoroughly flush the system to remove the flushing agent and debris. Do not drain the system through the PRV of new appliances.
- ▶ It may be necessary to use a power flushing machine to aid the cleansing procedure in some circumstances.
- ▶ Close the drain cocks and manual air vents.

For existing appliance/circulating pump actions.

- ▶ Add a suitable inhibitor to the system in accordance with the manufacturer's instructions.
- ▶ Fill the system to between 0.8 and 1.7 bar via a WRAS approved filling loop.
- ▶ Vent any air from the appliance and system.

For new appliance.

- ▶ Once the new appliance has been installed follow the guidance in Filling the appliance and adding inhibitor section.

5 Installation

NOTICE

Risk of damage to appliance or accessories.

- ▶ All the previous pre-installation sections must be read and requirements met before starting the appliance or flue installations.



CAUTION

Risk of injury through incorrect lifting and carrying!

- ▶ Only lift a manageable weight, or ask for help.
- ▶ Bend the knees and keep the back straight with feet apart, when lifting or putting down heavy objects.
- ▶ DO NOT lift and twist at the same time.
- ▶ Lift and carry object close to the body.



Appliance on site

- ▶ Check contents of delivery are undamaged.
- ▶ Remove the appliance from its packaging and check the contents against the scope of delivery.
- ▶ Once the appliance is unpacked the installation can commence.

Important handling instructions

- It is advised that two people are used to carry the carton from the vehicle to the point of delivery.
- Once the carton is in the property, the outer carton is removed first. Care should be taken when releasing the straps. If a sharp implement is used make sure the outer carton is not pierced and that the implement is used in such a way so that it may not cause personal injury.
- All sharp objects must be covered or the blade retracted after use and put away in a safe place. Care should be taken when lifting the appliance from the base and the proper technique for safe lifting of any heavy object should be strictly observed.



The appliance packaging and base tray are designed so that the appliance can be tilted backwards onto the outer carton. The carton then becomes a protective mat.

Now remove the front casing and set safely aside. This is to protect the casing from damage during installation.

Removing the front casing



The front casing is secured with two screws which are critical to maintain the case seal and to prevent unauthorised removal (electrical safety).

- ▶ Always secure the casing with these screws.
- ▶ Loosen the two screws [1] and pull the bottom of the casing forward.
- ▶ Lift off the casing.

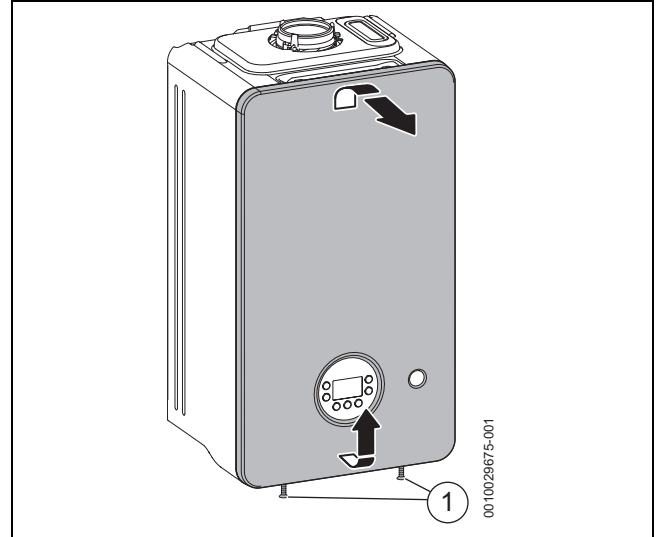

Fig. 40 Removing the front casing

Additional requirements for roof space installations

- The unpacked appliance can now be moved into the loft space
- Two sets of steps should be used.
- Two people should share the lifting of the appliance up to the loft hatch, tilt and slid on its back into the loft space.
- Ensure that the roof space has permanent fixed lighting, a permanent fixed retractable ladder and a fixed floor area, from the hatch to the appliance installation point. This will allow access for installation, normal use and servicing.



Before installing the appliance, ensure that the system has been cleaned.

5.1 Position the appliance

⚠ Risk of explosion from escaping gas!

Escaping gas can cause an explosion.

- ▶ Ensure the mains gas supply is isolated before starting any work and follow all relevant safety precautions.

NOTICE

Incorrect mounting can cause material damage.

If the appliance is mounted incorrectly, it may fall off the wall.

- ▶ Ensure the appliance is mounted onto a flat, fixed rigid surface capable of supporting the appliance weight.
- ▶ Only use screws and rawl plugs that are suitable for the wall type and weight of the appliance.
- ▶ Ensure all aspects of the installation are considered when positioning the appliance, flue run and discharge, condensate disposal, PRV discharge etc.



WARNING

Damage to property!

Damage caused by drilling into pipes, electrical cables, damp proof course or other hazards.

- ▶ Before drilling ensure that there are no obstructions or other hazards.

NOTICE

Damage to appliance!

Residue, metal shavings, and contaminants in the system pipe work can damage the appliance.

- ▶ Flush the system pipe work thoroughly to remove all residue.
- ▶ Follow the instructions with respect to cleaning primary systems.

Running pipes to the appliance.

- The area around a rear flue outlet must be avoided.

5.1.1 Mounting bracket fixing



Wall mounting template

- ▶ The wall mounting template has been sized to allow for the minimum clearances around the appliance, (→ section 4.3.3 "Appliance clearances").

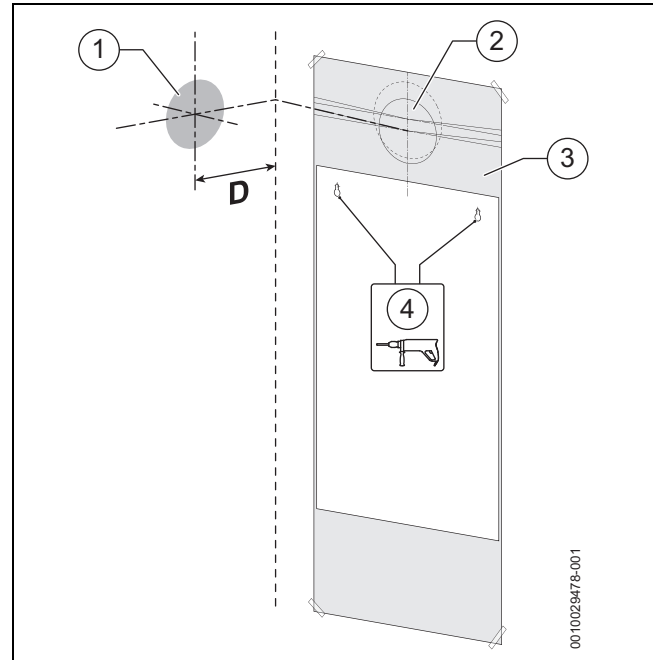

Fig. 41 Wall mounting template

- 1 Side exit flue example
- 2 Rear exit flue example
- 3 Wall mounting template
- 4 Primary fixing points
- D 125mm

The appliance wall mounting template shows the relative positions of the flue and the top fixings of the wall mounting bracket.

- ▶ Fix the wall mounting template [3] to the wall in the desired position.
- ▶ Drill the holes [4] through the template for the primary fixing points as indicated on the template.
 - Additional fixing points for the appliance will be indicated on the wall mounting template.

Flue outlet position.

The appliance wall mounting template has the flue centre lines for the following flue systems:

- 60/100mm
- 80/125mm



Flue turret adaptor

- ▶ The flue turret adaptor has an in-built 3° angle giving the flue assembly the rise from the appliance to ensure the condensate flows back to the appliance.

Rear flue outlet [2].

- ▶ Mark centre line of flue to be used; the external diameter of the hole can also be marked if required.
- ▶ If extensions are to be added then the complete flue must rise at an angle of 3° from the appliance.

Side flue outlet [1].

- ▶ Mark from the centre line of the wall mounting template to the wall which the flue will pass through.
- ▶ Allow for a rise of 52mm per metre length of flue, to give a 3° angle.

Example hole size.

- If a 60/100mm diameter flue is to be used, a 125mm diameter hole is required.
- If using the weather sealing collar by pushing it through from inside the property, then a 150mm diameter hole is required to accommodate this.

Flue outlet position marked and ready to drill hole.

- ▶ Drill hole using a core drill or similar.
- ▶ Clear any debris from the site.

Appliance fixings and flue outlet drilled and ready.

- ▶ Remove the wall mounting template.

5.2 Appliance connections

WARNING

Appliance - gas connection

- ▶ **Ensure the mains gas supply is isolated before starting any work and follow all relevant safety precautions.**

NOTICE

Appliance - hydraulic connections

- ▶ Ensure all water pipework, to be connected, are isolated/drained and follow all relevant safety precautions.
- ▶ Be careful of plastic components when using a naked flame on pipework.



Surplus water may be present inside the appliance due to factory testing.



External condensate pipework or internal pipe runs in unheated areas such as lofts, basements and garages exposed to prolonged cold temperatures should be protected (→ chapter 4.5).

Installing the Valve Set



Connection set fitting

- ▶ For ease of installation the connection sets can be connected before the appliance is mounted on the wall bracket.

Refer to figure 42.

- ▶ Ensure the sealing washers are fitted in the connection sets before installing the connection sets.

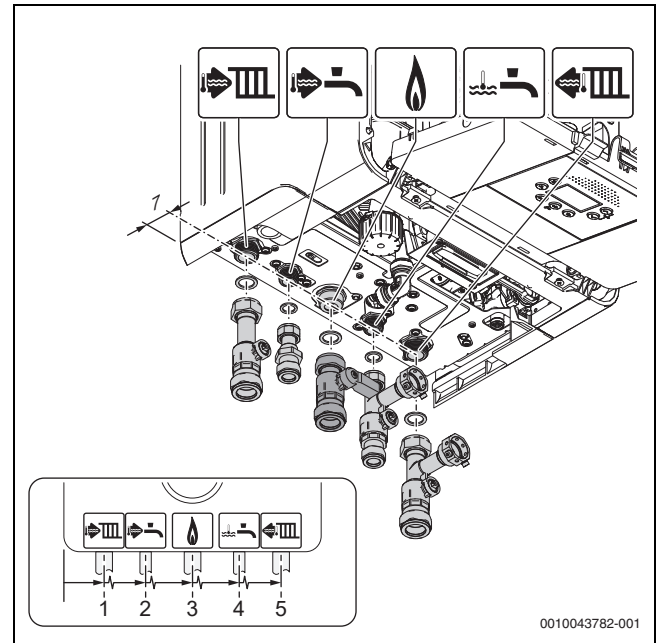

Fig. 42 Fitting the connection sets (for orientation reference)

Description	#	From left case edge	From wall
CH flow	1	70 mm	35mm
DHW outlet	2	135 mm	35mm
Gas	3	200 mm	35mm
DCW Inlet	4	265 mm	35mm
CH return	5	330 mm	35mm

Table 20

5.3 Hanging the appliance

NOTICE

Transport protection covers

- ▶ Remove any internal transport packaging and protection covers from the appliance where applicable.

NOTICE

Risk of damage to casing!

The front cover may be damaged whilst mounting the appliance on the wall.

- ▶ Remove front cover prior to hanging.

Connect PRV discharge pipe



It is recommended to fit the PRV pipework after isolation valves are fitted; to provide more tool access for compression fittings.

- ▶ It is recommended to use the PRV elbow connector [2] supplied. This provides easy installation, guards against potential harmful heat transfer if soldering and allows the boiler to be removed from the wall, if needed, with PRV pipework in place.

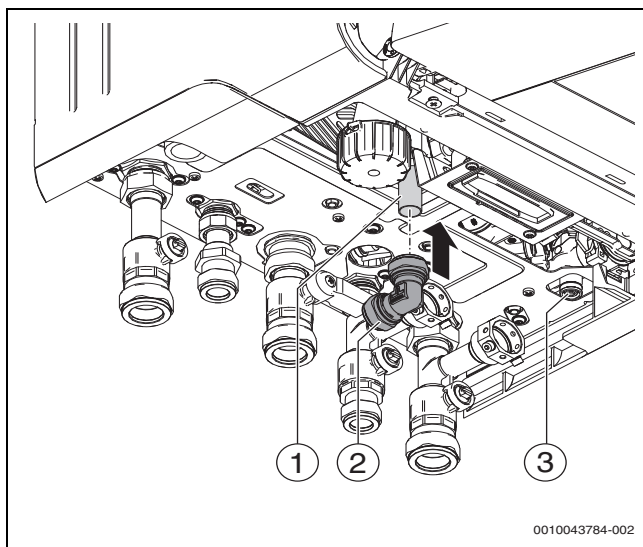

Fig. 43 Connecting to the PRV tail connection

- [1] PRV tail connection
- [2] PRV elbow connector
- [3] Drain valve



To allow for a neat installation and to avoid future access to the drain valve, please consider not to close access to the drain valve by making of the routing PRV pipe tail.

Installing pipework



Contaminated heating water can damage the appliance!

Residue in the pipework can damage the appliance.

- ▶ Flush the pipework before installing the appliance.
- ▶ Determine internal diameter for the gas supply.
- ▶ All pipe connections in the heating system must be able to withstand a pressure of 3 bar, and 10 bar in the DHW circuit.
- ▶ Install isolation valves.
- ▶ To fill and drain the heating system, install a drain valve at the lowest point of the system.
- ▶ Install the Pressure Relief Valve discharge pipe to the latest advice in BS6798.
- ▶ Always route discharge pipes with a continuous fall.

Appliance connections

NOTICE

Commissioning without water damages the appliance!

- ▶ Only operate the appliance when filled with water.

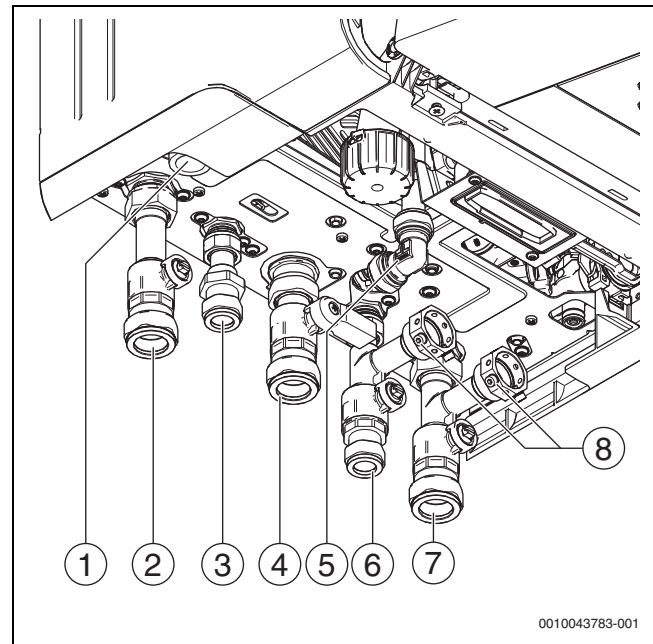

Fig. 44 Connections on the gas and water side

- [1] Condensate hose connection
- [2] CH flow valve
- [3] DHW outlet connection
- [4] Gas isolator
- [5] PRV 90 degree compression (supplied)
- [6] Cold Mains inlet valve
- [7] CH return valve
- [8] Connections for keyless filling link

- ▶ Connect the gas supply, cold mains inlet, DHW outlet and central heating flow and return.

Connect condensate discharge pipe

- ▶ Connect the condensate discharge pipe to the appliance condensate hose outlet connection.

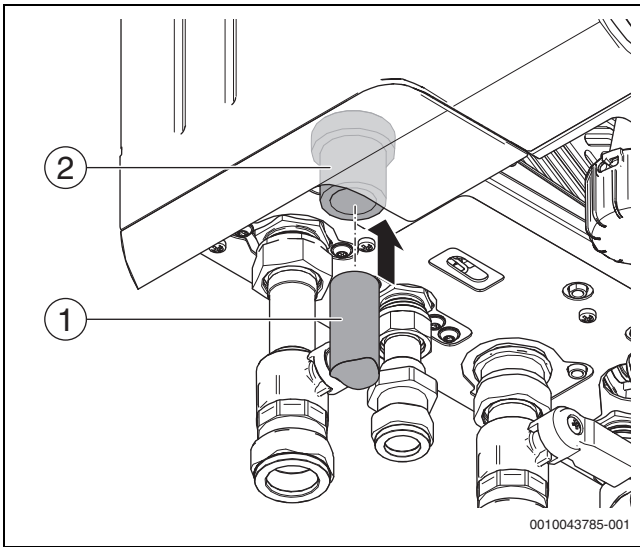

Fig. 45 Connecting to the condensate outlet connection

- [1] Condensate discharge pipe
- [2] Condensate hose outlet connection

Fitting the hose to the condensate trap

- ▶ Take the cap off the drain on the condensate trap.
- ▶ Fit the condensate hose on the condensate trap.

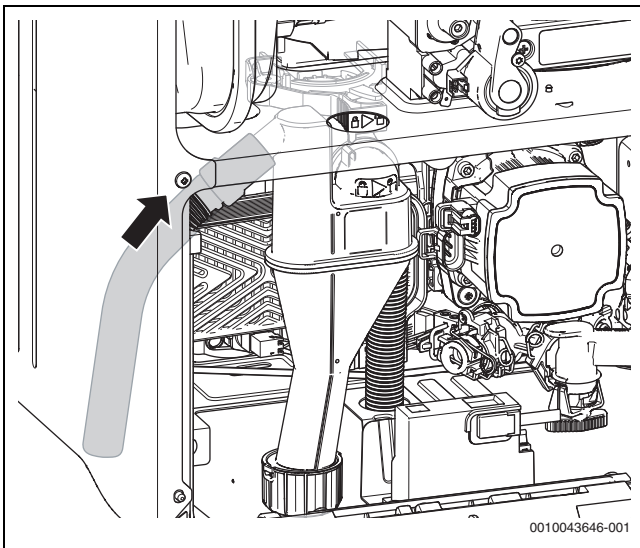

Fig. 46 Fitting the hose to the condensate trap

- ▶ Only route the condensate hose with a slope and connect it to the drain line.
- ▶ Check tightness of connection at condensate trap.

Filling the siphon

- ▶ Pour 200 to 250 millilitres of clean water through the inner flue opening to fill the siphon before running the appliance.

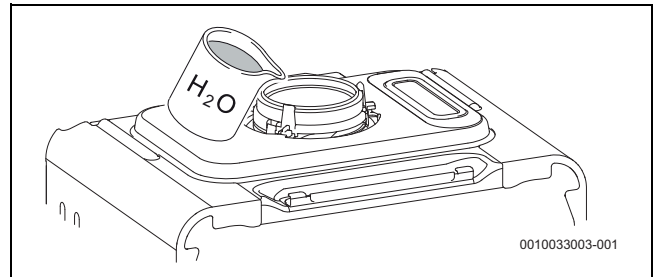

Fig. 47 Filling the siphon

5.4 Flue turret/adaptor installation

NOTICE

Flue installation

- ▶ Refer to the Flue Kit Installation instructions provided with your flue kit to correctly install the flue with this appliance.
- ▶ Do not exceed the maximum straight length for a horizontal or vertical flue or a 60mm plume management system (if used) as stated in the relevant Installation and Maintenance Instructions manual or addendum.



Telescopic flue

- ▶ Cutting the flue to an exact measurement is not required as the telescopic flue terminal can allow for some adjustment.



Apply silicone lubricant to sealing surfaces, to ease assembly of flue components. Refer to the manual supplied with the flue kit for complete installation instructions.

- ▶ For plume management effective lengths and the effective flue lengths, → chapter 4.4.

Additional notes and reminders:

- Ensure that all cut lengths are square and free from burrs.
- Ensure that the flue and seals are not damaged.
- The flue is sealed when assembled correctly, the components are pushed fully home and secured.
- The flue rises from the appliance at an angle of 3° or 52mm per metre length.
- Support the flue at each flue extension joint and at each change of direction, use suitable brackets and fittings:
 - Flue bracket 100mm part number: 7 716 191 177.
 - Flue brackets 100mm x 6 part number: 7 716 191 178.
 - Flue bracket 125mm part number: 7 716 191 179.

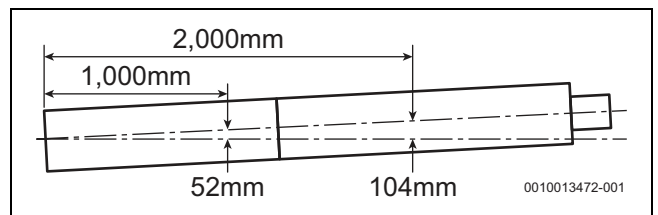

Fig. 48 Slope for condensate disposal

Refer to figure 49.

- ▶ Remove the three inner flue tube retaining screws [1].
 - The inner tube will be held in place in the appliance.
- ▶ Check the appliance flue seal [2] is correctly seated and apply silicone grease.

Flue turret [A] fitting

- ▶ Align the flue turret [A] to the appliance flue outlet with flat facing [3] to the rear of the appliance.
 - This should be pushed straight down, on to the appliance.
- ▶ The three inner flue tube retaining screws [1] are re-used to secure the flue turret [A].

Vertical adaptor [B] fitting

- ▶ Align the vertical adaptor [B] to the appliance flue outlet with flat facing [3] to the rear of the appliance.
 - This should be pushed straight down, on to the appliance.
- ▶ The three replacement retaining screws [4] supplied with the adaptor kit are used to secure the vertical adaptor [B].

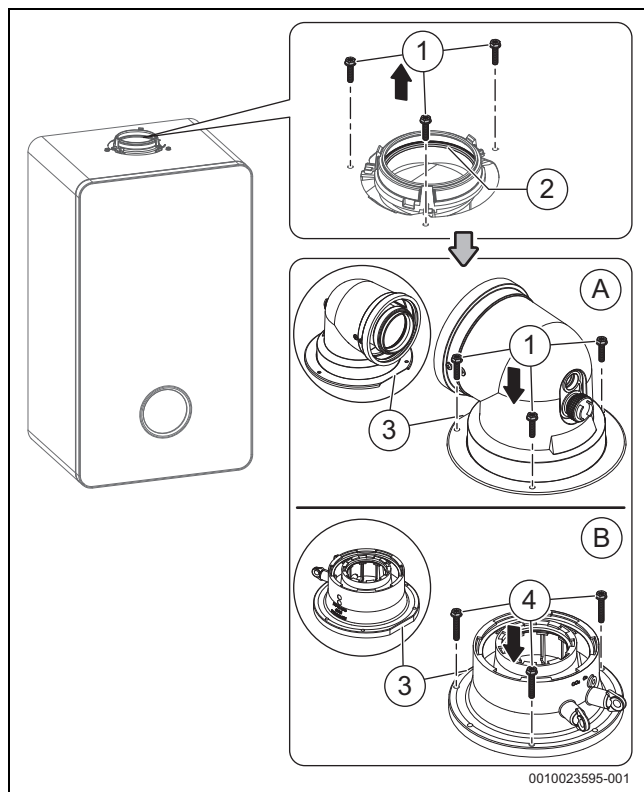

Fig. 49 Flue turret/adaptor connection

5.5 Electrical connection

DANGER

Risk of electric shock!

- ▶ Isolate electrical components from the power supply (230 V AC) (fuse, circuit breaker) and secure against unintentional re-connection before carrying out any work. Information on safe isolation can be found in the Health and Safety Executive guidance HSG85.
- ▶ Check for zero potential before proceeding with work, using test equipment approved to GS38 to confirm that the electricity supply is disconnected.

i

Electrical considerations:

- ▶ All electrical work must be carried out by a competent and authorised person.
- ▶ All work must comply with the current national and regional regulations, technical regulations and guidelines for electrical installations.
- ▶ The isolator shall be situated next to the appliance for new systems and, where practicable, replacement appliances.
- ▶ The mains electrical supply to the appliance must be through a fused double pole isolator.
- ▶ The isolator must have contact separation of 3mm minimum between poles. Any system connected to the appliance must not have a separate electrical supply.
- ▶ Any additional components that are connected to the appliance that require 230 Volts must be connected to the same supply as the appliance.
- ▶ The correct type of RCD must be employed where additional protection is required that is suitable for a low energy DC modulating pump according to the current technical wiring regulations.
- ▶ External fuse 3 Amps.
- ▶ When stripping the wires, ensure copper strands do not fall into the control box.

NOTICE

Risk of damage from hot appliance components.

Hot appliance components can damage electrical cables.

- ▶ Ensure all electrical cables are in the correct cable guides and away from hot appliance components.

i

Cable routing:

- ▶ Route cables over the valve bracket avoiding any hot components.
- ▶ Run power cables separately from signal cables. Interference from power cables can induce spurious faults on signal cables, ensure that there is at least 100mm separation between power and signal cables.
- ▶ Ensure the cables are of sufficient length to allow the control box to be moved to the service position.

If the power cable is of insufficient length, accessing the connection terminal (→ Fig. 54)

- ▶ Replace with the following cable types:
 - Cable: PVC insulated 0.75 mm² (24 x 0.2mm) temperature rated to 90 °C.
 - Wiring must comply with the latest edition of BS 7671 (IET wiring regulations).
- ▶ Connect the cable so that the protective conductor is longer than the other wires.

5.5.1 Component access

- ▶ Release catch and hinge open the control panel into the service position.

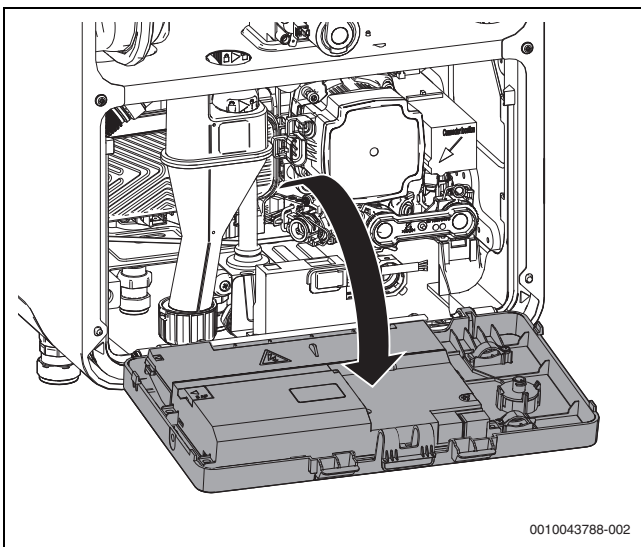

0010043788-002

Fig. 50 Moving control panel into service position

Mains cable routing

- ▶ Mains supply cable routing must be routed through the hole in the bottom plate → Figure 51.

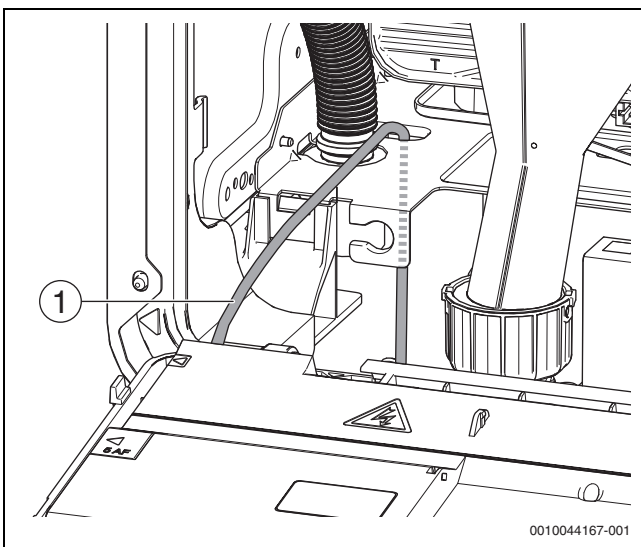

0010044167-001

Fig. 51 Mains supply cable routing

5.5.2 Installer connections

Connect external accessories

Low Voltage (signal cable) accessories connections.

- ▶ Release the latches using a thin bladed screwdriver. Arrows on the electrical cover indicate the position where the screw driver must be inserted to release the catches.
- ▶ Open the rear cover.

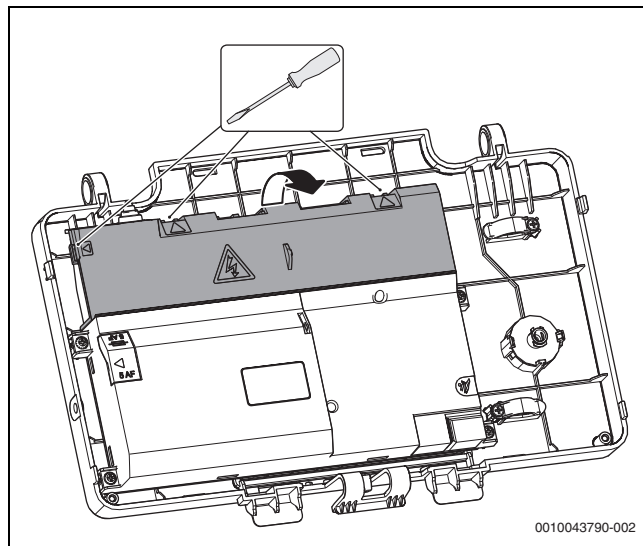

0010043790-002

Fig. 52 Open the cover

- ▶ For splash protection (IP): Cut the strain relief according to the diameter of the cable.



Care should be taken not to damage cables when cutting strain relief.

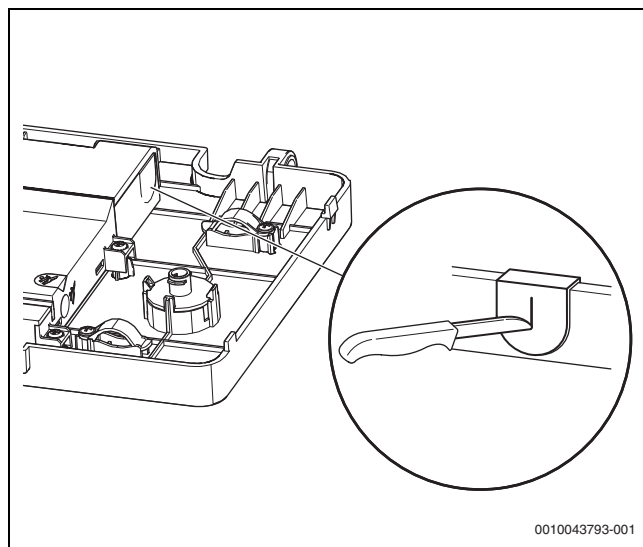

0010043793-001

Fig. 53 Cable feed

- ▶ Guide the cable through the strain relief.
- ▶ Connect the cable to the terminal block for external accessories.
- ▶ Secure the cable to the strain relief.

Replaceable mains cable (power cable) and 230v external controls connections.

- ▶ Release the catches [1] and remove cover.

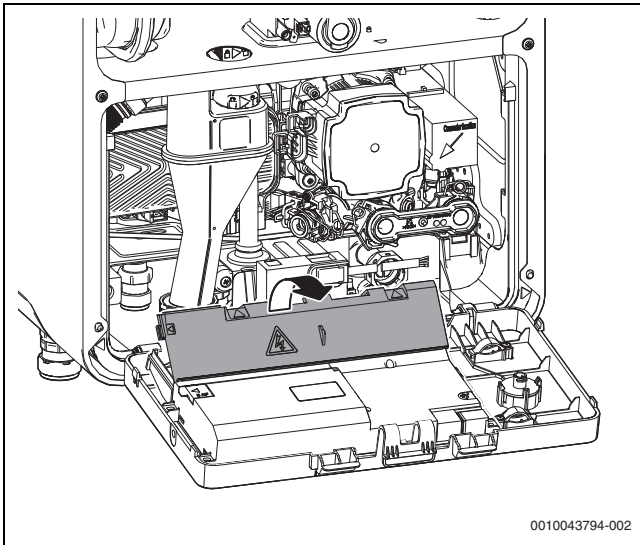

Fig. 54 Open the rear cover

- ▶ Remove the cable clamp.
- ▶ For splash protection (IP): Cut the strain relief according to the diameter of the cable [1].
- ▶ Unscrew the cable retaining screw [2].
- ▶ Guide the cable through the strain relief.
- ▶ Tighten the cable retaining screw [2] to secure the cable.
- ▶ Replace the cable clamp.

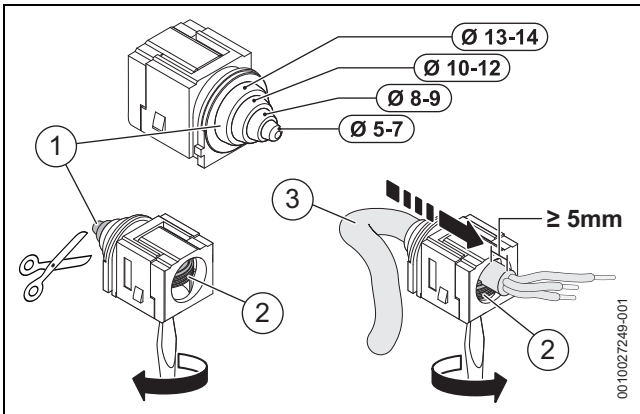

Fig. 55 Cable feed

The mains cable is pre-fitted, however, it can be replaced or upgraded by following these steps:

- ▶ Connect the power cable to the mains connector and earth bracket.

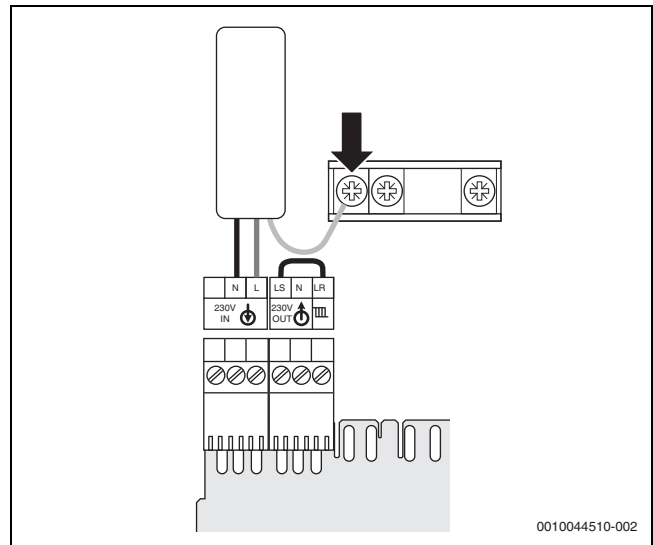

Fig. 56 Connect the power cable

- ▶ Connect the 230V external controls to the external connector and earth bracket.

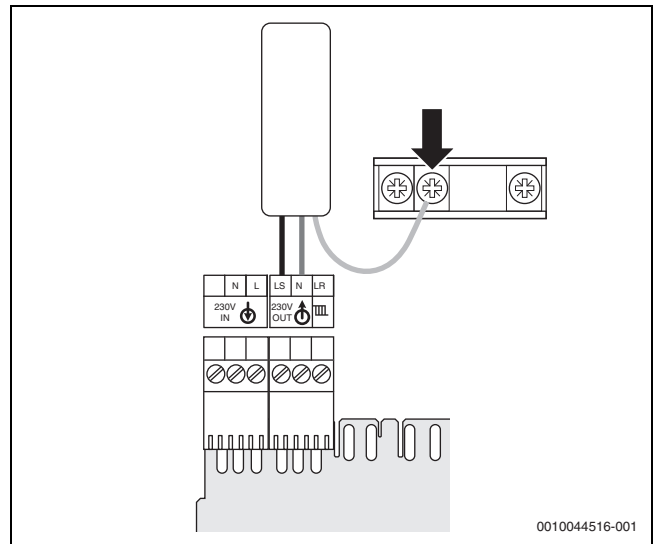

Fig. 57 Connect the power cable

- ▶ Remove the factory-fitted jumper between LS and LR.
- ▶ Remove the edge connector prior to fitting the wire. This is to remove the risk of copper strands entering the PCB and causing failures.

External accessories terminal strip

Control unit

Symbol	Function
	Not used. Only used for the domestic hot water pre-heat accessory.
	Outdoor temperature sensor (accessory)
	Communication BUS connection for hard-wired Worcester/Bosch EMS controls. Low voltage power supply for hard-wired Worcester mechanical controls.
	230V external controls connection. 230V feed output and switch live/demand input for external controls. <ul style="list-style-type: none"> External control switch live/demand (Live Return) to the appliance [LR] <ul style="list-style-type: none"> Remove link between LR and LS when connecting external 230V controls. Live output [LS] to external controls. Neutral output [NS] to external controls. Earth to be connected on earth bar within the 230V external controls interface unit.

Table 21 Terminal strip for external accessories

5.5.3 Cable preparations



The appliance is factory-fitted with a 230V mains cable. It can be replaced if a longer cable is needed or, if 230V external controls are fitted, a multi-core cable.

NOTICE

Damage to control unit!

Small pieces of wire can cause shorts and damage to electronics.

- ▶ When stripping wires always ensure copper strands do not fall into the control box.

230V mains cable (power cables), example → figure 58

- ▶ Ensure the conductors (C) can reach the appropriate terminal connection and that the protective (earth) conductor is longer than the other wires.
 - Power cables connected to the appliance may have different conductor lengths depending on the termination point.

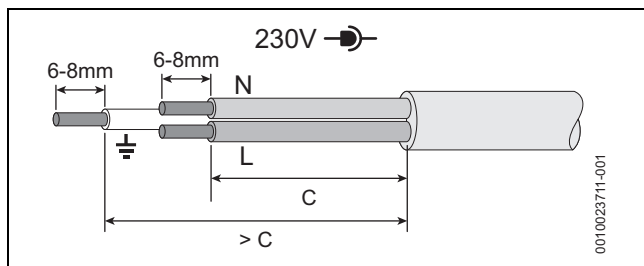

Fig. 58 Mains voltage (power cables) preparation

Low voltage (signal cables), example → figure 59

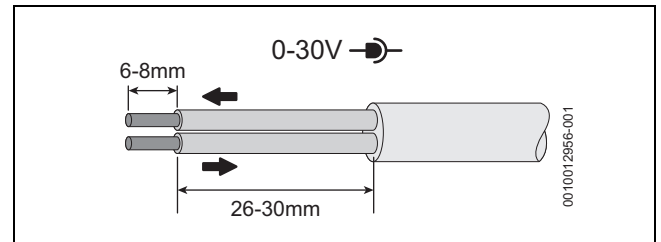

Fig. 59 Low voltage (signal cables) preparation

5.5.4 External controls - Domestic installations

Appliance external control connections example



External frost protection:

- ▶ Proprietary external frost protection will only be able to be used if external 230V controls are fitted (wired in parallel to the external 230V controls).
Worcester weather-compensating controls have built-in external frost protection functionality (→ Worcester controller Instructions manual).
- ▶ The electrical power supply to the external equipment [2] is supplied from LS (Live), NS (Neutral) terminals and PE - \perp (earth) from the earth bar.
- ▶ The Switch Live from the external equipment [3]:
 - Heating (\perp)/ zone controls connects to LR (Live Return) terminal, remove the pre-wired link.
- ▶ External frost thermostat connections [4]:
 - The Live supply is terminal LS.
 - The Switch Live is terminal LR.

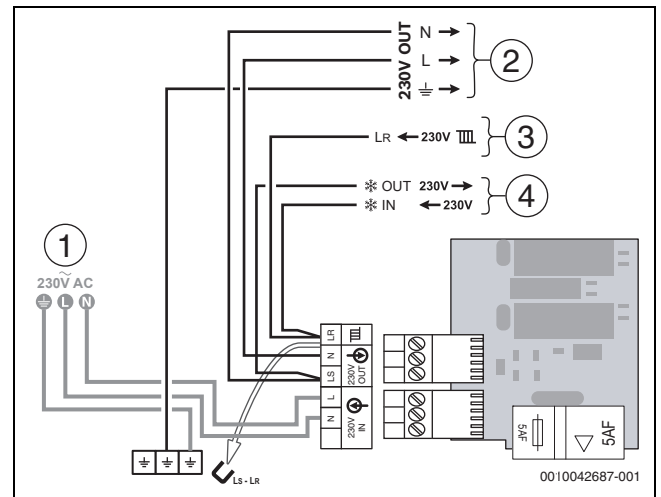

Fig. 60 External controls connections example

- [1] 230V mains supply to the appliance.
- [2] 230V supply from the appliance to the external controls.
- [3] Heating (\perp)/ zone Switch Live (Demand) from the external controls.
- [4] External frost protection Live supply and Switch Live (Demand).

6 Commissioning

6.1 Pre-Commissioning checks



DANGER

Risk of electric shock!

- ▶ Isolate electrical components from the power supply (230 V AC) (fuse, circuit breaker) and secure against unintentional re-connection before carrying out any work. Information on safe isolation can be found in the Health and Safety Executive guidance HSG85.
- ▶ Check for zero potential before proceeding with work, using test equipment approved to GS38 to confirm that the electricity supply is disconnected.

Checks before commissioning:

- ▶ Check that the service and water pipes are connected correctly.
- ▶ Inspect the entire gas installation, including the meter and conduct a tightness test in accordance to the latest gas safety technical regulations and guidelines (e.g. UK standards advice found in BS 6891).
- ▶ Check the gas type specified on the identification plate matches that of the gas supply and that the gas supply is properly purged.
- ▶ Check that the appliance is filled with water and under pressure (0.8 to 1.7 bar) and that there are no leaks.
- ▶ Check that the electrical connections of the appliance are correct:
 - Mains electrical supply - 230V, 50Hz
 - Compliant earth connection.
 - Correct polarities.
 - External equipment and controls are wired in correctly.
- ▶ Check that the flue is correctly fitted, airtight, free from any obstruction and the connections are secure.
- ▶ Check that the condensate pipework is connected properly and that there are no leaks.

NOTICE

If the appliance is not to be commissioned immediately then, after successfully completing all of the checks and any rectification work:

- ▶ Isolate the electricity supply.
- ▶ Isolate the gas supply.
- ▶ Close the water shut-off valves to the appliance.
- ▶ Label appropriately.

6.2 Water treatment

Primary system flushing (Central Heating)

Ensure that the system has been cleaned:

- Following the guidance of BS 7593:
 - Code of Practice for treatment of water in hot water central heating systems.
- Overview available in Pre-installation, Cleaning primary systems section.

Inhibitor (Central Heating):

Add a suitable inhibitor that is compatible with aluminium (or combined inhibitor/anti-freeze, if the system is exposed to freezing conditions), to the heating system in accordance with the DWTA code of practice and manufacturer's guidelines.



The pH value of the system water must be between 6.5 and 8 or the appliance warranty will be invalidated.



The inhibitor or combined inhibitor/anti-freeze must not cause damage to the materials within the appliance (aluminium, mild steel, stainless steel, copper and brass) and any other materials/components within the system.

- ▶ Record the date when the inhibitor was added to the system on the guarantee card.
- ▶ The concentration level of inhibitor in the system should be checked every 12 months or sooner if system content is lost.

NOTICE

Sealing agents

Normally the addition of sealing agents to the system water is not permitted as this can cause problems with deposits left in the heat exchanger.

- ▶ In cases where all attempts to find a system micro leak have failed, Worcester, Bosch Group supports the use of Fernox F4 leak sealer.

6.2.1 Filling the appliance and adding Inhibitor



Before pressurising the system.

The appliance integral expansion vessel is pre-charged to 0.75 bar (equal to a static head of 7.5m (24.6ft)). A Schrader type valve is fitted to the expansion vessel to allow for pressure adjustment if required.

- ▶ If an extra expansion vessel is fitted to the central heating system, ensure that it is set to the same pressure as the appliance internal expansion vessel, refer to separate instructions supplied with the extra expansion vessel.

Filling the system - Sealed systems

NOTICE

- ▶ Salt based softened water must not be used to fill the central heating system.
- ▶ Check that the drain cocks and manual air vents are closed and all radiator valves are open.
- ▶ Add a suitable inhibitor or combined inhibitor/anti-freeze, if the system might be exposed to freezing conditions, to the heating system water in accordance with the manufacturers instructions.
- ▶ Turn on the water main and open the system valves.
- ▶ Fill the system to between 0.8 and 1.7 bar via a WRAS approved filling loop or one of the filling link accessories.
 - Refer to filling link accessory instructions for operation and use.
- ▶ The Automatic Air Vent will release any air trapped in the appliance.
- ▶ Manually vent all radiators, tighten the vent screws when completed
- ▶ Check the system for any leaks and correct if required.
- ▶ Top up the system pressure if the pressure has dropped below 0.8 bar.
- ▶ Isolate and remove the filling loop connections to the system.
 - Refer to Integrated filling link accessory instructions for any further actions required after filling the system.



Keyless filling link

- ▶ An additional 0.75bar static mains pressure is required above required system pressure to ensure the effective operation of the keyless filling link accessory.

Adjusting the operating pressure of the heating system

Display on the pressure gauge

Maximum charge pressure at maximum heating water temperature must not be exceeded (pressure relief valve opens).

Table 22

If the indicator is below 1 bar when the system is cold:

- ▶ Top up the water until the indicator is between 1 bar and 1.5 bar again.

If pressure is not being maintained:

- ▶ Check tightness of expansion vessel and heating system.

Operating pressure checking of the heating system via HMI

	Displayed when system pressure is lower than 1.1 bar.
	Displayed when system pressure is higher than 1.3 bar. ▶ Stop filling the system and press the ok key.

Table 23

6.3 Circulation pump characteristic curve

Self-modulated pump (based on burner load)

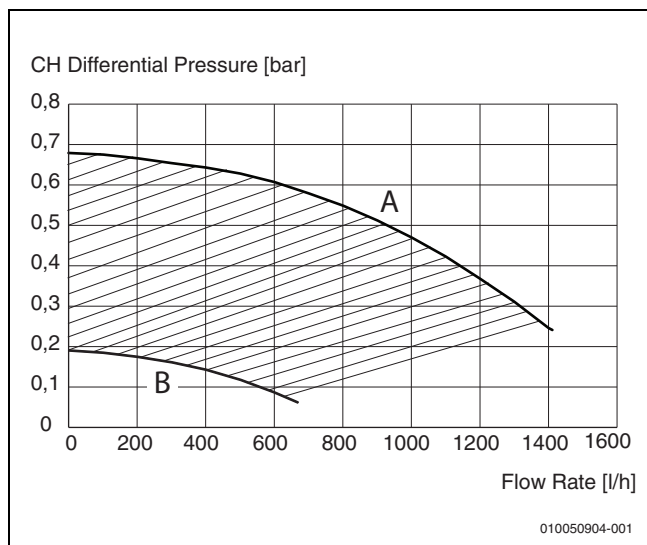

Fig. 61 Circulation pump characteristic curve

- A Pump characteristic at maximum pump speed (100%)
 B Pump characteristic at minimum pump speed (40%)

In order to save as much energy as possible and the minimize the possibility of water circulation noise, pump speed minimum and maximum values can be adjusted according to the estimated system restrictions of the installation place.

Pump speed maximum and minimum values can be selected via service menu L3 section. Minimum pump speed adjustment: L3-d3 (40% - 100%)

Maximum pump speed adjustment: L3-d4 (40% - 100%)

Factory settings are: Maximum pump speed: 100%

Minimum pump speed: 40%

6.4 Starting the appliance

NOTICE

Damage to appliance or system!

Running the appliance:

- ▶ Never run the appliance when the appliance/system is empty or partially filled.

6.4.1 Control panel overview

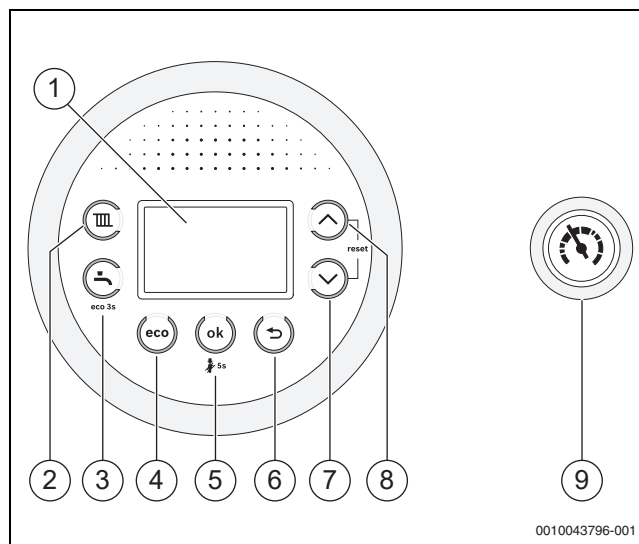

Fig. 62

- [1] Display
- [2] : Heating mode on/off, set the maximum flow temperature
- [3] : Hot water mode, adjusting the hot water temperature
- [4] **eco**: Toggle economy mode (pre-heat off)
- [5] **ok**: Save settings, Chimney sweeper key: press 5 seconds for chimney sweep mode
- [6] : Return/back
- [7] : To navigate through menus and decrease settings
- [8] : To navigate through menus and increase settings
- [9] Pressure gauge

6.4.2 Screen display

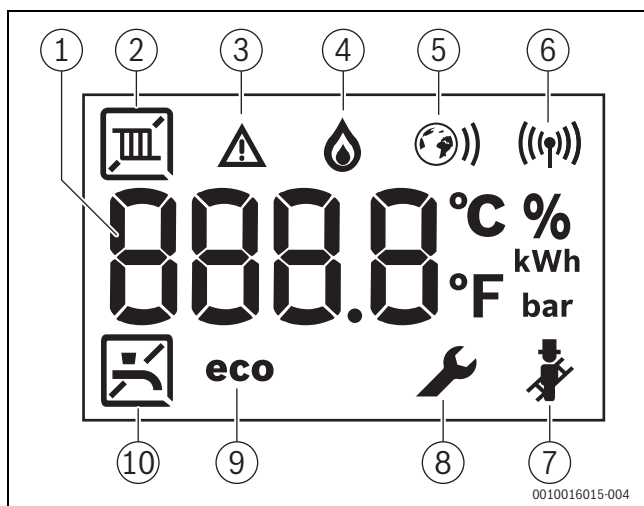

Fig. 63 Screen display

Key	Explanation
[1]	Digital display <ul style="list-style-type: none"> Displays a temperature or appliance status/diagnostic code.
[2]	Central heating (CH) <ul style="list-style-type: none"> Heating mode On Heating mode Off
[3]	Fault indicator <ul style="list-style-type: none"> Displays during a fault condition.
[4]	Burner operation <ul style="list-style-type: none"> Displays when the appliance is firing during a CH/DHW mode.
[5]	Internet connected (accessory) <ul style="list-style-type: none"> Displays when compatible controller is connected to the appliance (not used).
[6]	Radio link connected (accessory) <ul style="list-style-type: none"> Displays when compatible controller is connected to the appliance.
[7]	Chimney sweep mode <ul style="list-style-type: none"> Displays during service when the appliance is set to maximum or minimum output.
[8]	Service mode <ul style="list-style-type: none"> Displays when a qualified service engineer is in the service menus.
[9]	Eco mode active <ul style="list-style-type: none"> Displays when in Economy mode (DHW Pre-heat/comfort function is turned off)
[10]	Domestic hot water (DHW) <ul style="list-style-type: none"> Hot water mode On Hot water mode Off

Table 24

6.4.3 Switching on the device

i The appliance is vented after initial power-up. This involves the heating pump switching on and off at intervals (for approx. 13 minutes). and the flow temperature appear alternately in the display.

- ▶ Open automatic air vent valve.

i Automatic siphon fill mode will begin when the appliance is first powered-up. When the flow temperature and the symbol appear alternately on the display, the siphon filling program is active.

6.4.4 Setting the flow temperature

The maximum flow temperature can be adjusted between 30 °C and 82 °C. The current flow temperature is shown on the display.

- ▶ Press the key. The set maximum flow temperature is displayed.
- ▶ Press arrow key or to set the required maximum flow temperature.
- ▶ Press the **OK** key to save. Otherwise the setting will be saved automatically after 3 seconds. The display shows the current flow temperature.

The symbol flashes in the display in heating mode. The symbol also appears if the burner is active.

! WARNING



Risk of scalding!



- ▶ This appliance is supplied with the CH control set at approximately 65 °C, a temperature that should be suitable for most installations that comply with the current building regulations. When the boiler switches from CH to DHW, the temperature of the hot water may briefly exceed the DHW set point if the CH temperature is set higher than the DHW temperature. If the CH temperature is changed to above 65 °C, it is advisable to fit a thermostatic mixing valve (TMV) at the point of use (e.g. before the bath hot tap or shower) to protect vulnerable people from scalding.

6.4.5 Setting the DHW heating

Set DHW temperature

DHW temperature:

- ▶ Press the  key.
The set DHW temperature is displayed.
- ▶ Press arrow key  or  to set the required DHW temperature.
- ▶ Press the **OK** key to save. Otherwise the setting will be saved automatically after 3 seconds.
The display shows the current flow temperature.

The  symbol flashes in the display in DHW mode. The  symbol also appears if the burner is active.



Setting comfort mode or ECO mode

In comfort mode, the appliance is continually maintained at the set temperature (→ service function 3-CA). This means there will be a short delay when drawing DHW. However, the device will switch on even if no DHW is being drawn.

In ECO mode, heating-up to the set temperature begins as soon as the DHW is being drawn.



In Eco mode, to reduce water usage:

- ▶ Briefly open and close the DHW tap.
The water is heated once to the set temperature.
- ▶ To set ECO mode: press  until **eco** appears in the display.
- ▶ To return to comfort mode: press the  key until **eco** vanishes from the display.

6.4.6 Setting the heating control device



Observe the operating instructions of the heating controller. This shows you:

- ▶ how to set the room temperature.
- ▶ how to heat economically and save energy.

6.4.7 After commissioning

- ▶ Complete commissioning report (→ page 98).

6.4.8 Setting summer mode

The heating pump and consequently the heating are switched off in summer mode. The DHW supply and also the power supply for heating controls and timer remain active.



NOTICE

Risk of the system freezing.

Frost protection is not available in summer mode.

- ▶ If there is a risk of frost, exit summer mode (→ Chapter 7.1).

To activate summer mode:

- ▶ Press the  key.
- ▶ Keep pressing the arrow key  until **OFF** appears in the display.
- ▶ Press the **OK** key to save. Otherwise the setting will be saved automatically after 3 seconds.
 is permanently displayed.

Further notices can be found in the operating instructions for the heating control.

6.4.9 Manual mode

Manual mode can be enabled to operate the boiler independent of controls, should there be a technical issue with time and temperature controls fitted.

To activate manual mode:

- ▶ Press and hold the  key for 5 seconds.
- ▶ Check the flow temperature shown and adjust if necessary.
 - The flow temperature will be shown in between two hyphens, indicating manual mode.

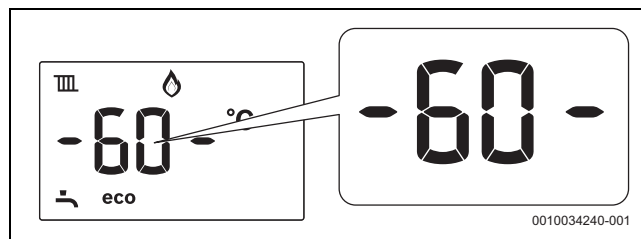



Fig. 64 Manual mode shown on display



Manual mode should be used for a limited time only until the time and temperature controls are fixed.

- ▶ To disable Manual Mode press and hold the  key for 5 seconds.

6.5 Chimney sweep mode



You have 30 minutes to take your measurements or to check or adjust the appliance settings. After this time the appliance returns to normal operation.

Whilst the appliance is in chimney sweep mode, the chimney sweep symbol () will be displayed on the screen.

6.5.1 Setting the appliance to maximum



Maximum output mode

- ▶ A hot water outlet can be opened to prevent the appliance from shutting down due to high temperature during testing.
- ▶ Press the **ok** button for at least 5 seconds.
 - The appliance enters chimney sweep mode and automatically enters maximum output.
 - The display shows the maximum percentage of the power **100%** alternating with the flow temperature.
 - The appliance will ramp up to maximum output in approximately 30 to 35 seconds.

6.5.2 Setting the appliance to minimum

Whilst the appliance is already in chimney sweep mode - maximum output.

- ▶ Press the ▼ button to set the appliance to minimum output.
 - The display shows the minimum percentage of the power alternating with the flow temperature.
 - The appliance will take approximately 30 to 35 seconds to ramp down to minimum output.
 - Allow the appliance to stabilise at minimum output.

6.5.3 Exiting chimney sweep mode

To exit the chimney sweep mode:

- ▶ Press the **ok** button and the appliance will return to normal operation.
 - If left in the chimney sweep mode the control will return to normal operation after 30 minutes.

6.6 Checking gas inlet pressure

Measuring the inlet pressure

- ▶ Switch off the appliance and close the gas isolator.
- ▶ Unscrew the screw on the test nipple for the gas supply pressure and connect a pressure gauge.

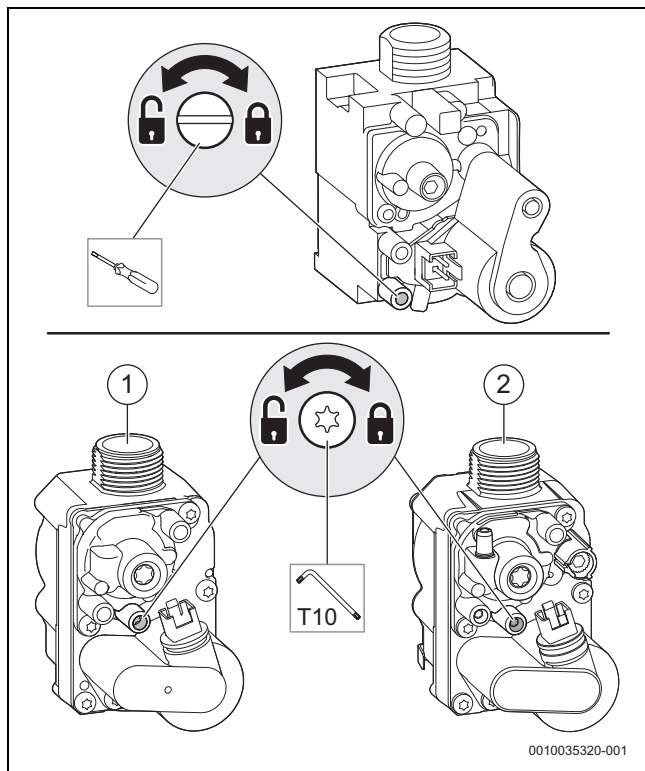

Fig. 65 Checking the gas supply pressure (above: SIT valve, below: Honeywell valves)

- [1] Gas valve - NG
- [2] Gas valve - LPG

- ▶ Open the gas isolator and switch on the appliance.
- ▶ Ensure that there is heat transfer by opening the radiator valves and any zone valves fitted. A hot water tap can also be opened for additional heat transfer.
- ▶ Set the appliance running at maximum output in chimney sweep mode (→ 6.5 "Chimney sweep mode").
- ▶ Check the required gas supply pressure according to following section "Gas pressure within the system".



Commissioning must not take place outside of the permissible pressure range.

- ▶ Identify the cause and rectify the fault.
- ▶ If this is not possible: isolate the device on the gas side and notify the gas supplier.

- ▶ Exit the chimney sweep mode.
- ▶ Switch off the device, close the gas isolator, remove the pressure gauge and tighten the screw.
- ▶ Refit the casing.

Gas pressure within the system



The appliance must be running at maximum output rate when performing the gas rate check, (→ chapter 6.5.1).



Combi appliances

- ▶ Running a hot water tap does not guarantee the boiler will operate at maximum output throughout the test.

Refer to the figures below for Natural Gas and LPG gas pressures.

The pressure drop from the natural gas meter or LPG storage tank to the gas valve inlet test point must not be more than the values stated in table 25.

If the pressure drops are greater than shown in table 25, then this would indicate a problem with the pipe work or connections within the system.

NOTICE

Do not continue commissioning until the correct gas pressure is achieved.

Description	Gas Type	
	Natural Gas	LPG
Meter/LPG Storage Supply pressure [A] (mbar range)	18.5 - 23	32 - 45
Permitted pressure drop [A1] (mbar) ¹⁾	-	0.5
Across pipework permitted pressure drop [B] (mbar)	1	2.5
Appliance inlet [C] (mbar range)	17.5 - 22	29.5 - 42.5
Across appliance permitted pressure drop [D] (mbar)	1.5	1.5
Gas valve inlet test point [E] (mbar range)	16 - 20.5	28 - 41

1) Permitted pressure drop between LPG Storage and the LPG Regulator

Table 25 Allowed mbar pressure drop

Gas supply pressure drop - Natural Gas

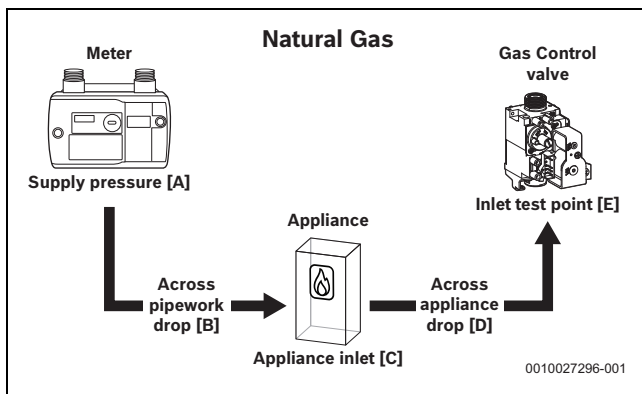

Fig. 66 Natural Gas pressures

Gas supply pressure drop - LPG

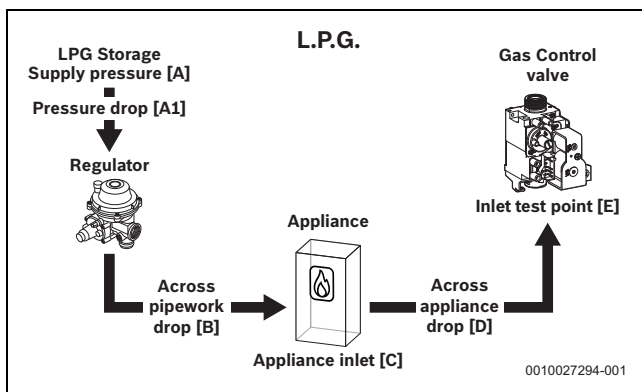



Fig. 67 L.P.G. pressures

6.7 Checking the gas rate

- ▶ The gas rate should be measured at the gas meter after the appliance has been operating for a minimum of 10 minutes at maximum output.
- ▶ Where a gas meter is not available (e.g. LPG) the CO/CO₂ must be checked.
- ▶ Refer to Technical data section of this manual for the appliance gas rates and CO/CO₂ ratios.
- ▶ Gas rate must be checked with the appliance in service, maximum output test mode.
- ▶ Carry out Gas rating procedures as described in current standards.
- ▶ Ensure all other gas appliances are isolated when carrying out the gas rate check on the appliance.



Maximum output mode

- ▶ A hot water outlet can be opened to prevent the appliance from shutting down due to high temperature during testing.
-
- ▶ Ensure all other gas appliances are isolated.
 - ▶ Press the **ok** button until the  symbol appears on the display. The display shows the maximum percentage of the power **100%** alternating with the flow temperature.
 - ▶ Ensure that the appliance has stabilised at maximum output.
 - ▶ If pressure and gas rate are satisfactory press the **ok** button and the appliance will return to normal operation.
 - If left in the service mode the control will return to normal operation after 30 minutes.
 - ▶ Close the gas isolation valve.
 - ▶ Remove the manometer.
 - ▶ Re-seal the screw in the gas inlet pressure test point.
 - ▶ Open the gas isolation valve.
 - ▶ Ensure that there are no gas leaks.

6.8 Checking for gas leaks during operation

- ▶ Use an approved gas sniffer or leak detection fluid to check all connections for possible leaks. Leak detection fluid must be certified as a gas leak testing agent.
- ▶ Do not allow leak detection fluid to come into contact with the electrical components.

6.9 CO and combustion check

The following combustion and flue integrity checks are mandatory and these values must be recorded on the Benchmark check list, at the end of these instructions.

Once the gas rate and pressure have been confirmed as acceptable then the CO and combustion checks can be undertaken.

The flow chart is given for guidance, the details of the checks are given in the following sections:

- Checking flue integrity (→ chapter 6.10).
- Flue gas analysis (→ chapter 6.11).

NOTICE

Before CO and combustion checks:

- ▶ Verify the appliance is connected to the correct gas type.
- ▶ Ensure the appliance is supplied with the correct gas inlet pressure and gas rate as specified previously in the Commissioning section.
- ▶ Visually check the integrity of the whole flue system and confirm that all the components are correctly assembled, fixed and supported.
- ▶ The flue gas analyser must be the correct type as specified in BS 7967. Before use the analyser must have been calibrated as specified by the manufacturer. The installer must be competent in the use of the analyser.
- ▶ Check and zero the analyser in fresh air as specified by the manufacturer.
- ▶ The air/gas ratio valve is factory set and must not be adjusted during commissioning unless this action is recommended following contact with the Worcester, Bosch Group help line 0330 123 3366.

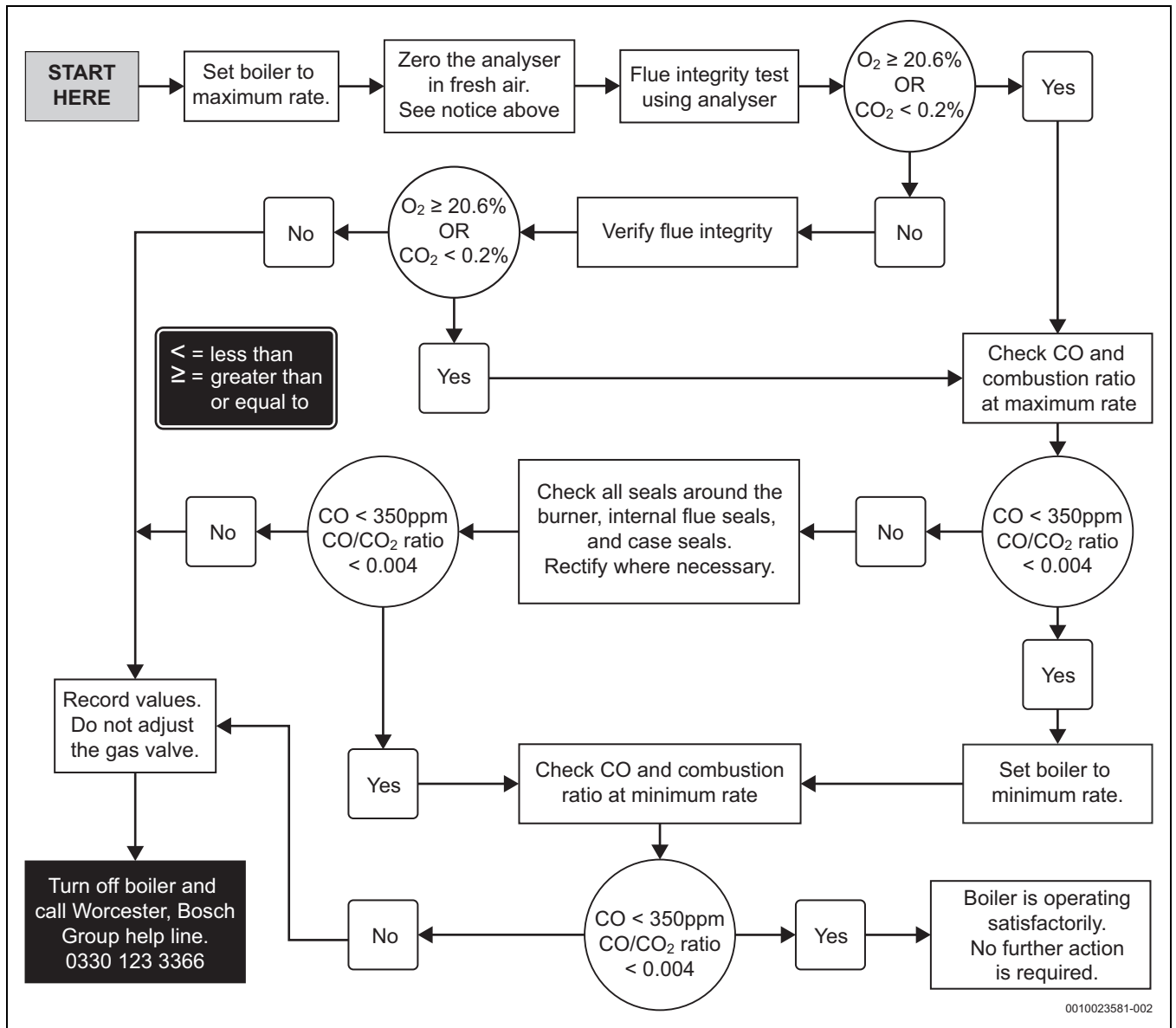

Fig. 68 Commissioning checks flow chart

6.10 Checking flue integrity



Flue integrity check

- ▶ The combustion casing must be fitted whilst this test is carried out.
- ▶ Refit the test point plugs after the test has been completed.

The integrity of the flue system and performance of the appliance can be checked via the flue turret/adaptor sample points.

Air inlet sample point location on flue turret/adaptor.

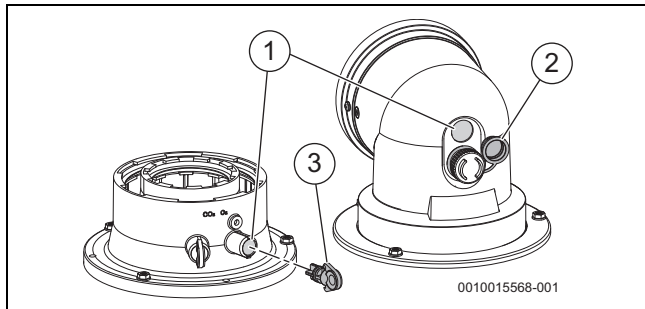

Fig. 69 Flue integrity check test point

- [1] Air inlet sample point
 - [2] Flue turret air inlet blank plug (with retaining ring)
 - [3] Flue adaptor air inlet blank plug
- ▶ With the appliance combustion casing on and the appliance running at maximum output in chimney sweep mode (→ chapter 6.5 "Chimney sweep mode"), remove the blanking plug [2 or 3] for the air inlet sample point [1].
 - ▶ Insert the analyser probe into the air inlet sample point [1].
 - ▶ Allow the readings to stabilise and check that:
 - O₂ is equal to, or greater than 20.6%
 - CO₂ is less than 0.2%
 - ▶ If the readings are outside these limits then this indicates that there is a problem with the flue system or combustion circuit.

6.11 Flue gas analysis

NOTICE

Combustion testing

- ▶ Combustion testing must be carried out by a competent qualified person. Testing must not be attempted unless the person carrying out the combustion check is equipped with a calibrated Flue Gas Analyser conforming to BS 7967 and is competent in its use.



Flue gas analysis

- ▶ Ensure that the gas inlet pressure has been checked and is satisfactory.
- ▶ Refit the test point plugs after the test has been completed.

The flue gas analysis performance of the appliance can be checked via the flue turret/adaptor sample points.

Refer to figure 70 for the location of the flue gas sample point on flue turret/adaptor.

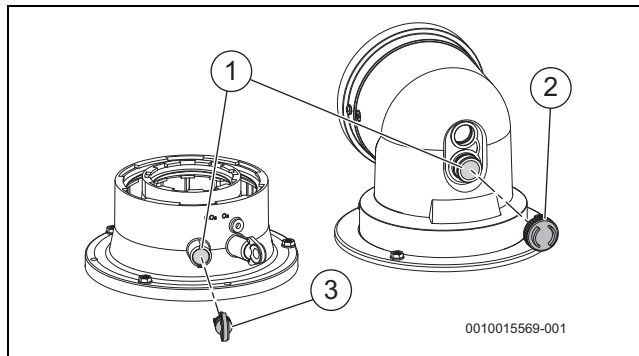

Fig. 70 Combustion test

- [1] Flue gas sample point
- [2] Flue turret flue gas blank plug
- [3] Flue adaptor flue gas blank plug

The CO and combustion ratio are checked;

- In chimney sweep mode at maximum output.
- In chimney sweep mode at minimum output.

Appliance to maximum output

- ▶ Set the appliance running at maximum output in chimney sweep mode (→ chapter 6.5 "Chimney sweep mode").

Appliance to minimum output

- ▶ Set the appliance running at minimum output in chimney sweep mode (→ chapter 6.5 "Chimney sweep mode").
 - Allow the appliance to stabilise at minimum output.

Measuring the CO and combustion ratio.

- ▶ Remove the blanking plug [2 or 3] for the flue gas sample point [1].
- ▶ Insert the analyser probe into the flue gas sample point [1].
 - Ensure that the probe reaches the centre of the flue gas exhaust, adjust the cone on the probe so that it seals the sample point and correctly positions the end of the probe.
- ▶ Check the CO and combustion readings.

6.12 Finishing commissioning

6.12.1 Fitting the front panel

- ▶ Fit the front panel making sure that the securing points are properly located.
 - Lift the front panel onto the locating bracket on the top of the appliance.
 - Push the bottom of the panel into position and tighten the bottom two screws [1].

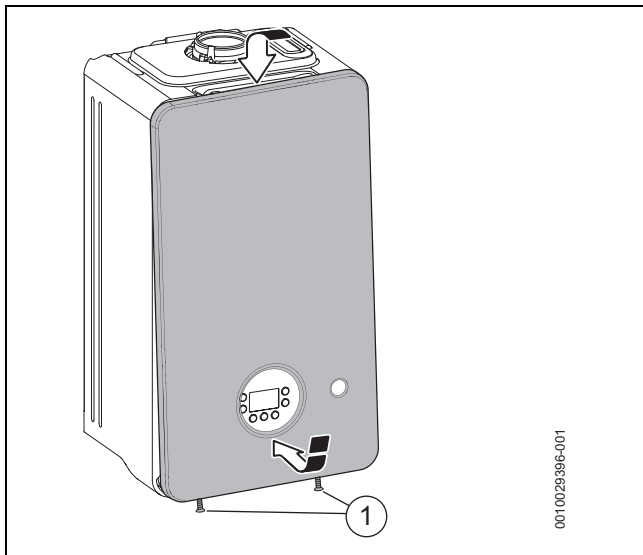

Fig. 71 Fitting the front panel

6.12.2 Fitting the infills

- ▶ Assembly of infills.
 - Please do not forget to fit the infills [1] after installation of appliance.

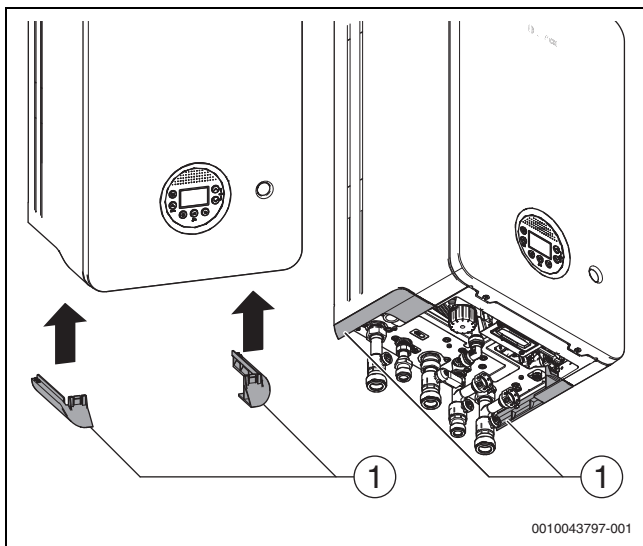

Fig. 72 Assembly direction of infills



Appliance operation.

- ▶ For details on operating the appliance and control panel overview, refer to the User Instructions.



At the time of commissioning, complete all relevant sections of the Benchmark Checklist located in the Technical Specifications/Logs section of this document.

Appliance handover:

- ▶ Complete the Benchmark Gas Boiler Commissioning Checklist.
- ▶ Show the customer the special features of the appliance.
- ▶ Show the customer the efficiency tips in the User Instructions.
- ▶ Set up the appliance controls and show the customer how to operate all the control unit/s for central heating and DHW operation.
 - Also show where in the appliance/controls documentation where this information can be found.
- ▶ Where applicable, instruct the customer on:
 - how to check the system pressure and re-pressurise if necessary.
 - how to set the TRVs.
 - how to reset the appliance.
- ▶ Show the customer the fault finding section in the User Instructions.
- ▶ Show the customer where the serial number/appliance information is located, they will need this information if they call in with a problem (Benchmark Commissioning checklist on page 98 contains all relevant appliance information).
- ▶ Give the customer details of how to contact the installer/ gas emergency numbers.
- ▶ Show the customer how to safely isolate the appliance.
- ▶ Advise the customer where they can find information on the Worcester, Bosch Group website www.worcester-bosch.co.uk.
- ▶ Ensure that all documentation, is left with the appliance or homeowner.
 - Appliance documentation.
 - Controls documentation.
 - Any other equipment documentation that is connected to the appliance or system.
- ▶ Appliance not in use
 - If the appliance is not going to be used immediately and may be exposed to freezing conditions, advise the customer of the precautions necessary to prevent damage to the appliance, system and building.
 - If the appliance is unused and exposed to freezing conditions, safely isolate all the mains supplies and drain the system and appliance, label accordingly.
- ▶ Show the customer the location of the condensate pipe run in unheated or external areas that may be at risk of freezing during prolonged cold spells.
- ▶ **User recommendation:**
 - Advise the user to have the appliance and heating system thoroughly serviced annually by a competent, registered gas engineer, such as a Gas Safe registered engineer or British Gas engineer.
 - Present, where relevant, maintenance aids and reminders within the appliance menus.
 - Arrange an inspection/maintenance contract with an approved heating contractor.

6.12.3 Appliance/product guarantee

This appliance/product has a guarantee against faulty materials or workmanship for a period from the date of installation subject to the terms and conditions.

For full terms and conditions, please visit:

www.worcester-bosch.co.uk/guarantee-terms-and-conditions

Guarantee registration

Your appliance/product carries a guarantee against faulty material or manufacture subject to Terms and Conditions.

To read the full Terms & Conditions please visit us on-line at www.worcester-bosch.co.uk/guarantee.

Your statutory rights are not affected by the manufacturer's guarantee.

7 Shutdown

7.1 Setting frost protection

NOTICE

Risk of damage to the system from frost!

The heating system can freeze up after a prolonged period (e.g. during a power failure, switching off the power supply, faulty fuel supply, boiler fault etc.).

- ▶ Ensure that the heating system is in constant use (particularly when there is a risk of frost).

Frost protection for the heating system:

Always follow the latest advice in BS7593 for system frost protection.

Frost protection for the heating system is only ensured if the heating pump is operational and is pumping heating water through the entire system.

- ▶ Leave the heating switched on.
- ▶ Set the time control to constant ON and set the room thermostat to 12 °C.

-or- If you want to leave the appliance switched off:

- ▶ Mix Worcester-approved anti-freeze into the heating water (→ "Water treatment products", page 35) and drain the DHW circuit.



For further information, see the heating controller operating instructions.

Appliance frost protection:

The appliance frost protection function switches the burner and heating pump on when the appliance temperature falls below 5 °C. This prevents the appliance from freezing.

7.2 Anti-seize protection



This function prevents the heating pump and the diverter valve seizing up following long periods of inactivity.

The anti-seizing function remains active during standby mode.

The pump is briefly activated automatically after 24 hours of inactivity.

8 Settings in the service menu

Many appliance functions can be set and checked in the service menu. It includes:

- Menu 1: information menu
- Menu 2: not used in UK
- Menu 3: factory settings
- Menu 4: special features
- Menu 5: limit values
- Menu 6: function checks
- Menu 0: manual operation

8.1 Operating the service menu

Selecting and setting the service function



If a key is not pressed for 30 minutes, the system exits the selected service function automatically.

- ▶ To select a service function, press arrow key ▲ or ▼. The display shows the service function.
- ▶ To confirm the selection: press **OK** key. The current setting starts to flash.
- ▶ To change the setting: press arrow key ▲ or ▼.
- ▶ To save: press **OK** key.
- or-
- ▶ If you do not want to save the setting: press ↶ key. The value currently set is displayed.
- ▶ Press the ↶ key. The service function is displayed.
- ▶ Press ↶ key again. The higher level menu is displayed.
- ▶ Press ↶ key again. The device reverts to normal operation.

Documenting the settings

- ▶ Record the change the settings in the commissioning report (→ Section 13.6).

Settings in the service menu

Many appliance functions can be set and checked in the service menu.

Opening the service menu

- ▶ Press the DHW key and the Heating key simultaneously until the service menu appears.

Closing the service menu

- ▶ Press the DHW key or the Heating key.

-or-

- ▶ Press the ↶ key.

Navigating through the menu

- ▶ To highlight a menu or a menu item, press the ▲ key or the ▼ key.
- ▶ Press **OK** key. The menu or the menu item is displayed.
- ▶ To return to the next higher menu level, press the ↶ key.

Changing the settings values

- ▶ Select the menu item with the **OK** key.
- ▶ To select the desired value, press the ▲ key or the ▼ key. The new value will be saved after 5s or after pressing the **OK** key.

Exiting the menu item without saving values

- ▶ Press the ↶ key. The value is not saved.

8.2 Service functions overview

8.2.1 Menu 1

- ▶ Press the **||||** key and **↩** key at the same time until **L.1** appears.
- ▶ To confirm the selection: press **OK** key.
- ▶ Selecting and setting the service function.

Service function	Unit	Further information
1-A1	Current operating status	Status code, → Section 11.2
1-A2	Current fault	Error code, → Section 11.2
1-A3	Upper limit of the maximum heat output	% The maximum heat output can be decreased via the service function 3-b1.
1-A5	Temperature at flow temperature sensor	°C –
1-A6	Set flow temperature	°C –
1-b2	Current turbine flow rate	l/min –
1-b3	Current DHW temperature	°C –
1-b4	Current DHW outlet temperature	°C –
1-b5	Current temperature at the cylinder	°C –
1-b7	Set DHW temperature	°C –
1-b8	Current thermal output as a % of the maximum rated heat output in heating mode	% During DHW heating, values greater than 100 % may be displayed.
1-C1	Ionisation current	µA • Minimum burner operation or greater: $\geq 2 \mu\text{A}$ = OK, $< 2 \mu\text{A}$ = faulty • While the burner is switched off: $< 2 \mu\text{A}$ = OK, $\geq 2 \mu\text{A}$ = faulty
1-C2	Current pump output as % of rated pump output	–
1-C4	Current outside temperature with outside temperature sensor connected	°C –
1-C5	Temperature at the solar buffer cylinder	°C Only displayed when a solar module is connected.
1-C6	Operating pressure	bar –
1-d1	Collector temperature	°C Only displayed when a solar module is connected.
1-d2	Temperature at the solar buffer cylinder (bottom)	°C Only displayed when a solar module is connected.
1-d3	Solar pump	% Only displayed when a solar module is connected.
1-d4	Solar unit fault	Only displayed when a solar module is connected. Error code
1-E1	Software version of the control panel (main version)	–
1-E2	Software version of the control panel (secondary version)	–
1-E3	Coding plug number	–
1-E4	Coding plug version	–
1-EA	Software version of device electronics (main version)	–
1-Eb	Software version of device electronics (secondary version)	–

Table 26 Menu 1: display of information

8.2.2 Menu 2

- ▶ Press the **||||** key and **↩** key at the same time until **L.1** appears.
- ▶ Press arrow key **▲** until **L.2** is displayed.
- ▶ To confirm the selection: press **OK** key.
- ▶ Selecting and setting the service function.



The basic settings are depicted as **highlighted** in the following table.

Service function	Settings/adjustment range	Remark/restriction
2-A1	Low-loss header • 0 : no low loss header installed • 1: (not available) • 2: low loss header connected to the module	This setting defines where the sensor of the low loss header is connected.

Table 27 Menu 2: hydraulic settings

8.2.3 Menu 3

- ▶ Press the **||||** key and **↩** key at the same time until **L.1** appears.
- ▶ Press arrow key **▲** until **L.3** is displayed.
- ▶ To confirm the selection: press **OK** key.
- ▶ Selecting and setting the service function.



The basic settings are depicted as **highlighted** in the following table.

Service function	Settings/adjustment range	Remark/restriction
3-b1 Maximum approved heat output	<ul style="list-style-type: none"> • GR2301iW 25 C : 50 ... 80 % • GR2301iW 30 C : 50 ... 68 % 	<ul style="list-style-type: none"> ▶ Set heat output in percent. ▶ Measure gas flow rate. ▶ Compare measured result with the setting tables (→ page 97). Correct the setting in the case of any deviation.
3-b2 Time interval between stopping and starting the burner in heating mode	• 3 ... 10 ... 60 minutes	<p>The time interval specifies the minimum waiting time between switching on the burner and switching it on again.</p> <p>If a weather-compensated heating controller is connected, this setting is optimised by the heating controller.</p>
3-b3 Temperature interval for switching the burner off and back on	• -15 ... -6 ... -2 K (°C)	<p>The difference between the current flow temperature and the set flow temperature until the burner is switched on.</p> <p>If a weather-compensated heating controller is connected, this setting is optimised by the heating controller.</p>
3-C4 Turbine signal delay	• 2 ... 16 × 0.25 seconds	The delay prevents sudden changes in the water supply pressure from causing the burner to briefly operate although no water is drawn off.
3-C5 Delay of DHW mode (solar mode)	• 0 (not active) ... 50 seconds	<p>DHW mode will be suppressed until the DHW temperature sensor detects that the water preheated by solar energy has reached the desired DHW temperature.</p> <ul style="list-style-type: none"> ▶ Set the DHW mode delay according to the system conditions.
3-C6 Time interval between stopping and restarting the burner for DHW heating (only in comfort mode and summer mode)	• 0 ... 30 minutes	After DHW is drawn off, the DHW heating remains disabled for this period.
3-C8 Thermal disinfection up to draw-off point	<ul style="list-style-type: none"> • OFF: switched off • ON: switched on 	<p>If too much water is drawn off, the required temperature may not be reached.</p> <ul style="list-style-type: none"> ▶ Only draw off enough water to allow the DHW temperature of 70 °C to be reached. ▶ Perform thermal disinfection (→ Instructions for the user).
3-CA DHW mode	<ul style="list-style-type: none"> • 0: comfort mode, the device is continually kept at the set temperature. • 1: ECO mode, only heat-up to the selected temperature when hot water is being drawn. • 2: (not available) • 3: (not available) 	Short waiting time in comfort mode, when domestic hot water is extracted. The device therefore switches on, even if no domestic hot water is extracted.
3-D3 Minimum pump speed adjustment	• 40 ... 100%	In order to save as much energy as possible and the minimize the possibility of water circulation noise, pump speed minimum and maximum values can be adjusted according to the estimated system restrictions of the installation place.
3-D4 Maximum pump speed adjustment	• 40 ... 100%	
3-d6 Overrun time of the heating pump in heating mode	<ul style="list-style-type: none"> • 1 ... 3 ... 60 minutes • 61: 24 hours 	The pump overrun begins at the end of the heat demand by the heating controller.

Table 28 Menu 3: factory settings

8.2.4 Menu 4

- ▶ Press the **||||** key and **↩** key at the same time until **L.1** appears.
- ▶ Press arrow key **▲** until **L.4** is displayed.
- ▶ To confirm the selection: press **ok** key.
- ▶ Selecting and setting the service function.



The factory settings are **highlighted** in the following table.

Service function	Settings/adjustment range	Remark/restriction
4-A1 Venting function	<ul style="list-style-type: none"> • 0: switched off • 1: automatic (Ventilation is carried out once. At the end of ventilation, the setting reverts to the "Deactivated" status.) • 2: permanently switched off (The setting is retained until the operation mode changes.) 	<p>The venting function can be switched on after maintenance work.</p> <p>During ventilation, the  symbol and flow temperature appear alternately in the display.</p>
4-A2 Siphon filling program	<ul style="list-style-type: none"> • 0: switched off (only permissible during maintenance) • 1: switched on with minimum power • 2: switched on with minimum heat output 	<p>The siphon filling program is activated in the following cases:</p> <ul style="list-style-type: none"> • The device is switched on at the On/Off switch. • The burner was not in operation for at least 28 days. • The operating mode is switched from summer to winter mode. <p>The next time there is a heat demand in heating or cylinder mode, the heat output of the device is kept low for 15 minutes.</p> <p>The  symbol and flow temperature appear alternately in the display for the duration of the siphon filling program.</p>
4-A4 Service display	<ul style="list-style-type: none"> • 0: switched off • 1: acc. to hours run • 3: acc. to elapsed time 	
4-A5 Inspection interval according to hours run	<ul style="list-style-type: none"> • 10 ... 60 × 100 hours 	<p>This service function is only available if service function 4-A4 is activated. (=01)</p> <p>After this interval has expired, the display indicates that an inspection is due via the service display 1018.</p>
4-A6 Inspection interval according to elapsed time	<ul style="list-style-type: none"> • 1 ... 72 months 	<p>This service function is only available if service function 4-A4 is activated. (=03)</p> <p>After this interval has expired, the display indicates that an inspection is due via the service display 1018.</p>
4-b1 Device-internal weather-compensated control	<ul style="list-style-type: none"> • OFF: not active • ON: active 	<p>This service function is only available if an outside temperature sensor is detected in the system.</p> <p>This service function is no longer available when a weather-compensated control unit with EMS connection is connected.</p>
4-b2 Outside temperature limit for automatic changeover between summer and winter mode.	<ul style="list-style-type: none"> • 0 ... 16 ... 30 °C 	<p>This service function is only available if service function 4-b1 is activated.</p> <p>If the outside temperature exceeds the set temperature limit, the heating is switched off (summer mode). If the outside temperature falls to at least 1 K (°C) below the setting, the heating is switched back on (winter mode).</p>
4-b3 End point of the heating curve for weather-compensated control	<ul style="list-style-type: none"> • 20 ... 90 °C 	<p>This service function is only available if service function 4-b1 is activated.</p> <p>Set flow temperature for an outside temperature of - 10 °C (→ heating curve, page 95).</p>
4-b4 Base point of the heating curve for weather-compensated control	<ul style="list-style-type: none"> • 20 ... 90 °C 	<p>This service function is only available if service function 4-b1 is activated.</p> <p>Set flow temperature for an outside temperature of + 20 °C (→ heating curve, page 95).</p>

Service function		Settings/adjustment range	Remark/restriction
4-b5	Device frost protection	<ul style="list-style-type: none"> • OFF: switched off • ON: switched on 	<p>This service function is only available if service function 4-b1 is activated.</p> <p>The device frost protection function switches the burner and heating pump on when the outside temperature falls below 5 °C. This prevents the wall mounted boiler freezing.</p>
4-b6	Temperature value for the system frost protection	• 0 ... 5 ... 10 °C	<p>This service function is only available if the frost protection function (service function 4-b1) was activated.</p> <p>If the outside temperature does not exceed the frost threshold temperature, then the heating pump in the heating circuit switches on (system frost protection).</p>
4-F1	Reset device to basic setting	• YES: device is reset to factory settings	
4-F2	Reset the fault display	<ul style="list-style-type: none"> • NO: fault is retained • YES: fault is reset 	

Table 29 Menu 4: settings

8.2.5 Menu 5

- ▶ Press the **||||** key and  key at the same time, until **L.A** is displayed.
- ▶ Keep pressing the arrow key **▲**, until **L.5** is displayed.
- ▶ To confirm the selection: Press the **OK** key.
- ▶ Select and set the service function.



The basic settings are depicted as **highlighted** in the following table.

- ▶ These settings will not be reset during a factory reset.

Service function L.5		Settings/adjustment range	Remark/restriction
5-A1	Maximum flow temperature	• 30 ... 82 °C	Limits the adjustment range for the flow temperature.
5-A2	Maximum DHW temperature	• 35... 60 ... 80 °C	Limits the adjustment range for the hot water (not applicable on combination appliances.).
5-A3	Minimum boiler output (heating and DHW)	<ul style="list-style-type: none"> • GR2301iW 25 C : 19 ... 49% • GR2301iW 30 C : 16 ... 49% 	Minimum heat output.

Table 30 Menu 5: Limit values

8.2.6 Menu 6

- ▶ Press the **||||** key and **↵** key at the same time until **L.1** appears.
- ▶ Press arrow key **▲** until **L.6** is displayed.
- ▶ To confirm the selection: press **OK** key.
- ▶ Selecting and setting the service function.



The basic settings are depicted as **highlighted** in the following table.

Service function	Settings/adjustment range	Remark/restriction
6-t1 Permanent ignition	<ul style="list-style-type: none"> • OFF: switched off • ON: switched on 	Testing the ignition by means of permanent ignition without gas supply. <ul style="list-style-type: none"> ▶ To prevent damage to the ignition transformer: Leave the function switched on for a maximum of 2 minutes.
6-t2 Permanent fan operation	• 0 ... 100 %	Fan running without gas supply or ignition.
6-t3 Permanent pump operation (heating pump)	• 0 ... 100 %	If a value >0 is set, the pump runs with 100 %.
6-t5 3-way valve permanently in the DHW heating position	<ul style="list-style-type: none"> • 0: heating • 1: DHW • 2: (not available) 	
6-tA Ionisation oscillator	<ul style="list-style-type: none"> • OFF: switched off • ON: switched on 	
6-tb Burner test	• 0 ... 100 %	The burner test is ended by resetting the setting value to 0, or by exiting L.5.

Table 31 Menu 6: function checks

8.2.7 Menu 0

- ▶ Press the **||||** key and **↵** key at the same time until **L.1** appears.
- ▶ Press arrow key **▲** until **L.0** is displayed.
- ▶ To confirm the selection: press **OK** key.
- ▶ Selecting and setting the service function.



The basic settings are depicted as **highlighted** in the following table.

Service function	Settings/adjustment range	Remark/restriction
0-A1 Manual operation	<ul style="list-style-type: none"> • OFF: switched off • ON: switched on 	
0-A2 Set temperature in manual operation	• 30 ... 60 ... 82 °C	

Table 32 Menu 0

9 Inspection and maintenance

DANGER

Risk of electric shock!

- ▶ Isolate electrical components from the power supply (230 V AC) (fuse, circuit breaker) and secure against unintentional re-connection before carrying out any work. Information on safe isolation can be found in the Health and Safety Executive guidance HSG85.
- ▶ Check for zero potential before proceeding with work, using test equipment approved to GS38 to confirm that the electricity supply is disconnected.

CAUTION

Mains supplies:

- ▶ Safely isolate both the gas and electrical supply before starting any work on the appliance and observe all relevant safety precautions.

NOTICE

Personnel and equipment

- ▶ Any service work must be carried out by competent registered engineers.
- ▶ Service work must not be attempted if a calibrated CO/CO₂ analyser and manometer are not available.

WARNING

Hot surfaces!

If the appliance has been operating components may be hot.

- ▶ Ensure precautions are taken when working on the appliance.

CAUTION

Annual maintenance checks:

Annual maintenance checks have to be conducted to ensure the continued safe and reliable operation of the boiler.

- ▶ During each maintenance check, the gas valve, all gas joints and test points should be checked for leakage using an analyser/sniffer.
- ▶ If a leak is found on the gas valve then it needs replacing as a gas valve is a non-repairable component.

CAUTION

Component replacement:

- ▶ After replacement of a gas related component, where a gasket or seal has been disturbed or replaced, check for gas tightness using a gas sniffer/analyser.
- ▶ Also after re-assembly, carry out the following checks:
 - Fan pressure.
 - Flue gas analysis.

9.1 Safety-relevant components

Safety-relevant components (e.g. air/gas ratio control valves) have a limited service life, which depends on their operating time in switching cycles or years.



If the operating time is exceeded or due to increased wear, the affected component may fail and the system safety may be lost.

- ▶ Do not repair, manipulate or disable safety-relevant components.
- ▶ Check safety-relevant components during every inspection and maintenance to determine the continued safety of the system.
- ▶ Replace safety-relevant components in the event of increased wear or at the latest when they have reached the end of their service life.
- ▶ Only use new and undamaged original spare parts for replacement.

Component	Check
Air/gas ratio control valve	<ul style="list-style-type: none"> ▶ Check the air/gas ratio control valve housing for external gas tightness using an analyser certified for gas testing. ▶ Confirm the external gas tightness of the air/gas ratio control valve separately in the inspection and maintenance log.

Table 33 Checking safety-relevant components

9.2 Inspection and maintenance considerations

- To ensure continued efficient operation the appliance must be checked at regular intervals.
- The frequency of servicing will depend upon the particular installation conditions and usage, however, at least an annual service is recommended.
- The extent of the service work required on the appliance is determined by the operating condition of the appliance when tested by qualified engineers.
- After each service, the service interval record sheet at the rear of this manual, must be completed.

See the following instructions for detail of some of the service requirements:

- ▶ Check all joints and connections in the system and remake any that show signs of leakage. Refill and re-pressurise if applicable as described in the commissioning section.
- ▶ When it is frequently necessary to add water to maintain pressure in the installation, even though no leaks have been discovered, perform an expansion vessel check.
- ▶ Check that the condensate system is not obstructed, clean and refill the condensate siphon.
- ▶ If the appliance is in a compartment or cupboard check that the specified clearances around the appliance is clear.
- ▶ Check that the flue system is unobstructed and undamaged, clean/replace as necessary.
 - If fitted ensure the flue terminal guard is also unobstructed and undamaged.
- ▶ Operate the appliance and take note of any irregularities.
 - Refer to the fault finding pages for rectification procedure.

Maximum system pressure

- ▶ 2.5 bar must not be exceeded when the heating system water is at maximum temperature. If this pressure is exceeded then an additional expansion vessel must be fitted into the system return as close as possible to the appliance.
- ▶ If the system does not retain the pressure, the pressure relief valve (PRV) and the heating system should be checked for leaks.

9.3 Service functions

i
An overview of the faults can be found from page 78.

9.4 Component access

Removing the front casing

i
The front casing is secured with two screws which are critical to maintain the case seal and to prevent unauthorised removal (electrical safety).

- ▶ Always secure the casing with these screws.
- ▶ Loosen the two screws [1] and pull the bottom of the casing forward.
- ▶ Lift off the casing.

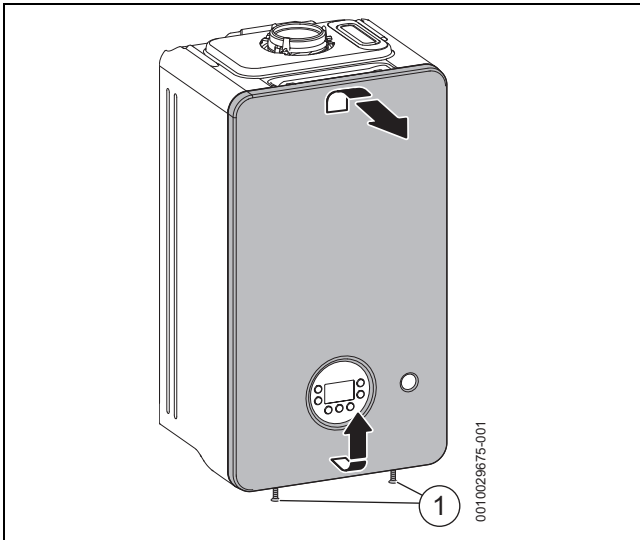

Fig. 73 Removing the front casing

9.5 Fan pressure test

NOTICE

Fan pressure test

- ▶ The appliance must be running at maximum output in chimney sweep mode for the fan pressure test (→ Setting the appliance to maximum).

i
This test is to determine if the heat exchanger requires cleaning or additional actions.

i
Fan pressure test reading.

- ▶ The pressure reading will be in negative values.

9.5.1 Checking heat exchanger assembly

- ▶ Remove the front casing.
- ▶ Remove the cap from the test nipple, and connect a pressure gauge.

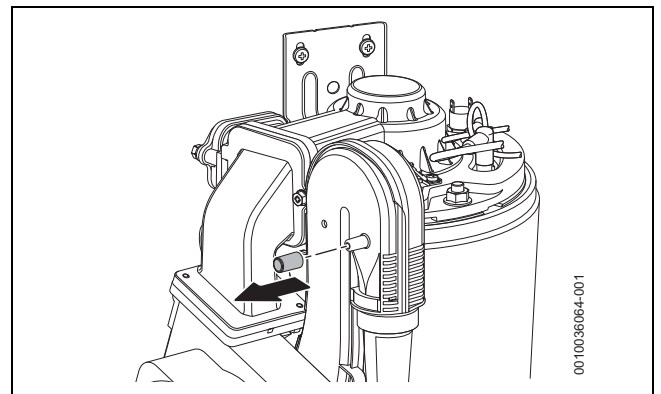

Fig. 74 Test nipple at the mixing device

Appliance fan pressure test values

Natural Gas and LPG appliances

Appliance output	Cleaning required		No cleaning required	
	Value			
30kW	0 mbar	↔ -4.7 mbar	-4.8 mbar	⇒ -12 mbar
25kW	0 mbar	↔ -3.2 mbar	-3.3 mbar	⇒ -12 mbar

Table 34 Natural Gas and LPG values

If the manometer reading is within tolerance, in the white area of the table values.

- ▶ The heat exchanger/exhaust path/siphon does not require attention.

If the manometer reading is out of tolerance, in the shaded area of the table values then carry out the following checks.

- ▶ Check that the siphon is not restricted or blocked.
- ▶ Check the exhaust paths for restrictions.
- ▶ Clean the heat exchanger with a suitable cleaning tool, refer to cleaning section.
- ▶ Re-check the fan pressure readings.
If the appliance, after completing the above checks, fails the fan pressure test then contact Worcester, Bosch Group for advice.
- ▶ Switch the appliance off after completing pressure check.
- ▶ Disconnect the digital manometer and replace the test point cover.

9.6 Check working gas inlet pressure

NOTICE

Gas inlet pressure

- ▶ Do not continue with the other checks if the correct gas inlet pressure can not be achieved at maximum output.

- ▶ Check the gas supply working pressures in the system conform to the readings shown in the table shown in chapter 6.6 "Checking gas inlet pressure".

9.7 Flue gas analysis

NOTICE

Combustion testing

- ▶ Combustion testing must be carried out by a competent person. Testing must not be attempted unless the person carrying out the combustion check is equipped with a calibrated flue gas analyser conforming to BS 7967 and is competent in its use.



Flue gas analysis

- ▶ Ensure that the gas inlet pressure has been checked and is satisfactory.
- ▶ Refit the test point plugs after the test has been completed.

- ▶ Set the appliance to maximum and minimum output in chimney sweep mode (→ 6.5 "Chimney sweep mode") for the flue gas analysis checks.
- ▶ Check that the readings conform to those given in the following tables. In addition to CO and CO/CO₂ ratio checks also check the maximum and minimum CO₂ percentage reading.

Appliance combustion contents settings

CO ₂ Reading	CO Reading
Natural Gas - Maximum rated Output ¹⁾	
Between 9.0 and 10.8%	<250ppm
Natural Gas - Minimum rated Output	
A minimum of 0.6 lower than the maximum reading taken but above 8.2%	<250ppm

1) Should be measured 10 minutes after firing the appliance

Table 35 CO₂ settings

CO ₂ Reading	CO Reading
LPG - Maximum rated Output ¹⁾	
Between 10.6 and 11.0%	<250ppm
LPG - Minimum rated Output	
A minimum of 0.3 lower than the maximum reading taken but above 10.2%	<250ppm

1) Should be measured 10 minutes after firing the appliance

Table 36 CO₂ settings

If the CO₂ is out of tolerance then please check:

- ▶ The gas inlet pressure.
- ▶ The gas rate.
- ▶ The fan test pressure.
- ▶ The flue and air intake, plus any possible blockages in the condensate disposal.
- ▶ The condition of burner.
- ▶ For leaks or obstructions in the exhaust paths.
- ▶ That the injector is clean.

After all checks have been completed and the CO₂ is still out of tolerance then contact Worcester, Bosch Group helpline 0330 123 3366 before making any adjustment to the gas valve.

9.8 Checking the flue integrity

NOTICE

- ▶ Check flue joints are secure, the terminal and the terminal guard, if fitted are clear and undamaged.
- ▶ Combustion testing must be carried out to BS 7967 by a competent person. Testing must not be attempted unless the person carrying out the combustion check is equipped with a calibrated Combustion Analyser conforming to BS EN 50379 and is competent in its use.



Flue gas analysis

- ▶ Ensure that the gas inlet pressure has been checked and is satisfactory.
- ▶ Refit the test point plugs after the test has been completed.

- ▶ Refer to chapter 6.10 "Checking flue integrity" and check that the readings conform to those given, confirming flue system and combustion circuit are ok.

9.9 Cleaning the siphon and heat exchanger

! WARNING

Gaskets and seals - gas related components

- ▶ Burner/electrode assembly gasket must be replaced if disturbed.
- ▶ Other gaskets/seals must be checked and replaced where necessary.
- ▶ Do not attempt the cleaning procedure unless new gaskets and seals are available.

9.9.1 Cleaning the heat exchanger

i

There is an optional tool available to assist in cleaning the heat exchanger, part number 7 733 600 091.

Checking the electrodes and cleaning the heat exchanger

! CAUTION

Risk of burns due to hot surfaces!

Individual components of the appliance can become very hot even after being shut down for a long time.

- ▶ Allow the appliance to cool down before carrying out any work.
- ▶ If necessary, wear protective gloves.

! WARNING

Material damage due to hot flue gas! - Gaskets and seals - gas related components

Hot flue gas can leak through defective gaskets, damage the appliance and endanger safe operation.

- ▶ Burner/electrode assembly gasket must be replaced if disturbed.
- ▶ Other gaskets/seals must be checked and replaced where necessary.
- ▶ Do not attempt the cleaning procedure unless new gaskets and seals are available.
- ▶ Ensure that the gaskets are positioned correctly.

NOTICE

Material damage due to chemicals

Using chemicals during the cleaning of the heat exchanger assembly and associated parts or carrying out maintenance can damage the sealing components. This can cause exhaust gas to escape during operation.

- ▶ Do not use chemicals to flush the heat exchanger assembly and associated gas carrying components.

i

It is recommended to use the cleaning tool accessory, comprising of brush and lifting tool to assist in cleaning the heat exchanger assembly. Part number part number 7 733 600 091.

Refer to figure 75.

- ▶ Disconnect the electrical connection [1] from the fan.
- ▶ Remove the gas hose [2] from the venturi nozzle.
- ▶ Remove the screw [3] on the mixing device.
- ▶ Remove the fan with mixing device [4].

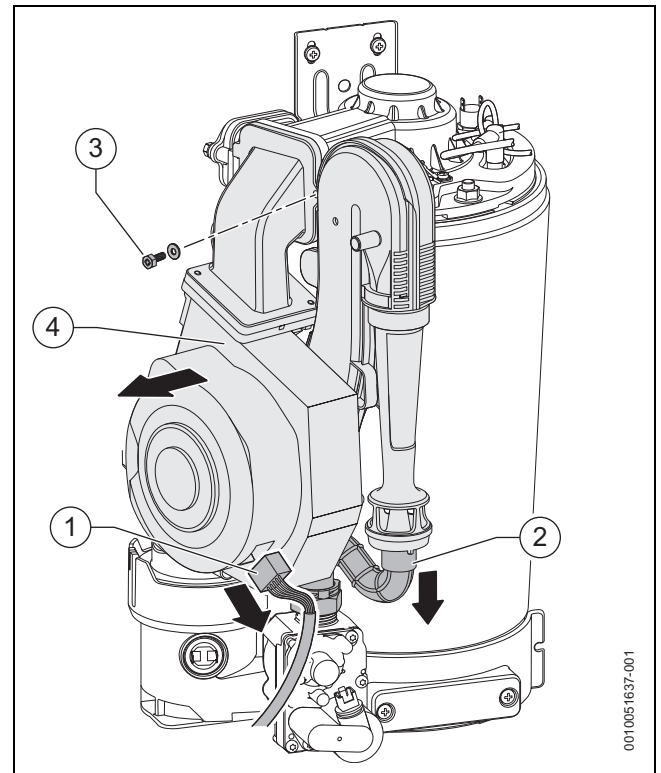

Fig. 75 Removing the fan with mixing unit

Refer to figure 76.

- ▶ Disconnect cables from the electrode set [1].
- ▶ Disconnect hose [2].
- ▶ Remove M8 nut [3].
- ▶ Remove the burner cover [4].

i

On re-assembly, to ensure a full gas tight seal, tighten the M8 nut down firmly, without over tightening.

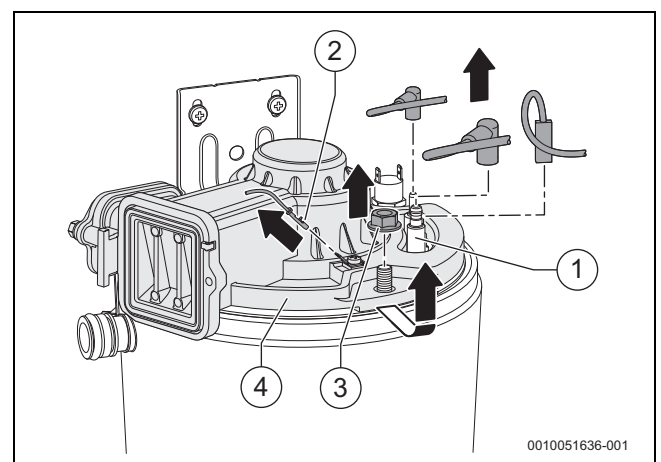

Fig. 76 Remove the burner cover

Refer to figure 77.

- ▶ Remove the non-return valve (bearing plate) [1].
 - Check for damage/cracks or deformation and for contamination, replace if required.
 - Ensure non-return valve moves freely.

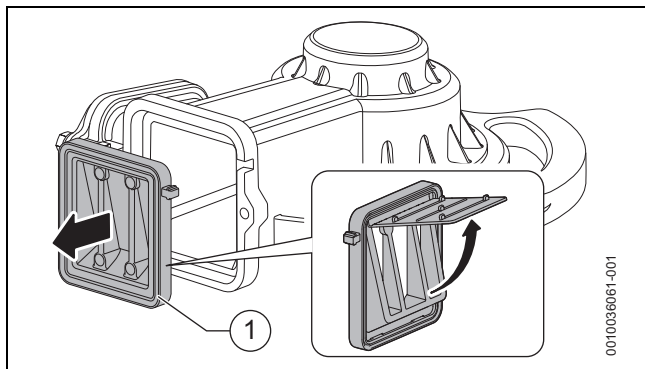

Fig. 77 Non-return valve (bearing plate) in the mixing unit

Refer to figure 78.

- ▶ Remove the gasket [1].
- ▶ Remove electrode set [2].
 - Check for damage or deformation, replace if required.
 - Check electrodes for contamination, clean or replace, if required.
- ▶ Remove the burner [3].

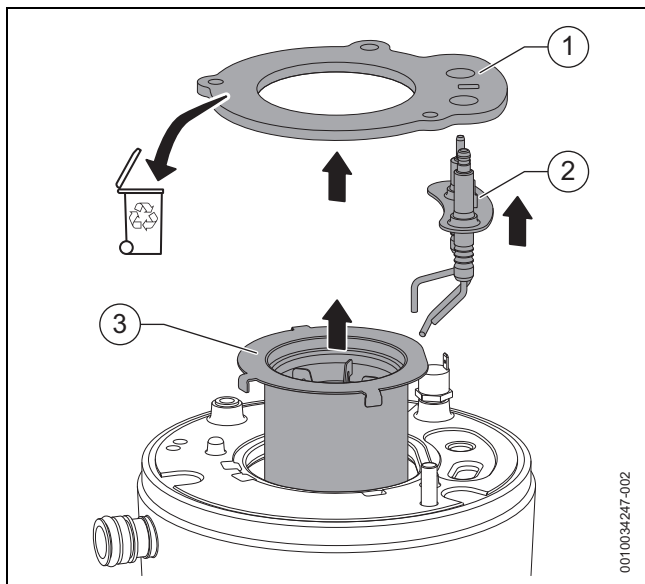

Fig. 78 Removing the burner

Refer to figure 79.

- ▶ Remove the top baffle using the lifting device.
- ▶ Remove the bottom baffle using the lifting device.

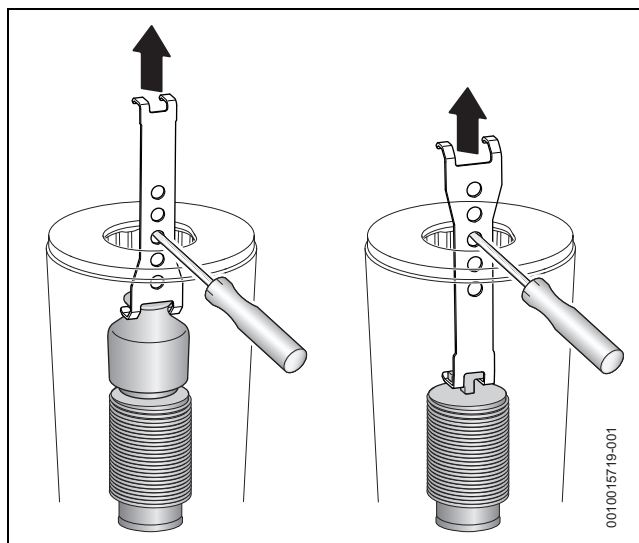

Fig. 79 Remove the top and bottom baffles

- ▶ Check for damage or deformation and then clean both baffles.

Refer to figure 80.



To gain better access from above, remove inspection aperture from the top panel of the appliance.

- ▶ Clean the heating exchanger with the brush:
 - by rotating in both directions
 - from top to bottom
- ▶ Remove the screws from the inspection aperture cover and remove with the seal.

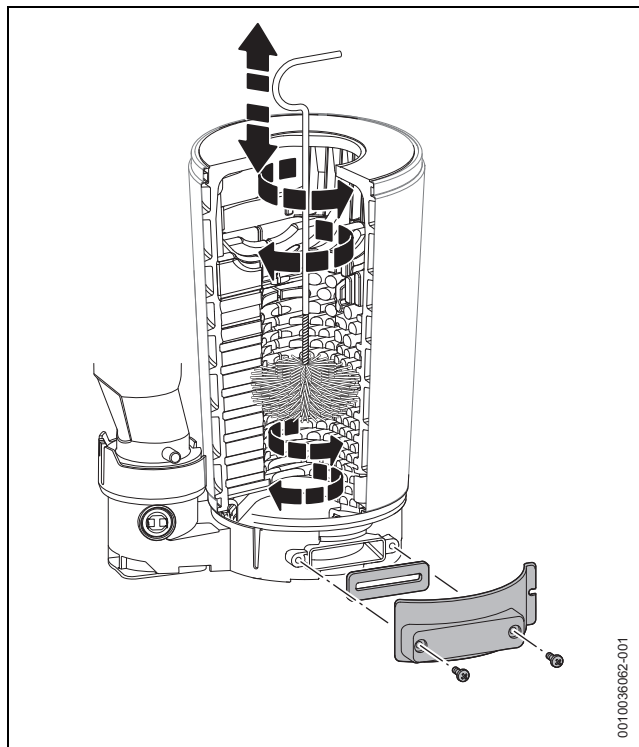

Fig. 80 Cleaning the heat exchanger

- ▶ Clean out residue and re-fit the inspection aperture again.

Refer to figure 81.

- ▶ Rinse the heat exchanger with water from the top.

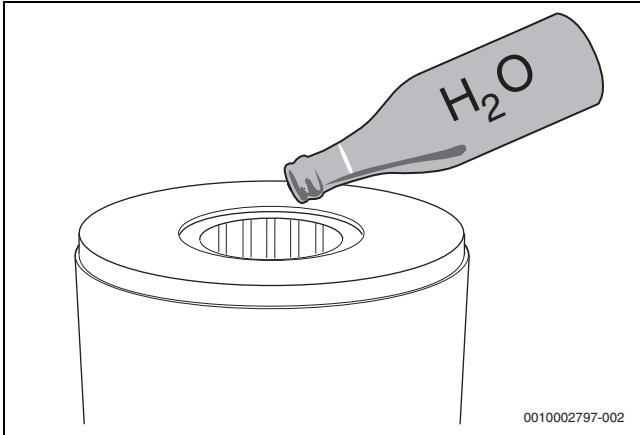

Fig. 81 Rinse the heat exchanger with water

Refer to figure 82.

- ▶ Re-open inspection aperture and ensure no residue remains.
 - Close the inspection aperture once checked.

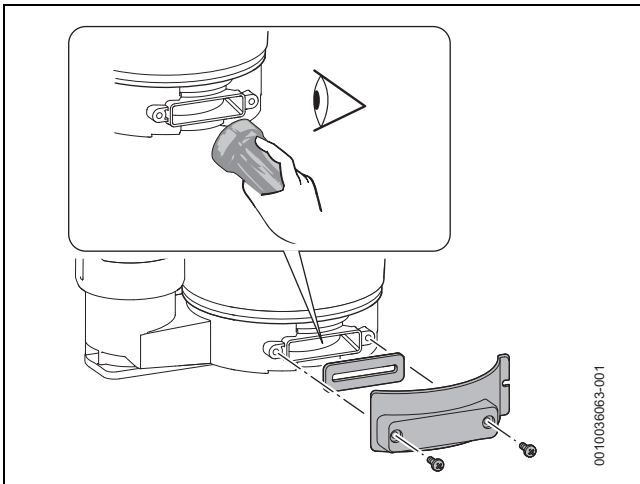

Fig. 82 Checking the heat exchanger for residue

- ▶ Refit the cleaned baffles.
- ▶ Clean the condensate trap before carrying out the following checks (→ section 78).
- ▶ Check that pathways are clear by carrying out Checking heat exchanger assembly. (→ section 9.5.1).
- ▶ Check and adjust if required the gas/air ratio.



On completion of the heat exchanger cleaning and reassembly, perform the fan pressure test.

9.9.2 Cleaning the siphon

Cleaning the condensate trap



WARNING

Danger to life due to poisoning!

If the condensate trap is not filled, poisonous flue gas can escape.

- ▶ Ensure the trap is filled prior to replacing it.
- ▶ Make sure that the condensate drains off properly.



Clean the condensate trap regularly.

1. Unlock the condensate trap.
2. Detach the hose from the condensate trap.
3. Tilt the condensate trap to the right for draining.

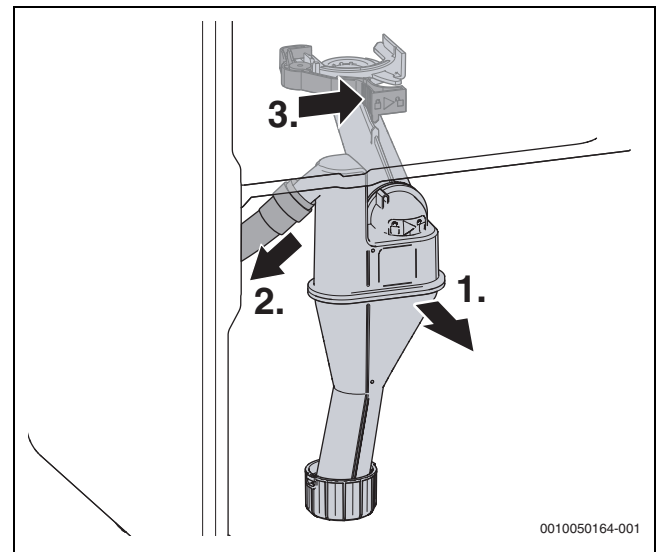

Fig. 83 Removing the condensate trap

- ▶ Clean the condensate trap.
- ▶ Remove and clean dirt trap at the bottom.
- ▶ Dispose of the old gasket (47.22 × 3.53).
- ▶ Install new gasket.
- ▶ Reinsert the dirt trap and check for tightness.

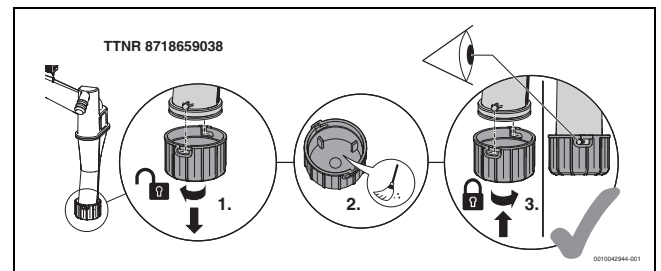

Fig. 84 Clean dirt trap

- ▶ Check the aperture towards the heat exchanger.
- ▶ Remove the gasket on the top of the condensate trap.
- ▶ Check the gasket for cracks, deformation or breakage, and replace if necessary.

- ▶ Inserting the gasket on the condensate trap.

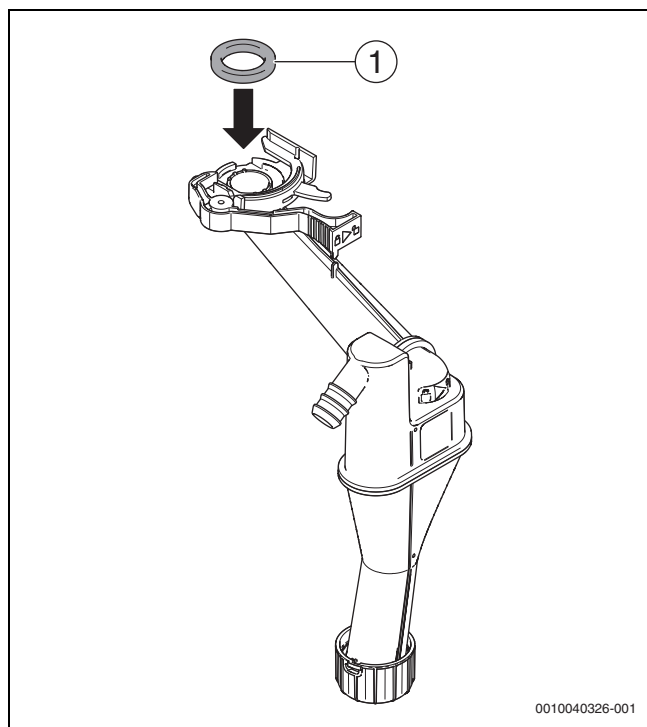

Fig. 85 Inserting the gasket on the condensate trap

- ▶ Grease the gasket.
- ▶ Check the condensate hose and clean if required.
- ▶ Fill the condensate trap with approx. 250 ml water.
- ▶ Insert the condensate trap and ensure gasket is seated correctly.

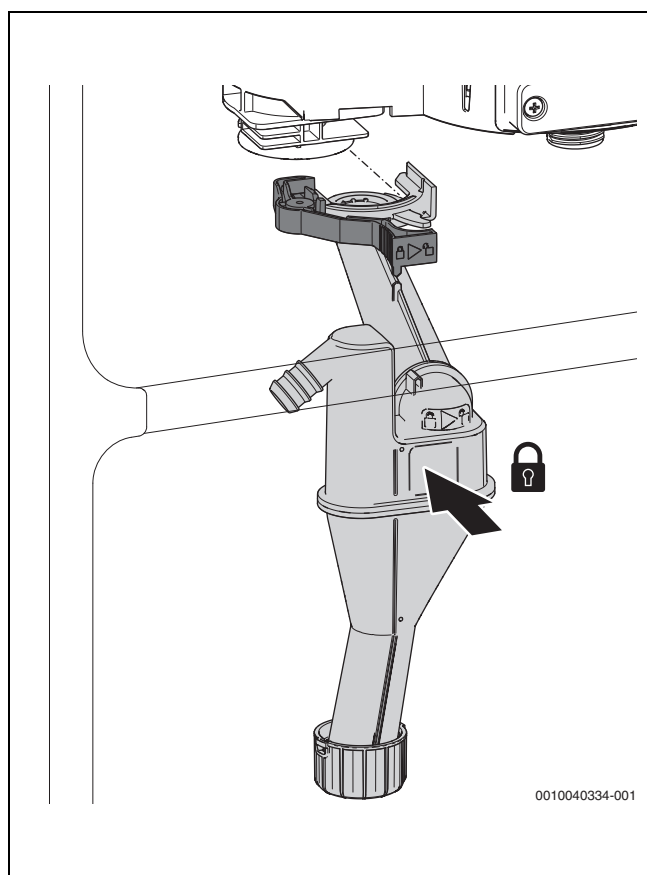

Fig. 86 Inserting the condensate trap

9.10 Setting the air/gas ratio

NOTICE

Setting the air/gas ratio

- ▶ The air/gas ratio is factory set and should not need to be adjusted. If found to be out of tolerance and when all other possible causes have been checked, please contact the Worcester Bosch Group helpline 0330 123 3366.

NOTICE

Combustion testing

- ▶ The checking of the air/gas ratio **must** be carried out by a competent registered gas engineer, such as a Gas Safe registered engineer or British Gas engineer.
- ▶ Checking of the air/gas ratio **must not** be attempted unless the person carrying out the test is equipped with a flue gas analyser conforming to BS7927 and is competent in its use.



All CO/CO₂ readings must be taken with the combustion chamber cover ON.

Adjustments can only be made with the cover off.



CO₂ should be measured 10 minutes after firing the appliance.

Adjusting the minimum rated output settings

With the appliance in minimum rated output.

- ▶ Remove the seal from the adjusting screw of the gas valve (only gas valve is shown in the below Figure 87) and set the CO₂ content for minimum rated output.

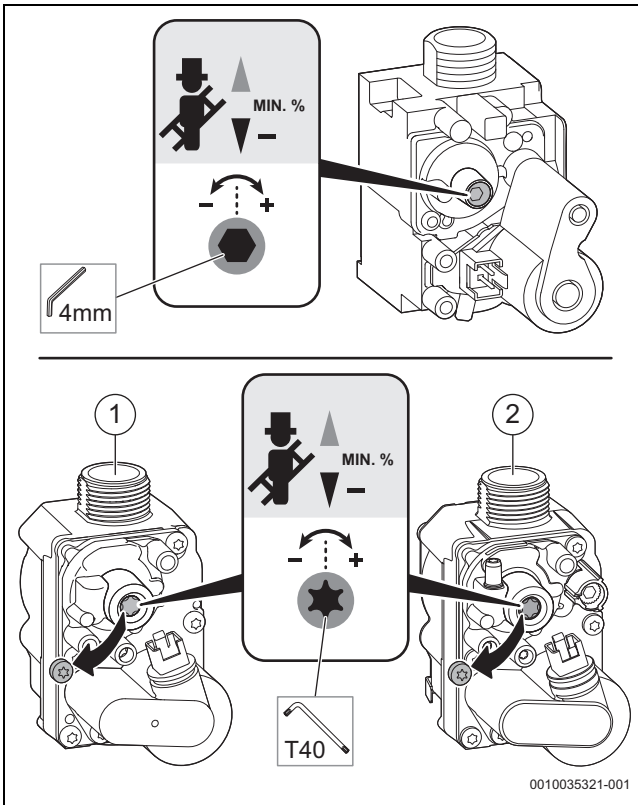

Fig. 87 Setting the CO₂ content (above: SIT valve, below Honeywell valves)

- [1] Gas valve - NG
- [2] Gas valve - LPG

- ▶ Re-check settings at maximum and minimum rated output and re-adjust if required.
- ▶ Seal the gas valve minimum adjustment.
- ▶ Exit the chimney sweep mode.
- ▶ Enter the CO₂ contents in the servicing record.

Adjusting the maximum rated output settings (LPG appliances)

With the appliance in maximum rated output.

- ▶ Insert the hex tool into the adjusting screw of the gas valve (as shown in the below Figure 88) and set the CO₂ content for maximum rated output.

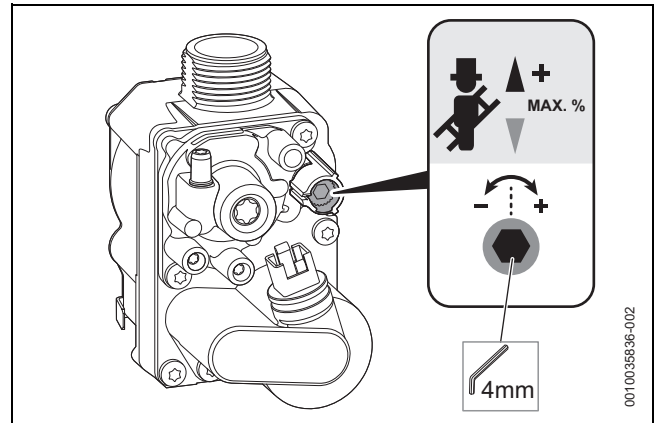

Fig. 88 Setting the CO₂ content

- ▶ Re-check settings at minimum and maximum rated output and re-adjust if required.
- ▶ Exit the chimney sweep mode.
- ▶ Enter the CO₂ contents in the servicing record.

10 Replacement parts



WARNING

Mains supplies - Isolate the appliance

- ▶ Turn off the gas supply and isolate the mains electrical supply before starting any work and observe all relevant safety precautions.
- ▶ Drain the appliance/system where necessary and protect any electrical equipment from water ingress during component replacement.



WARNING

Component replacement:

- ▶ After replacement of a gas carrying component, where a gasket or seal has been disturbed or replaced, check for gas tightness using a gas sniffer/leak detection fluid.
- ▶ On re-assembly check all affected seals for cracks, hardness and deterioration.
 - If damaged or in any doubt the seal must be replaced.
- ▶ Also after re-assembly, carry out the following checks:
 - Fan pressure.
 - Flue gas analysis.



Only use Worcester, Bosch Group original spare parts with this appliance. Non Worcester, Bosch Group original spare parts will invalidate the guarantee (if applicable) and any warranty.

- ▶ A comprehensive list of appliance spares can be found on the website www.worcester-bosch.co.uk/spares

10.1 Component access

Removing the front casing



The front casing is secured with two screws which are critical to maintain the case seal and to prevent unauthorised removal (electrical safety).

- ▶ Always secure the casing with these screws.
- ▶ Loosen the two screws [1] and pull the bottom of the casing forward.
- ▶ Lift off the casing.

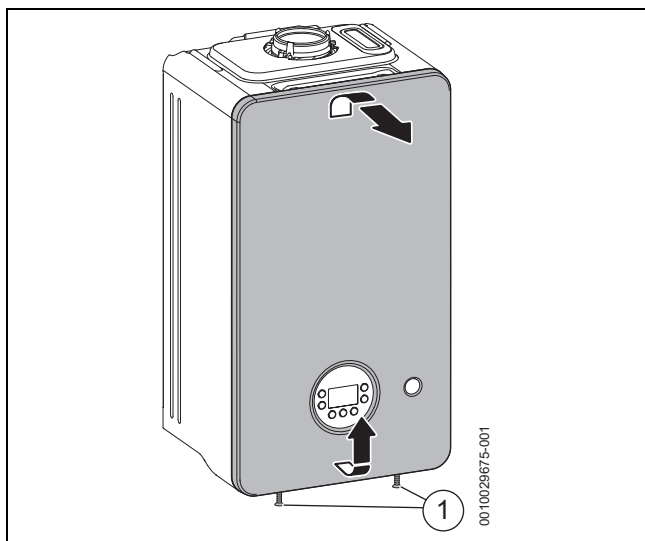

Fig. 89 Removing the front casing

10.2 Draining the appliance



CAUTION

Risk of scalding!

- ▶ Take care when draining down, hot residual water can represent a potential scalding risk

NOTICE

Risk of water damage to appliance or property!

Damage from disconnecting water pathways which may have retained some water.

- ▶ Take care after draining the appliance to protect equipment/property from residual water content within components.

Many of the tasks in this section require that the appliance be isolated and drained. This will be indicated in the manual if required.

Refer to figure 90.

- ▶ Use drain lever for opening and closing the drain outlet by turning.

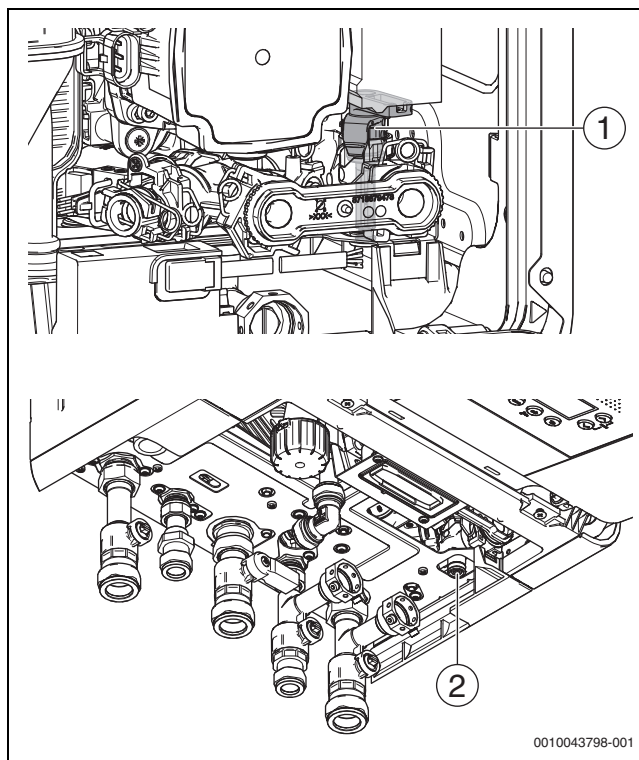

Fig. 90 Drain point

- [1] Drain lever
- [2] Drain outlet

10.3 Checking the strainer in the cold water pipe

NOTICE

Risk of damage to plastic thread

Re-connection of pipe connection union nut.

- ▶ Do not over-tighten the nut due to risk of stripping the thread.

1. Undo the nut.
2. Remove the pipe.
3. Remove the clip.
4. Pull out the pressure relief valve.

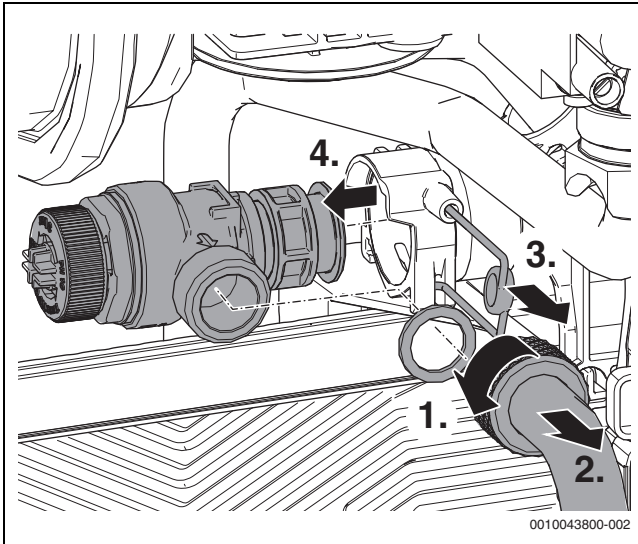

Fig. 91 Remove the pressure relief valve (heating circuit)

1. Remove the clip.
2. Pull out the insert.
3. Check strainer for contamination.

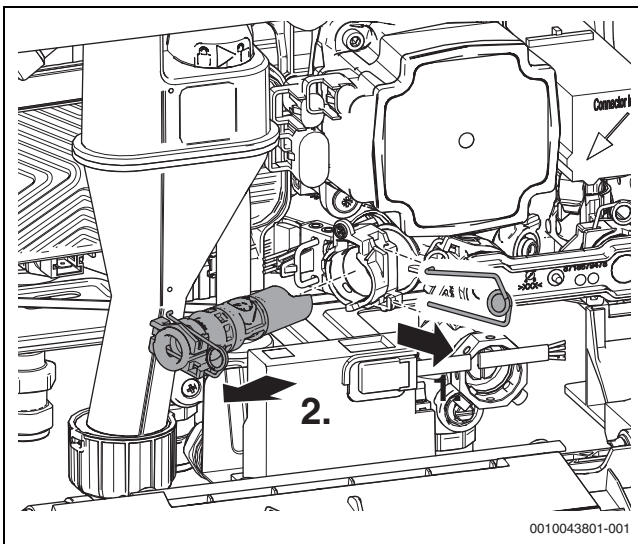

Fig. 92 Checking the strainer in the cold water pipe

10.4 Checking the flow turbine

Removing the flow turbine

- ▶ Close the DCW valve [1] and CH valve [2].

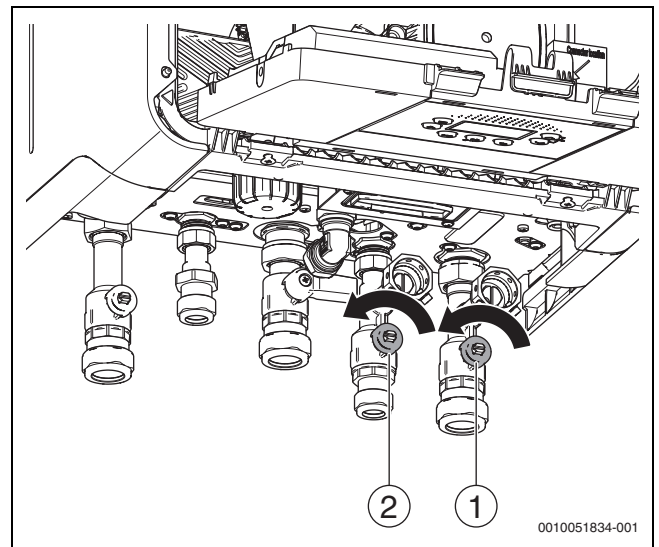

Fig. 93

- ▶ Drain remaining water by using the drain valve [1].

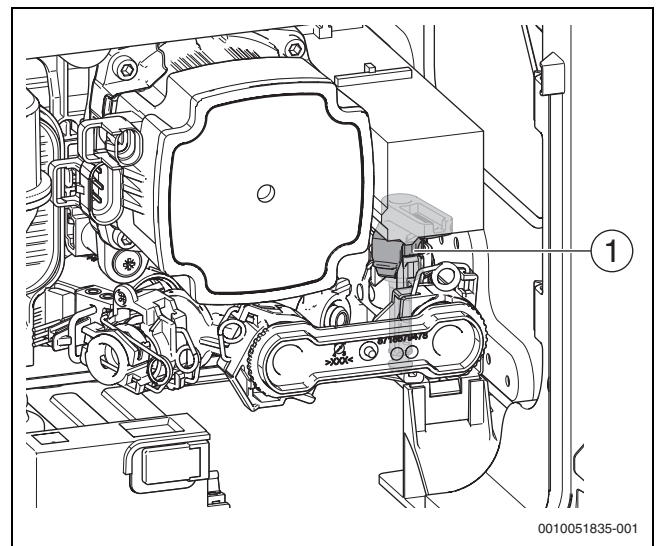

Fig. 94

- ▶ Remove the clips [1] and the plug [2].

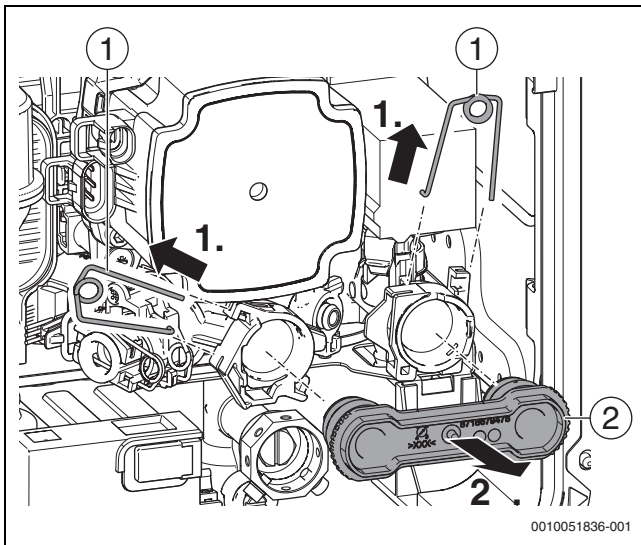

Fig. 95

- ▶ Remove the clip [1] and the cable [2] of the flow turbine.

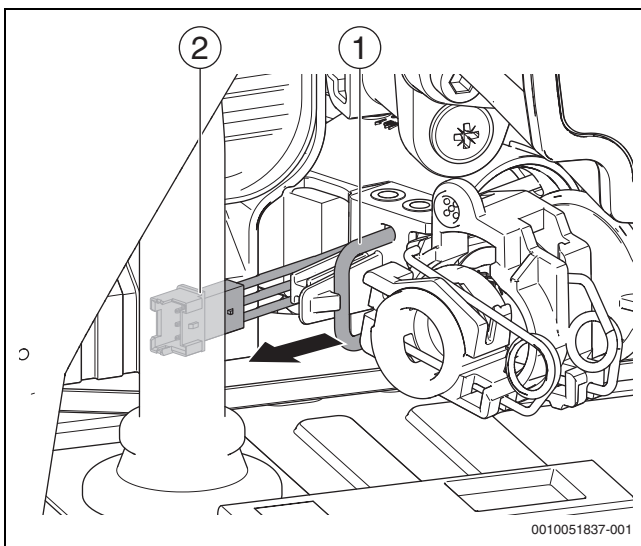

Fig. 96

- ▶ Remove the complete DCW housing [1] from the hydraulics.

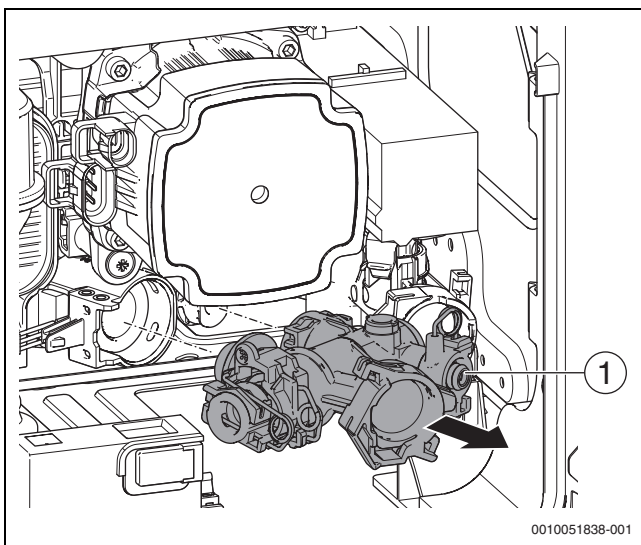

Fig. 97

- ▶ Remove the turbine using a screwdriver.

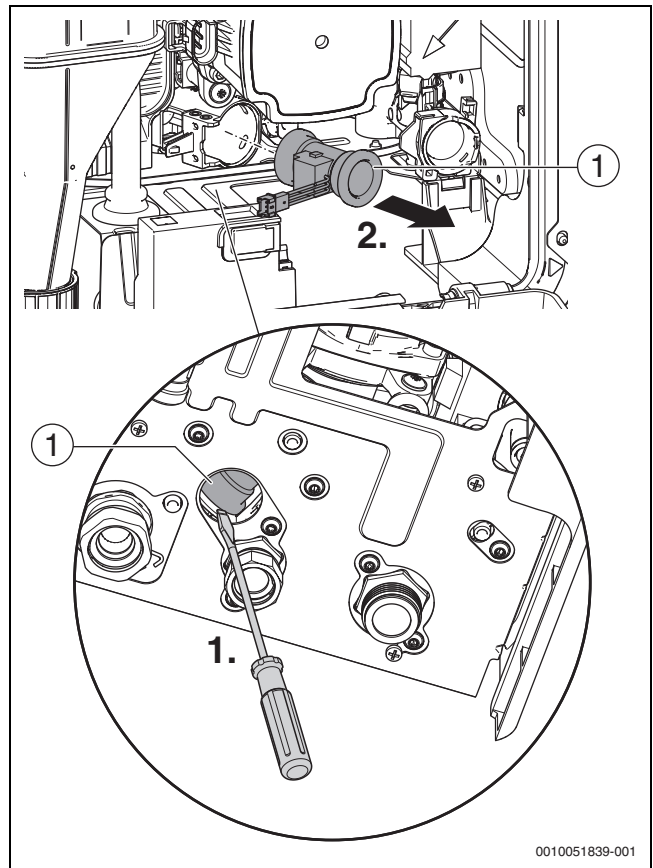

Fig. 98

- ▶ Remove the o-ring gasket [1] using the gasket tool included with the flow turbine spare parts [2].

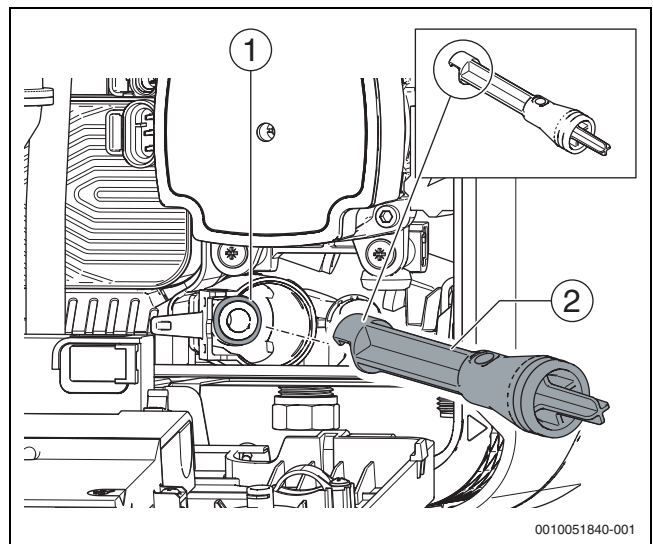

Fig. 99

Assembling the flow turbine

- ▶ Clip on the o-ring gasket [1] using the gasket tool [2] and a screwdriver [3].

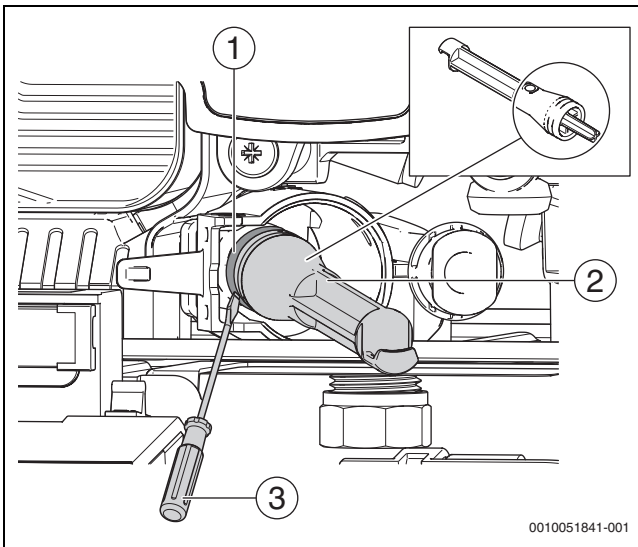

Fig. 100

- ▶ Insert the flow turbine cable into the housing [1] and assembly the flow turbine [2].

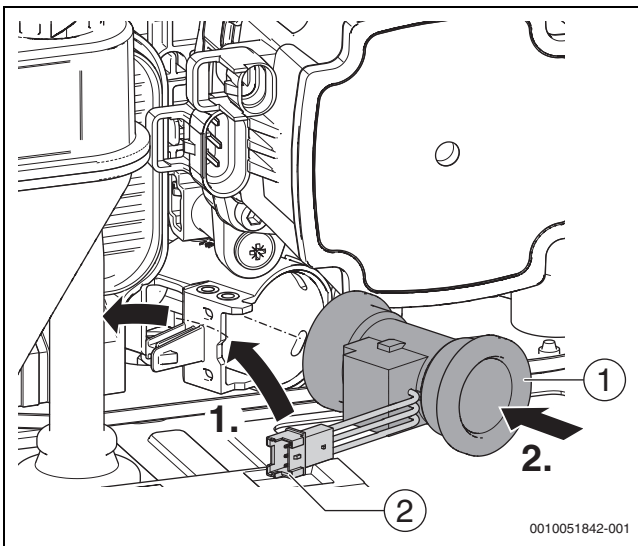

Fig. 101

- ▶ Assembly the flow turbine in reverse order.

10.5 Checking the plate heat exchanger

If the DHW output is insufficient:

- ▶ Check the strainer in the cold water pipe for contamination.
- ▶ Remove the plate heat exchanger and replace if necessary.

1. Remove the screw.
2. Remove the plate heat exchanger.

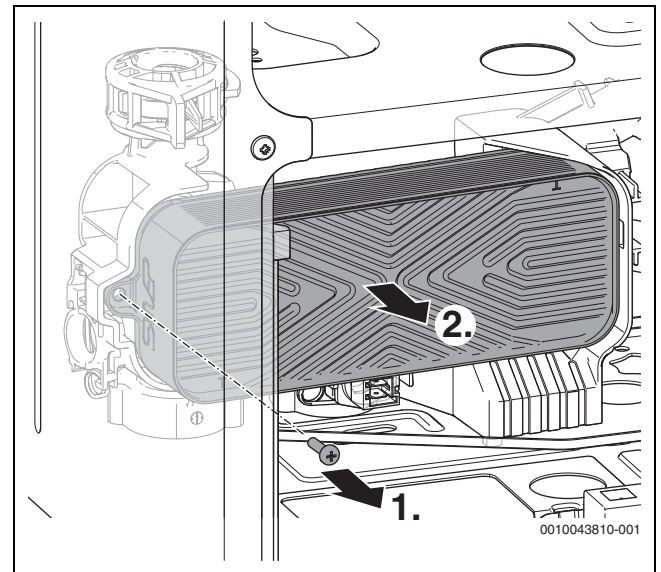

Fig. 102 Removing the plate heat exchanger

10.6 Checking the expansion vessel

The expansion vessel must be checked every year.

- ▶ If necessary, adjust the expansion vessel pre-charge pressure to the static head of the heating system.

10.7 Adjusting the operating pressure of the heating system

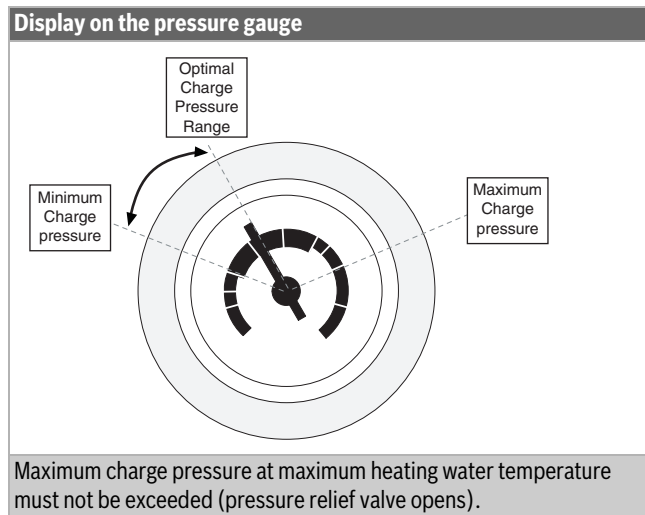

Table 37

If the indicator is below 1 bar when the system is cold:

- ▶ Top up the water until the indicator is between 1 bar and 1.5 bar again.

If pressure is not being maintained:

- ▶ Check tightness of expansion vessel and heating system.

Operating pressure checking of the heating system via HMI



	Displayed when system pressure is lower than 1.1 bar.
	Displayed when system pressure is higher than 1.3 bar. ▶ Stop filling the system and press the ok key.

Table 38

10.8 Removing the gas valve

- ▶ Close gas isolator.
- ▶ Unplug the plug [1].
- ▶ Undo the union nut on the top of the gas valve [2].
- ▶ Pull off the gas hose and pressure reducer [3].
- ▶ Undo the union nut [4] on the bottom of the gas valve.

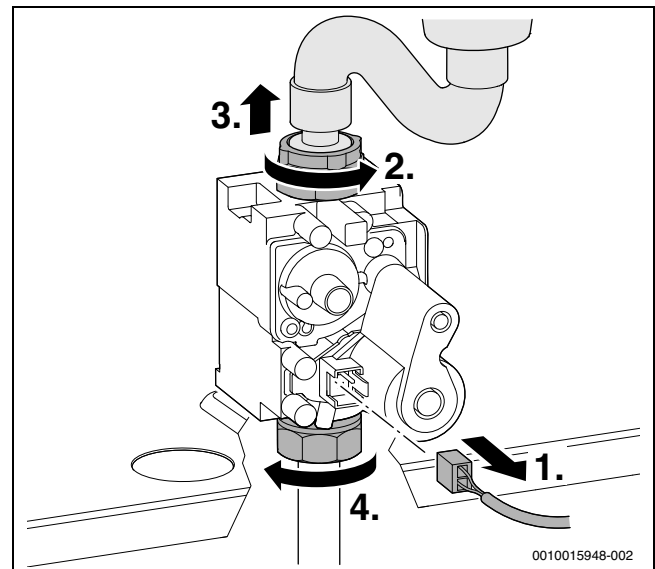

Fig. 103 Pull off the plug and undo the union nuts

- ▶ Remove 2 screws and take off gas valve.

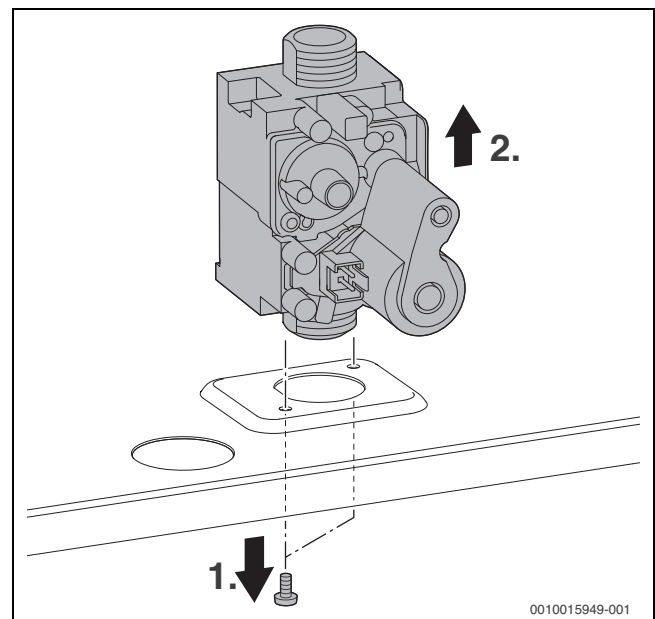

Fig. 104 Removing the gas valve

- ▶ Install the gas valve in reverse order, and check the gas/air ratio.

10.9 Removing the pump

- ▶ Unplug the electrical connections [1].
- ▶ Release the ratchet connection [2] between pump and heat exchanger assembly.
- ▶ Loosen the securing screws [3].
- ▶ Remove pump assembly [4].

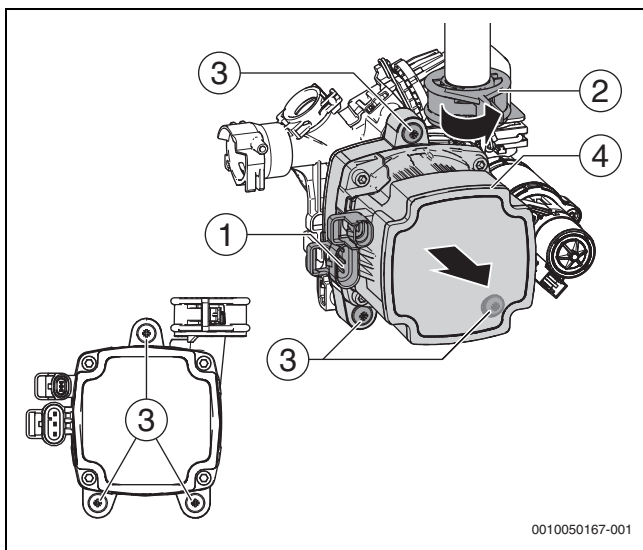

Fig. 105 Removing the pump

- ▶ Install the pump in reverse order.

10.10 Removing the automatic air vent valve

1. Remove the clip [1].
2. Pull out the automatic air vent valve.

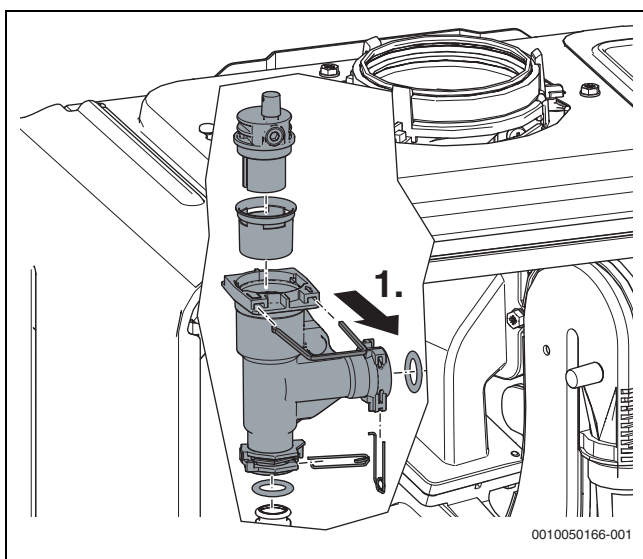

Fig. 106 Removing the automatic air vent valve

10.11 Checking/replacing the motor of the 3-way valve

The appliance is manufactured with two 3-way valve variants. They are identified by the motor secured via a locking clip or by screws.

- ▶ Detach the motor in the sequence shown.
 - Disconnect the plug [1].
 - Remove the screws [2].
 - Pull on the motor gently and lift it up [3].
 - Remove the motor [4].

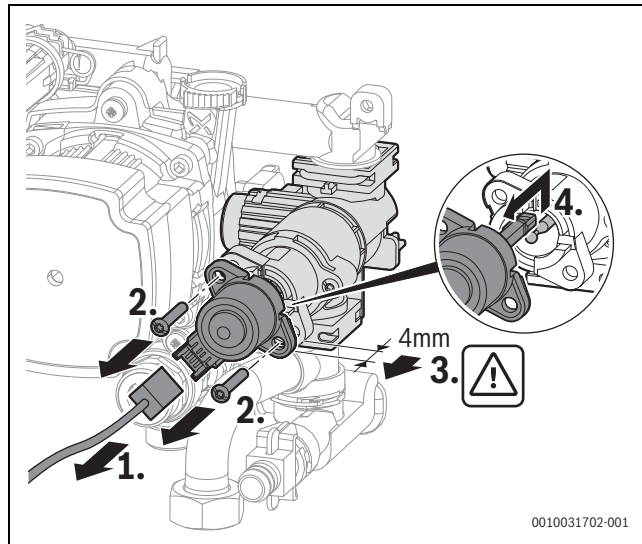

Fig. 107 Detaching the motor from the 3-way valve

Installing the motor.



When suspending the motor, do not push against the ball head, as it will be hard to pull it out again.

- ▶ Install the motor in the sequence shown.
 - Insert the motor and align above the ball head. Push down to engage [1].
 - Pull gently on the motor to ensure it has properly engaged onto the ball [2].
 - Push the motor in and fasten it in place using 2 screws [3].
 - Connect the plug [4].

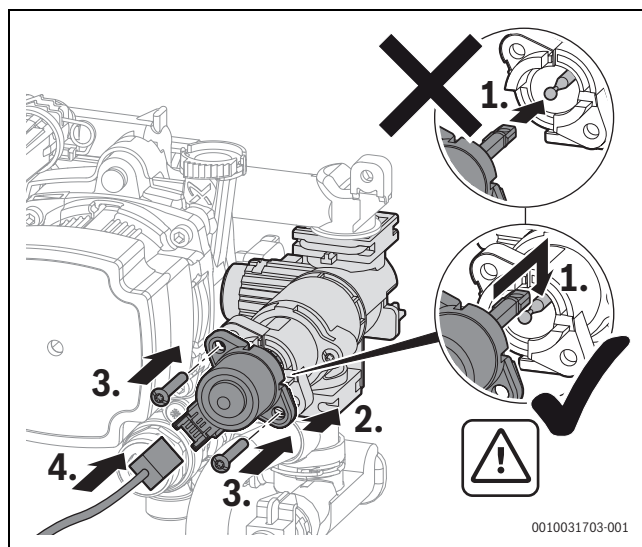

Fig. 108 Installing the motor in the 3-way valve

10.12 Removing the heat exchanger assembly

- ▶ Remove the fan, gas hose, mixing device and burner cover as described in Chapter "Checking the electrodes and cleaning the heat exchanger", page 65.

Separating components from the heat exchanger assembly.

Refer to figure 109.

- ▶ Separate components from the heat exchanger assembly in the sequence shown.
 - Release the clip [1].
 - Detach the flow connection [2].
 - Disconnect the cable from the heat exchanger temperature limiter [3].
 - Disconnect the flow temperature sensor on the heat exchanger [4].
 - Disconnect the cable from the flue gas temperature limiter [5].
 - Remove the nut [6].

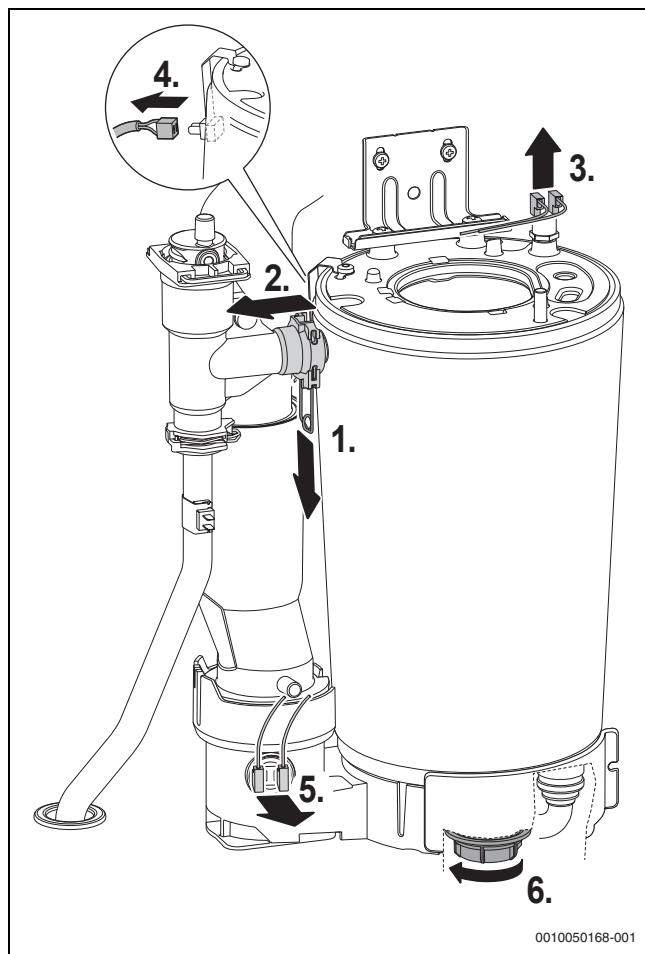

Fig. 109 Separating components from the heat exchanger assembly

Removing the heat exchanger assembly

Refer to figure 110.

- ▶ Release the flue pipe clip [1].
- ▶ Push the flue pipe up [2].
- ▶ Remove the bracket screws [3].

- ▶ Remove the heat exchanger assembly [4].

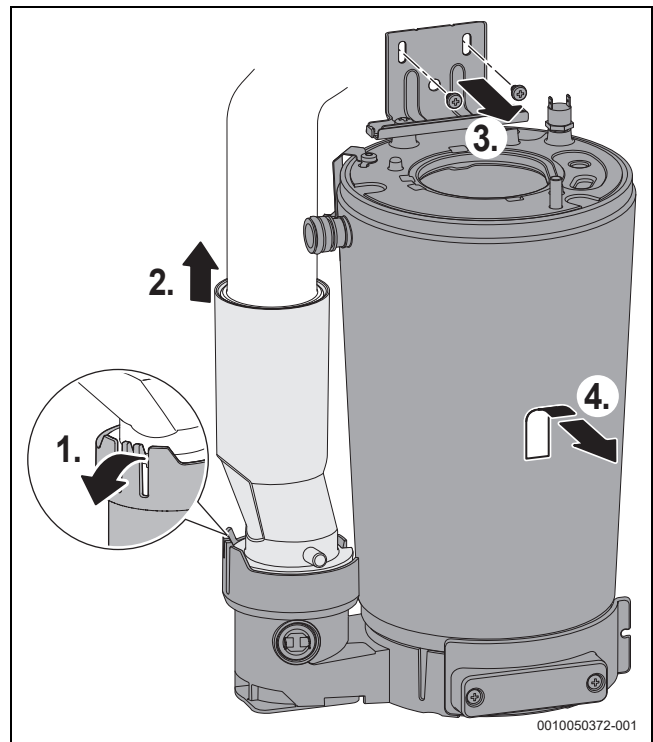

Fig. 110 Removing the heat exchanger assembly

10.13 Replacing the control unit



The devices are delivered without code plug.

- ▶ When replacing the control unit, ensure the code plug supplied is used.
- ▶ Flip the electronics panel down (→Fig. 5.5.1 page 43).
- ▶ Replace the control unit [1].

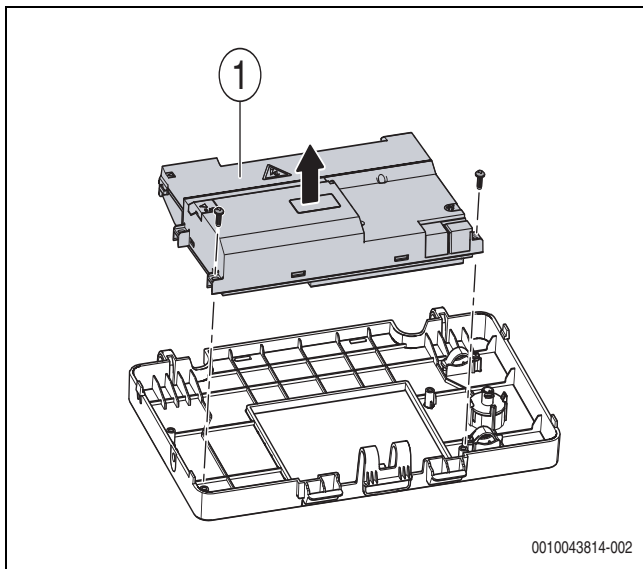

Fig. 111 Replacing the control unit

- ▶ Open the cover [1] on the enclosure of the appliance electronics.
- ▶ Insert the code plug supplied [2].

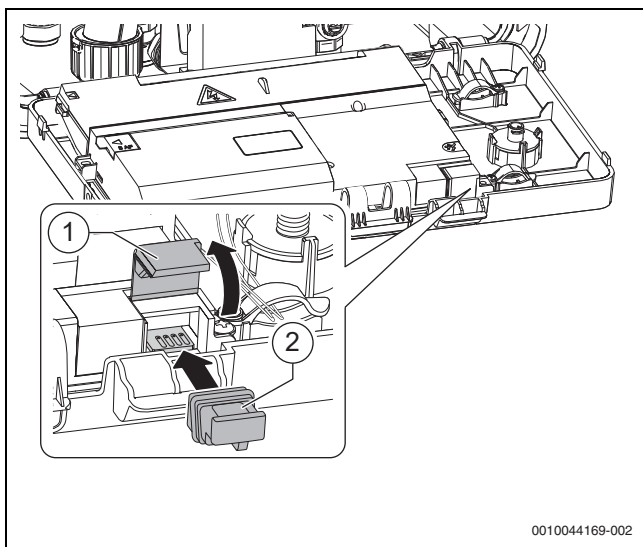

Fig. 112 Inserting the code plug

10.14 Reattaching the casing on the side

- ▶ Align the side panel so that the underside can be guided along the flange.
- ▶ Push the side panel towards the rear [1].
- ▶ Tighten the fixing screws [2].

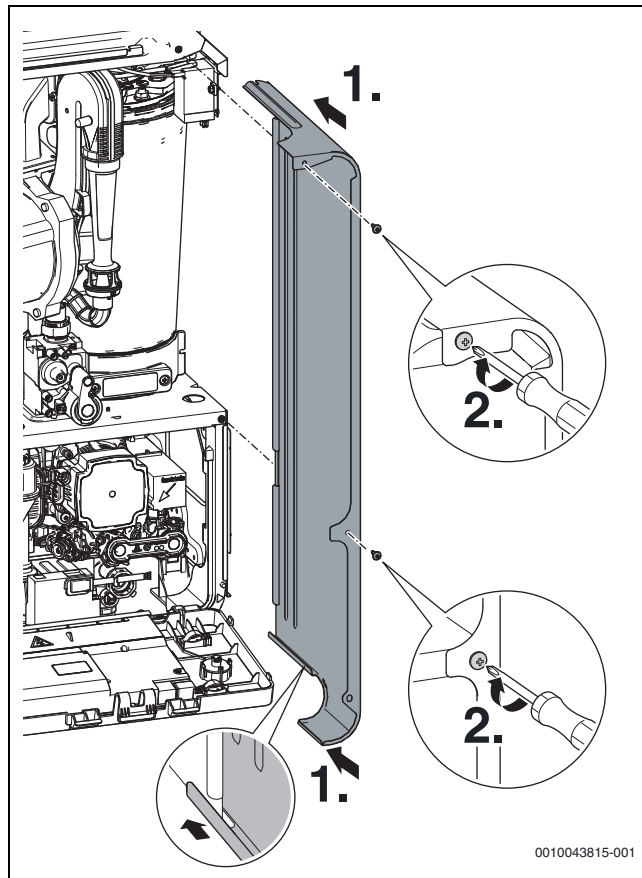

Fig. 113 Attaching the side panel

10.15 Replacing the expansion vessel

- ▶ Disconnect the pipe union nut [3].
- ▶ Slacken the screws on the clamps, top [1] and bottom [2] of the expansion vessel.
- ▶ Slide the expansion vessel [4] towards you to remove.

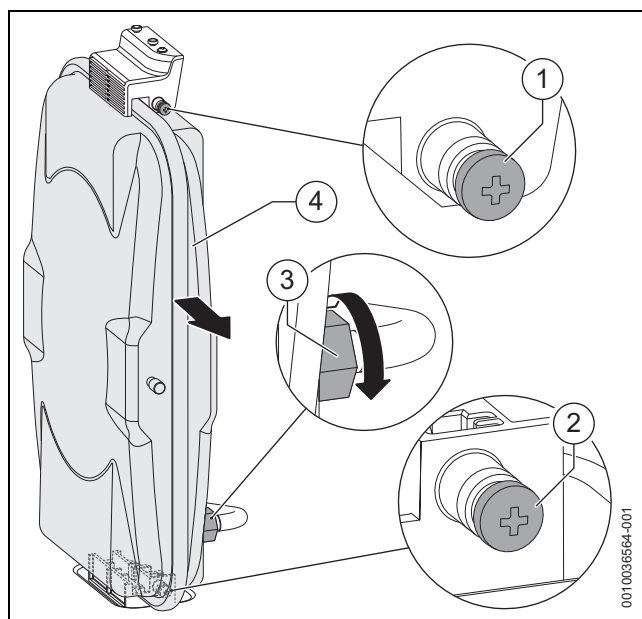

Fig. 114

- ▶ Replace the expansion vessel in the reverse order

11 Fault finding and diagnosis



This fault finding information is for guidance only. Worcester cannot be held responsible for costs incurred by persons not deemed to be competent.



This fault finding system assumes that the appliance has been operating normally until the time of failure (i.e. not a first time installation error).

Basic checks

- Ensure that there is 230V power supply and the polarity is correct to the appliance.
- Ensure that the appliance settings and functionality is correct.
- Ensure the CH/DHW programmer/timer is functioning.
- Ensure the room thermostat is functioning.
- Ensure the cylinder thermostat (if fitted) is functioning.
- Ensure the cold water mains is turned on.
- Ensure the primary system has adequate pressure/system content for the system type.
- Ensure there is gas to the appliance.
 - Are other gas appliances working, gas cooker/hob for example?
 - Has the credit run out on the gas pre-payment meter?

NOTICE

On completion of the Service/Fault-Finding task which has required the breaking and remaking of electrical connections, check:

- ▶ Earth continuity,
- ▶ Short circuit check,
- ▶ Polarity,
- ▶ Resistance to earth.

11.1 General information

Indicators (fault category O)

Indicators signal operating conditions during normal operation. Indicators can be read out with the service function 1-A1.

Non-blocking faults (fault category R)

The heating system remains in operation with non-blocking faults. The symbol is shown on the display.

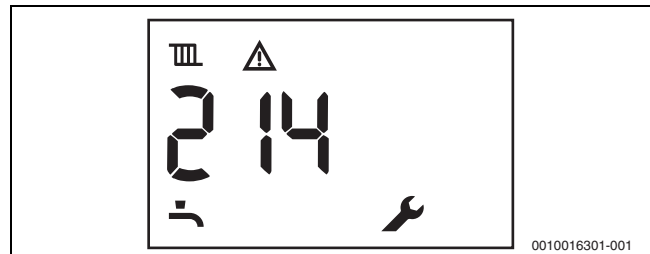

Fig. 115 Example: non-blocking fault

Resetting a non-blocking fault

- ▶ Press the key until the and symbols are displayed. The fault code with the smallest number is displayed.
- ▶ To select a fault code: press arrow key or .
- ▶ To delete the fault code: press the **OK** key.
- ▶ Follow the same procedure to delete further fault codes.

Blocking faults (fault category B)

Blocking faults result in the heating system being shut down temporarily. The heating system restarts automatically as soon as the blocking fault is removed.

If the blocking fault persists for a prolonged period, it becomes a locking fault.

The fault code of a blocking fault can be read out with the service function 1-A2.

Locking faults (fault category V)

Locking faults result in the heating system being shut down, and the system can only be restarted after a reset.

The fault code of a locking fault flashes together with the on the display.

- ▶ Turn the power to the boiler off and on again.

-or-

- ▶ Press the arrow keys and at the same time until the symbols and disappear. The device resumes operation. The flow temperature is displayed.

If a fault persists:

- ▶ Check PCB, replace if required.
- ▶ Adjust the service functions as directed on the “Settings in the service menu” label.

Blocking into Locking faults (B/V)

If the blocking fault persists for a prolonged period, it becomes a locking fault.

Fault category W (maintenance codes)

11.2 Fault code table

Fault code	Fault category	Description	Remedy
200	O	Boiler in heating mode	Operating message, is not a fault.
201	O	Boiler in hot water mode	Operating message, is not a fault.
202	O	Boiler in anti-cycle mode	Operating message, is not a fault.
203	O	Boiler in standby, no heat energy demand	Operating message, is not a fault.
204	O	Current prim. water temp. higher than set val.	The actual boiler water temperature is higher than the target boiler water temperature. The boiler is switched off.
208	O	Chimney sweep demand	Operating message, is not a fault.
212	-	Rise in temp. of safety or heating flow sensor too fast	Open the shut-off valves.
214	V	Fan shut down during safety time	<ul style="list-style-type: none"> ▶ Reset the appliance. ▶ Create a heat demand; check if the boiler fires up. ▶ Check the voltage to the fan and the continuity of the fan harness. ▶ Check the power modulation on the fan. ▶ PCB may be defective.
215	V	Fan shut down during safety time	<ul style="list-style-type: none"> ▶ Replace fan. ▶ Mains voltage must correspond to the default value. ▶ Check PCB and fan harness, replace if necessary.
224	B/V	Safety temp. limiter has tripped	<ul style="list-style-type: none"> ▶ Check if lead is disconnected from the safety temperature limiter. ▶ Check the high limit of the safety temperature limiter and the harness for continuity. ▶ Check the flow temperature to confirm actual temperature (may have tripped out at lower temperature, leading to safety temperature limiter fault). ▶ Check the system pressure and top up as required. ▶ Check if air is trapped in the system and in the boiler. ▶ Pump seized/not running: check the pump for failure or blockage. ▶ Check if blockage/restriction within boiler/pipe work restricting the flow.
227	B/V	No flame signal after ignition	<p>Tip: Check the ceramic insulator is not damaged, this can cause the spark to earth, twist and pull the ceramic insulator to ensure it is not broken.</p> <ul style="list-style-type: none"> ▶ Check the gas supply to property and the inlet on the gas valve. ▶ Check the low pressure when the gas valve opens. ▶ Gas valve failing to open: check for voltage to the valve and for possible blockage on inlet filter of the gas valve. ▶ Obstruction in the air intake to the fan leading to incorrect CO₂ ratio. Diaphragm is damaged or stuck. ▶ Condensate trap is blocked or restricted. Condensate pipe is frozen. ▶ Flue is blocked or restricted. ▶ Heat exchanger is blocked or restricted. ▶ Check the burner for damage. ▶ Check the spark electrode or the lead failure. ▶ Check the flame sense or the lead failure. ▶ Check the rectification ground (black wire to heat exchanger).
228	V	Flame signal without flame present	<p>Tip: Check the ceramic insulator is not damaged, this can cause the spark to earth, twist and pull the ceramic insulator to ensure it is not broken.</p> <ul style="list-style-type: none"> ▶ Check the flame sense and the lead and replace if required. ▶ Check the earth tags on the boiler and on the electrodes. ▶ Check the operation of the siphon and no water collecting in the sump. ▶ Replace the air and/or gas ratio control valve. ▶ Replace the control unit and/or burner control unit.
229	B	Flame failed during burner operation	<p>Tip: Check the ceramic insulator is not damaged, this can cause the spark to earth, twist and pull the ceramic insulator to ensure it is not broken.</p> <ul style="list-style-type: none"> ▶ Check the gas supply to the property and check the working pressure on the gas valve inlet. ▶ Check the gas-air ratio. ▶ Check the ionisation electrode and the harness for damage or contamination. ▶ LPG: Sufficient gas in the tank or recently refilled?

Fault code	Fault category	Description	Remedy
232	B	Boiler locked by external switching contact	<p>External cut off switch not used in UK: Ensure nothing is plugged into red I3 connection.</p> <ul style="list-style-type: none"> ▶ Connection plug for external switch contact is not plugged into PCB. ▶ There is no feedback voltage at the external safety contact of a third party condensate pump blocking the boiler. ▶ Switching point for the external temperature monitor is set too low. ▶ Connection cable to the external temperature monitor is damaged. ▶ External temperature monitor is defective.
233	V	Boiler identification module or device electronics faulty	<p>If code plug is present:</p> <ul style="list-style-type: none"> ▶ Check that correct plug is inserted. ▶ Check the code plug is not damaged. ▶ Replace the code plug if required. <p>If code plug is not present:</p> <ul style="list-style-type: none"> ▶ Check appliance electronics (PCB), replace if necessary.
234	V	Gas valve electrical fault	<ul style="list-style-type: none"> ▶ Check the gas supply to the property and the inlet on the gas valve (check drop on inlet). ▶ Check the connections on the gas valve and the board (loose connection). ▶ Check the continuity down harness and replace if required. ▶ Check the voltage to the gas valve (19–24 V DC approx. when demand). ▶ Check for water on the gas valve connections. ▶ Check the resistance on the gas valve (pins 1–2 approx. 69.5 Ohms). ▶ Replace the gas valve if resistances are incorrect. ▶ If all tests are correct: replace the PCB.
235	V	Conflicting versions of boiler electr. and boiler identification	<p>If code plug is present:</p> <ul style="list-style-type: none"> ▶ Check that correct plug is inserted. ▶ Check the code plug is not damaged. ▶ Check the code plug software version. ▶ Replace the code plug if required. <p>If code plug is not present:</p> <ul style="list-style-type: none"> ▶ Check appliance electronics software version, replace if necessary.
237	V	System fault	<p>If code plug is present:</p> <ul style="list-style-type: none"> ▶ Check that correct plug is inserted. ▶ Check the code plug is not damaged. ▶ Replace the code plug if required. <p>If code plug is not present:</p> <ul style="list-style-type: none"> ▶ Check appliance electronics (PCB), replace if necessary.
238	V	Boiler electronics faulty	<ul style="list-style-type: none"> ▶ Check the gas supply to the property and the inlet on the gas valve (check drop on inlet). ▶ Check the connections on the gas valve and the board (loose connection). ▶ Check the continuity down harness and replace if required. ▶ Check the voltage to the gas valve (19–24 V DC approx. when demand). ▶ Check for water on the gas valve connections. ▶ Check the resistance on the gas valve (pins 1–2 approx. 69.5 Ohms). ▶ If all tests are correct: replace the PCB.
242	V	Boiler electr. system fault	<ul style="list-style-type: none"> ▶ Reset control appliance / burner control unit - factory reset. ▶ Reconnect electrical connections at control unit / burner control unit correctly. ▶ Replace the control unit/burner control unit.
244	V	System fault boiler electronics / basic controller	<ul style="list-style-type: none"> ▶ Reset control appliance / burner control unit - factory reset. ▶ Reconnect electrical connections at control unit / burner control unit correctly. ▶ Replace the control unit/burner control unit.
245	V	State out of range	<ul style="list-style-type: none"> ▶ Restart the appliance to see if the problem re-occurs. ▶ Check the electrical connections on the board (check for loose wires etc.). ▶ Check the code plug, if present, is not damaged. ▶ Replace the code plug, if present and required. ▶ Replace the control unit (PCB).
246	-	System fault boiler electronics / basic controller	<ul style="list-style-type: none"> ▶ Reset burner control - factory reset. ▶ Check electrical connections of burner control. ▶ Replace burner control.

Fault code	Fault category	Description	Remedy
247	-	System fault boiler electronics / basic controller	<ul style="list-style-type: none"> ▶ Reset burner control - factory reset. ▶ Check electrical connections of burner control. ▶ Replace burner control.
249	V	Internal software error	<ul style="list-style-type: none"> ▶ Restart the appliance to see if the problem re-occurs. ▶ Check the electrical connections on the board (check for loose wires etc.). ▶ Check the code plug, if present, is not damaged. ▶ Replace the code plug, if present and required. ▶ Replace the control unit (PCB).
250	V	Default software error	<ul style="list-style-type: none"> ▶ Restart the appliance to see if problem re-occurs. ▶ Check the electrical connections on the board (check for loose wires etc.). ▶ Check the code plug, if present, is not damaged. ▶ Replace the code plug, if present and required. ▶ Replace the control unit (PCB).
251	V	Flash test error	<ul style="list-style-type: none"> ▶ Restart the appliance to see if the problem re-occurs. ▶ Check the electrical connections on the board (check for loose wires etc.). ▶ Check the code plug, if present, is not damaged. ▶ Replace the code plug, if present and required. ▶ Replace the control unit (PCB).
252	V	Stack overflow	<ul style="list-style-type: none"> ▶ Restart the appliance to see if the problem re-occurs. ▶ Check the electrical connections on the board (check for loose wires etc.). ▶ Check the code plug, if present, is not damaged. ▶ Replace the code plug, if present and required. ▶ Replace the control unit (PCB).
253	V	RAM test error	<ul style="list-style-type: none"> ▶ Restart the appliance to see if the problem re-occurs. ▶ Check the electrical connections on the board (check for loose wires etc.). ▶ Check the code plug, if present, is not damaged. ▶ Replace the code plug, if present and required. ▶ Replace the control unit (PCB).
254	V	Eeprom test error	<ul style="list-style-type: none"> ▶ Restart the appliance to see if the problem re-occurs. ▶ Check the electrical connections on the board (check for loose wires etc.). ▶ Check the code plug, if present, is not damaged. ▶ Replace the code plug, if present and required. ▶ Replace the control unit (PCB).
256	V	System fault boiler electronics / basic controller	<ul style="list-style-type: none"> ▶ Reset control unit / burner control unit - factory reset. ▶ Reconnect electrical connections at control unit correctly. ▶ Replace the control unit/burner control unit.
257	-	System fault boiler electronics / basic controller	<ul style="list-style-type: none"> ▶ Reset burner control - factory reset. ▶ Check electrical connections of burner control. ▶ Replace burner control.
258	V	Internal watchdog error	<ul style="list-style-type: none"> ▶ Restart the appliance to see if the problem re-occurs. ▶ Check the electrical connections on the board (check for loose wires etc.). ▶ Check the code plug, if present, is not damaged. ▶ Replace the code plug, if present and required. ▶ Replace the control unit (PCB).
259	V	AD reference error	<ul style="list-style-type: none"> ▶ Restart the appliance to see if the problem re-occurs. ▶ Check the electrical connections on the board (check for loose wires etc.). ▶ Check the code plug, if present, is not damaged. ▶ Replace the code plug, if present and required. ▶ Replace the control unit (PCB).
262	V	Internal OS error	<ul style="list-style-type: none"> ▶ Restart the appliance to see if the problem re-occurs. ▶ Check the electrical connections on board (check for loose wires etc.). ▶ Check the code plug, if present, is not damaged. ▶ Replace the code plug, if present and required. ▶ Replace the control unit (PCB).

Fault code	Fault category	Description	Remedy
263	V	Program sequence error	<ul style="list-style-type: none"> ▶ Restart the appliance to see if the problem re-occurs. ▶ Check the electrical connections on the board (check for loose wires etc.). ▶ Check the code plug, if present, is not damaged. ▶ Replace the code plug, if present and required. ▶ Replace the control unit (PCB).
264	B	Air handling failed during operation	<ul style="list-style-type: none"> ▶ Reconnect the fan plug properly, perform reset. ▶ Replace fan. ▶ Mains voltage must correspond to the default value. ▶ Remove any blockages in the flue system. ▶ Check venturi/injector for potential blockage.
265	O	Heat demand lower than energy supplied	Operating message, is not a fault.
268	O	Relay test was activated	Operating message, is not a fault.
269	V	Flame monitoring	<ul style="list-style-type: none"> ▶ Restart the appliance to see if the problem re-occurs. ▶ Check the electrical connections on the board (check for loose wires etc.). ▶ Replace the control unit (PCB).
270	O	Starting up boiler	Operating message, is not a fault.
273	O	Operation of burner and fan interrupted	Operating message, is not a fault.
275	O	Boiler electronics in test mode	Operating message, is not a fault.
281	B	Pump pressure increase too low	<ul style="list-style-type: none"> ▶ Check the flow pressure in system. ▶ Check the system for circulation issues (air locks, blockage, restriction). ▶ Check that the tacho/PWM plug, if present, for the circulation pump is fitted correctly. ▶ Check the tacho/PWM cable, if present, for continuity and replace the tacho/PWM cable if required. ▶ Replace the pump.
283	O	Burner starting	Operating message, is not a fault.
284	O	Opening air/gas ratio control valve/oil solenoid valves	Operating message, is not a fault.
305	O	Boiler in hot water anti-cycle mode	Anti-fast cycle mode, domestic hot water keep warm function. <ul style="list-style-type: none"> ▶ Diverter valve is held in the hot water position for a period of time. ▶ Check for false demands on the cold water inlet.
306	V	Flame signal after closing the fuel supply	<p>Tip: Ensure the working pressure returns immediately to the standing pressure when the gas valve closes.</p> <ul style="list-style-type: none"> ▶ Check the gas supply to the property and the inlet on the gas valve (check drop on inlet). ▶ Check the gas valve is not passing and replace if required. ▶ Replace the PCB.
323	-	BUS signal cannot be processed	<ul style="list-style-type: none"> ▶ Check connection to EMS controls, including 2-core cable if hard-wired. ▶ Check and replace PCB.
328	V	Brief mains voltage failure	▶ Check for voltage interruption between electrical wiring system of the building and the appliance.
341	B	Temperature rise at boiler too rapid	<ul style="list-style-type: none"> ▶ Open isolation valves. ▶ Connect plug to pump. ▶ Replace pump.
342	B	Temperature rise during hot water mode too rapid	<ul style="list-style-type: none"> ▶ If the water pressure is too low, top up with water and vent the system. ▶ Ensure isolation valves are open ▶ Check and replace diverter valve
350	B	Short-circuit at flow temp. sensor	<ul style="list-style-type: none"> ▶ Check and replace flow temperature sensor and harness. ▶ Check and replace the connecting lead to the flow temperature sensor. ▶ Check and replace control unit/burner control unit.
351	B	Flow temp. sensor interrupted	<ul style="list-style-type: none"> ▶ Connect the plug to the flow temperature sensor. ▶ Check and replace flow temperature sensor and harness. ▶ Check and replace the connecting lead to the flow temperature sensor. ▶ Check and replace control unit/burner control unit.
353	-	Test non-volatile lockout	Device may not start temporarily, never been off for 20 min for 24 h.
354	-	Test volatile lockout	Overpressure setting is detected.
356	B	Power supply for the boiler is too low	▶ Establish supply voltage of at least 196 VAC.
357	O	Ventilation program	Operating message, is not a fault: Venting program has been activated.

Fault code	Fault category	Description	Remedy
358	O	Anti-seizing functn. active	Operating message, is not a fault: blocking protection for the heating pump and the 3-way valve is active.
360	V	Incomparable code plug	If code plug is present: <ul style="list-style-type: none"> ▶ Check that correct plug is inserted. ▶ Check the code plug is not damaged. ▶ Replace the code plug if required. If code plug is not present: <ul style="list-style-type: none"> ▶ Check appliance electronics (PCB), replace if necessary.
362	V	Boiler identification module or boiler electronics faulty	<ul style="list-style-type: none"> ▶ Wrong code plug is inserted. ▶ Check the code plug is not damaged. ▶ Replace the code plug if required.
363	V	Ionisation current did not drop during ionisation test	<ul style="list-style-type: none"> ▶ Check and replace the ionisation cable. ▶ Check and replace the electrodes if required. ▶ Check and replace the control unit and/or burner control unit.
364	V	Solenoid valve ev2 leaking.	<ul style="list-style-type: none"> ▶ Check the gas valve, replace if required. ▶ Check electrodes and connecting leads, replace if required. ▶ Check and replace the appliance electronics.
365	V	Solenoid valve ev1 leaking.	<ul style="list-style-type: none"> ▶ Check the gas valve, replace if required. ▶ Check electrodes and connecting leads, replace if required. ▶ Check and replace the appliance electronics.
604	V	System fault burner control unit	<ul style="list-style-type: none"> ▶ Reset appliance - factory reset. ▶ If the fault persists following a reset, the burner control unit/PCB is faulty and must be replaced.
810	-	Hot water remains cold	<ul style="list-style-type: none"> ▶ Prevent water from escaping. ▶ Position DHW temperature sensor correctly. ▶ If current is not being supplied to the 3-way valve, there is a problem in the cable between the control panel and valve. Check screw terminals and cables. ▶ If current is being supplied to the 3-way valve but it is still not working, the valve is faulty and must be replaced. ▶ If a voltage of approx. 230 V is measured at the terminals and the pump is not running, the pump is faulty and must be replaced. ▶ Eliminate all faults in the cables. Vent if necessary. ▶ Replace the pump if there are any deviations whatsoever. ▶ Set the DHW heating to "Priority". ▶ If readings are different to the values in the table, replace the sensor.
1010	O	No BUS communication	<ul style="list-style-type: none"> ▶ Check the HMI for display and remove the HMI and the test voltage to the HMI. ▶ Check the HMI plug on far right of the PCB (low voltage connection). ▶ If using the Key: Check the Key connections (black, white, red, green) are plugged in to the correct position on the PCB. (Next to orange BUS connection leaving one space.) Check the pins on the plug. ▶ Check the bridging links are in LR & 230 V out. ▶ Replace the board. ▶ Check the 230 V external wiring does not run alongside the BUS connections.
1013	R	Max. combustion point reached	<ul style="list-style-type: none"> ▶ Check the maintenance menu. ▶ Reset the maintenance code via the reset menu.
1014	W	Actual ionisation is too low	Tip: Check the ceramic insulator is not damaged, this can cause the spark to earth, twist and pull the ceramic insulator to ensure it is not broken. <ul style="list-style-type: none"> ▶ Check the flame sense and the lead and replace if required. ▶ Check the earth tags on the boiler and on the electrodes. ▶ Check the operation of the siphon and no water collecting in the sump. ▶ Replace the air and/or gas ratio control valve. ▶ Replace the control unit and/or burner control unit.
1018	W	Maintenance interval expired	<ul style="list-style-type: none"> ▶ Check the maintenance date set in the menu. ▶ Reset the maintenance code via the reset menu.
1019		Incorrect pump type detected	<ul style="list-style-type: none"> ▶ Pump communication failure or wrong pump is fitted (non-ErP). ▶ Check the pump communication wire is connected and has continuity. ▶ Replace the pump for correct modulating pump.

Fault code	Fault category	Description	Remedy
1021	B	Cylinder charging or hot water temperature sensor faulty	<ul style="list-style-type: none"> ▶ Check the domestic hot water temperature sensor connected and the plug connected to temperature sensor. ▶ Check the resistance of the temperature sensor and replace if required. ▶ Check the continuity of harness and replace if required.
1023	R	Maximum run time including standby time reached	<ul style="list-style-type: none"> ▶ Check the maintenance menu. ▶ Reset the maintenance code via the reset menu.
1025	–	Return temp. sensor is faulty	Not fitted on the boiler.
1027	R	DHW pre-heat kit inlet sensor is disconnected	<ul style="list-style-type: none"> ▶ Check integrity of DHW pre-heat kit inlet sensor cable. ▶ Check connection of DHW pre-heat kit inlet sensor to correct port on control unit. ▶ Replace DHW pre-heat kit inlet sensor.
1037	W	Outside temp. sensor faulty - heating back-up operation active	<p>Tip: Check the weather compensation is applicable and the menu has not been accidentally switched on in the menu.</p> <ul style="list-style-type: none"> ▶ Check the positioning of the outside weather sensor. ▶ Check the weather sensor connections on the control board. ▶ Check the resistance of the sensor and the continuity down the cable and replace if required.
1068	W	Outside temp. sensor or lambda probe faulty	<ul style="list-style-type: none"> ▶ Check the outdoor sensor plug is connected. ▶ Check the resistance of the sensor and replace if required. ▶ Check the continuity of harness and replace if required. ▶ Replace the outdoor sensor.
1073	W	Short circuit of the flow temperature sensor	<ul style="list-style-type: none"> ▶ Check the flow temperature sensor plug is connected. ▶ Check the resistance of the flow temperature sensor and replace if required. ▶ Check the continuity of harness and replace if required. ▶ Replace the flow temperature sensor.
1074	W	No signal from flow temperature sensor	<ul style="list-style-type: none"> ▶ Check the flow temperature sensor plug is connected. ▶ Check the resistance of the flow temperature sensor and replace if required. ▶ Check the continuity of harness and replace if required. ▶ Replace the flow temperature sensor. ▶ Replace the PCB.
1075	W	Short-circuit heat exchanger temperature sensor	<ul style="list-style-type: none"> ▶ Check the temperature sensor plug is connected. ▶ Check the resistance of sensor and replace if required. ▶ Check the continuity of harness and replace if required. ▶ Replace the temperature sensor. ▶ Replace the PCB.
1076	W	No signal from heat exchanger temperature sensor	<ul style="list-style-type: none"> ▶ Replace the temperature sensor plug is connected. ▶ Check the resistance of sensor and replace if required. ▶ Check the continuity of harness and replace if required. ▶ Replace the temperature sensor. ▶ Replace the PCB.
2051	–	Internal fault	<ul style="list-style-type: none"> ▶ Disconnect power from the system for 30 seconds. ▶ Check and replace control unit. ▶ Notify customer service.
2085	V	Internal fault	<ul style="list-style-type: none"> ▶ Reset the appliance. ▶ Switch off the appliance for 30 s then turn back on. ▶ Check the incoming mains voltage. ▶ Check the polarity. ▶ Replace the PCB.
2908	V	System fault boiler electronics/basic controller	<ul style="list-style-type: none"> ▶ Restart the appliance to see if the problem re-occurs. ▶ If the fault remains after resetting: the burner controller (PCB) is defective and must be replaced.
2909	–	System fault boiler electronics / basic controller	<ul style="list-style-type: none"> ▶ If the fault persists following a reset, the burner control unit or Key (including interconnecting leads) is faulty and must be replaced.

Fault code	Fault category	Description	Remedy
2910	V	Error in the flue gas system. (Too much or too little resistance in air flow) <ul style="list-style-type: none"> the fan speed is higher than expected due too missing exhaust. the fan speed is to low due to an obstruction in the exhaust. 	Test Procedure: <ul style="list-style-type: none"> Check the flue gas system. Corrective/ Measure: <ul style="list-style-type: none"> Mount the flue gas pipe correctly. Remove the obstruction from flue gas pipe.
2911	V	Calibration failed	Tip: Check the ceramic insulator is not damaged, this can cause the spark to earth, twist and pull the ceramic insulator to ensure it is not broken. <ul style="list-style-type: none"> Check the flame sense and the lead and replace if required. Check the earth tags on the boiler and on the electrodes. Check the operation of the siphon and no water collecting in the sump. Replace the air and/or gas ratio control valve. Replace the control unit and/or burner control unit.
2912	V	No flame signal during calibration	Tip: Check the ceramic insulator is not damaged, this can cause the spark to earth, twist and pull the ceramic insulator to ensure it is not broken. <ul style="list-style-type: none"> Check the flame sense and the lead and replace if required. Check the earth tags on the boiler and on the electrodes. Check the operation of the siphon and no water collecting in the sump. Replace the air and/or gas ratio control valve. Replace the control unit and/or burner control unit.
2913	-	Flame signal too low during calibration	<ul style="list-style-type: none"> Check and replace flame sense electrodes (and interconnecting leads).
2914	-	There is no communication between the appliance controller and burner module	<ul style="list-style-type: none"> Restart the appliance to see if the problem re-occurs. If the fault remains after resetting: the burner controller (PCB) is defective.
2915	V	The fan keeps running after the post purge	<ul style="list-style-type: none"> Reset the appliance. Create a heat demand; check if the boiler fires up. Check the voltage to the fan and the continuity of the fan harness. Check the power modulation on the fan. PCB may be defective.
2916	V	Gas valve was detected to be open during post purge	<ul style="list-style-type: none"> Carry out a localised tightness test on the gas valve and replace if required. Check the voltage to gas valve. The gas valve or the PCB may have a fault.
2917	V	No flame signal when checking the combustion control	<ul style="list-style-type: none"> Disconnect power and then reconnect. Trigger heat demand. Wait 5 minutes. If the fault re-occurs within that time, reset the appliance without disconnecting the supply voltage. This triggers a calibration of the ionisation circuits. If the fault is still present after the calibration, the control unit is faulty and must be replaced.
2918	-	Fault in combustion control	<ul style="list-style-type: none"> Clean the siphon and drain water out of the appliance (gas side).
2920	V	Fault in flame monitoring	Possible PCB fault, no checks available.
2921	-	Boiler electr. in test mode	
2922	-	Internal fault	<ul style="list-style-type: none"> Check and replace control unit.
2923	V	Unexpected feedback from the modulating/ current controlled gas valve	Possible PCB fault, no checks available.
2924	V	No feedback from the gas valve	<ul style="list-style-type: none"> Check the voltage to the gas valve. Check the resistance of the gas valve coils. Check the continuity of harness and replace if required. The gas valve or the PCB may have a fault. Check gas valve cable and connectors.
2925	V	Too low feedback from the modulating gas valve	<ul style="list-style-type: none"> Check the voltage to the gas valve. Check the resistance of the gas valve coils. Check the continuity of harness and replace if required.
2926	V	Too high feedback from the modulating/ current controlled gas valve	<ul style="list-style-type: none"> Check the voltage to the gas valve. Check the resistance of the gas valve coils. Check the continuity of harness and replace if required. The gas valve or the PCB may have a fault.

Fault code	Fault category	Description	Remedy
2927	B	Flame failed during burner operation	<ul style="list-style-type: none"> ▶ Check the gas supply to the property and the inlet on the gas valve (check drop on inlet) and replace if required. ▶ Check the flame sense probe and the earth to the heat exchanger. ▶ Check the voltage to the gas valve and the continuity of harness and replace if required. ▶ Check the condition of the bearing plate. ▶ Check the flame sense plug is connected and the continuity of harness and replace if required. ▶ Check the fan pressure. ▶ Check the siphon trap and the discharge route. ▶ Check the flue integrity test.
2928	-	Internal error	<ul style="list-style-type: none"> ▶ Restart the appliance to see if the problem re-occurs. ▶ If the fault remains after resetting: the burner controller (PCB) is defective.
2930	V	System fault boiler electronics / basic controller	<ul style="list-style-type: none"> ▶ If the fault persists following a reset, the burner control unit is faulty and must be replaced.
2931	-	Illegal instruction executed by microcontroller	<ul style="list-style-type: none"> ▶ Restart the appliance to see if the problem re-occurs. ▶ If the fault remains after resetting: the burner controller (PCB) is defective.
2932	-	System fault boiler electronics / basic controller	<ul style="list-style-type: none"> ▶ Perform factory reset. ▶ If problem persists, replace PCB.
2940	V	Low voltage	<ul style="list-style-type: none"> ▶ Restart the appliance to see if the problem re-occurs. ▶ If the fault remains after resetting: the burner controller (PCB) is defective.
2941	B	Insuff. flow rate in boiler	<ul style="list-style-type: none"> ▶ Check plug of flow temperature sensor, connect correctly if required. ▶ Check flow temperature sensor, replace if necessary. ▶ Check pump for blockage, clear if required. ▶ Check water pressure, if necessary top up until the pre-set pressure is reached.
2942	-	No speed feedback signal from fan	<ul style="list-style-type: none"> ▶ Connect plug for speed control to the fan. ▶ Connect plug for power supply to the fan. ▶ Check fan harness. ▶ Check and replace control unit.
2943	-	Mains voltage too low	<ul style="list-style-type: none"> ▶ Establish supply voltage of at least 196 VAC.
2945	V	Too many short heat demands in short time period	<ul style="list-style-type: none"> ▶ Reset appliance - factory reset. ▶ Increase restart blocking time. ▶ Make sure that at least one thermostatic valve is open. ▶ Check and replace faulty heating pump. ▶ Check diverter valve functionality, replace if necessary.
2946	V	Incorrect code plug detected	<p>If code plug is present:</p> <ul style="list-style-type: none"> ▶ Check that correct plug is inserted. ▶ Check the code plug is not damaged. ▶ Check code plug against the part number. ▶ Replace the code plug if required. <p>If code plug is not present:</p> <ul style="list-style-type: none"> ▶ Check appliance electronics (PCB), replace if necessary.
2947	R	Incorrect code plug detected	The function stops automatically.
2948	B	No flame signal with low output	<p>The burner starts automatically after purging. It may cause strong winds.</p> <ul style="list-style-type: none"> ▶ If the fault occurs repeatedly: check the settings of the CO₂ values. ▶ Check the flue integrity. ▶ Check the flue terminal.
2949	B	No flame signal with high output	<p>It may cause strong winds or flue gas recirculation. The burner starts automatically after purging.</p> <ul style="list-style-type: none"> ▶ Check the flue integrity. ▶ Check the flue terminal position. ▶ Check the CO₂ settings and adjust. ▶ Check the burner and the heat exchanger gaskets and the inner flue gaskets. ▶ Check the gas pressure during burning at full load (working pressure, dropping low).
2950	B	No flame signal following starting procedure	<ul style="list-style-type: none"> ▶ Check the CO₂ settings and adjust. ▶ Check the burner and the heat exchanger gaskets. ▶ Check the gas pressure during burning at full load.

Fault code	Fault category	Description	Remedy
2951	V	Loss of flame too many times	Note: Front cover sealing issues can cause this fault. <ul style="list-style-type: none"> ▶ Refer to blocking errors(s) that lead to this locking error. Check the fault history on the appliance. ▶ Possibly the purging of the gas pipe is incomplete. ▶ It could also indicate a wide variety of issues such as pipework undersized or gas pressure dropping off, incorrectly routed condens drains, incorrectly sited flues, incorrectly wired etc.
2952	V	Internal fault when testing ionisation signal	<ul style="list-style-type: none"> ▶ Restart the appliance to see if the problem re-occurs. ▶ If the fault remains after resetting: the burner controller (PCB) is defective.
2953	B	No flame signal with low output.	The burner starts automatically after purging. Possible cause high winds. <ul style="list-style-type: none"> ▶ If the fault occurs repeatedly, check the settings of the CO₂ values. ▶ Check flue integrity. ▶ Check flue terminal.
2954	B	No flame signal with high output.	Burner restarts automatically after purging. <ul style="list-style-type: none"> ▶ Check and replace burner gaskets. ▶ Reduce burner load. ▶ If the fault occurs repeatedly, check the settings of the CO₂ values. ▶ Check flue integrity. ▶ Check flue terminal.
2955	B	Boiler does not support the parameters set for the hydraulic configuration	Verify that the following settings are correct. This can only be reset by powering off the appliance. <ul style="list-style-type: none"> ▶ Low loss header setting = OFF ▶ Internal DHW hydraulic = 1/ON ▶ Heat circuit 1 hydraulic = 1/ON ▶ CH hydraulic = 1/ON
2956	O	Hydraulic configuration at the boiler activated	Verify that the following settings are correct. This can only be reset by powering off the appliance. <ul style="list-style-type: none"> ▶ Low loss header setting = OFF ▶ Internal DHW hydraulic = 1/ON ▶ Heat circuit 1 hydraulic = 1/ON ▶ CH hydraulic = 1/ON
2957	V	Internal burner control error	<ul style="list-style-type: none"> ▶ Restart the appliance to see if the problem re-occurs. ▶ If the fault remains after resetting: the burner controller (PCB) is defective and must be replaced.
2958	V	System fault, appliance electronics.	<ul style="list-style-type: none"> ▶ Reset appliance electronics. ▶ Check electrical connections. ▶ Check and replace the control unit.
2959	B	System fault, appliance electronics.	<ul style="list-style-type: none"> ▶ Check and replace the control unit and code plug, if fitted.
2960	B	System fault, appliance electronics.	<ul style="list-style-type: none"> ▶ Check and replace the control unit and code plug, if fitted.
2961	V	No fan signal available	<ul style="list-style-type: none"> ▶ Check the mains voltage to the fan. ▶ Check the fan harness for continuity and replace if required. ▶ Replace the fan. ▶ Replace the PCB.
2962	V	Fan not running	<ul style="list-style-type: none"> ▶ Check the mains voltage to the fan. ▶ Check the fan harness for continuity and replace if required. ▶ Replace the fan. ▶ Replace the PCB.
2963	B	Signal from flow and heat exchanger temperature sensor outside the permissible range	<ul style="list-style-type: none"> ▶ Check the flow through the appliance and that the system is filled. ▶ Check for air locks in the system and purge if required. ▶ Check the heat exchanger sensor (primary thermistor) and the plug connected to the temperature sensor. ▶ Check the resistance of the temperature sensor and replace if required. ▶ Check the continuity of the harness and replace if required.

Fault code	Fault category	Description	Remedy
2964	B	Flow rate in heat exchanger too low	<ul style="list-style-type: none"> ▶ Check the flow through the appliance and that the system is filled. ▶ Check for air locks in the system and purge if required. ▶ Check the heat exchanger sensor (primary thermistor) and the plug connected to the temperature sensor. ▶ Check the resistance of the temperature sensor and replace if required. ▶ Check the continuity of the harness and replace if required.
2965	B	Flow temperature too high	<ul style="list-style-type: none"> ▶ Check the flow through the appliance and the system is filled. ▶ Check for the air locks in the system and purge if required. ▶ Check the isolation valves.
2966	B	Flow temperature rise in heat exchanger too rapid	<ul style="list-style-type: none"> ▶ Check the flow through the appliance and the system is filled. ▶ Check for the air locks in the system and purge if required. ▶ Check the isolation valves. ▶ Check the pump is operating freely and check the voltage to the pump.
2967	B	Flow/heat exchanger temperature sensor differential too great	<ul style="list-style-type: none"> ▶ Check the flow through the appliance and the system is filled. ▶ Check for air locks in the system and purge if required. ▶ Check the isolation valves. ▶ Check the pump is operating freely and check the voltage to the pump. ▶ Check the heat exchanger sensor and the flow sensor are making contact with the pipework. ▶ Check the heat exchanger sensor and the resistance of the temperature sensor and replace if required. ▶ Check the continuity of harness and replace if required.
2971	B	System pressure too low	<p>Compare to internal pressure dial maximum 0.7 bar pressure differential between them. Top up water until the pre-set pressure reached.</p> <p>Intelligent filling loop</p> <ul style="list-style-type: none"> ▶ Switch off the intelligent fill in the system menu, re-pressurise manually and vent the system. ▶ Ensure the correct pressure then factory rest appliance. If cause code does not clear power off appliance. <p>Other filling loop</p> <ul style="list-style-type: none"> ▶ Vent the heating system and top up water until the pre-set pressure reached. <p>Pressure sensor</p> <ul style="list-style-type: none"> ▶ Check the continuity down harness for the pressure sensor and replace if required. ▶ Check the voltage at the pressure sensor and replace if required.
2972	-	Mains voltage too low	Check the mains voltage on the appliance (L and N).
2973	-	System fault boiler electronics / basic controller	<ul style="list-style-type: none"> ▶ Perform factory reset. ▶ Check and replace control unit.
2974	-	Internal fault	<ul style="list-style-type: none"> ▶ Restart the appliance and check if fault remains. ▶ Check and replace control unit.
2981	V	Locking fault(Boiler locked. Contact a qualified heating engineer)	<ul style="list-style-type: none"> ▶ Diagnose and remedy the locking fault. Check the complete system, including sensors and harnesses. ▶ When remedied and system checked, turn the boiler power off and on again. ▶ Fault condition 2981 will appear, the boiler is still in super lock-out. ▶ Press the up and down arrows simultaneously for 3 seconds. ▶ Immediately after 22 seconds have elapsed, perform an additional reset by pressing the up and down arrows simultaneously for 3 seconds. ▶ Super lock-out is remedied, boiler returns to normal operating condition. ▶ Fault history is now available, double check the last 10 faults to confirm the fault has been remedied.
3071	-	Comfort + II RF	<ul style="list-style-type: none"> ▶ Check the configuration (address setting). The selected setting requires a remote control. ▶ Check the EMS connection cable for the remote control for damage. The BUS voltage on the remote control must be between 12 and 15 V DC. ▶ The remote control is defective.

Table 39 Indicators and fault displays

11.3 Pump operation and diagnosis

The operation/fault indicator () will indicate the status of the pump including any errors detected.

LED colour	Description	Diagnostic	Potential cause	Remedy
Green - continuous	Normal operation	Pump runs as expected	Normal operation	--
Green/Red - blinking	Warning mode (pump operating in an abnormal condition, no risk for the pump functionality).	The pump is running but sent a warning message.	<ul style="list-style-type: none"> • Dry run: <ul style="list-style-type: none"> – The pump is operating without water. 	▶ Check appliance system pressure and top up as required.
			<ul style="list-style-type: none"> • Overload of motor: <ul style="list-style-type: none"> – Friction due to particles and/or impeller blocked with debris and/or too high viscosity. 	▶ Check installation water quality, clean system if debris is present.
			<ul style="list-style-type: none"> • Generator operation: <ul style="list-style-type: none"> – The pump rotor is driven by an external flow. 	▶ The pump will operate normally when the external flow will be stopped.
Red - blinking	Abnormal running mode (pump stopped but still functioning).	The pump has stopped due to external failure. The pump will restart itself after the disappearance of the external failure.	<ul style="list-style-type: none"> • Under or Over voltage: <ul style="list-style-type: none"> – Mains supply voltage $U < 160V$ or $U > 280V$. 	▶ Check mains voltage supply to pump: $160V < U < 280V$.
			<ul style="list-style-type: none"> • Overload of motor: <ul style="list-style-type: none"> – Friction due to particles and/or impeller blocked with debris and/or too high viscosity. 	▶ Check installation water quality, clean system if debris.
			<ul style="list-style-type: none"> • Over speed: <ul style="list-style-type: none"> – The pump rotor is driven by an external flow above the maximum allowed value. 	▶ Ensure that there is no other external flow (additional secondary pump running) on the system.
			<ul style="list-style-type: none"> • Over current: <ul style="list-style-type: none"> – Abnormal current exceeding the limit. 	▶ Check for leakage on appliance.
			<ul style="list-style-type: none"> • Module over temperature: <ul style="list-style-type: none"> – Temperature inside the motor is too high. 	▶ Check for evidence of dry running, low system pressure and ambient temperature.
			<ul style="list-style-type: none"> • Turbine mode: <ul style="list-style-type: none"> – The pump is driven by external flow ($> 1200l/h$) in opposite direction of its flow. 	▶ Ensure that the external flow is less than 1200l/h.
			<ul style="list-style-type: none"> • Faulty electronic module and/or faulty motor. 	▶ Restart the appliance and wait 30 seconds before switching back ON. ▶ Replace pump if LED is still red after power restart.
No LED	No power supply	No voltage on electronics	<ul style="list-style-type: none"> • Pump is not connected to mains supply 	▶ Check cable connection and supply to pump.
			<ul style="list-style-type: none"> • Faulty LED 	▶ Check if pump is running.
			<ul style="list-style-type: none"> • Faulty electronics 	▶ Replace pump.

Table 40 Pump operation and diagnosis

11.4 Faults that are not displayed

Appliance faults	Remedy
Combustion noises too loud; rumbling noises.	<ul style="list-style-type: none"> ▶ Check the gas type. ▶ Check the gas supply pressure. ▶ Check the flue system; clean or repair if required. ▶ Check the gas/air ratio. ▶ Check the ratio control valve; replace if required. ▶ Check condense drain is clear. ▶ Check fan depression.
Heat-up takes too long.	<ul style="list-style-type: none"> ▶ Check system is balanced. ▶ Check anti-cycle time.
Flue gas values incorrect; CO content too high.	<ul style="list-style-type: none"> ▶ Check the gas type. ▶ Check the gas supply pressure. ▶ Check the flue system; clean or repair if required. ▶ Check the gas/air ratio. ▶ Check the ratio control valve; replace if required.
Delayed ignition, poor ignition.	<ul style="list-style-type: none"> ▶ Check the ignition transformer function for misfiring in Menu 6, replace if required. ▶ Check the gas type. ▶ Check the gas supply pressure. ▶ Check operation of meter governor. ▶ Check the power supply. ▶ Check the electrodes; replace if required. ▶ Check the flue system; clean or repair if required. ▶ Check the gas/air ratio. ▶ Check the burner, replace if required. ▶ Check the air/gas ratio control valve; replace if required.
Condensate in air box.	<ul style="list-style-type: none"> ▶ Check the non-return valve in the air/gas manifold, replace if required.
No hot water.	<ul style="list-style-type: none"> ▶ Check the turbine, replace if required. ▶ Check diverter valve. ▶ Check for cross-piping.
DHW volume is not reached.	<ul style="list-style-type: none"> ▶ Check the plate heat exchanger. ▶ Check flow device. ▶ Check silencer body.
No function, the display remains dark.	<ul style="list-style-type: none"> ▶ Check the electrical wiring for damage. ▶ Replace defective cables. ▶ Check the fuse, replace if required.

Table 41 Faults that are not shown on the display

12 Environmental protection and disposal

Environmental protection is a fundamental corporate strategy of the Bosch Group.

The quality of our products, their economy and environmental safety are all of equal importance to us and all environmental protection legislation and regulations are strictly observed.

We use the best possible technology and materials for protecting the environment taking account of economic considerations.

Packaging

Where packaging is concerned, we participate in country-specific recycling processes that ensure optimum recycling.

All of our packaging materials are environmentally compatible and can be recycled.

Used appliances

Used appliances contain valuable materials that can be recycled.

The various assemblies can be easily dismantled. Synthetic materials are marked accordingly. Assemblies can therefore be sorted by composition and passed on for recycling or disposal.

Old electrical and electronic appliances



This symbol means that the product must not be disposed of with other waste, and instead must be taken to the waste collection points for treatment, collection, recycling and disposal.



The symbol is valid in countries where waste electrical and electronic equipment regulations apply, e.g. "(UK) Waste Electrical and Electronic Equipment Regulations 2013 (as amended)". These regulations define the framework for the return and recycling of old electronic appliances that apply in each country.

As electronic devices may contain hazardous substances, it needs to be recycled responsibly in order to minimize any potential harm to the environment and human health. Furthermore, recycling of electronic scrap helps preserve natural resources.

For additional information on the environmentally compatible disposal of old electrical and electronic appliances, please contact the relevant local authorities, your household waste disposal service or the retailer where you purchased the product.

You can find more information here:

www.weee.bosch-thermotechnology.com/

Batteries

Batteries must not be disposed together with your household waste.

Used batteries must be disposed of in local collection systems.

13 Technical Specifications/Logs

13.1 Technical data

Technical data table - Greenstar 2000 NG

Greenstar 2000	Unit	25kW NG	GR2301iW Low NOx 25kW/30kW	30kW NG	
Gas flow maximum rate - 10 minutes from lighting					
Gas inlet pressure (nominal) ¹⁾	mbar	20.0	20.0	20.0	
Natural gas ²⁾	m ³ /h	2.62	2.62/3.05	3.05	
Central Heating (CH)					
Maximum rated heat input (net) (Q _{max})	kW	24.5	13.3	24.5	
Maximum rated heat output 40/30 °C	kW	25.2	14.2	25.2	
Maximum rated heat output 50/30 °C (P _{cond, max})	kW	25.0	14.1	25.0	
Maximum rated heat output 80/60 °C (P _{max})	kW	24.0	13.0	24.0	
Minimum rated heat input (net) (Q _{min})	kW	3.1	3.1	3.1	
Minimum rated heat output 40/30 °C	kW	3.4	3.4	3.4	
Minimum rated heat output 50/30 °C (P _{cond, min})	kW	3.4	3.4	3.4	
Minimum rated heat output 80/60 °C (P _{min})	kW	3.0	3.0	3.0	
Maximum flow temperature	°C	86	86	86	
Maximum flow temperature possible	°C	82	82	82	
Maximum permissible operating pressure (PMS)	bar	3.0	3.0	3.0	
Available pump head at 20 °C system temperature rise	m	2	2	2	
Domestic Hot Water (DHW)					
Minimum heat input	kW	3.1	Low NOx only applies to Central Heating	3.1	
Maximum rated heat input (net) (Q _{nW})	kW	25.5		30	
Maximum rated heat output (P _{nW})	kW	25.0		29.4	
Maximum mains inlet pressure (standing pressure PMW)	bar	10		10	
Minimum mains inlet pressure (working) for max. flow	bar	1.5		1.5	
Minimum mains inlet pressure (working) for operation	bar	0.3		0.3	
Minimum required flow to activate DHW demand	l/min	2.5		2.5	
DHW temperature range	°C	35 - 60		35 - 60	
Maximum cold water inlet temperature	°C	30		30	
Maximum DHW flow rate - 35 °C rise ± 15% ³⁾	l/min	10		12	
Maximum DHW flow rate - 40 °C rise ± 15%	l/min	9		10.8	
Flue					
Flue gas temperature max. load DHW demand	°C	70		75/70	75
Flue gas temperature 80/60 °C, rated/min. load	°C	69/56	62/56	69/56	
Flue gas temperature 40/30 °C, rated/min. load	°C	49/35	39/35	49/35	
CO ₂ level at max. rated heat output (after 10 minutes)	%	9.4	9.3	9.4	
CO ₂ level at min. rated heat output (after 10 minutes)	%	8.6	8.6	8.6	
NOx Class	–	6	6	6	
NOx rating (EN 15502-1)	mg/kWh	40	30	40	
Condensate					
Maximum condensate rate	l/h	1.7	1.7	1.7	
pH value, approx.	–	4.8	4.8	4.8	
Electrical					
Electrical power supply voltage	a.c. V	230	230	230	
Frequency	Hz	50	50	50	
Maximum power consumption (running)	W	105	105/123	123	
Maximum power consumption (stand-by)	W	3	3	3	
Energy efficiency index (EEI) heating pump	–	≤ 0.2	≤ 0.2	≤ 0.2	

Greenstar 2000 Description	Unit	25kW NG	GR2301iW Low NOx 25kW/30kW	30kW NG
General data				
Expansion vessel capacity	l	6	6	6
Expansion vessel pre-charge pressure	bar	0.75	0.75	0.75
Appliance protection rating ⁴⁾	IP	X4D	X4D	X4D
Permissible ambient temperature short-term/long-term	°C	0-50/40	0-50/40	0-50/40
Nominal capacity of the appliance	l	7	7	7
Total package weight	kg	40	40	40
Total appliance weight (excluding packaging)	kg	36	36	36
Lift weight (without front panel)	kg	33	33	33
SEDBUK 2009/12	%	89.4	89.4	89.4

- 1) For minimum and maximum permissible pressure refer to "Gas pressure within the system", section 6.6.
- 2) The Gas Rate provided assumes the accepted NG averaged calorific value of 34.9 MJ/m³ net.
- 3) Appliances are fitted with a flow regulator set to achieve a 35°C temperature rise. A 40°C temperature rise is possible at lower flow rates.
- 4) Protection rating may change depending on the control unit/s used on this appliance.

Table 42 Technical data Greenstar 2000 NG

Technical data table - Greenstar 2000 LPG

Greenstar 2000 Description	Unit	GR2301iW	
		25kW LPG	30kW LPG
Gas flow maximum rate - 10 minutes from lighting			
Gas inlet pressure (nominal) ¹⁾	mbar	37.0	37.0
Propane (Hi=12.9kWh/ m ³) ²⁾	kg/m ³	1.89	2.21
Central Heating (CH)			
Maximum rated heat input (net) (Q _{max})	kW	24.5	24.5
Maximum rated heat output 40/30 °C	kW	25.2	25.2
Maximum rated heat output 50/30 °C (P _{cond, max})	kW	25.0	25.0
Maximum rated heat output 80/60 °C (P _{max})	kW	24.0	24.0
Minimum rated heat input (net) (Q _{min})	kW	3.1	3.1
Minimum rated heat output 40/30 °C	kW	3.4	3.4
Minimum rated heat output 50/30 °C (P _{cond, min})	kW	3.4	3.4
Minimum rated heat output 80/60 °C (P _{min})	kW	3.0	3.0
Maximum flow temperature	°C	86	86
Maximum flow temperature possible	°C	82	82
Maximum permissible operating pressure (PMS)	bar	3.0	3.0
Available pump head at 20 °C system temperature rise	m	2	2
Domestic Hot Water (DHW)			
Minimum heat input	kW	3.1	3.1
Maximum rated heat input (net) (Q _{nW})	kW	25.5	30
Maximum rated heat output (P _{nW})	kW	25.0	29.4
Maximum mains inlet pressure (standing pressure PMW)	bar	10	10
Minimum mains inlet pressure (working) for max. flow	bar	1.5	1.5
Minimum mains inlet pressure (working) for operation	bar	0.3	0.3
Minimum required flow to activate DHW demand	l/min	2.5	2.5
DHW temperature range	°C	35 - 60	35 - 60
Maximum cold water inlet temperature	°C	30	30
Maximum DHW flow rate - 35 °C rise ± 15% ³⁾	l/min	10	12
Maximum DHW flow rate - 40 °C rise ± 15%	l/min	9	10.8
Flue			
Flue gas temperature max. load DHW demand	°C	70	75
Flue gas temperature 80/60 °C, rated/min. load	°C	69/56	69/56
Flue gas temperature 40/30 °C, rated/min. load	°C	49/35	49/35
CO ₂ level at max. rated heat output (after 10 minutes)	%	10.8	10.8
CO ₂ level at min. rated heat output (after 10 minutes)	%	10.2	10.2
NOx Class	–	6	6
NOx rating (EN 15502-1)	mg/kWh	65	65
Condensate			
Maximum condensate rate	l/h	1.7	1.7
pH value, approx.	–	4.8	4.8
Electrical			
Electrical power supply voltage	a.c. V	230	230
Frequency	Hz	50	50
Maximum power consumption (running)	W	105	123
Maximum power consumption (stand-by)	W	3	3
Energy efficiency index (EEI) heating pump	–	≤ 0.2	≤ 0.2
General data			
Expansion vessel capacity	l	6	6
Expansion vessel pre-charge pressure	bar	0.75	0.75
Appliance protection rating ⁴⁾	IP	X4D	X4D
Permissible ambient temperature short-term/long-term	°C	0-50/40	0-50/40
Nominal capacity of the appliance	l	7	7
Total package weight	kg	40	40
Total appliance weight (excluding packaging)	kg	34.7	34.7
Lift weight (without front panel)	kg	32.1	32.1
SEDBUK 2009	%	90.4	90.4

1) For minimum and maximum permissible pressure refer to "Gas pressure within the system", section 6.6.

2) Propane/butane mixture for fixed containers with capacity up to 15 000 litres.

- 3) Appliances are fitted with a flow regulator set to achieve a 35°C temperature rise. A 40°C temperature rise is possible at lower flow rates.
- 4) Protection rating may change depending on the control unit/s used on this appliance.

Table 43 Technical data Greenstar 2000 LPG

13.2 Component resistance characteristics

13.2.1 Sensor values

Temperature [°C ± 10%]	Resistance [Ω]
0	33 404
5	25 902
10	20 247
15	15 950
20	12 657
25	10 115
30	8 138
35	6 589
40	5 367
45	4 398
50	3 624
55	3 002
60	2 500
65	2 092
70	1 759
75	1 486
80	1 260
85	1 074
90	918
95	788
100	680

Table 44 Flow temperature sensor

Temperature [°C]	Resistance [Ω]
0	33 242
10	19 947
20	12 394
30	7 947
40	5 242
50	3 548
60	2 459
70	1 740
80	1 256
90	923

Table 45 DHW temperature sensor

Temperature [°C]	Resistance [Ω]
-40	≥ 4 111
-30	3 218
-20	2 360
-10	1 650
0	1 122
10	759
20	515
30	354
40	247
50	≤ 174

Table 46 Outside temperature sensor (for weather-compensated controllers, accessory)

13.3 Heating curve

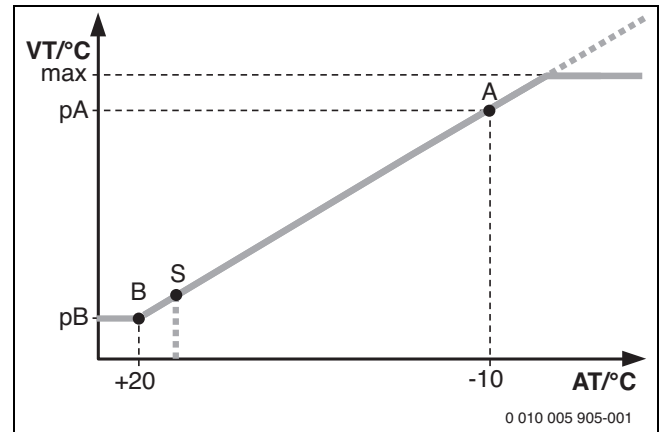

Fig. 116 Heating curve

- A End point (at the outside temperature - 10°C)
- AT Outdoor ambient temperature
- B Base point (at the outside temperature + 20°C)
- max Maximum flow temperature
- pA Flow temperature at the end point of the heating curve
- pB Flow temperature at the foot point of the heating curve
- S Automatic heating switch-off (summer mode)
- VT Supply temperature

13.4 Internal wiring of the appliance

13.4.1 Electrical wiring

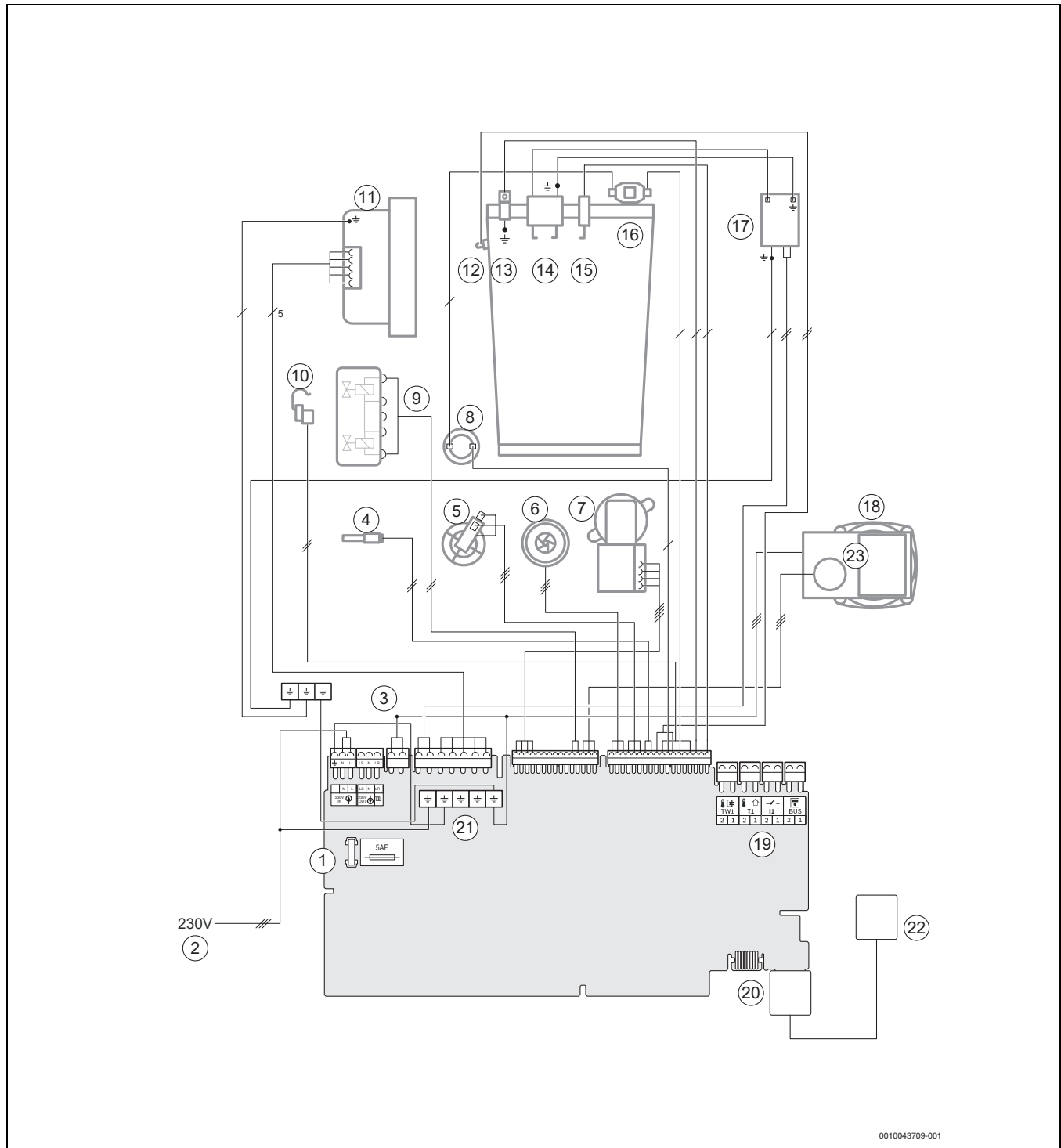

Fig. 117 Electrical wiring

Legend to figure 117:

- | | |
|-------------------------------------|---|
| [1] Fuse | [12] Heat exchanger flow temperature sensor |
| [2] Mains cable | [13] Earth connection |
| [3] Earth connections | [14] Ignition electrode |
| [4] DHW temperature sensor | [15] Flame sense electrode |
| [5] Pressure sensor | [16] Heat exchanger high limit stat |
| [6] Flow limiter cartridge | [17] Ignition transformer |
| [7] Diverter valve | [18] Pump 230V supply |
| [8] Exhaust gas temperature limiter | [19] Low voltage I/Os for controls |
| [9] Gas valve | [20] Code plug interface - Not used |
| [10] Flow temperature sensor | [21] Earthing bracket |
| [11] Fan | [22] KEY |
| | [23] Pump control signal |

13.5 Setting values for output

The maximum rated heat output can be reduced to up to 50 % of the output range (→service function 3-b1).

The minimum rated heat output can be increased to up to 50 % of the output range (→service function 5-A3).

13.5.1 Gas setting values (Natural Gas)

GR2301iW 25 C (NG)

Display percentage %	Heat Output [kW]	Heat input [kW]	Gas flow rate [l/min]
96	24,00	24,50	41,90
95	23,80	24,24	41,50
90	22,50	22,97	39,30
85	21,20	21,69	37,10
80	20,00	20,42	34,90
75	18,70	19,14	32,70
70	17,50	17,86	30,60
65	16,20	16,59	28,40
60	15,00	15,31	26,20
55	13,70	14,04	24,00
50	12,50	12,76	21,80
45	11,20	11,48	19,60
40	10,00	10,21	17,50
35	8,70	8,93	15,30
30	7,50	7,66	13,10
25	6,20	6,38	10,90
20	5,00	5,10	8,70
15	3,70	3,83	6,50
12	3,00	3,07	5,50

Table 47 GR2301iW 25 C

GR2301iW 30 C (NG)

Display percentage %	Heat output [kW]	Heat input [kW]	Gas flow rate [l/min]
82	24,00	24,50	41,90
80	23,40	23,90	40,90
75	21,90	22,40	38,30
70	20,50	20,90	35,80
65	19,00	19,40	33,20
60	17,50	17,90	30,70
55	16,10	16,40	28,10
50	14,60	14,90	25,50
45	13,10	13,40	23,00
40	11,70	12,00	20,40
35	10,20	10,50	17,90
30	8,80	9,00	15,30
25	7,30	7,50	12,80
20	5,80	6,00	10,20
15	4,40	4,50	7,70
10	3,00	3,10	5,50

Table 48 GR2301iW 30 C

GAS BOILER SYSTEM COMMISSIONING CHECKLIST & WARRANTY VALIDATION RECORD

Address:													
Boiler make and model:													
Boiler serial number:													
Commissioned by (PRINT NAME):						Gas Safe registration number:							
Company name:						Telephone number:							
Company email:						Company address:							
										Commissioning date:			
Heating and hot water system complies with the appropriate Building Regulations?											Yes		
Optional: Building Regulations Notification Number (if applicable):													
Time, temperature control and boiler interlock provided for central heating and hot water											Yes		
Boiler Plus requirements (tick the appropriate box(s))													
Boiler Plus option chosen for combination boiler in ENGLAND						Weather compensation			Smart thermostat with automation and optimisation				
						Load compensation			Flue Gas Heat Recovery				
Time and temperature control to hot water		Cylinder thermostat and programmer/timer						Combination boiler					
Zone valves		pre-existing		Fitted		Not required							
Thermostatic radiator valves		pre-existing		Fitted		Not required							
Automatic bypass to system		pre-existing		Fitted		Not required							
Underfloor heating		pre-existing		Fitted		Not required							
Water quality													
The system has been flushed, cleaned and a suitable inhibitor applied upon final fill, in accordance with BS7593 and boiler manufacturers' instructions											Yes		
What system cleaner was used?						Brand:			Product:				
What inhibitor was used?						Brand:			Product:				
Primary water system filter		pre-existing		Fitted		Not required							
CENTRAL HEATING MODE measure and record (as appropriate)													
Gas rate (for combination boilers complete DHW mode gas rate)				m ³ /hr		or		ft ³ /hr					
Central heating output left at factory settings?											Yes	No	
If no, what is the maximum central heating output selected?											kW		
Dynamic gas inlet pressure											mbar		
Central heating flow temperature											°C		
Central heating return temperature											°C		
System correctly balanced/rebalanced?											Yes		
COMBINATION BOILERS ONLY													
Is the installation in a hard water area (above 200ppm)?											Yes	No	
Water scale reducer/softener		pre-existing		Fitted		Not required							
What type of scale reducer/softener has been fitted?						Brand:			Product:				
Water meter fitted?											Yes	No	
If yes- DHW expansion vessel		pre-existing		Fitted		Not required							
Pressure reducing valve		pre-existing		Fitted		Not required							
DOMESTIC HOT WATER MODE Measure and record													
Gas rate				m ³ /hr		or		ft ³ /hr					
Dynamic gas inlet pressure at maximum rate											mbar		
Cold water inlet temperature											°C		
Hot water has been checked at all outlets											Yes	Temperature	°C
CONDENSATE DISPOSAL													
The condensate drain has been installed in accordance with the manufacturers' instructions and/or BS5546/BS6798											Yes		
Point of termination						Internal			External (only where internal termination impractical)				
Method of disposal						Gravity			Pumped				
ALL INSTALLATIONS													
Record the following		At max rate:		CO ppm		CO ₂ %		CO/CO ₂		Ratio			
		At min rate (where possible)		CO ppm		CO ₂ %		CO/CO ₂		Ratio			
Where possible, has a flue integrity check been undertaken in accordance with manufacturers' instructions, and readings are correct?											Yes		
The operation of the boiler and system controls have been demonstrated to and understood by the customer											Yes		
The manufacturers' literature, including Benchmark Checklist and Service Record, has been explained and left with the customer											Yes		
Commissioning Engineer's signature													
Customer's signature (To confirm satisfactory demonstration and receipt of manufacturers' literature)													

* All installations in England and Wales must be notified to Local Authority Building Control (LABC) either directly or through a Competent Persons Scheme. A Building Regulations Compliance Certificate will then be issued to the customer.



13.7 Inspection and maintenance checklist

Inspection and maintenance checklist		Year 1	Year 2	Year 3	Year 4	Year 5	Year 6	Year 7	Year 8	Year 9	Year 10	Year 11	Year 12	Year 13	Year 14	Year 15
	Date:															
1	Check appliance operation (CH & DHW) and fault history	Yes <input type="checkbox"/>	Yes <input type="checkbox"/>	Yes <input type="checkbox"/>	Yes <input type="checkbox"/>	Yes <input type="checkbox"/>	Yes <input type="checkbox"/>	Yes <input type="checkbox"/>	Yes <input type="checkbox"/>	Yes <input type="checkbox"/>	Yes <input type="checkbox"/>	Yes <input type="checkbox"/>	Yes <input type="checkbox"/>	Yes <input type="checkbox"/>	Yes <input type="checkbox"/>	Yes <input type="checkbox"/>
2	Visual Inspection:- Check compliance of appliance, system and components	Yes <input type="checkbox"/>	Yes <input type="checkbox"/>	Yes <input type="checkbox"/>	Yes <input type="checkbox"/>	Yes <input type="checkbox"/>	Yes <input type="checkbox"/>	Yes <input type="checkbox"/>	Yes <input type="checkbox"/>	Yes <input type="checkbox"/>	Yes <input type="checkbox"/>	Yes <input type="checkbox"/>	Yes <input type="checkbox"/>	Yes <input type="checkbox"/>	Yes <input type="checkbox"/>	Yes <input type="checkbox"/>
3	Internal visual inspection Check for signs of leaking, corrosion and distress	Yes <input type="checkbox"/>	Yes <input type="checkbox"/>	Yes <input type="checkbox"/>	Yes <input type="checkbox"/>	Yes <input type="checkbox"/>	Yes <input type="checkbox"/>	Yes <input type="checkbox"/>	Yes <input type="checkbox"/>	Yes <input type="checkbox"/>	Yes <input type="checkbox"/>	Yes <input type="checkbox"/>	Yes <input type="checkbox"/>	Yes <input type="checkbox"/>	Yes <input type="checkbox"/>	Yes <input type="checkbox"/>
4	Appliance performance checks:															
4.1	Check Fan pressure test was cleaning required?	Yes <input type="checkbox"/>	Yes <input type="checkbox"/>	Yes <input type="checkbox"/>	Yes <input type="checkbox"/>	Yes <input type="checkbox"/>	Yes <input type="checkbox"/>	Yes <input type="checkbox"/>	Yes <input type="checkbox"/>	Yes <input type="checkbox"/>	Yes <input type="checkbox"/>	Yes <input type="checkbox"/>	Yes <input type="checkbox"/>	Yes <input type="checkbox"/>	Yes <input type="checkbox"/>	Yes <input type="checkbox"/>
		No <input type="checkbox"/>	No <input type="checkbox"/>	No <input type="checkbox"/>	No <input type="checkbox"/>	No <input type="checkbox"/>	No <input type="checkbox"/>	No <input type="checkbox"/>	No <input type="checkbox"/>	No <input type="checkbox"/>	No <input type="checkbox"/>	No <input type="checkbox"/>	No <input type="checkbox"/>	No <input type="checkbox"/>	No <input type="checkbox"/>	No <input type="checkbox"/>
		Yes <input type="checkbox"/>	Yes <input type="checkbox"/>	Yes <input type="checkbox"/>	Yes <input type="checkbox"/>	Yes <input type="checkbox"/>	Yes <input type="checkbox"/>	Yes <input type="checkbox"/>	Yes <input type="checkbox"/>	Yes <input type="checkbox"/>	Yes <input type="checkbox"/>	Yes <input type="checkbox"/>	Yes <input type="checkbox"/>	Yes <input type="checkbox"/>	Yes <input type="checkbox"/>	Yes <input type="checkbox"/>
4.2	Check and clean syphon	Yes <input type="checkbox"/>	Yes <input type="checkbox"/>	Yes <input type="checkbox"/>	Yes <input type="checkbox"/>	Yes <input type="checkbox"/>	Yes <input type="checkbox"/>	Yes <input type="checkbox"/>	Yes <input type="checkbox"/>	Yes <input type="checkbox"/>	Yes <input type="checkbox"/>	Yes <input type="checkbox"/>	Yes <input type="checkbox"/>	Yes <input type="checkbox"/>	Yes <input type="checkbox"/>	Yes <input type="checkbox"/>
4.3	Correct working gas inlet pressure	Yes <input type="checkbox"/>	Yes <input type="checkbox"/>	Yes <input type="checkbox"/>	Yes <input type="checkbox"/>	Yes <input type="checkbox"/>	Yes <input type="checkbox"/>	Yes <input type="checkbox"/>	Yes <input type="checkbox"/>	Yes <input type="checkbox"/>	Yes <input type="checkbox"/>	Yes <input type="checkbox"/>	Yes <input type="checkbox"/>	Yes <input type="checkbox"/>	Yes <input type="checkbox"/>	Yes <input type="checkbox"/>
4.4	Fue gas analysis Check combustion settings: Min/Max test modes	Yes <input type="checkbox"/>	Yes <input type="checkbox"/>	Yes <input type="checkbox"/>	Yes <input type="checkbox"/>	Yes <input type="checkbox"/>	Yes <input type="checkbox"/>	Yes <input type="checkbox"/>	Yes <input type="checkbox"/>	Yes <input type="checkbox"/>	Yes <input type="checkbox"/>	Yes <input type="checkbox"/>	Yes <input type="checkbox"/>	Yes <input type="checkbox"/>	Yes <input type="checkbox"/>	Yes <input type="checkbox"/>
4.5	Gas rate appliance at maximum output in test mode	Yes <input type="checkbox"/>	Yes <input type="checkbox"/>	Yes <input type="checkbox"/>	Yes <input type="checkbox"/>	Yes <input type="checkbox"/>	Yes <input type="checkbox"/>	Yes <input type="checkbox"/>	Yes <input type="checkbox"/>	Yes <input type="checkbox"/>	Yes <input type="checkbox"/>	Yes <input type="checkbox"/>	Yes <input type="checkbox"/>	Yes <input type="checkbox"/>	Yes <input type="checkbox"/>	Yes <input type="checkbox"/>
4.6	Check flame failure appliance	Yes <input type="checkbox"/>	Yes <input type="checkbox"/>	Yes <input type="checkbox"/>	Yes <input type="checkbox"/>	Yes <input type="checkbox"/>	Yes <input type="checkbox"/>	Yes <input type="checkbox"/>	Yes <input type="checkbox"/>	Yes <input type="checkbox"/>	Yes <input type="checkbox"/>	Yes <input type="checkbox"/>	Yes <input type="checkbox"/>	Yes <input type="checkbox"/>	Yes <input type="checkbox"/>	Yes <input type="checkbox"/>
4.7	Fit casing	Yes <input type="checkbox"/>	Yes <input type="checkbox"/>	Yes <input type="checkbox"/>	Yes <input type="checkbox"/>	Yes <input type="checkbox"/>	Yes <input type="checkbox"/>	Yes <input type="checkbox"/>	Yes <input type="checkbox"/>	Yes <input type="checkbox"/>	Yes <input type="checkbox"/>	Yes <input type="checkbox"/>	Yes <input type="checkbox"/>	Yes <input type="checkbox"/>	Yes <input type="checkbox"/>	Yes <input type="checkbox"/>
4.8	Check flue integrity	Yes <input type="checkbox"/>	Yes <input type="checkbox"/>	Yes <input type="checkbox"/>	Yes <input type="checkbox"/>	Yes <input type="checkbox"/>	Yes <input type="checkbox"/>	Yes <input type="checkbox"/>	Yes <input type="checkbox"/>	Yes <input type="checkbox"/>	Yes <input type="checkbox"/>	Yes <input type="checkbox"/>	Yes <input type="checkbox"/>	Yes <input type="checkbox"/>	Yes <input type="checkbox"/>	Yes <input type="checkbox"/>
6	Gas Safe/Benchmark documentation updated	Yes <input type="checkbox"/>	Yes <input type="checkbox"/>	Yes <input type="checkbox"/>	Yes <input type="checkbox"/>	Yes <input type="checkbox"/>	Yes <input type="checkbox"/>	Yes <input type="checkbox"/>	Yes <input type="checkbox"/>	Yes <input type="checkbox"/>	Yes <input type="checkbox"/>	Yes <input type="checkbox"/>	Yes <input type="checkbox"/>	Yes <input type="checkbox"/>	Yes <input type="checkbox"/>	Yes <input type="checkbox"/>
8	Appliance left to customer settings	Yes <input type="checkbox"/>	Yes <input type="checkbox"/>	Yes <input type="checkbox"/>	Yes <input type="checkbox"/>	Yes <input type="checkbox"/>	Yes <input type="checkbox"/>	Yes <input type="checkbox"/>	Yes <input type="checkbox"/>	Yes <input type="checkbox"/>	Yes <input type="checkbox"/>	Yes <input type="checkbox"/>	Yes <input type="checkbox"/>	Yes <input type="checkbox"/>	Yes <input type="checkbox"/>	Yes <input type="checkbox"/>
9	Gas Safe registration number	Yes <input type="checkbox"/>	Yes <input type="checkbox"/>	Yes <input type="checkbox"/>	Yes <input type="checkbox"/>	Yes <input type="checkbox"/>	Yes <input type="checkbox"/>	Yes <input type="checkbox"/>	Yes <input type="checkbox"/>	Yes <input type="checkbox"/>	Yes <input type="checkbox"/>	Yes <input type="checkbox"/>	Yes <input type="checkbox"/>	Yes <input type="checkbox"/>	Yes <input type="checkbox"/>	Yes <input type="checkbox"/>
	Gas Safe Engineers Signature															

Table 49 Inspection and maintenance checklist

SERVICE & INTERIM BOILER WORK RECORD

It is recommended that your boiler and heating system are regularly serviced and maintained, in line with manufacturers' instructions, and that the appropriate service / interim work record is completed.

Service provider

When completing a service record (as below), please ensure you have carried out the service as described in the manufacturers' instructions. Always use the manufacturers' specified spare parts.

SERVICE/INTERIM WORK ON BOILER <small>delete as appropriate</small>					Date:	
Engineer name:		Company name:				
Telephone N°:		Gas Safe registration N°:				
Max rate	CO	ppm	CO ₂	%	CO/CO ₂	
Min rate	CO	ppm	CO ₂	%	CO/CO ₂	
Where possible, has a flue integrity check been undertaken in accordance with manufacturers' instructions, and readings are correct?"					yes	
Gas rate:	m ³ /h	OR	ft ³ /h			
Were parts fitted? <small>delete as appropriate</small>	Yes	No				
Parts fitted:						
System inhibitor concentration has been checked and appropriate action taken, in accordance with BS 7593 and boiler manufacturers' instructions. *					yes	n/a
Comments:						
Signature:						

*A System inhibitor efficacy test is required on every annual service in accordance with the manufacturers' instructions and BS 7593. It is only acceptable to not have undertaken this if the service engineers attendance visit was in between annual services to attend a non-water facing component.

SERVICE/INTERIM WORK ON BOILER <small>delete as appropriate</small>					Date:	
Engineer name:		Company name:				
Telephone N°:		Gas Safe registration N°:				
Max rate	CO	ppm	CO ₂	%	CO/CO ₂	
Min rate	CO	ppm	CO ₂	%	CO/CO ₂	
Where possible, has a flue integrity check been undertaken in accordance with manufacturers' instructions, and readings are correct?"					yes	
Gas rate:	m ³ /h	OR	ft ³ /h			
Were parts fitted? <small>delete as appropriate</small>	Yes	No				
Parts fitted:						
System inhibitor concentration has been checked and appropriate action taken, in accordance with BS 7593 and boiler manufacturers' instructions. *					yes	n/a
Comments:						
Signature:						

*A System inhibitor efficacy test is required on every annual service in accordance with the manufacturers' instructions and BS 7593. It is only acceptable to not have undertaken this if the service engineers attendance visit was in between annual services to attend a non-water facing component.

SERVICE/INTERIM WORK ON BOILER <small>delete as appropriate</small>					Date:	
Engineer name:		Company name:				
Telephone N°:		Gas Safe registration N°:				
Max rate	CO	ppm	CO ₂	%	CO/CO ₂	
Min rate	CO	ppm	CO ₂	%	CO/CO ₂	
Where possible, has a flue integrity check been undertaken in accordance with manufacturers' instructions, and readings are correct?"					yes	
Gas rate:	m ³ /h	OR	ft ³ /h			
Were parts fitted? <small>delete as appropriate</small>	Yes	No				
Parts fitted:						
System inhibitor concentration has been checked and appropriate action taken, in accordance with BS 7593 and boiler manufacturers' instructions. *					yes	n/a
Comments:						
Signature:						

*A System inhibitor efficacy test is required on every annual service in accordance with the manufacturers' instructions and BS 7593. It is only acceptable to not have undertaken this if the service engineers attendance visit was in between annual services to attend a non-water facing component.

SERVICE/INTERIM WORK ON BOILER <small>delete as appropriate</small>					Date:	
Engineer name:		Company name:				
Telephone N°:		Gas Safe registration N°:				
Max rate	CO	ppm	CO ₂	%	CO/CO ₂	
Min rate	CO	ppm	CO ₂	%	CO/CO ₂	
Where possible, has a flue integrity check been undertaken in accordance with manufacturers' instructions, and readings are correct?"					yes	
Gas rate:	m ³ /h	OR	ft ³ /h			
Were parts fitted? <small>delete as appropriate</small>	Yes	No				
Parts fitted:						
System inhibitor concentration has been checked and appropriate action taken, in accordance with BS 7593 and boiler manufacturers' instructions. *					yes	n/a
Comments:						
Signature:						

*A System inhibitor efficacy test is required on every annual service in accordance with the manufacturers' instructions and BS 7593. It is only acceptable to not have undertaken this if the service engineers attendance visit was in between annual services to attend a non-water facing component.

SERVICE/INTERIM WORK ON BOILER <small>delete as appropriate</small>					Date:	
Engineer name:		Company name:				
Telephone N°:		Gas Safe registration N°:				
Max rate	CO	ppm	CO ₂	%	CO/CO ₂	
Min rate	CO	ppm	CO ₂	%	CO/CO ₂	
Where possible, has a flue integrity check been undertaken in accordance with manufacturers' instructions, and readings are correct?"					yes	
Gas rate:	m ³ /h	OR	ft ³ /h			
Were parts fitted? <small>delete as appropriate</small>	Yes	No				
Parts fitted:						
System inhibitor concentration has been checked and appropriate action taken, in accordance with BS 7593 and boiler manufacturers' instructions. *					yes	n/a
Comments:						
Signature:						

*A System inhibitor efficacy test is required on every annual service in accordance with the manufacturers' instructions and BS 7593. It is only acceptable to not have undertaken this if the service engineers attendance visit was in between annual services to attend a non-water facing component.

SERVICE/INTERIM WORK ON BOILER <small>delete as appropriate</small>					Date:	
Engineer name:		Company name:				
Telephone N°:		Gas Safe registration N°:				
Max rate	CO	ppm	CO ₂	%	CO/CO ₂	
Min rate	CO	ppm	CO ₂	%	CO/CO ₂	
Where possible, has a flue integrity check been undertaken in accordance with manufacturers' instructions, and readings are correct?"					yes	
Gas rate:	m ³ /h	OR	ft ³ /h			
Were parts fitted? <small>delete as appropriate</small>	Yes	No				
Parts fitted:						
System inhibitor concentration has been checked and appropriate action taken, in accordance with BS 7593 and boiler manufacturers' instructions. *					yes	n/a
Comments:						
Signature:						

*A System inhibitor efficacy test is required on every annual service in accordance with the manufacturers' instructions and BS 7593. It is only acceptable to not have undertaken this if the service engineers attendance visit was in between annual services to attend a non-water facing component.

* All installations in England and Wales must be notified to Local Authority Building Control (LABC) either directly or through a Competent Persons Scheme. A Building Regulations Compliance Certificate will then be issued to the customer.

SERVICE & INTERIM BOILER WORK RECORD

It is recommended that your boiler and heating system are regularly serviced and maintained, in line with manufacturers' instructions, and that the appropriate service / interim work record is completed.

Service provider

When completing a service record (as below), please ensure you have carried out the service as described in the manufacturers' instructions. Always use the manufacturers' specified spare parts.

SERVICE/INTERIM WORK ON BOILER <small>delete as appropriate</small>					Date:	
Engineer name:		Company name:				
Telephone N°:		Gas Safe registration N°:				
Max rate	CO	ppm	CO ₂	%	CO/CO ₂	
Min rate	CO	ppm	CO ₂	%	CO/CO ₂	
Where possible, has a flue integrity check been undertaken in accordance with manufacturers' instructions, and readings are correct?"					yes	
Gas rate:	m ³ /h	OR	ft ³ /h			
Were parts fitted? <small>delete as appropriate</small>	Yes	No				
Parts fitted:						
System inhibitor concentration has been checked and appropriate action taken, in accordance with BS 7593 and boiler manufacturers' instructions. *					yes	n/a
Comments:						
Signature:						

*A System inhibitor efficacy test is required on every annual service in accordance with the manufacturers' instructions and BS 7593. It is only acceptable to not have undertaken this if the service engineers attendance visit was in between annual services to attend a non-water facing component.

SERVICE/INTERIM WORK ON BOILER <small>delete as appropriate</small>					Date:	
Engineer name:		Company name:				
Telephone N°:		Gas Safe registration N°:				
Max rate	CO	ppm	CO ₂	%	CO/CO ₂	
Min rate	CO	ppm	CO ₂	%	CO/CO ₂	
Where possible, has a flue integrity check been undertaken in accordance with manufacturers' instructions, and readings are correct?"					yes	
Gas rate:	m ³ /h	OR	ft ³ /h			
Were parts fitted? <small>delete as appropriate</small>	Yes	No				
Parts fitted:						
System inhibitor concentration has been checked and appropriate action taken, in accordance with BS 7593 and boiler manufacturers' instructions. *					yes	n/a
Comments:						
Signature:						

*A System inhibitor efficacy test is required on every annual service in accordance with the manufacturers' instructions and BS 7593. It is only acceptable to not have undertaken this if the service engineers attendance visit was in between annual services to attend a non-water facing component.

SERVICE/INTERIM WORK ON BOILER <small>delete as appropriate</small>					Date:	
Engineer name:		Company name:				
Telephone N°:		Gas Safe registration N°:				
Max rate	CO	ppm	CO ₂	%	CO/CO ₂	
Min rate	CO	ppm	CO ₂	%	CO/CO ₂	
Where possible, has a flue integrity check been undertaken in accordance with manufacturers' instructions, and readings are correct?"					yes	
Gas rate:	m ³ /h	OR	ft ³ /h			
Were parts fitted? <small>delete as appropriate</small>	Yes	No				
Parts fitted:						
System inhibitor concentration has been checked and appropriate action taken, in accordance with BS 7593 and boiler manufacturers' instructions. *					yes	n/a
Comments:						
Signature:						

*A System inhibitor efficacy test is required on every annual service in accordance with the manufacturers' instructions and BS 7593. It is only acceptable to not have undertaken this if the service engineers attendance visit was in between annual services to attend a non-water facing component.

SERVICE/INTERIM WORK ON BOILER <small>delete as appropriate</small>					Date:	
Engineer name:		Company name:				
Telephone N°:		Gas Safe registration N°:				
Max rate	CO	ppm	CO ₂	%	CO/CO ₂	
Min rate	CO	ppm	CO ₂	%	CO/CO ₂	
Where possible, has a flue integrity check been undertaken in accordance with manufacturers' instructions, and readings are correct?"					yes	
Gas rate:	m ³ /h	OR	ft ³ /h			
Were parts fitted? <small>delete as appropriate</small>	Yes	No				
Parts fitted:						
System inhibitor concentration has been checked and appropriate action taken, in accordance with BS 7593 and boiler manufacturers' instructions. *					yes	n/a
Comments:						
Signature:						

*A System inhibitor efficacy test is required on every annual service in accordance with the manufacturers' instructions and BS 7593. It is only acceptable to not have undertaken this if the service engineers attendance visit was in between annual services to attend a non-water facing component.

SERVICE/INTERIM WORK ON BOILER <small>delete as appropriate</small>					Date:	
Engineer name:		Company name:				
Telephone N°:		Gas Safe registration N°:				
Max rate	CO	ppm	CO ₂	%	CO/CO ₂	
Min rate	CO	ppm	CO ₂	%	CO/CO ₂	
Where possible, has a flue integrity check been undertaken in accordance with manufacturers' instructions, and readings are correct?"					yes	
Gas rate:	m ³ /h	OR	ft ³ /h			
Were parts fitted? <small>delete as appropriate</small>	Yes	No				
Parts fitted:						
System inhibitor concentration has been checked and appropriate action taken, in accordance with BS 7593 and boiler manufacturers' instructions. *					yes	n/a
Comments:						
Signature:						

*A System inhibitor efficacy test is required on every annual service in accordance with the manufacturers' instructions and BS 7593. It is only acceptable to not have undertaken this if the service engineers attendance visit was in between annual services to attend a non-water facing component.

SERVICE/INTERIM WORK ON BOILER <small>delete as appropriate</small>					Date:	
Engineer name:		Company name:				
Telephone N°:		Gas Safe registration N°:				
Max rate	CO	ppm	CO ₂	%	CO/CO ₂	
Min rate	CO	ppm	CO ₂	%	CO/CO ₂	
Where possible, has a flue integrity check been undertaken in accordance with manufacturers' instructions, and readings are correct?"					yes	
Gas rate:	m ³ /h	OR	ft ³ /h			
Were parts fitted? <small>delete as appropriate</small>	Yes	No				
Parts fitted:						
System inhibitor concentration has been checked and appropriate action taken, in accordance with BS 7593 and boiler manufacturers' instructions. *					yes	n/a
Comments:						
Signature:						

*A System inhibitor efficacy test is required on every annual service in accordance with the manufacturers' instructions and BS 7593. It is only acceptable to not have undertaken this if the service engineers attendance visit was in between annual services to attend a non-water facing component.

* All installations in England and Wales must be notified to Local Authority Building Control (LABC) either directly or through a Competent Persons Scheme. A Building Regulations Compliance Certificate will then be issued to the customer.

14 Data Protection Notice



We, **Bosch Thermotechnology Ltd., Cotswold Way, Warndon, Worcester WR4 9SW, United Kingdom**

process product and installation information, technical and connection data, communication data, product registration and client history data to provide product functionality (art. 6 (1) sentence 1 (b) GDPR

/ UK GDPR), to fulfil our duty of product surveillance and for product safety and security reasons (art. 6 (1) sentence 1 (f) GDPR / UK GDPR), to safeguard our rights in connection with warranty and product registration questions (art. 6 (1) sentence 1 (f) GDPR / UK GDPR) and to analyze the distribution of our products and to provide individualized information and offers related to the product (art. 6 (1) sentence 1 (f) GDPR / UK GDPR). To provide services such as sales and marketing services, contract management, payment handling, programming, data hosting and hotline services we can commission and transfer data to external service providers and/or Bosch affiliated enterprises. In some cases, but only if appropriate data protection is ensured, personal data might be transferred to recipients located outside of the European Economic Area and the United Kingdom. Further information are provided on request. You can contact our Data Protection Officer under: Data Protection Officer, Information Security and Privacy (C/ISP), Robert Bosch GmbH, Postfach 30 02 20, 70442 Stuttgart, GERMANY.

You have the right to object, on grounds relating to your particular situation or where personal data are processed for direct marketing purposes, at any time to processing of your personal data which is based on art. 6 (1) sentence 1 (f) GDPR / UK GDPR. To exercise your rights, please contact us via privacy.ttg@bosch.com To find further information, please follow the QR-Code.



TECHNICAL SUPPORT: 0330 123 3366
RENEWABLE SUPPORT: 0330 123 9229
CONTROLS AND CONNECTIVITY TEAM: 0330 123 3641
APPOINTMENTS: 0330 123 9339
SPARES: 0330 123 9779
LITERATURE: 0330 123 9119
TRAINING: 0330 123 0166
SALES: 0330 123 9669

Bosch Thermotechnology Ltd.
Cotswold Way, Warndon
Worcester WR4 9SW
United Kingdom
Tel. 0330 123 9559
worcester-bosch.co.uk

