

Installation & Maintenance Instructions
Single & Twin Coil Unvented Cylinders:
Indirect, Solar Indirect & Heat Pump

Green Storage Cylinders

90/120/150/180/210/250/300 litre

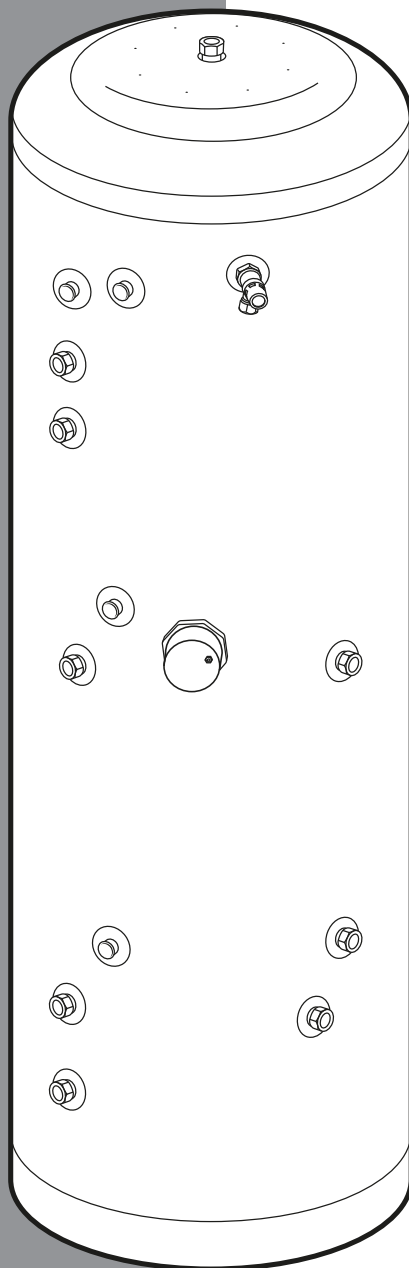

Part No: 1051705 - ISSUED AUGUST 2021 - V1



WB RANGE

CONTENTS

3	Your cylinder and its components
3	Preparing to install the cylinder
4 - 7	Installation instructions
8	Product specification details
9	Product diagrams, connections & measurements
10 - 11	Fiche Data & Parts List
12 - 13	Fitting with Greenstar system boilers with optional internal diverter valves
13 - 17	Schematic wiring diagrams
18	Commissioning and decommissioning
19	Servicing instructions and fault-finding
20	Information for homeowners
21	Benchmark Commissioning Checklist
22	Service record
23 - 24	Guarantee and product registration

INTRODUCTION

These cylinders are manufactured to the highest specification standards with superior product engineering, materials and stringent production processes, to deliver the highest quality products.

When installed and maintained in accordance with this manual, the cylinders will reliably store and generate hot water for years to come. The manual details how to prepare, install, commission, service and decommission the cylinders. It covers both indirect, solar and heat pump models with an external thermal expansion vessel. A separate insert sheet contains specific technical details for your chosen hot water cylinder.

As well as comprehensive instructions for installers, the manual provides guidance and guarantee information for homeowners.

WORCESTER BOSCH CONTACT INFORMATION

TECHNICAL SUPPORT:	0330 123 3366
CONTROLS & CONNECTIVITY TEAM:	0330 123 3641
APPOINTMENTS:	0330 123 9339
SPARES:	0330 123 9779
LITERATURE:	0330 123 9119
TRAINING:	0330 123 0166
SALES:	0330 123 9669



THE BENCHMARK CODE DEMONSTRATING COMPLIANCE, REASSURING HOMEOWNERS

Benchmark places responsibilities on both the manufacturer and installer. The purpose is to ensure that customers are provided with the correct equipment for their needs, that the equipment is installed, commissioned and serviced in accordance with the manufacturer's instructions by competent persons and that it meets the requirements of the appropriate Building Regulations. The Benchmark Checklist can be used to demonstrate compliance with Building Regulations and should be provided to the customer for future reference.

Installers are required to carry out installation, commissioning and servicing work in accordance with the Benchmark Code of Practice which is available from the Heating and Hotwater Industry Council who manage and promote the Scheme. Visit www.centralheating.co.uk for more information.



We are a Charter Members of the Hot Water Association and undertake to meet the requirements of the Charter Scheme: To supply fit for purpose products clearly and honestly described. To supply products that meet or exceed appropriate standards and building and water regulations. To provide pre- and post-technical support.

To provide a clear and concise warranty details to customers. For further details on the Charter, please visit www.hotwater.org.uk/hwa-charter



IMPORTANT NOTE TO THE INSTALLER

Read these instructions before commencing installation. Unvented cylinders are a controlled service as defined in the latest edition of the building regulations and should only be fitted by a competent person.

You must ensure the installation complies with the current Building Regulations and or Technical Standards Documents for England, Scotland, Wales, N Ireland or Ireland.

After installation the Benchmark Commissioning Checklist on page 21 must be completed and left, with these instructions, with the householder for future reference.



IMPORTANT NOTE TO THE HOMEOWNER

Please ensure that the installer has fully completed the Benchmark Commissioning Checklist on page 21 of this installation manual. You will need this information should you need to make a claim against your product guarantee in the future.

This product requires servicing every 12 months and the Service Record must be maintained to protect your 25-year guarantee (10 years on heat pump models).

Please note all images are for illustrative purposes only and specific products will vary for each product line.

YOUR CYLINDER AND ITS COMPONENTS

YOUR CYLINDER AND ITS COMPONENTS

The unvented cylinder comes complete with the necessary fittings, safety and control devices needed to connect to the cold water mains. All have been pre-adjusted. High quality controls have been selected to combine high flow rate performance with minimum pressure drop to make the unvented cylinder perform well in all areas, even those with poor water pressure. See insert sheet for a list of spare parts.

SUPPLIED COMPONENTS

All indirect models are supplied with installation and maintenance instructions, technical performance & specification data fiche, an inlet control set, a temperature and pressure relief valve, an acetel tundish and an external expansion vessel, immersion heater, dual Thermostat, two-port motorised valve.

In addition to the above solar indirect (twin coil) models also include a single high limit thermostat and a sensor pocket retaining bung.

Note: If the water quality is aggressive or the cylinder is to be used on a system with a heat pump that struggles to achieve the set temperature, we recommend exchanging the immersion heater for a titanium element.

PREPARING TO INSTALL THE CYLINDER

STORAGE PRIOR TO INSTALLATION

The unvented cylinder should be stored in its original packaging in an upright position in an area free from excessive moisture.

HANDLING PRODUCT

The unvented cylinder should be carried upright where possible. Assessments of risks for carrying the cylinder should be conducted. Use more than one person for carrying where appropriate. Always follow latest guidelines for lifting techniques, to avoid injury, or damage to the product.

WATER SUPPLY

The unvented cylinder operates at 3 bar (controlled by the inlet control set) and is capable of delivering over 50 litres per minute. The high quality inlet control set has been designed to make the most of the flow rates available, however the performance of any unvented system is only as good as the mains water supply. The maximum possible water demand should be assessed, taking into consideration that both hot and cold services are supplied simultaneously from the mains.

The water supply should be checked to ensure it can meet these requirements. If necessary, consult the local water company regarding the likely pressure and flow rate availability.

If measuring the water pressure, note that a high static (no flow) mains pressure is no guarantee of good flow availability. In a domestic installation 1.5 bar and 25 l/min. should be regarded as the minimum. The maximum mains pressure that the inlet control set can accept is 12 bar.

Consideration should be given to upgrading existing 1/2" (15mm) cold mains pipework to a larger size if the recommended minimum pressure/flow rate is not being achieved.

ELECTRICITY SUPPLY

The unvented cylinder requires 230V 50Hz electrical supply for the immersion elements. The electrical supply to each immersion heater must be fused at 13A via a double pole isolating switch that meets the current BS Standards. The cable must be at least 2.5mm² heat resistant (85°C HOFER) sheathed flex complying to the current BS Standards.

SITING THE UNIT

The unvented cylinder can supply outlets above it or at some distance from it. Site the unit to minimise "dead leg" distances, especially to the point of most frequent use. Outlets above the unvented cylinder will reduce the outlet pressure available by 0.1 bar for every 1m of height difference. The unit should be protected from frost. Particular care is needed if siting in a garage, outbuilding or loft space. All exposed pipework should be insulated. The unvented cylinder must be installed in the correct orientation i.e. vertically, on a flat base capable of supporting the weight of the cylinder when full. See technical specification insert sheet for weights. The minimum recommended cupboard size for vertical models is 750mm square.

Access

Consideration should be given to the position of discharge pipework (tundish) and drain valves. Avoid positioning these too close to electrical devices and components. Also allow sufficient space so that the cylinder can be inspected, maintained and serviced in the future.

The immersion heaters are 400mm long and care should be taken to ensure that they can be withdrawn, enabling the immersion heater to be replaced at the end of its working life and providing inspection access to the interior of the cylinder during servicing if required.

The discharge pipework from the safety valves should fall continuously and terminate safely.

INSTALLATION INSTRUCTIONS

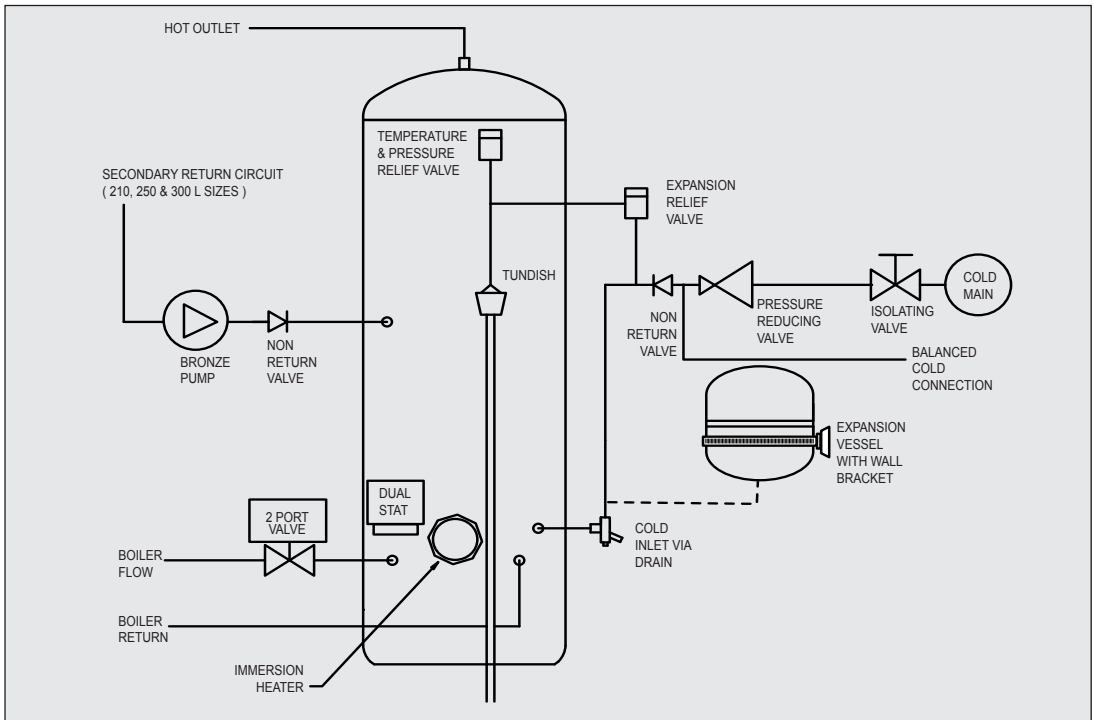

Notes:
The pressure reducing valve, non-return valve and expansion relief valve are combined together in the inlet control set.

On 120 – 180 litre sizes there is no dedicated secondary return boss and the secondary return circuit should be tee'd into the cold feed pipe just above the drain elbow.

Coil connections for heat pump models are positioned vertically, with the top connection for heat pump flow and the bottom connection for heat pump return.

COLD MAINS PIPEWORK

Run the cold mains through the building to the place where the unvented cylinder is to be installed. Take care not to run the cold pipe near hot water or heating pipework so that the heat pick-up is minimised. Identify the cold water supply pipe and fit an isolating valve (not supplied).

We recommend using a full bore 22mm quarter turn ball valve, alternatively a 22mm stopcock can be used, however this may reduce the flow rate. **Do not** use a "screwdriver slot" or similar service valve.

Make the connection to the cold feed of the cylinder and incorporate a drain valve. Position the drain valve no higher than the cold inlet to ensure sufficient draining of the cylinder when required. Position the inlet control just **above** the Temperature & Pressure Relief Valve (TPRV) mounted on the side of the cylinder. This ensures that the cylinder does not have to be drained down in order to service the inlet control set. Ensure that the arrow points in the direction of the water flow.

Select a suitable position for the expansion vessel. Mount it to the wall using the bracket attached to the vessel. Use suitable fittings capable of supporting full vessel weight (and with appropriate consideration to wall material). Connect the expansion vessel to the cold feed pipework between the inlet control set and the cold inlet on the cylinder. Ensure that the top of the vessel is accessible for servicing.

Connecting to the cylinder

All of the pipework connections on the cylinder are 22mm compression and supplied complete with gland nuts and olives, in the Accessory Kit box. Only connect 22mm BS EN1057-R250 copper tube to these connections.

Cut the tube square using a rotary tube cutter and ensure no sharp edges or burrs protrude. Slide both gland nut and olive onto the tube and push tube fully home into the connection, ensuring the tube end fully bottoms on the connection recess. Smear

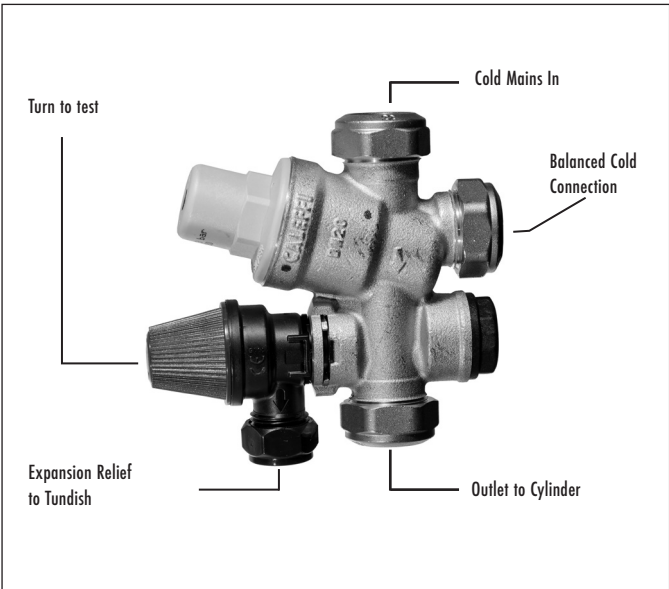

the outer wall of the olive with plumbing paste and tighten the gland nut in the prescribed manner. Upon filling/commissioning, ensure all connections are completely watertight, including immersion bosses and any pre-plumbed pipework if applicable.

Note: No control or isolation valve should be fitted between the expansion relief valve and the storage cylinder. The relief valve connections should not be used for any other purpose.

INSTALLATION INSTRUCTIONS (CONTINUED)

BALANCED HOT & COLD SUPPLY

The installer must safeguard the hot water system from back flow by ensuring the hot and cold supply to all outlet locations are balanced. All mixer: taps, showers or valve shall be installed to comply with the Water Supply (Water Fittings) Regulations 1999. If these devices have un-balanced supplies there must be single check valves installed at both inlets, to stop over-pressurisation of either supply. Note the inlet control set provided with this cylinder features a balanced cold connection, to facilitate the installation of balanced supply.

HOT WATER PIPEWORK

Run the first part of the hot water distribution pipework in 22mm. This can be reduced near to the outlet to 15mm or 10mm if appropriate, for example to suit the type of tap. You should aim to keep the run length of any hot water pipework from the cylinder to outlet to a practical minimum so the time taken for the hot water to reach the outlet is as quick as possible.

Then connect the hot water pipework to the hot water draw-off on the cylinder (Position B in the diagrams on pages 9).

CONNECTIONS FOR INDIRECT UNITS

For Solar input models refer to the shaded box before making any connections.

Connect the primary connections using the compression connections provided. The primary circuit must be positively pumped. Gravity circulation is not suitable. For heat pump coils use the top primary connection as the primary flow, reheat times will be effected if connecting the flow to the opposite end of the coil.

Either primary connection may be used as the primary flow, reheat times are not affected. The primary circuit can be open vented or sealed, up to a maximum pressure of 3.5 bar. If you seal the primary circuit an additional expansion vessel and safety valve is required.

Connect the two port valve into the primary flow pipework. The direction of the flow arrow should be towards the primary flow connection.

Where connecting to a boiler, the boiler can be Gas, Electric or Oil, but must be under effective thermostatic control. Uncontrolled heat sources such as some AGAs, back boilers, solid fuel stoves, etc. are not suitable. Please contact our Technical department for guidance.

Consult the boiler manufacturer's instructions to confirm sizing is suitable for the heating system and guidance on positioning.

SOLAR INDIRECT UNVENTED (TWIN COIL)

Upper coil

The upper coil is connected to the fossil fuel boiler as per the instructions for the unvented indirect single coil model, with the dual stat control and high limit thermostat inserted into pocket G2 (boiler). The wiring requirements are shown on page 13/17

Lower coil: solar installation

The flow and return from the solar heat source are to be connected to the bottom coil. Either primary coil connection may be utilised as the flow or return. The solar primary circuit must have its own dedicated circulating pump, thermal and safety controls, which must be installed as per the solar manufacturer's instructions. The solar control system used must be of the solar differential control type and should be connected to the solar sensor.

The solar sensor, supplied as part of the solar controls should be inserted into Pocket G1 (boiler) and is held in-situ with the black sensor pocket retaining bung provided.

It is necessary to connect the solar pump via the overtemperature high limit cut-out (provided) to ensure the heat input to the solar coil is interrupted if the cylinder overheats. Some method to prevent thermosyphoning must also be employed. Non-return check valves in the primary flow and return pipework would be acceptable. If solar controls do not offer appropriate isolation, a two port zone valve (not supplied) can be used with the pump and high limit stat as shown on page 14/15.

Note:

If it is intended to fit a cylinder with a solar coil to be used at a later date, the two coils should be connected in series to make use of the solar coil, using the dual stat in Pocket G2 (boiler) or Pocket G1 (Solar), as shown in the diagram on page 9.

The Domestic Heating Compliance Guide document L1A and L1B provides excellent advice in sizing both cylinder dedicated solar areas and heat exchangers to the surface area of the solar collectors. Using this guide we are able to offer sizing advice for specification.

Note:

Consult all details of the compliance guide documentation prior to specifying product or commencing design.

INSTALLATION INSTRUCTIONS (CONTINUED)

SECONDARY CIRCULATION CONNECTION

This can be used with secondary circulation. An appropriate WRAS approved bronze or stainless steel circulator should be used in conjunction with a non-return valve to prevent backflow.

On large secondary circulation systems it may be necessary to incorporate an extra expansion vessel into the circuit to accommodate the increased system water volume.

A secondary return boss is fitted as standard on 210, 250 & 300 ltr units. On smaller sizes, use a swept tee to connect into the cold feed pipe above the drain.

IMMERSION HEATERS

Only immersion heaters with a thermal cut-out that comply with BS EN 60335-2-73 may be used. To help ensure this, the immersion heaters have a special 1 3/4" thread. They are rated at 3kW at 240V and are of a low noise incoloy construction.

They have both a thermostat and a high limit cut-out. Please order the correct replacement via ourselves; fitting non-approved immersions may affect your guarantee. When fitting, ensure the 'O' ring is positioned correctly on the head of the immersion heater and lubricate before fitting. Fit it by hand until almost home then tighten gently, as the 'O' rings will seal easily. Electrical supply refer to page 3.

Do not operate the immersion heater/s until the cylinder is full of water.

Do not operate the immersion heater/s if any sterilisation liquid is in the cylinder as this will cause premature failure.

If the water quality is aggressive or the cylinder is to be used on a system with a heat pump that struggles to achieve the set temperature, we recommend exchanging the immersion heater for a titanium element.

Note: Immersion heaters should never be used as the primary heat source.

ELECTRICAL CONNECTIONS

Complete the wiring – use the appropriate wiring diagrams on pages 13-17.

DISCHARGE ARRANGEMENT

You will need to position the inlet control group so that the discharge from both safety valves can be joined together via a 15mm tee (see diagram below). Connect the tundish and then connect and route the discharge pipe.

Ensure all pipes to and from the tundish are cut square, are free from burrs or damage, and that the tundish is fitted vertically.

The discharge pipework must be routed in accordance with Part G3 of schedule 1 of the Building Regulations. The information that follows is not exhaustive and if you are in doubt you should seek advice.

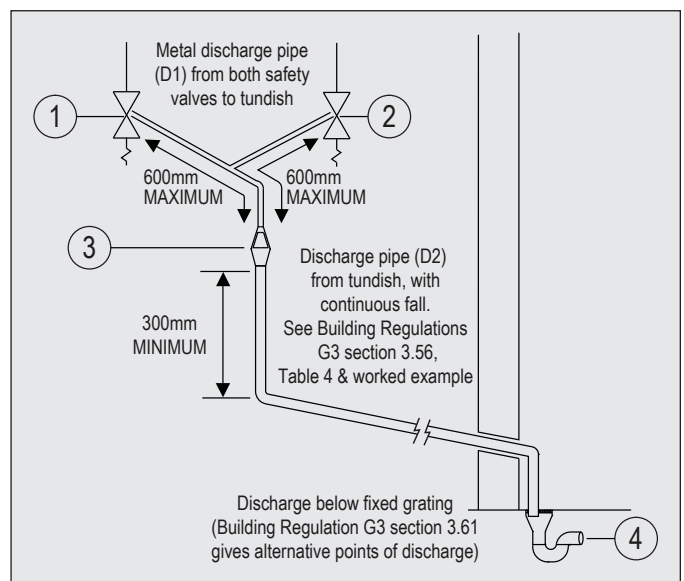

- 1) Expansion relief valve on inlet control set
- 2) Temperature & pressure relief valve on cylinder
- 3) Tundish

Note: The discharge will consist of scalding water and steam. Asphalt, roofing felt and non-metallic rainwater goods may be damaged by such discharges.

Note: Although Building Regulations now permit the D2 pipe from the tundish to be installed in soil stacks within premises, we do not recommend this, as discharge from the temperature and pressure valve may continue for long periods of time. It is the installer's responsibility to ensure the discharge pipework can support the discharge for prolonged periods. If used, follow the guidance given in the G3 Building Regulations (mechanical seal without water trap). As discharge can be in excess of 90°C, discharge into plastic pipework is also not recommended.

INSTALLATION INSTRUCTIONS (CONTINUED)

The two safety valves will only discharge water under fault conditions. When operating normally water will not be discharged. The tundish should be located in the same space as the unvented hot water storage system and be fitted as close as possible to, and lower than, the safety device, with no more than 600mm of pipe between the valve outlet and the tundish. The tundish should be positioned away from electrical devices.

The tundish should be located in a position so that any discharge is visible. In addition, where discharges from safety devices may not be apparent, extra consideration should be given, e.g. for people with impaired vision or mobility. This could be via the installation of a suitable electronically operated or other safety device to warn when discharge takes place.

The discharge pipe (D2) from the tundish should:

- A) Have a vertical section of pipe at least 300mm long, below the tundish before any elbows or bends in the pipework.
- B) Be installed with a continuous fall of at least 1 in 200 thereafter.

The discharge pipe (D2) from the tundish should be of metal or other material that has been demonstrated to be capable of withstanding temperatures of the water discharged.

The discharge pipe (D2) should be at least one pipe size larger than the nominal outlet size of the safety device, unless its total equivalent hydraulic resistance exceeds that of a straight pipe 9m long. Therefore, discharge pipes between 9m and 18m equivalent resistance length should be at least two sizes larger than the nominal outlet size of the safety device; between 18 and 27m at least three sizes larger. Bends must be taken into account in calculating the flow resistance. Refer to the diagram, Table 2 and the worked example.

An alternative approach for sizing discharge pipes would be to follow BS EN 806:2 specifications for design, installation, testing and maintenance of services supplying water for domestic use within buildings and their curtilages.

The discharge pipe (D2) should terminate in a safe place where there is no risk to persons in the vicinity of the discharge. Examples of acceptable discharge arrangements are:

A) To a trapped gully with the end of the pipe below the fixed grating and above the water seal.

B) Downward discharges at a low level; i.e. up to 100mm above external surfaces such as car parks, hard standings, grassed areas etc. are acceptable, providing that – where children play or otherwise could come into contact with discharges – a visible wire cage or similar guard is positioned to prevent contact.

C) Discharges at a high level; e.g. into a metal hopper and metal down pipe with the end of the discharge pipe clearly visible; or onto a roof capable of withstanding high temperature discharges of water and 3m from any plastic guttering systems that would collect such discharges.

D) Device to warn when discharge takes place.

Discharge worked example

The example below is for G1/2 temperature relief valve with a discharge pipe (D2) having four elbows and a length of 7m from the tundish to the point of discharge.

Maximum resistance allowed for a straight length of 22mm copper discharge pipe (D2) from a G1/2 temperature relief valve is: 9.0m.

Subtract the resistance for four 22mm elbows at 0.8m each = 3.2m.

Therefore the maximum permitted length equates to: 5.8m.

5.8m is less than the actual length of 7m, therefore calculate the next largest size.

Maximum resistance allowed for a straight length of 28mm pipe (D2) from a G1/2 temperature relief valve equates to: 14m.

As the actual length is 7m, a 28mm (D2) copper pipe will be satisfactory.

Table 2: Sizing of copper discharge pipe 'D2' for a temperature relief valve with a G1/2 outlet size (as supplied).

Size of discharge pipework	Maximum length of straight pipe (no bends or elbows)	Deduct the figure below from the maximum length for each bend or elbow in the discharge pipe
22mm	Up to 9m	0.8m
28mm	Up to 18m	1.0m
35mm	Up to 27m	1.4m

SPECIFICATION DETAILS

The unvented cylinder is made from Duplex stainless steel for excellent corrosion resistance. The cylinder has a strong rust-proofed steel case and is highly insulated with environmentally-friendly foam. Further details are below.

MATERIALS

- Inner shell – Duplex stainless steel
- Coil – 22mm diameter stainless steel
- Bosses – Stainless steel
- Polyurethane CFC- and HCFC-free foam insulation. This insulation has an Ozone Depletion Potential of Zero and a Global Warming Potential of 3.1.
- Casing – galvanized steel, durable finish
- Anode – none fitted/required

All cylinders are welded using our advanced welding production methods, under a controlled oxygen purged process, to maximize the corrosion resistant qualities of the high-grade Duplex stainless steel. Every cylinder is checked using 15 bar pressure testing.

IMMERSION HEATER

- 1¼" BSP parallel threaded head
- Long life incoloy sheathed low noise element and thermostat pocket
- Brazed construction
- Combined thermostat and safety cut-out
- Element rating 3kW at 230V A/C

FLOW RATES

Our cylinders are renowned for their fast flow rates. The graph illustrates the speed at which hot water can be distributed reliably throughout the home.

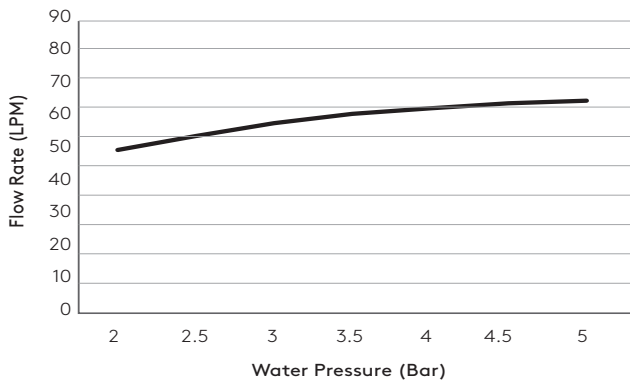

Table 3: Pressure specifications

Maximum Inlet Water Pressure	12.0 bar
Operating Pressure/Maximum Design Pressure	3.0 bar
Expansion Valve Opening Pressure	6.0 bar
Expansion Vessel Charge Pressure	3.0 bar
Maximum Operating Pressure	7.0 bar
Opening Pressure of T & P Valve	7.0 bar
Opening Temperature of T & P Valve	90 °C
Maximum Pressure on Primary Circuit (Indirect/Solar/Heat Pump Coil)	3.5 bar

Table 4: Immersion element specifications

Element Rating	3kW 230V
Thread Type	1¼" BSP
Fuse Requirement	13A via Double Pole Switch
Control Thermostat for Element Temperature Range	45 °C - 65 °C
High Limit Thermostat for Element Temperature Set Point	85 °C

PRODUCT DIAGRAMS

INDIRECT

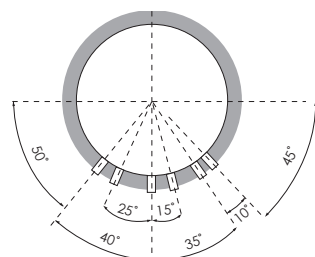
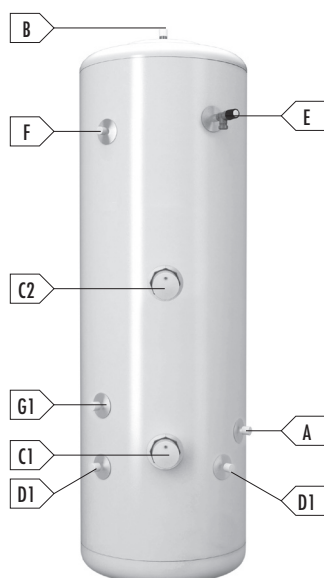

HEAT PUMP

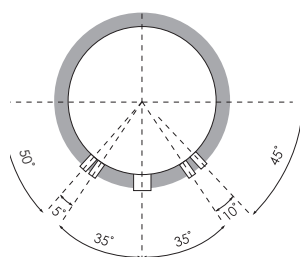
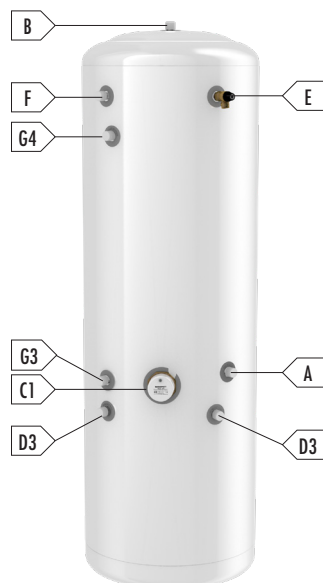

SOLAR INDIRECT

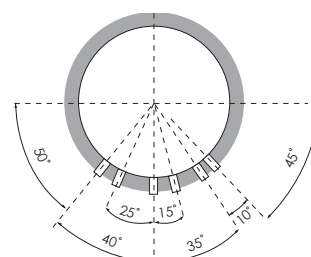
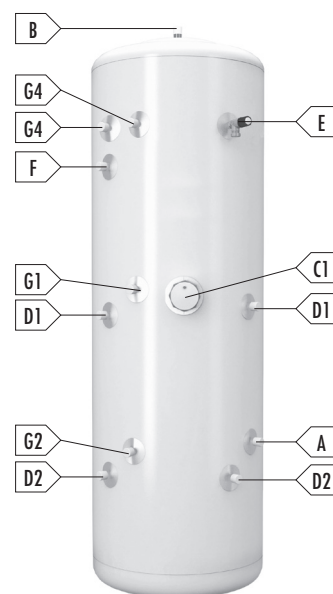

CONNECTIONS:

- A** 22mm Cold feed with dip pipe to diffuser in bottom of cylinder
- B** 22mm Hot water outlet
- C1** 1 3/4" Immersion heater (factory-fitted to cylinder)
- C2** 1 3/4" Secondary immersion heater (250 litre & above only)
- D1** 22mm Boiler coil connections
- D2** 22mm Solar coil connections
- D3** 22mm Heat pump coil connections
- E** 1/2" Temperature & pressure relief valve (factory-fitted to cylinder)
- F** 22mm Secondary return (for cylinders with a capacity of 210 litres and above only)
- G1** 20mm Dry stat pocket (boiler)
- G2** 20mm Dry stat pocket (solar)
- G3** 20mm Dry stat pocket (heat pump)
- G4** 20mm Dry stat pocket (high limit/ TW1 sensor)

TECHNICAL PERFORMANCE AND SPECIFICATION DATA - FICHE

Nominal Capacity (Litre)	Product Codes Worcester Bosch / OMC	Energy Rating	Standing Loss (W)	Total Height (mm)	Weight Empty (kg)	Weight Full (kg)	Actual Capacity (Litre)
Indirect unvented hot water cylinders							
90	7-733-601-298 / GSSC90ERP	C	49	761	30	117.9	87.9
120	7-733-601-299 / GSSC120ERP	C	54	933	35	155.1	120.1
150	7-733-601-300 / GSSC150ERP	C	59	1120	35	185.4	150.4
180	7-733-601-301 / GSSC180ERP	C	67	1308	45	225.6	180.6
210	7-733-601-302 / GSSC210ERP	C	75	1496	50	260.6	210.6
250	7-733-601-303 / GSSC250ERP	C	84	1746	55	305.9	250.9
300	7-733-601-304 / GSSC300ERP	C	93	2059	60	360.3	300.3
Heat pump unvented hot water cylinders							
150	7-733-601-189 / GSHP150ERP	C	59	1120	45	195.0	150.0
180	7-733-601-333 / GSHP180ERP	C	67	1308	50	230.0	180.0
210	7-733-601-334 / GSHP210ERP	C	75	1496	54	264.0	210.0
250	7-733-601-335 / GSHP250ERP	C	84	1746	62	306.0	250.0
300	7-733-601-336 / GSHP300ERP	C	93	2059	68	368.0	300.0
Solar twin coil unvented hot water cylinders							
180	7-733-601-306 / GSTC180ERP	C	67	1308	60	228.0	178.0
210	7-733-601-307 / GSTC210ERP	C	75	1496	65	259.6	204.6
250	7-733-601-308 / GSTC250ERP	C	84	1746	70	307.0	247.0
300	7-733-601-309 / GSTC300ERP	C	93	2059	75	360.6	295.6

PARTS LIST



Installation and maintenance instructions

Spare part no: 8-716-121-839
Download www.worcester-bosch.co.uk



Inlet control set – with balanced Cold

3 bar PRV 6 bar expansion relief
Spare part no: 8-716-121-840



Temperature & pressure relief valve

1/2" NPT x 15mm
Spare part No: 8-716-121-841



Anti splash tundish

15 x 22 mm
Spare part no: 8-716-121-842



External expansion vessel - DHW

Units 250L & under - 18 litre vessel
Spare part no: 8-716-121-843

300L units - 25 litre vessel
Spare part no: 8-716-121-844

Heat-up Time (Minutes)	Heat Loss (kW/24Hr)	Pressure Drop (Bar)	Product specifics		
			Indirect Coil Surface Area (m ²)	Indirect Coil Capacity (Litre)	Indirect Coil (kW Rating)
18.18	1.18	0.16	0.67	3.69	17.98
23.85	1.29	0.14	0.67	3.69	18.49
27.00	1.41	0.16	0.77	4.22	19.72
32.50	1.61	0.15	0.77	4.22	20.17
35.15	1.79	0.17	0.86	4.75	21.35
40.62	2.02	0.17	0.86	4.75	22.40
51.77	2.24	0.16	0.86	4.75	21.43
			Indirect Coil Surface Area (m ²)	Indirect Coil Capacity (Litre)	Indirect Coil (kW Rating)
N/A*	1.41	0.08	2.3	14.5	32.0
N/A*	1.61	0.08	2.3	14.5	32.0
N/A*	1.79	0.08	2.3	14.5	32.0
N/A*	2.02	0.08	2.3	14.5	32.0
N/A*	2.24	0.08	2.3	14.5	34.0

All Cylinders

3 Bar
Max design pressure (DHW)

Insulation Thickness
50 mm

Recommended
60°
Stored Water
Temperature

3.5 Bar
Max primary coil pressure

Recommended Minimum Input
25 L.P.M.
@
1.5 Bar



BS EN 12897:2016+A1:2020
Water supply. Specification for indirectly heated unvented (closed) storage water heaters.

			Dedicated Solar Volume (Litre)	Solar Coil Surface Area (m ²)	Solar Coil Capacity (Litre)	Solar Coil (kW Rating)	Indirect Coil Surface Area (m ²)	Indirect Coil Capacity (Litre)
35.75	1.61	0.15	53.6	0.67	3.69	18.48	0.67	3.69
35.42	1.79	0.17	51.8	0.77	4.22	19.75	0.77	4.25
40.50	2.02	0.17	92.2	0.77	4.22	20.68	0.77	4.25
48.38	2.24	0.16	79.3	0.86	4.75	22.08	0.86	4.75

PARTS LIST



Two port valve
Spare Part No: 8-716-121-848



Dual thermostat
Spare part nos: 8-716-121-847



Immersion heater
Incoloy long life 3 kW immersion heater
Spare part no: 8-716-121-849



High limit thermostat (Solar and heat pump models)
Spare part no: 8-716-121-851

* Refer to Heat Pump manufacturer's installation instructions for your model and system configuration.

GREENSTAR GAS-FIRED SYSTEM BOILERS USING AN OPTIONAL INTERNAL DIVERTER VALVE

DESIGN AND SPECIFICATION CONSIDERATIONS WHEN USING THE OPTIONAL INTEGRAL DIVERTER VALVE

APPROACH:

When designing a heating system incorporating a Greenstar system boiler, the following needs to be taken into consideration:

- If you are going to use integral boiler controls then you will need to specify the Integral Diverter Valve Kit every time.
- If you wish to use the Integral Diverter Valve Kit then you can only use the integral boiler controls.
- Ensure it is possible to fit the domestic hot water (NTC) sensor into a suitable pocket in the cylinder.
- Ensure you have made yourself familiar with the wiring and pipe work required prior to quoting.

The following information will assist you in selecting the most appropriate option.

WHY USE THE INTEGRAL DIVERTER VALVE?

- The Integral Diverter Valve Kit can replace the more common Y-plan and S-plan type systems. Multi-zone systems can still be accommodated by using a 2 port motorized valve for each central heating zone in addition to the integral diverter valve kit. The integral diverter valve kit should still be used as this controls the primary flow to either the central heating or domestic hot water cylinder coil circuits.

Consideration must be given when quoting to ensure the additional cylinder flow & return pipework that must be connected directly to the Greenstar system boiler's pre-plumbing manifold is provided for.

Compatible Control	Greenstar gas-fired system boiler's optional Integral Diverter Valve Kit	Y-Plan or S-Plan Diverter Valve installation
External proprietary 230v manufacturer's controls pack	✗	✓
Comfort+ twin-channel programmer & proprietary room thermostat	✓	✗
Comfort + twin-channel programmer & Sense I intelligent room thermostat	✓	✗
Comfort+ I RF facia programmer and RF thermostat	✓	✗
Comfort + II RF twin-channel programmable RF thermostat	✓	✗
Bosch EasyControl smart thermostat	✓	✗
Sense II weather compensation system controller	✓	✗

1. The Integral Diverter Valve Kit is supplied with a domestic hot water (NTC) sensor that must be used to monitor the domestic hot water cylinder's temperature.

This requires the placing of the 8mm diameter sensor into the pocket. This sensor replaces the traditional cylinder thermostat and must be connected to the Greenstar system boiler's printed circuit board. You must refer to the installation literature of the appropriate boiler and Integral Diverter Valve Kit for further guidance.

To avoid the risk of inductive electrical interference, 100mm clearance must be provided between the domestic hot water (NTC) sensor's cable and other cables conducting 230V or 400V

2. This wiring method does not require the installation of a two port motorised valve.

Providing the wiring diagram is followed correctly by a competent person, protection of the cylinder from excessive storage temperatures will be assured and will ensure compliance with Building Regulation Part G3. This is equal to the accepted common practice of a 2-port motorised valve installed in the primary flow pipe to the cylinder and wired to the dual-thermostat.

Note: the Green Storage WB Range Cylinder series of unvented stainless steel indirect and twin coil cylinders are suitable for this application.

3. The wiring of the dual-thermostat supplied with the cylinder will need amending as per the diagram.

High limit thermostat (85°C)

The high limit thermostat should be electrically separated from the control thermostat of the dual- thermostat and wired as shown to ensure that in the event of an overheat situation within the cylinder, the permanent live electrical supply to the boiler is interrupted ensuring a safe installation and compliance with Building Regulation Part G3. See wiring diagrams on page 13.

Provision of cabling within the property must be allowed for connecting the high limit thermostat to the permanent live supply of the Greenstar system boiler according to each individual installation's characteristics during planning and at the time of installation.

Control thermostat (45°-65°C)

The hot water thermostat of the cylinder dual- thermostat will become redundant as the domestic hot water temperature is monitored by the domestic hot water (NTC) sensor (see page 13) and set by the domestic hot water control functionality located within the facia of the Greenstar system boiler.

4. Further information on wiring of systems in conjunction with Worcester appliances is available in the Gas Boiler Wiring Guide (part number 6 720 649 965) available to download from www.worcester-bosch.co.uk.

WIRING DIAGRAMS (CONTINUED)

SOLAR AND HEAT PUMP HIGH LIMIT CONTROL

These schematic wiring diagrams depict an IMIT high limit control stat and the connections are numbered accordingly. Where an alternative is supplied, connect as per manufacturer's instructions.

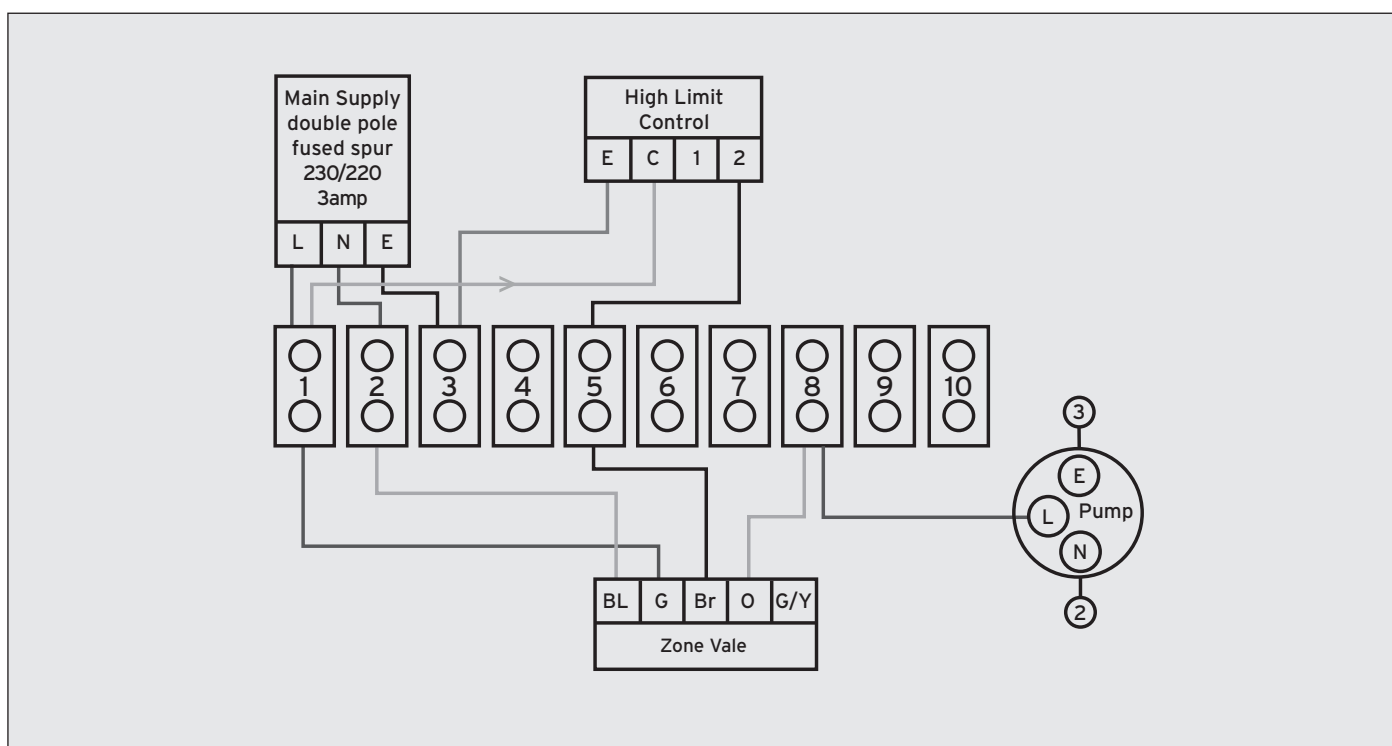
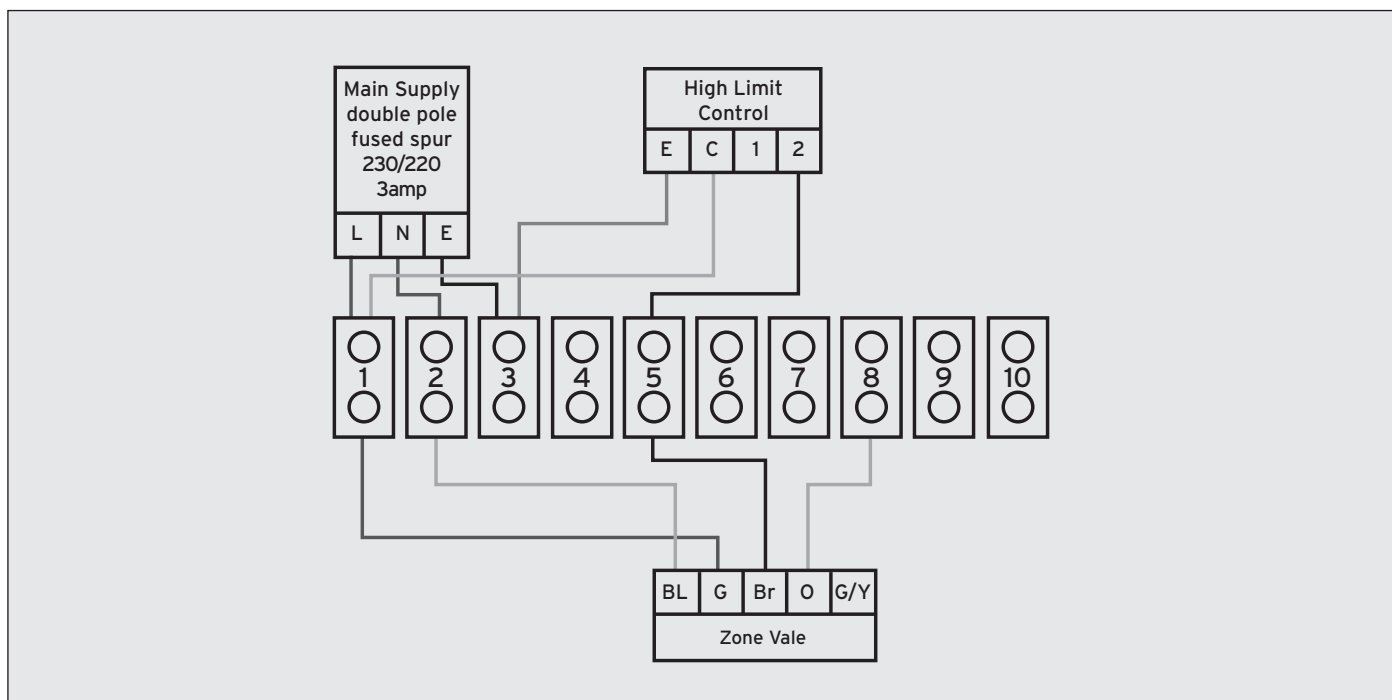

WIRING DIAGRAMS (CONTINUED)

BOSCH COMPRESS 7000 HEAT PUMP WIRING DIAGRAM (INCLUDING TW1 HOT WATER SENSOR)

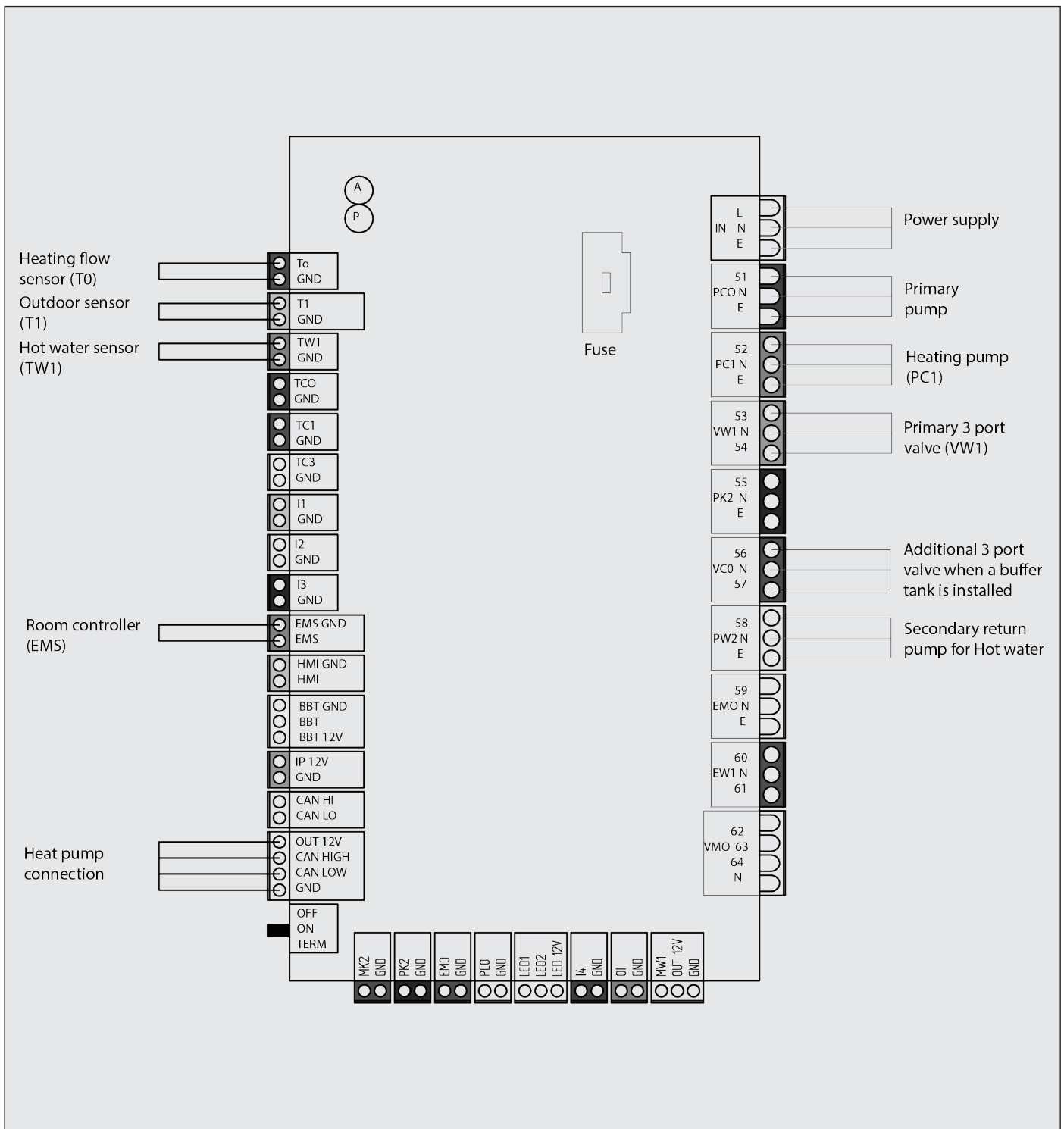

WIRING DIAGRAMS (CONTINUED)

VARIANT DUAL THERMOSTAT WIRING

The diagrams shown relate to the components listed. Other components and other manufacturers' components may vary in their wiring requirements, particularly thermostats. Always refer to manufacturers' instructions which may override the detail in order to function correctly.

NOTE: When using a Green Storage heat pump cylinder the high limit stat and hot water temperature sensor (TW1) should be used rather than the dual thermostat.

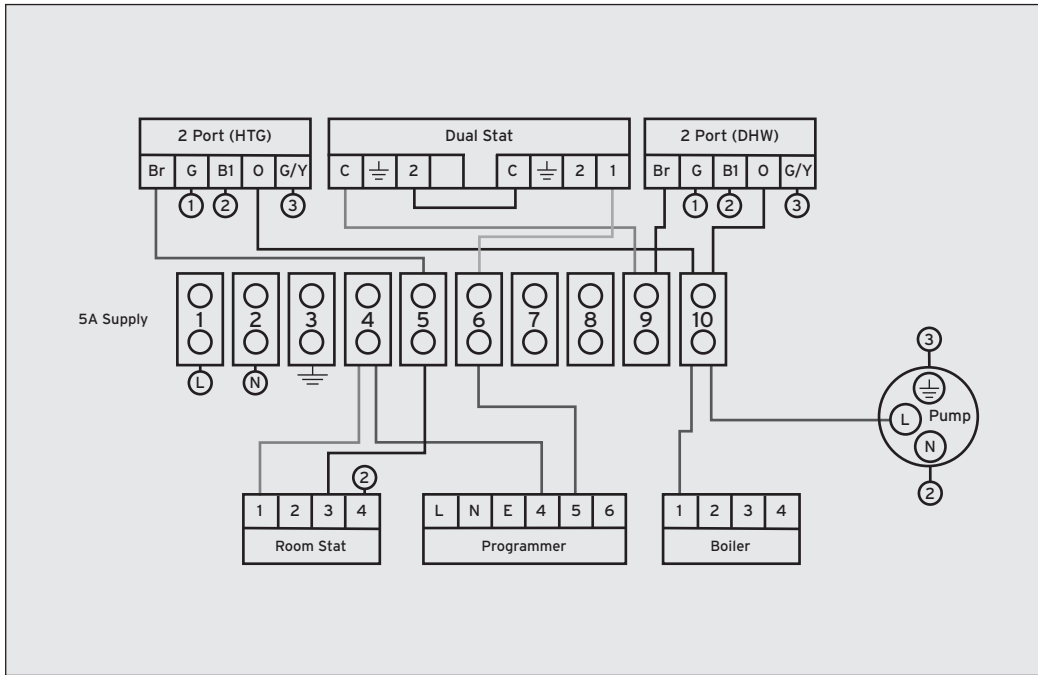

VARIANT DUAL THERMOSTAT WIRING
 Wiring Diagram 2 X Two Port Zone
 Valves (S-Plan)

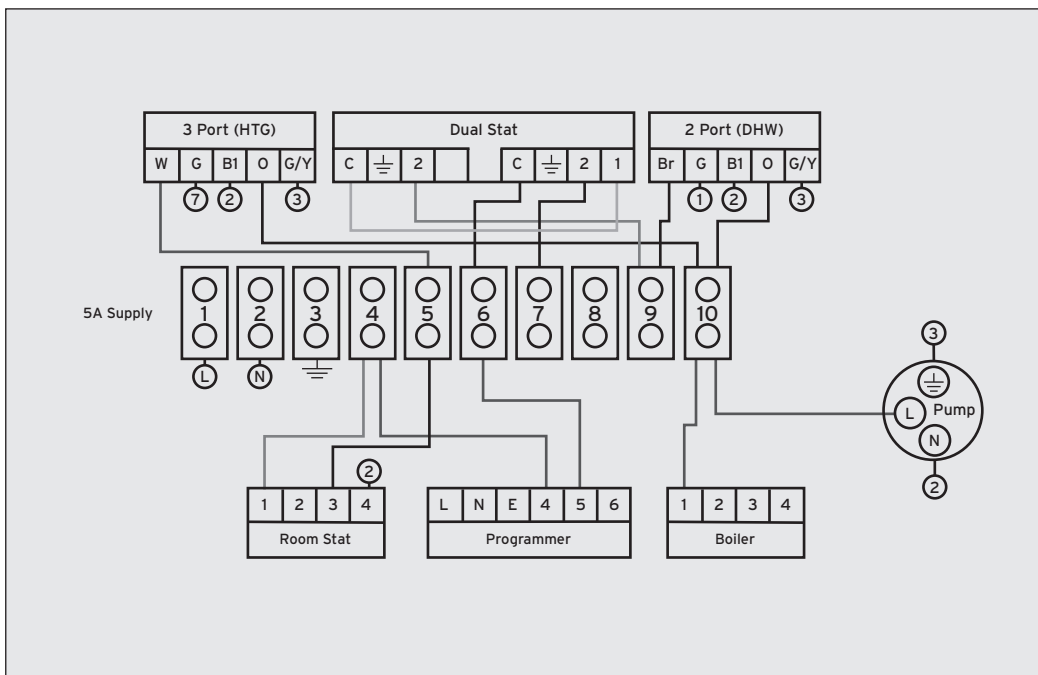

VARIANT DUAL THERMOSTAT WIRING
 Wiring Diagram 3 Port Mid Position
 (Y-Plan) + 2 Port Valve

WIRING DIAGRAMS (CONTINUED)

CONNECTED TO BOILER WITH PUMP OVER-RUN FACILITY

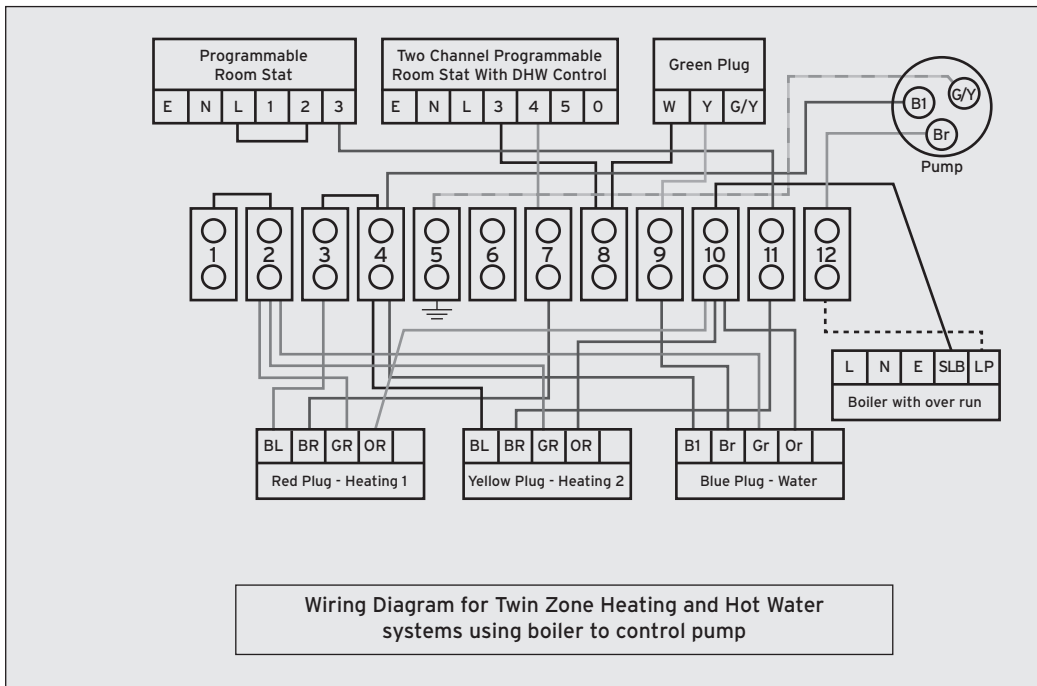

Table 5: Instruction for connection to a boiler with pump over-run facility.

1. Disconnect brown pre-wired pump flex from position 10
2. Reconnect brown pre-wired pump flex to position 12
3. Connect 5 core cables between boiler and wiring control centre to following positions:

Wiring Centre	Boiler	
Terminal 1	Permanent Live	L
Terminal 3	Permanent Neutral	N
Terminal 5	Permanent Earth	E
Terminal 10	Switched Live To Boiler	SL B
Terminal 12	Switched Live To Pump	L P

COMMISSIONING

STERILISATION

Only switch on power to the immersion heaters once sterilisation liquid has been purged and the cylinder filled with water.

FLUSHING & FILLING THE CYLINDER

Check that the pressure in the expansion vessel is 3 bar (45PSI), i.e. the same as the setting of the pressure reducing valve. The valve is of the car tyre (Schrader) type. Check all the connections for tightness including any factory made connections such as the immersion heater and the temperature and pressure relief valve. Before filling, open the hot tap furthest away from the unvented cylinder to let air out.

Open the cold main isolation valve and allow the unit to fill. When water flows from the tap allow it to run for a short while to flush through any dirt, swarf or flux residue. Close the tap and open every other hot tap in turn to purge all remaining air.

INDIRECT UNITS

Ensure the heating circuit has been fully flushed, carrying out commissioning in line with the boiler, heat pump or solar thermal manufacturer's commissioning instructions for the heating and the primary circuit. Primary pipework must be filled, vented and tested in accordance with the boiler manufacturer's instructions. To ensuring all pipework is fully vented, bleed valves may need opening, especially on any raised pipes; inadequate flushing or venting could cause damage to the circulation pump.

Ensure the lever on the two port valve is set to the filling position and fill the primary circuit; ensuring the appropriate inhibitors are added in the right concentrations. When full, move the lever back. Switch the programmer to Domestic Hot Water (DHW) and allow the unit to start to heat. Adjust the dial of the dual thermostat to between 55°C and 65°C as required. Allow unit to heat up, adjust the thermostat so that the heater switches off at 60°C. Record information on the Benchmark Commissioning Checklist (Page 21).

STORAGE TEMPERATURE

The recommended storage temperature setting for the cylinders is 60-65°C. In hard water areas consideration should be given to reducing this to 50-55°C. In many healthcare applications the guidance on Legionella control and safe water delivery temperatures will require storing the water at 60-65°C, distributing at 50-55°C and using thermostatic mixing valves to control the final temperature. For details consult the NHS Estates Guidance on safe hot water temperatures.

SAFETY CHECKS

During heat-up double check all pipework for leaks, ensuring all connections including the immersion heaters and any pre-plumbed connections are water tight. There should have been no sign of water coming from either the expansion relief valve or the temperature/pressure relief valve. Now hold both of these safety valves fully open, allowing as much water as possible to flow through the tundish. Check that your discharge pipework is free from debris and is carrying the water away to waste efficiently. It is normal that some water will splash out of the tundish. This should be minimised by ensuring the tundish, D1 and D2 pipes are vertical to allow clean flow. Release the valves and check that they reseat properly. On completion of commissioning, fill in the Benchmark Commissioning Checklist & leave with the homeowner.

BENCHMARK SCHEME

The installer must follow the Benchmark code of practice for the Benchmark certification to be valid. The Benchmark code of practice can be found online via www.centralheating.co.uk

DECOMMISSIONING & DISPOSAL

Damage to the environment and risks to personal health are avoided by the proper decommissioning and disposal of this product.

To decommission your unvented hot water cylinder, isolate the electricity supply to the immersion heater and boiler, heat pump or solar system, before draining the cylinder and safely disconnecting all fixtures and fittings.

The cylinder is made from many recyclable materials; therefore we strongly encourage recycling of this product at your Local Authority recycling centre at the end of its working life. For more information on proper disposal, please contact your local council or waste disposal office.

SERVICING

GENERAL

Servicing should only be carried out by competent installers and only spare parts approved by the manufacturer may be used. Never bypass any of the safety devices and never operate the unit without all of the safety devices being in place and fully operational.

DRAINING

Isolate from the electrical supply to prevent the immersion heaters burning out. Turn off the boiler. Isolate the unit from the cold mains. Attach a hose to the draining tap ensuring that it reaches to a level below the unit (this will ensure an efficient syphon is set up and the maximum amount of water is drained from the unit). First open the hot tap closest to the unit and then open the draining tap.

Warning: water drained off may be very hot!

Important: After draining the cylinder do not close the hot tap until the cylinder has fully cooled, failure to follow this instruction may result in damage to the cylinder and will invalidate the guarantee.

ANNUAL MAINTENANCE

The unvented cylinder requires an annual service in order to ensure safe working and optimum performance and to maintain the guarantee. It is essential that the following checks are performed by a competent installer on an annual basis. Commonly this is done at the same time as the annual boiler service.

1) Twist the cap of the expansion relief valve on the inlet control set and allow water to flow for 5 seconds. Release and make sure it reseats correctly. Repeat with the temperature & pressure relief valve. In both cases check that the discharge pipework is carrying the water away adequately. If not, check for blockages etc. and clear.

Warning: the water discharged may be very hot!

2) Check that any immersion heaters fitted are working correctly and that they are controlling the water at a temperature between 55°C and 65°C.

3) Check the pressure in the expansion vessel is charged to 3 bar. Turn off the water supply to the unit and open a hot tap first. The air valve on expansion vessel is a Schrader (car tyre) type. Air, nitrogen or CO₂ may be used to charge the expansion vessel.

4) Unscrew the head on the inlet control set and clean the mesh filter within (some water may escape).

5) The Service Record on page 22 of this manual must be updated at each service.

Your guarantee may be void without proof of annual servicing.

Table 6: Fault finding

Fault	Possible Cause	Solution
Water escaping from the case	Compression fitting on hot draw-off not sealing Leaking cylinder	Check/remake joint with sealing paste Isolate supply and contact us
Cold water at hot taps	Indirect - boiler not working Indirect - heat pump not working Indirect - motorised valve fault Indirect - cut-out in dual stat has operated	Check boiler - consult boiler manufacturer's instructions Check heat source - consult heat pump manufacturer's instructions Check plumbing / wiring to motorised valve Reset and investigate cause
Water discharges from expansion relief valve	If continual - pressure reducing valve (part of inlet control set) may not be operating correctly If continual - expansion relief valve seat may be damaged If intermittent - expansion vessel charge may have reduced / bladder perished Unit is being back pressurised	Check outlet pressure from inlet control set is 3 bar Remove cartridge - check seat and renew if necessary Check pressure in expansion vessel. Recharge to 3 bar if necessary. If bladder perished replace vessel With cylinder cold check pressure in cylinder. If this is the same as the incoming mains pressure then you are getting backfeed. Install a balanced cold supply (see page 5)
Water discharges from temperature & pressure relief valve	Unit has overheated - thermal controls have failed	Switch off power to boiler and immersion heaters. Leave water supply on. Wait until discharge stops. Isolate water supply and replace if faulty
Milky / cloudy water	Oxygenated water	Water from any pressurised system will release oxygen bubbles when flowing. The bubbles will settle out
No hot water flow	Cold mains off Strainer blocked in pressure reducing valve Inlet control set may be fitted incorrectly	Check and open stopcock Isolate water supply and clean Check and refit as required
Noise during hot water draw-off - typically worse in the morning	Loose pipework Water hammer	Install extra clips Fit a shock arrestor
Hot or warm water from cold tap	If tap runs cold after a minute or so the pipe is picking up heat from heating pipework	Insulate / re-route

INFORMATION FOR HOMEOWNERS

SPARE PARTS

See insert sheet for a list of part numbers.

USER INSTRUCTIONS

Your stainless system is automatic in normal use and requires only annual servicing, normally this is timed to coincide with the annual boiler, heat pump or solar thermal system service. You should employ a competent installer to perform the annual service and complete the benchmark log to maintain your 25-year guarantee on the inner vessel (10 years for heat pump models).

If water is flowing from the safety valves through the tundish, this indicates a fault in your heating system and action is needed.

If this water is hot, turn the boiler, immersion heater and/or heat pump/solar system off. Do not turn off the water until the discharge runs cool. The discharge may also stop.

Call out a competent installer to diagnose the fault.

Tell them you have a fault on your hot water system and that the system includes an unvented hot water cylinder.

AFTER DRAINING

Important: After draining the cylinder, the hot tap must be left fully open until the cylinder has fully cooled, failure to follow this instruction may result in damage to the cylinder & will invalidate the guarantee.

The installer must follow the Benchmark code of practice for the Benchmark certification to be valid. Please see page 2 and the Guarantee terms and conditions on pages 23 for further details.

SPECIFICATION - CYLINDER DETAILS & PERFORMANCE

Please refer to the insert sheet that came with this installation manual.

BENCHMARK SCHEME

The installer must follow the Benchmark code of practice for the Benchmark certification and your 25-year guarantee (10 years on heat pump models) to be valid. The Benchmark code of practice can be found online via www.centralheating.co.uk.

Worcester Bosch is a licensed member of the Benchmark Scheme which aims to improve the standards of installation and commissioning of domestic heating and hot water systems in the UK and to encourage regular servicing to optimise safety, efficiency and performance.

Benchmark is managed and promoted by the Heating and Hotwater Industry Council. For more information visit www.centralheating.co.uk

Important: Please ensure that the installer has fully completed the Benchmark Commissioning Checklist on page 21 of the installation instructions supplied with the product and that you have signed it to say that you have received a full and clear explanation of its operation.

The installer is legally required to complete this Benchmark Commissioning Checklist as a means of complying with the appropriate Building Regulations.

All installations must be notified to Local Area Building Control either directly or through a Competent Persons Scheme. A Building Regulations Compliance Certificate will then be issued to the customer who should, on receipt, write the Notification Number on the Benchmark Commissioning Checklist. This product should be serviced regularly to optimise its safety, efficiency and performance. The service engineer should complete the relevant Service Record Commissioning after each service. The Benchmark Commissioning Checklist and Service Record will be required in the event of any guarantee claim.

SERVICE RECORD

It is recommended that your hot water system is serviced regularly and that the appropriate Service Record is completed.

Service Provider

Before completing the appropriate Service Record below, please ensure you have carried out the service as described in the manufacturer's instructions.

SERVICE 1 Date

Engineer Name _____

Company Name _____

Telephone Number _____

Comments _____

Signature _____

SERVICE 2 Date

Engineer Name _____

Company Name _____

Telephone Number _____

Comments _____

Signature _____

SERVICE 3 Date

Engineer Name _____

Company Name _____

Telephone Number _____

Comments _____

Signature _____

SERVICE 4 Date

Engineer Name _____

Company Name _____

Telephone Number _____

Comments _____

Signature _____

SERVICE 5 Date

Engineer Name _____

Company Name _____

Telephone Number _____

Comments _____

Signature _____

SERVICE 6 Date

Engineer Name _____

Company Name _____

Telephone Number _____

Comments _____

Signature _____

SERVICE 7 Date

Engineer Name _____

Company Name _____

Telephone Number _____

Comments _____

Signature _____

SERVICE 8 Date

Engineer Name _____

Company Name _____

Telephone Number _____

Comments _____

Signature _____

SERVICE 9 Date

Engineer Name _____

Company Name _____

Telephone Number _____

Comments _____

Signature _____

SERVICE 10 Date

Engineer Name _____

Company Name _____

Telephone Number _____

Comments _____

Signature _____

GUARANTEE - TERMS & CONDITIONS

This guarantee applies only to products & parts supplied by Kingspan, the unvented cylinder manufacturer and its associated brands. Kingspan guarantees to the homeowner that for a period of five years from the date of commissioning, that the products and associated components installed will be free from defects in materials and workmanship, subject to the conditions set out below.

Note: this guarantee excludes all pipework and connections and excludes any ancillary equipment that may be connected to the product (e.g. descaling equipment, water softeners).

The guarantee is extended to a total of 25 years (10 years for heat pump models) for the stainless steel inner vessel in domestic properties and 5 years for parts supplied with the cylinder.

This guarantee means that the manufacturer will take responsibility for the cost of guarantee repair of a product by a Service Engineer approved by the manufacturer, so that the product shall conform to the manufacturers specification.

The manufacturer reserves the right, at its discretion, to replace a product or major component where it considers it to be beyond economical repair.

In the event of a breakdown during the guarantee period contact our customer service department. Guarantee repair is free of charge to you for any parts and labour, providing all the guarantee conditions have been met. Please read the following conditions before registering your product and before seeking any guarantee service support.

Important: You must complete register your cylinder at <https://www.worcester-bosch.co.uk/support/guarantees>

The product must be maintained by a competent person* within 12 months after commissioning, and thereafter at 12-monthly intervals. As the manufacturer, we reserve the right to seek evidence of this maintenance to our reasonable satisfaction, before approving any guarantee servicing / repairs. This may include evidence of completed Service Record and service agreement / invoice.

** A competent person is defined as a person representing a business, who has been adjudged by an accredited body (an example of which is BPEC) to be sufficiently competent to self-certify that its work complies with Document (G) Part 3 of the Building Regulations of England and Wales. May include SEI registered installers and/or FAS trained plumbers who have completed the renewables technology module.*

Any exchanged component will become the legal property of the manufacturer. This guarantee is valid provided that:

- The product has been installed by a competent installer and as per the instructions contained in the installation manual and all relevant Codes of Practice and

Regulations in force at the time of installation.

- Any disinfection has been carried out in accordance with BS EN 806:4.
- The product has not been modified in any way.
- The system is fed from domestic mains water supply compliant with Water Regulations 2000.
- The product has only been used for the storage of wholesome water (max. 250mg/l chloride); for hard water areas, the use of an electrolytic scale reducer is recommended.
- Any 3rd party labour charges associated with replacing the unit or any of its components have been authorised in advance by the Customer Service/ Technical Support team.
- It has only been used for the storage of potable water.
- The product has not been subjected to frost, nor has it been tampered with or been subjected to misuse or neglect.
- No factory fitted parts have been removed for unauthorised repair or replacement.
- The Benchmark™ Commissioning Checklist and Service Record included with this product installation manual have been completed.
- Regular maintenance has been carried out by a competent person in accordance with the requirements set out in the maintenance section of the installation manual.
- The owner or installer has registered the product within 30 days of commissioning/occupation (in new build). Failure to do so may result in a reduced guarantee period.
- Evidence of purchase and date of supply must be submitted upon making a claim.
- Only replacement parts authorised by the manufacturer have been used.
- If a defect arises and a valid claim is received within the guarantee period, at its option and to the extent permitted by law the manufacturer shall either:

- 1) Repair the defect at no charge, using new or refurbished replacement parts or
- 2) Exchange the product with a product that is new or which has been manufactured using new or serviceable used parts or
- 3) Refund the purchase price or a reasonable proportion of the purchase price. The manufacturer reserves the right to inspect the product at your home before proceeding with any guarantee repair or replacement.

Any valid guarantee claims or guarantee service does not extend the original guarantee period. Information on extended guarantee is available upon request.

The guarantee only applies to the property at which the product was originally installed and applies only to properties in the United Kingdom and Ireland. The guarantee is fully transferable from a change of legal ownership of the property.

Exclusions

The manufacturer will not be liable for any fault or costs arising from incorrect installation, incorrect application, lack of regular maintenance or neglect, accidental damage, malicious damage, misuse, any alteration, tampering or repair carried by a non-competent person.

The guarantee does not cover:

- The product, if the factory fitted temperature and pressure relief valve has been tampered with or removed.
- The effects of scale build up or the effects of corrosion.
- Any consequential losses caused by the failure or malfunction of the product.
- Faults and any associated costs arising from lack of power or water.
- Failure incurred by water contamination, air pollution and natural disasters.
- Installations outside the United Kingdom or Ireland.
- Any consequential loss, loss of profits, revenues or receipts howsoever arising from any non-conformity or defect affecting the product or from any delay in repair or replacement of the product.
- Any loss or damage caused by delay in conduct of services or supply of parts required to rectify the non-conformity or defect.
- Cost of repair or replacement of any product consumables or decorative finishes, such as filters and casings.

The manufacturer shall not be responsible for any consequential damage, howsoever caused.

This guarantee does not affect any legal rights you may have as a consumer under applicable national legislation governing your purchase of this product.

Manufactured by, Kingspan Water & Energy, Tadman Street, Wakefield, West Yorkshire, WF1 5QU, www.kingspan.com

The manufacturer shall make final determination as to the validity of any guarantee claim, and shall be entitled to charge you all reasonable costs incurred in investigating the claim where no fault is found, or the guarantee claim is rejected in accordance with these conditions.

Green Storage WB Range

Installation & Maintenance Instructions
